

1. A radioactive nuclei with decay constant $0.5/s$ is being produced at a constant rate of 100 nuclei/s. If at $t=0$ there were no nuclei, the time when there are 50 nuclei is :

- (1) $\ln\left(\frac{4}{3}\right)s$ (2) $\ln 2s$
 (3) $2\ln\left(\frac{4}{3}\right)s$ (4) $1s$

Ans. (3)

Sol. $\frac{dN}{dt} = 100 - 0.5N$

$$\int_0^{50} \frac{dN}{100 - 0.5N} = \int_0^t dt$$

$$-\frac{1}{0.5} [\ln(100 - 0.5N)]_0^{50} = t$$

$$\Rightarrow t = 2 \ln \left(\frac{100}{75} \right) = 2 \ln \left(\frac{4}{3} \right)$$

2. Match the List - I (Phenomenon associated with electromagnetic radiation) with List - II (Part of electromagnetic spectrum) and select the correct code from the choices given below the lists :

List-I		List-II	
I	Double of sodium	A	Visible radiation
II	Wavelength corresponding to temperature associated with the isotropic radiation filling all space	B	Microwave
III	Wavelength emitted by atomic hydrogen in intersellar space	C	Short radiowave
IV	Wavelength of radiation arising from two close energy levels in hydrogen	D	X-rays

- (1) (I)-(A), (II)-(B), (III)-(B), (IV)-(C)
 (2) (I)-(D), (II)-(C), (III)-(A), (IV)-(B)
 (3) (I)-(A), (II)-(B), (III)-(C), (IV)-(C)
 (4) (I)-(B), (II)-(A), (III)-(D), (IV)-(A)

Ans. (4)

3. A parallel plate capacitor is made of two plates of length l , width ω and separated by distance d . A dielectric slab (dielectric constant K) that fits exactly between the plates is held near the edge of the plates. It is pulled into the capacitor by a force $F = -\frac{\partial U}{\partial x}$ where U is the energy of the capacitor when dielectric is inside the capacitor up to distance x (See figure). If the charge on the capacitor is Q then the force on the dielectric when it is near the edge is

- (1) $\frac{Q^2 d}{2\omega l^2 \epsilon_0} K$
 (2) $\frac{Q^2 \omega}{2dl^2 \epsilon_0} (K - 1)$
 (3) $\frac{Q^2 d}{2\omega l^2 \epsilon_0} (K - 1)$
 (4) $\frac{Q^2 \omega}{2dl^2 \epsilon_0} K$

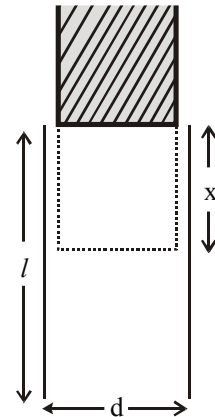

Ans. (3)

Sol. $C = C_1 + C_2$

$$= \frac{K(x\omega)\epsilon_0}{d} + \frac{(1-x)\omega\epsilon_0}{d}$$

$$C = \frac{\omega\epsilon_0}{d} [kx + (l - x)]$$

$$C = \frac{\omega\epsilon_0}{d} [l + (k - 1)x]$$

$$U = \frac{1}{2} \frac{Q^2}{C} = \frac{d.Q^2}{2\omega\epsilon_0[l + (k - 1)x]}$$

$$\frac{du}{dx} = -\frac{d.Q^2(K - 1)}{2\omega\epsilon_0[l + (K - 1)x]^2}$$

$$F = -\frac{du}{dx} = \frac{Q^2.d(K - 1)}{2\omega l^2 \epsilon_0} \text{ at } (x = 0)$$

4. A cone of base radius R and height h is located in a uniform electric field \vec{E} parallel to its base. The electric flux entering the cone is :-

- (1) $4EhR$ (2) $\frac{1}{2}EhR$
 (3) EhR (4) $2EhR$

Ans. (3)

Sol. flux $\phi = E \cdot A_{\perp}$

$$= E \cdot \left(\frac{1}{2}h \times 2R \right)$$

$$= Ehr$$

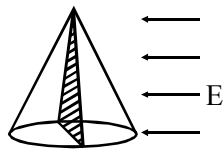

5. Three identical bars A, B and C are made of different magnetic materials. When kept in a uniform magnetic field, the field lines around them look as follows :

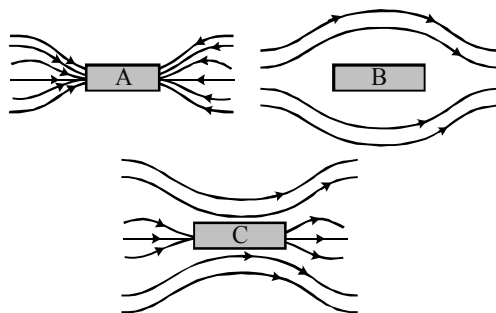

Make the correspondence of these bars with their material being diamagnetic (D) ferromagnetic (F) and paramagnetic (P)

- (1) $A \leftrightarrow P, B \leftrightarrow F, C \leftrightarrow D$
 (2) $A \leftrightarrow F, B \leftrightarrow P, C \leftrightarrow D$
 (3) $A \leftrightarrow D, B \leftrightarrow P, C \leftrightarrow F$
 (4) $A \leftrightarrow F, B \leftrightarrow D, C \leftrightarrow P$

Ans. (4)

Sol.

6. The average mass of rain drops is 3.0×10^{-5} kg and their average terminal velocity is 9 m/s. Calculate the energy transferred by rain to each square metre of the surface at a place which receives 100 cm of rain in a year.

- (1) 9.0×10^4 J (2) 4.05×10^4 J
 (3) 3.5×10^5 J (4) 3.0×10^5 J

Ans. (2)

Sol. $E = \frac{1}{2} (1 \times 10^3) \times 81$
 $= 500 \times 81$
 $= 40500$ J
 $= 4.05 \times 10^4$ J

7. An ideal monoatomic gas is confined in a cylinder by a spring loaded piston of cross section 8.0×10^{-3} m². Initially the gas is at 300K and occupies a volume of 2.4×10^{-3} m³ and the spring is in its relaxed state as shown in figure. The gas is heated by a small heater until the piston moves out slowly by 0.1 m. The force constant of the spring is 8000 N/m and the atmospheric pressure is 1.0×10^5 N/m². The cylinder and the piston are thermally insulated. The piston and the spring are massless and there is no friction between the piston and the cylinder. The final temperature of the gas will be : (Neglect the heat loss through the lead wires of the heater. The heat capacity of the heater coil is also negligible) :-

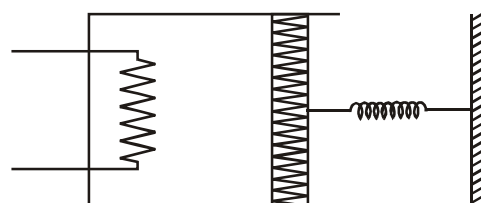

- (1) 500 K (2) 300 K
 (3) 800 K (4) 1000 K

Ans. (3)

Sol. $A = 8 \times 10^{-3}$ m²

$$T_1 = 300$$
 K

$$V_1 = 2.4 \times 10^{-3}$$
 m³

$$V_2 = V_1 + A\Delta x$$

$$= 2.4 \times 10^{-3} + 8 \times 10^{-3} \times 0.1$$

$$= 3.2 \times 10^{-3}$$
 m³

$$K = 8000$$
 N/m

$$T_2 = ?$$

$$P_1 = 10^5$$
 N/m²

$$P_2 = P_0 + \frac{kx}{A} = 10^5 + \frac{8000 \times 0.1}{8 \times 10^{-3}}$$

$$= 2 \times 10^5$$
 N/m²

$$\frac{P_1 V_1}{T_1} = \frac{P_2 V_2}{T_2}$$

$$\frac{10^5 \times 2.4 \times 10^{-3}}{300} = \frac{2 \times 10^5 \times 3.2 \times 10^{-3}}{T_2}$$

$$T_2 = \frac{3.2 \times 300}{1.2}$$

$$= 800$$
 K

8. The angular frequency of the damped oscillator is given by $\omega = \sqrt{\left(\frac{k}{m} - \frac{r^2}{4m^2}\right)}$ where k is the spring constant, m is the mass of the oscillator and r is the damping constant. If the ratio $\frac{r^2}{mk}$ is 8%, the change in time period compared to the undamped oscillator is approximately as follows :-

- (1) Decreases by 1% (2) Increases by 8%
 (3) Increases by 1% (4) Decreases by 8%

Ans. (3)

Sol. $\omega = \sqrt{\left(\frac{k}{m} - \frac{r^2}{4m^2}\right)}$

$$\omega_0 = \sqrt{\frac{k}{m}}$$

$$\omega_0 - \omega = \sqrt{\frac{k}{m}} - \sqrt{\frac{k}{m} - \frac{r^2}{4m^2}}$$

$$= \sqrt{\frac{k}{m}} \left(1 - \sqrt{1 - \frac{r^2}{4mk}}\right)$$

$$\frac{\omega_0 - \omega}{\omega_0} = \left[1 - \left(1 - \frac{r^2}{4mk}\right)^{1/2}\right]$$

$$= \left[1 - \left(1 - \frac{r^2}{8mk}\right)\right]$$

$$= \frac{r^2}{8mk} = 1\%$$

9. A coil of circular cross-section having 1000 turns and 4 cm² face area is placed with its axis parallel to a magnetic field which decreases by 10⁻² Wb m⁻² in 0.01 s. The e.m.f. induced in the coil is :

- (1) 200 mV (2) 0.4 mV
 (3) 4mV (4) 400 mV

Ans. (4)

Sol. $\varepsilon = - \frac{d\phi}{dt}$

$$\varepsilon = \frac{1000 \times 4 \times 10^{-4} \times 10^{-2}}{.01}$$

$$= 4 \times 10^{-1} \text{ V}$$

10. Three straight parallel current carrying conductors are shown in the figure. The force experienced by the middle conductor of length 25 cm is :

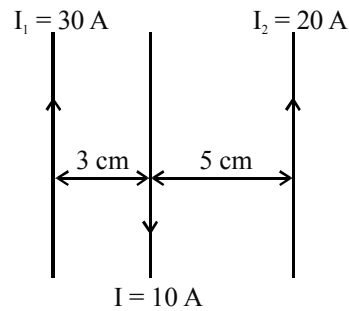

- (1) 9×10^{-4} toward left
 (2) Zero
 (3) 6×10^{-4} N toward left
 (4) 3×10^{-4} toward right

Ans. (4)

11. A body of mass 5 kg under the action of constant force $\vec{F} = F_x \hat{i} + F_y \hat{j}$ has velocity at

t = 0 s as $\vec{v} = (6\hat{i} - 2\hat{j})$ m/s and at t = 10 s as

$\vec{v} = +6\hat{j}$ m/s. The force \vec{F} is :-

- (1) $\left(\frac{3}{5}\hat{i} - \frac{4}{5}\hat{j}\right)$ N (2) $(-3\hat{i} + 4\hat{j})$ N
 (3) $(3\hat{i} - 4\hat{j})$ N (4) $\left(-\frac{3}{5}\hat{i} + \frac{4}{5}\hat{j}\right)$ N

Ans. (2)

Sol. $F = \frac{m(v_f - v_i)}{t}$

$$= \frac{5(6\hat{j} - 6\hat{i} + 2\hat{j})}{10} = \frac{40\hat{j} - 30\hat{i}}{10} = -3\hat{i} + 4\hat{j}$$

12. In the circuit diagrams (A, B, C and D) shown below, R is a high resistance and S is a resistance the order of galvanometer G. The correct circuit, corresponding to the half deflection method for finding the resistance and figure of merit of the galvanometer, is the circuit labelled as :-

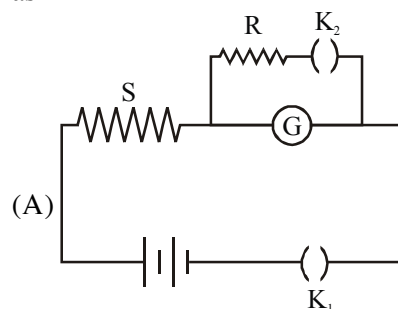

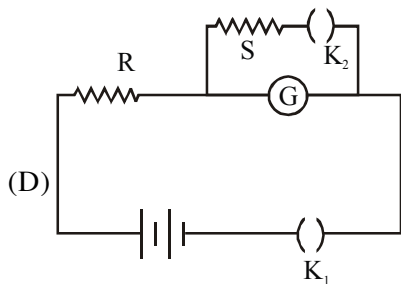
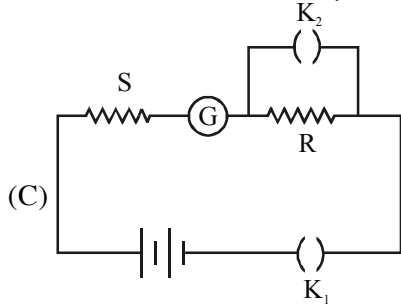
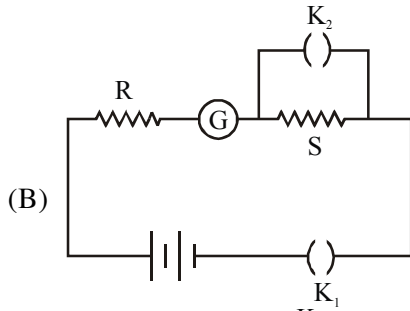

- (1) Circuit C with $G = S$
 (2) Circuit B with $G = S$
 (3) Circuit A with $G = \frac{RS}{(R - S)}$
 (4) Circuit D with $G = \frac{RS}{R - S}$

Ans. (4)

13. A tank with a small hole at the bottom has been filled with water and kerosene (specific gravity 0.8). The height of water is 3 m and that of kerosene 2 m. When the hole is opened the velocity of fluid coming out from it is nearly :

- (take $g = 10 \text{ ms}^{-2}$ and density of water = 10^3 kg m^{-3})
 (1) 7.6 ms^{-1} (2) 9.6 ms^{-1}
 (3) 10.7 ms^{-1} (4) 8.5 ms^{-1}

Ans. (2)

Sol. $1000 \times 10 \times 3 + 800 \times 10 \times 2 = \frac{1}{2} \times 1000 v^2$

$$v = \sqrt{92}$$

$$= 9.6 \text{ m/s}$$

14. A photon of wavelength λ is scattered from an electron, which was at rest. The wavelength shift $\Delta\lambda$ is three times of λ and the angle of scattering θ is 60° . The angle at which the electron recoiled is ϕ . The value of $\tan \phi$ is : (electron speed is much smaller than the speed of light)

- (1) 0.28 (2) 0.22 (3) 0.25 (4) 0.16

Ans. (3)

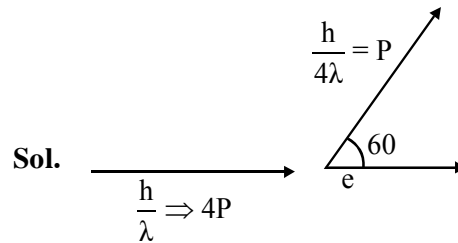

$$\Delta P = (P \cos 60 \hat{i} + P \sin 60 \hat{j}) - 4P \hat{i}$$

$$= -\frac{7P}{2} \hat{i} + \frac{\sqrt{3}P}{2} \hat{j} \Rightarrow \tan \phi = \frac{\sqrt{3}}{7}, \tan \phi = 0.25$$

15. The Bulk moduli of Ethanol, Mercury and Water are given as 0.9, 25 and 2.2 respectively in units of 10^9 Nm^{-2} . For a given value of pressure, the fractional compression in volume

is $\frac{\Delta V}{V}$. Which of the following statements

about $\frac{\Delta V}{V}$ for these three liquids is correct? :-

- (1) Water > Ethanol > Mercury
 (2) Ethanol > Mercury > Water
 (3) Ethanol > Water > Mercury
 (4) Mercury > Ethanol > Water

Ans. (3)

16. A hot body, obeying Newton's law of cooling is cooling down from its peak value 80°C to an ambient temperature of 30°C . It takes 5 minutes in cooling down from 80°C to 40°C . How much time will it take to cool down from 62°C to 32°C ? (Given $\ln 2 = 0.693$, $\ln 5 = 1.609$)

- (1) 9.6 minutes (2) 6.5 minutes
 (3) 8.6 minutes (4) 3.75 minutes

Ans. (2)

Sol. $\frac{d\theta}{dt} = -C(\theta - \theta_0)$

$$\int_{80}^{40} \frac{1}{\theta - \theta_0} d\theta = -C/5$$

$$\int_{62}^{32} \frac{1}{\theta - \theta_0} d\theta = -Ct$$

$$\ln\left(\frac{80-30}{40-30}\right) = 5C$$

$$\ln\left(\frac{62-30}{40-50}\right) = Ct$$

$$\ln 5 = 5c = 1.609$$

$$\ln 16 = ct = 4 \times 0.693$$

$$t = 8.6 \text{ min}$$

- 17.** A Zener diode is connected to a battery and a load as shown below :-
The currents I , I_Z and I_L are respectively.

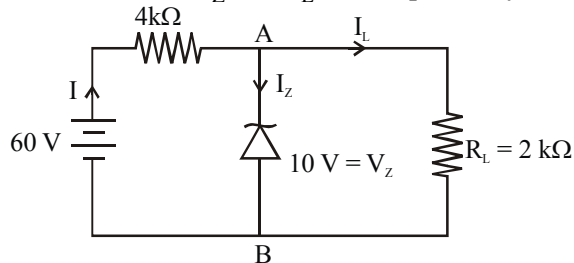

- (1) 12.5 mA, 5 mA, 7.5 mA
 (2) 15 mA, 7.5 mA, 7.5 mA
 (3) 12.5 mA, 7.5 mA, 5 mA
 (4) 15 mA, 5 mA, 10 mA

Ans. (3)

Sol. $I_L = \frac{10V}{2k\Omega} = 5mA$

$$I = \frac{(60-10)v}{4k\Omega} = \frac{50}{4k\Omega} = 12.5 \text{ mA}$$

$$I_Z = I - I_L = (12.5 - 5) \text{ mA} = 7.5 \text{ mA}$$

- 18.** An air bubble of radius 0.1 cm is in a liquid having surface tension 0.06 N/m and density 10^3 kg/m^3 . The pressure inside the bubble is 1100 Nm^{-2} greater than the atmospheric pressure. At what depth is the bubble below the surface of the liquid? ($g = 9.8 \text{ ms}^{-2}$) :-

- (1) 0.1 m (2) 0.20 m
 (3) 0.15 m (4) 0.25 m

Ans. (1)

Sol. $h \text{ dg} + \frac{LT}{r} = 1100$

$$h \times 10^3 \times 4.8 = 1100 - \frac{2 \times 0.06}{0.1 \times 10^{-2}}$$

$$= 980$$

$$h = \frac{980}{9.8 \times 10^3} = 0.1 \text{ m}$$

- 19.** In the circuit shown, current (in A) through the 50 V and 30 V batteries are, respectively :-

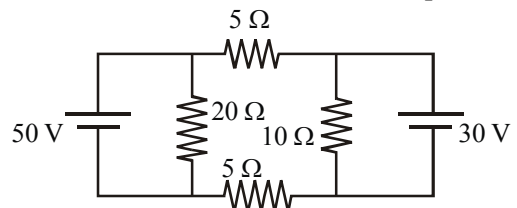

- (1) 3 and 2.5 (2) 3.5 and 2
 (3) 4.5 and 1 (4) 2.5 and 3

Ans. (3)

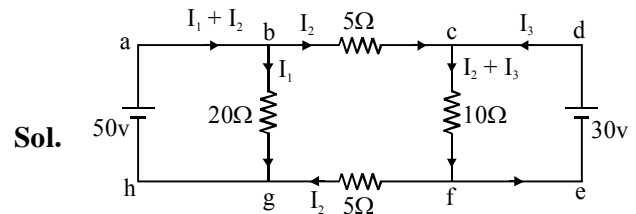

Sol.

KVL in loop abgha

$$20 I_1 = 50$$

$$I_1 = 2.5 \text{ A}$$

KVL in loop abcdefgha

$$50 - 5I_2 - 30 - 5I_2 = 0$$

$$I_2 = 2 \text{ A}$$

KVL in loop cdefc

$$30 = 10(I_2 + I_3)$$

$$\Rightarrow I_2 + I_3 = 3$$

$$I_3 = 3 - 2$$

$$= 1 \text{ A}$$

$$\therefore \text{Current through 50 V battery is} = I_1 + I_2 = 2.5 + 2.0 = 4.5 \text{ A}$$

$$\text{current through 30V battery} = I_3 = 1 \text{ A}$$

20. During an adiabatic compression, 830 J of work is done on 2 moles of a diatomic ideal gas to reduce its volume by 50%. The change in its temperature is nearly : ($R = 8.3 \text{ JK}^{-1}\text{mol}^{-1}$)
 (1) 40 K (2) 20 K (3) 33 K (4) 14 K

Ans. (2)

21. A small ball of mass m starts at a point A with speed v_0 and moves along a frictionless track AB as shown. The track BC has coefficient of friction μ . The ball comes to stop at C after travelling a distance L which is :

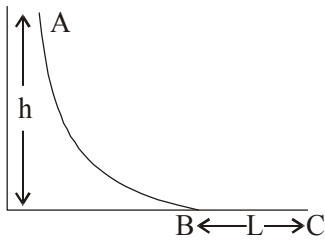

- (1) $\frac{h}{2\mu} + \frac{v_0^2}{2\mu g}$ (2) $\frac{2h}{\mu} + \frac{v_0^2}{2\mu g}$
 (3) $\frac{h}{\mu} + \frac{v_0^2}{2\mu g}$ (4) $\frac{h}{2\mu} + \frac{v_0^2}{\mu g}$

Ans. (3)

Sol. $mgh - \mu mgL = 0 - \frac{1}{2}mv_0^2$

$$\mu mgL = mgh + \frac{1}{2}mv_0^2$$

$$L = \frac{h}{\mu} + \frac{v_0^2}{2\mu g}$$

22. In a compound microscope the focal length of objective lens is 1.2 cm and focal length of eye piece is 3.0 cm. When object is kept at 1.25 cm in front of objective, final image is formed at infinity. Magnifying power of the compound microscope should be :

- (1) 400 (2) 200 (3) 100 (4) 150

Ans. (2)

Sol. $mp = \frac{f_o}{f_o + 40} \left(\frac{D}{f_e} \right)$
 $= \frac{1.2}{1.2 + (-1.25)} \left(\frac{25}{3} \right)$
 $= 200$

23. A thin bar of length L has a mass per unit length λ , that increases linearly with distance from one end. If its total mass is M and its mass per unit length at the lighter end is λ_0 , then the distance of the centre of mass from the lighter end is :

(1) $\frac{2L}{3} - \frac{\lambda_0 L^2}{6M}$

(2) $\frac{L}{2} - \frac{\lambda_0 L^2}{4M}$

(3) $\frac{L}{3} + \frac{\lambda_0 L^2}{4M}$

(4) $\frac{L}{3} + \frac{\lambda_0 L^2}{8M}$

Ans. (1)

Sol. Mass per unit length = $\lambda_0 + kx$

$$M = \int_0^L (\lambda_0 + kx) dx$$

$$M = \lambda_0 L + \frac{K \times L^2}{2}$$

$$\frac{2M - \lambda_0 L}{L^2} = K$$

$$\frac{2M}{L^2} - \frac{\lambda_0}{L} = K$$

$$\frac{\int dm(r)}{\int dm} = \frac{\int (\lambda dx) x}{M} = \frac{\int_0^L (\lambda_0 x + kx^2) dx}{M}$$

$$r_{cm} = \frac{\lambda_0 L + \frac{kL^2}{2}}{M}$$

substitute 'k'

$$r_{cm} = \frac{2L}{3} - \frac{\lambda_0 L^2}{6M}$$

24. In terms of resistance R and time T, the dimensions of ratio $\frac{\mu}{\epsilon}$ of the permeability μ and permittivity ϵ is :-

- (1) $[R^2]$ (2) $[R^2T^2]$
 (3) $[RT^{-2}]$ (4) $[R^2T^{-1}]$

Ans. (1)

25. The initial speed of a bullet fired from a rifle is 630 m/s. The rifle is fired at the centre of a target 700 m away at the same level as the target. How far above the centre of the target the rifle must be aimed in order to hit the target
 (1) 4.2 m (2) 6.1 m (3) 1.0 m (4) 9.8 m

Ans. (2)

26. An object is located in a fixed position in front of a screen. Sharp image is obtained on the screen for two positions of a thin lens separated by 10 cm. The size of the images in two situations are in the ratio 3 : 2. What is the distance between the screen and the object ?

- (1) 99.0 cm
 (2) 124.5 cm
 (3) 144.5 cm
 (4) 65.0 cm

Ans. (1)

Sol. $\frac{m_1}{m_2} = \frac{3}{2} = \left(\frac{D+10}{D-10}\right)^2$

$D = 99 \text{ cm}$

27. Two monochromatic light beams of intensity 16 and 9 units are interfering. The ratio of intensities of bright and dark parts of the resultant pattern is :

- (1) $\frac{4}{3}$ (2) $\frac{49}{1}$ (3) $\frac{16}{9}$ (4) $\frac{7}{1}$

Ans. (2)

Sol. $\frac{I_{\max}}{I_{\min}} = \frac{(\sqrt{16} + \sqrt{9})^2}{(\sqrt{16} - \sqrt{9})^2} = \frac{49}{1}$

28. From a sphere of mass M and radius R, a smaller sphere of radius $\frac{R}{2}$ is carved out such that the cavity made in the original sphere is between its centre and the periphery. (See figure). For the configuration in the figure where the distance between the centre of the original sphere and the removed sphere is 3R, the gravitational force between the two spheres is :

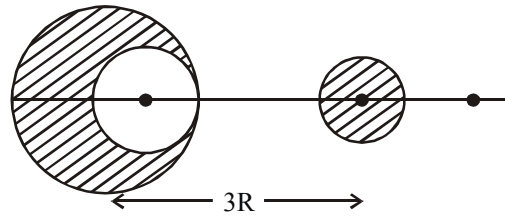

- (1) $\frac{59 GM^2}{450 R^2}$ (2) $\frac{GM^2}{225 R^2}$
 (3) $\frac{41GM^2}{450 R^2}$ (4) $\frac{41GM^2}{3600 R^2}$

Ans. (4)

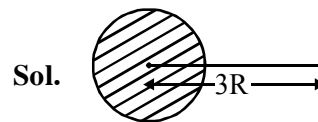

Field at 3R is $\frac{GM}{9R^2}$ at P

Due to cavity field at P is $\frac{GM}{8(2.5R)^2} = \frac{GM}{50R^2}$

29. An electromagnetic wave of frequency 1×10^{14} hertz is propagating along z-axis. The amplitude of electric field is 4 V/m. If $\epsilon_0 = 8.8 \times 10^{-12} \text{ C}^2/\text{N}\cdot\text{m}^2$, then average energy density of electric field will be :

- (1) $35.2 \times 10^{-12} \text{ J/m}^3$ (2) $35.2 \times 10^{-13} \text{ J/m}^3$
 (3) $35.2 \times 10^{-11} \text{ J/m}^3$ (4) $35.2 \times 10^{-10} \text{ J/m}^3$

Ans. (1)

30. Two factories are sounding their sirens at 800 Hz. A man goes from one factory to other at a speed of 2 m/s. The velocity of sound is 320 m/s. The number of beats heard by the person in one second will be :

- (1) 8 (2) 4 (3) 10 (4) 2

Ans. (3)

PART B – CHEMISTRY

1. The appearance of colour in solid alkali metal halides is generally due to :
- (1) Frenkel defect
 - (2) F-centres
 - (3) Schottky defect
 - (4) Interstitial position

Ans. (2)

2. Complete reduction of benzene-diazonium chloride with Zn/HCl gives :

- (1) Aniline
- (2) Phenylhydrazine
- (3) Hydrazobenzene
- (4) Azobenzene

Ans. (2)

3. Which of the following statements about Na_2O_2 is **not** correct ?

- (1) Na_2O_2 oxidises Cr^{3+} to CrO_4^{2-} in acid medium
- (2) It is diamagnetic in nature
- (3) It is the super oxide of sodium
- (4) It is a derivative of H_2O_2

Ans. (3)

- Sol.** Na_2O_2 is a peroxide O_2^{2-} which is occupied all paired electrons with π^*2p_x & π^*2p_y .

4. In allene (C_3H_4), the type(s) of hybridization of the carbon atoms is (are):

- (1) only sp^2
- (2) sp^2 and sp
- (3) sp and sp^3
- (4) sp^2 and sp^3

Ans. (2)

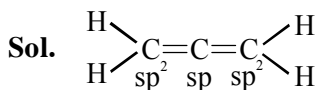

5. In the reaction of formation of sulphur trioxide by contact process $2\text{SO}_2 + \text{O}_2 \rightleftharpoons 2\text{SO}_3$ the rate of reaction was measured as

$$\frac{d[\text{O}_2]}{dt} = -2.5 \times 10^{-4} \text{ mol L}^{-1} \text{ s}^{-1}.$$

The rate of reaction in terms of $[\text{SO}_2]$ in $\text{mol L}^{-1}\text{s}^{-1}$ will be

- (1) -2.50×10^{-4}
- (2) -5.00×10^{-4}
- (3) -1.25×10^{-4}
- (4) -3.75×10^{-4}

Ans. (2)

Sol.

$$-\frac{1}{2} \frac{d}{dt} [\text{SO}_2] = -\frac{d}{dt} [\text{O}_2]$$

$$\begin{aligned} \Rightarrow \frac{d}{dt} [\text{SO}_2] &= -2 \times 2.5 \times 10^{-4} \\ &= -5 \times 10^{-4} \end{aligned}$$

6. Based on the equation

$$\Delta E = -2.0 \times 10^{-18} \text{ J} \left(\frac{1}{n_2^2} - \frac{1}{n_1^2} \right)$$

the wavelength of the light that must be absorbed to excite hydrogen electron from level $n = 1$ to level $n = 2$ will be ($h = 6.625 \times 10^{-34} \text{ Js}$, $c = 3 \times 10^8 \text{ ms}^{-1}$)

- (1) $2.650 \times 10^{-7} \text{ m}$
- (2) $1.325 \times 10^{-7} \text{ m}$
- (3) $1.325 \times 10^{-10} \text{ m}$
- (4) $5.300 \times 10^{-10} \text{ m}$

Ans. (2)

Sol.

$$\frac{1}{\lambda} = \frac{2 \times 10^{-18}}{hc} \left[\frac{1}{(1)^2} - \frac{1}{(2)^2} \right]$$

$$\Rightarrow \frac{1}{\lambda} = \frac{2 \times 10^{-18}}{6.625 \times 10^{-34} \times 3 \times 10^8} \times \frac{3}{4}$$

$$\Rightarrow \lambda = \frac{2 \times 6.625 \times 10^{-34} \times 10^8}{10^{-18}}$$

$$= 13.25 \times 10^{-8}$$

$$= 1.325 \times 10^{-7} \text{ m}$$

7. Given :-

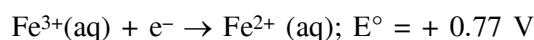

Considering the electrode potentials, which of the following represents the correct order of reducing power?

- (1) $\text{Al} < \text{Fe}^{2+} < \text{Br}^-$
- (2) $\text{Al} < \text{Br}^- < \text{Fe}^{2+}$
- (3) $\text{Fe}^{2+} < \text{Al} < \text{Br}^-$
- (4) $\text{Br}^- < \text{Fe}^{2+} < \text{Al}$

Ans. (4)

8. Consider the following equilibrium

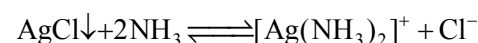

White precipitate of AgCl appears on adding which of the following?

- (1) NH_3
- (2) Aqueous NaCl
- (3) Aqueous NH_4Cl
- (4) Aqueous HNO_3

Ans. (2)

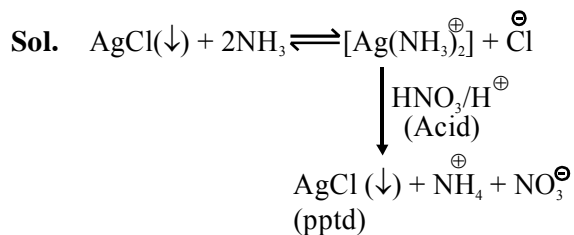

9. Tischenko reaction is a modification of

- (1) Cannizzaro reaction
- (2) Claisen condensation
- (3) Pinacol-pinacolone reaction
- (4) Aldol condensation

Ans. (1)

10. Which one of the following does **not** have a pyramidal shape ?

- (1) $\text{P}(\text{CH}_3)_3$
- (2) $(\text{SiH}_3)_3\text{N}$
- (3) $(\text{CH}_3)_3\text{N}$
- (4) $\text{P}(\text{SiH}_3)_3$

Ans. (2)

Sol. In $\text{N}(\text{SiH}_3)_3$ ℓp present on nitrogen atom of 2nd shall has greater donating tendency to vacant 3d-orbital of 'Si' but not this donating tendency to vacant 3d-orbital of 'Si' but not this donating tendency with P, due to 3rd pd element.

11. The following reaction

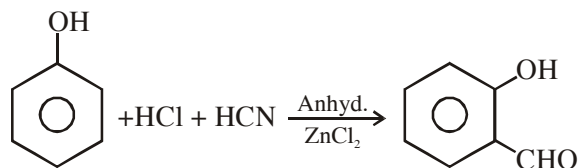

is known as

- (1) Perkin reaction
- (2) Kolbe's reaction
- (3) Gattermann reaction
- (4) Gattermann-Koch Formylation

Ans. (4)

Sol. In $(\text{SiH}_3)_3\text{N}$ N has strong back bonding tendency than other gsap.

12. Chlorobenzene reacts with trichloroacetaldehyde in the presence of H_2SO_4

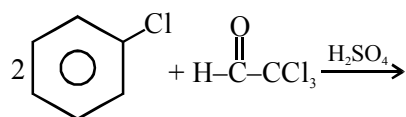

The major product formed is

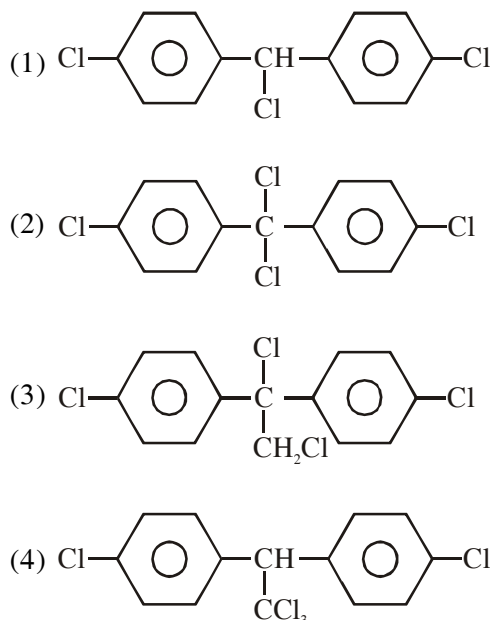

Ans. (4)

13. Shapes of certain interhalogen compounds are stated below. Which one of them is not correctly stated?

- (1) IF_7 : Pentagonal bipyramid
- (2) BrF_5 : Trigonal bipyramid
- (3) ICl_3 : Planar dimeric
- (4) BrF_3 : Planar T-shaped

Ans. (2)

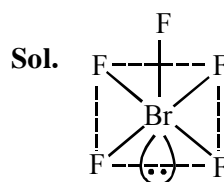

BrF_5 has square pyramidal shape (sp^3d^2) with one lone pair at below the basal plane.

14. Which one of the following statements is not correct?

- (1) Alcohols are weaker acids than water
- (2) The bond angle in methanol is 108.9°
- (3) Acid strength of alcohols decreases in the following order $\text{RCH}_2\text{OH} > \text{R}_2\text{CHOH} > \text{R}_3\text{COH}$
- (4) Carbon-oxygen bond length in methanol, CH_3OH is shorter than that of C-O bond length in phenol

Ans. (4)

15. Which of the following series correctly represents relations between the elements from X to Y?

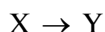

- (1) ${}_{18}\text{Ar} \rightarrow {}_{54}\text{Xe}$ Noble character increases
- (2) ${}_{3}\text{Li} \rightarrow {}_{19}\text{K}$ Ionization enthalpy increases
- (3) ${}_{6}\text{C} \rightarrow {}_{32}\text{Ge}$ Atomic radii increases
- (4) ${}_{9}\text{F} \rightarrow {}_{35}\text{Br}$ Electron gain enthalpy with negative sign increases

Ans. (3)

Sol. e^l on moving down the group shell number increases so its radii also increase from "C to Ge".

16. Which of the following statements about the depletion of ozone layer is correct?

- (1) The problem of ozone depletion is more serious at poles because ice crystals in the clouds over poles act as catalyst for photochemical reactions involving the decomposition of ozone by Cl^\bullet and ClO^\bullet radicals
- (2) The problem of ozone depletion is less serious at poles because NO_2 solidifies and is not available for consuming ClO^\bullet radicals
- (3) Oxides of nitrogen also do not react with ozone in stratosphere
- (4) Freons, chlorofluorocarbons, are inert chemically, they do not react with ozone in stratosphere

Ans. (1)

17. The initial volume of a gas cylinder is 750.0 mL. If the pressure of gas inside the cylinder changes from 840.0 mm Hg to 360.0 mm Hg, the final volume the gas will be

- (1) 1.750 L (2) 7.50 L
 (3) 3.60 L (4) 4.032 L

Ans. (1)

Sol. $P_1V_1 = P_2V_2$
 $\Rightarrow 840 \times 750 = 360 \times V_2$
 $\Rightarrow V_2 = \frac{840 \times 750}{360}$
 $= 1750 \text{ ml}$
 $= 1.75 \text{ L}$

18. If λ_0 and λ be the threshold wavelength and wavelength of incident light, the velocity of photoelectron ejected from the metal surface is

- (1) $\sqrt{\frac{2hc}{m} \left(\frac{\lambda_0 - \lambda}{\lambda \lambda_0} \right)}$ (2) $\sqrt{\frac{2h}{m} \left(\frac{1}{\lambda_0} - \frac{1}{\lambda} \right)}$
 (3) $\sqrt{\frac{2h}{m} (\lambda_0 - \lambda)}$ (4) $\sqrt{\frac{2hc}{m} (\lambda_0 - \lambda)}$

Ans. (1)

Sol. $E = W + \frac{1}{2}mv^2$

$$\Rightarrow \frac{hc}{\lambda} = \frac{hc}{\lambda_0} + \frac{1}{2}mv^2$$

$$\Rightarrow v^2 = \frac{2hc}{m} \left[\frac{1}{\lambda} - \frac{1}{\lambda_0} \right] \Rightarrow v = \sqrt{\frac{2hc}{m} \left[\frac{1}{\lambda} - \frac{1}{\lambda_0} \right]}$$

$$\Rightarrow v = \sqrt{\frac{2hc}{m} \left[\frac{\lambda_0 - \lambda}{\lambda \lambda_0} \right]}$$

19. Which one of the following is used as Antihistamine?

- (1) Diphenhydramine (2) Norethindrone
 (3) Omeprazole (4) Chloranphenicol

Ans. (1)

20. The molar heat capacity (C_p) of CD_2O is 10 cal at 1000 K. The change in entropy associated with cooling of 32 g of CD_2O vapour from 1000 K to 100 K at constant pressure will be ($D = \text{deuterium, at. mass} = 2u$)

- (1) - 23.03 cal deg⁻¹ (2) 2.303 cal deg⁻¹
 (3) 23.03 cal deg⁻¹ (4) - 2.303 cal deg⁻¹

Ans. (1)

Sol. $\Delta S = nC_p \ln \left(\frac{T_2}{T_1} \right)$
 $= 2.303 \times n \times C_p \log \left(\frac{T_2}{T_1} \right)$
 $= 2.303 \times 1 \times 10 \log \frac{100}{1000}$
 $= - 23.03 \text{ cal deg}^{-1}$

21. The gas liberated by the electrolysis of Dipotassium succinate solution is

- (1) Ethyne (2) Ethene
(3) Propene (4) Ethane

Ans. (2)

22. Which of the following name formula combinations is not correct?

Formula	Name
(1) $K[Cr(NH_3)_2Cl_4]$	Potassium diammine Tetrachlorochromate
(III)	
(2) $[CO(NH_3)_4(H_2O)]SO_4$	Tetraammine aquaioido cobalt (III) sulphate
(3) $[Mn(CN)_5]^{2-}$	Pentacyanomagnate (II) ion
(4) $K_2[Pt(CN)_4]$	Potassium tetracyanoplatinate(II)

Ans. (3)

Sol. Correct Name of $[Mn(CN)_5]^{2-}$ is Pentacyanomagnate (III) ion.

23. For the reaction, $2N_2O_5 \rightarrow 4NO_2 + O_2$, the rate equation can be expressed in two ways

$$-\frac{d[N_2O_5]}{dt} = k[N_2O_5] \text{ and } +\frac{d[NO_2]}{dt} = k'[N_2O_5]$$

k and k' are related as

- (1) $k = k'$ (2) $k = 4k'$
(3) $2k = k'$ (4) $k = 2k'$

Ans. (3)

Sol. $2N_2O_5 \longrightarrow 4NO_2 + O_2$

$$-\frac{d}{dt} [N_2O_5] = k [N_2O_5]$$

Now

$$\Rightarrow -\frac{1}{2} \frac{d}{dt} [N_2O_5] = \frac{1}{4} \times K^1 [N_2O_5]$$

$$\Rightarrow 2k = k'$$

24. An organic compound A, C_5H_8O ; reacts with H_2O , NH_3 and CH_3COOH as described below:

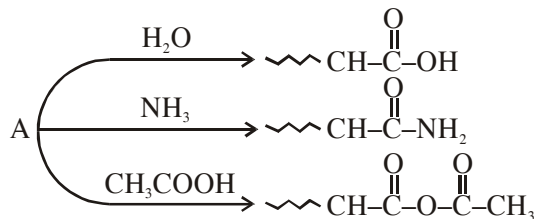

A is

- (1) $CH_3-CH_2-\underset{\substack{| \\ CH_3}}{C}=C=O$
(2) $CH_2=CH-\underset{\substack{| \\ CH_3}}{CH}-CHO$
(3) $CH_3-CH_2-\underset{\substack{|| \\ CH_2}}{C}-\underset{\substack{| \\ H}}{C}=O$
(4) $CH_3CH=\underset{\substack{| \\ CH_3}}{C}-CHO$

Ans. (1)

25. A gaseous compound of nitrogen and hydrogen contains 12.5% (by mass) of hydrogen. The density of the compound relative to hydrogen is 16. The molecular formula of the compound is :

- (1) NH_2 (2) NH_3 (3) N_3H (4) N_2H_4

Ans. (4)

Sol.

	N	H
Mass %	87.5	12.5
Mol	$\frac{87.5}{14}$	$\frac{12.5}{1}$
	= 6.25	= 12.5
	1	2

Empirical formula = NH_2

Since Vapour density = 16

$$\therefore \text{mol. wt.} = 32$$

$$\begin{aligned} \therefore \text{Molecular formula} &= n \times \text{Emp. formula} \\ &= 2 \times NH_2 \\ &= N_2H_4 \end{aligned}$$

26. Assuming that the degree of hydrolysis is small, the pH of 0.1 M solution of sodium acetate ($K_a = 1.0 \times 10^{-5}$) will be

- (1) 5.0 (2) 8.0 (3) 6.0 (4) 9.0

Ans. (4)

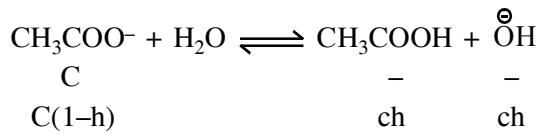
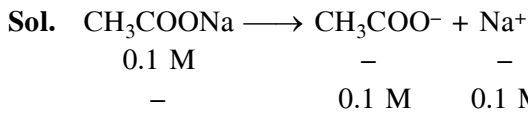

$$\Rightarrow K_h = \frac{[\text{CH}_3\text{COOH}][\overset{\ominus}{\text{O}}\text{H}]}{[\text{CH}_3\text{COO}^-]} = \frac{K_w}{K_a} = \frac{ch^2}{(1-h)}$$

$$\Rightarrow \frac{10^{-14}}{10^{-5}} = ch^2$$

{ \because h is very small $\therefore 1 - h \approx 1$ }

$$\Rightarrow h = \sqrt{\frac{10^{-9}}{0.1}} = 10^{-4}$$

$$\therefore [\overset{\ominus}{\text{O}}\text{H}] = ch = 0.1 \times 10^{-4} = 10^{-5}$$

$$\Rightarrow [\overset{\oplus}{\text{H}}] = 10^{-9}$$

$$\therefore \text{p}^{\text{H}} = -\log [\overset{\oplus}{\text{H}}] = 9$$

27. The reagent needed for converting

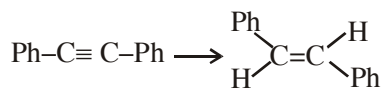

is

- (1) $\text{H}_2/\text{Lindlar Cat.}$
 (2) Cat. Hydrogenation
 (3) LiAlH_4 (4) Li/NH_3

Ans. (4)

28. Consider the coordination compound, $[\text{Co}(\text{NH}_3)_6]\text{Cl}_3$. In the formation of this complex, the species which acts as the Lewis acid is :

- (1) $[\text{Co}(\text{NH}_3)_6]^{3+}$ (2) NH_3
 (3) Co^{3+} (4) Cl^-

Ans. (3)

Sol. Metalcation i.e. Ca^{3+} act as a lewis acid which accept lone pair from ligands of NH_3 .

29. The correct order of bond dissociation energy among N_2 , O_2 , O_2^- is shown in which of the following arrangements?

- (1) $\text{N}_2 > \text{O}_2 > \text{O}_2^-$ (2) $\text{O}_2 > \text{O}_2^- > \text{N}_2$
 (3) $\text{N}_2 > \text{O}_2^- > \text{O}_2$ (4) $\text{O}_2^- > \text{O}_2 > \text{N}_2$

Ans. (1)

Sol. Bond energy \propto Bond order bondorder :-

$$\text{N}_2 = \text{Nb} = 10, \text{Na} = 4$$

$$\text{B.O.} = (\text{N}_2) = \frac{10-4}{2} = 3$$

$$\text{O}_2 = \text{Nb} = 10, \text{Na} = 6$$

$$\text{B.O.}_{(\text{O}_2)} = \frac{10-6}{2} = 2$$

$$\text{O}_2^- = \text{Nb} = 10, \text{Na} = 7$$

$$\text{B.O.}_{(\text{O}_2^-)} = \frac{10-7}{2} = \frac{3}{2} = 1.5$$

Hence the order of B.O.

$$\text{N}_2 > \text{O}_2 > \text{O}_2^-$$

30. In some solutions, the concentration of H_3O^+ remains constant even when small amounts of strong acid or strong base are added to them. These solutions are known as :-

- (1) Colloidal solutions
 (2) True solutions
 (3) Ideal solutions
 (4) Buffer solutions

Ans. (4)

PART C – MATHEMATICS

1. If X has a binomial distribution, $B(n, p)$ with parameters n and p such that $P(X = 2) = P(X = 3)$, then $E(X)$, the mean of variable X , is

- (1) $3 - p$ (2) $\frac{p}{3}$
 (3) $\frac{p}{2}$ (4) $2 - p$

Ans. (1)

Sol. $P(x = 2) = P(x = 3)$

$${}^n C_2 p^2 (1-p)^{n-2} = {}^n C_3 p^3 (1-p)^{n-3}$$

$$\frac{(1-p)}{n-2} = \frac{p}{3} \Rightarrow n p = 3 - p$$

2. The integral $\int x \cos^{-1} \left(\frac{1-x^2}{1+x^2} \right) dx (x > 0)$ is equal

to

- (1) $-x + (1+x^2) \tan^{-1} x + c$
 (2) $x - (1+x^2) \tan^{-1} x + c$
 (3) $x - (1+x^2) \cot^{-1} x + c$
 (4) $-x + (1+x^2) \cot^{-1} x + c$

Ans. (1)

Sol. put $x = \tan \theta$ $\cos^{-1} \left(\frac{1-x^2}{1+x^2} \right) = \cos^{-1}(\cos 2\theta) = 2\theta$

$$\int \tan \theta (2\theta) \sec^2 \theta d\theta$$

$$= 2\theta \cdot \int \tan \theta \sec^2 \theta d\theta - 2 \int \left(\frac{d\theta}{d\theta} \cdot \int \tan \theta \sec^2 \theta d\theta \right) d\theta$$

$$= 2\theta \cdot \frac{\tan^2 \theta}{2} - 2 \int \frac{\tan 2\theta}{2} d\theta$$

$$= \theta \tan^2 \theta - \int (\sec^2 \theta - 1) d\theta$$

$$= \theta \tan^2 \theta - \tan \theta + \theta + C$$

$$= \tan^{-1} x \cdot x^2 - x + \tan^{-1} x + C$$

$$= -x + (1+x^2) \tan^{-1} x + C$$

3. Let f be an odd function defined on the set of real numbers such that for $x \geq 0$, $f(x) = 3 \sin x + 4 \cos x$

Then $f(x)$ at $x = -\frac{11\pi}{6}$ is equal to

(1) $\frac{3}{2} - 2\sqrt{3}$ (2) $-\frac{3}{2} - 2\sqrt{3}$

(3) $-\frac{3}{2} + 2\sqrt{3}$ (4) $\frac{3}{2} + 2\sqrt{3}$

Ans. (1)

Sol. $f(-x) = -f(x)$ as $f(x)$ is odd function

$$f\left(-\frac{11\pi}{6}\right) = -\left[3 \sin\left(\frac{+11\pi}{6}\right) + 4 \cos\left(\frac{+11\pi}{6}\right)\right]$$

$$= -\left[3 \sin\left(\frac{11\pi}{6}\right) + 4 \cos\left(\frac{11\pi}{6}\right)\right]$$

$$= -\left[3 \sin\left(2\pi - \frac{\pi}{6}\right) + 4 \cos\left(2\pi - \frac{\pi}{6}\right)\right]$$

$$= +3 \sin \pi/6 - 4 \cos \frac{\pi}{6}$$

$$= 3 \times \frac{1}{2} - \frac{4\sqrt{3}}{2} = \frac{3}{2} - 2\sqrt{3}$$

4. The plane containing the line

$$\frac{x-1}{1} = \frac{y-2}{2} = \frac{z-3}{3}$$
 and parallel to the line

$$\frac{x}{1} = \frac{y}{1} = \frac{z}{4}$$
 passes through the point

- (1) (1, 0, 5)
 (2) (0, 3, -5)
 (3) (-1, -3, 0)
 (4) (1, -2, 5)

Ans. (1)

Sol. Normal vector = $\begin{vmatrix} \hat{i} & \hat{j} & \hat{k} \\ 1 & 2 & 3 \\ 1 & 1 & 4 \end{vmatrix} = 5\hat{i} - \hat{j} - \hat{k}$

point (1,2,3) lies in plane so equation of plane = $5(x-1) - 1(y-2) - 1(z-3) = 0$
 $5x - y - z = 0$

so option [1] is correct

5. The volume of the largest possible right circular cylinder that can be inscribed in a sphere of radius $=\sqrt{3}$ is

- (1) 4π (2) $\frac{4}{3}\sqrt{3}\pi$ (3) $\frac{8}{3}\sqrt{3}\pi$ (4) 2π

Ans. (1)

Sol. $h^2 + r^2 = 3$

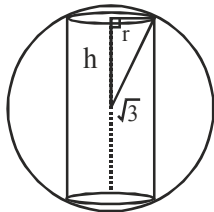

$$\therefore r^2 = 3 - h^2 \quad \dots(1)$$

$$\begin{aligned} V &= \pi r^2 \cdot 2h \\ &= 2\pi (r^2 h) \\ V &= 2\pi (3h - h^3) \end{aligned}$$

$$\frac{dV}{dh} = 0 \Rightarrow h^2 = 1 \Rightarrow h = 1$$

$$\begin{aligned} \therefore r^2 &= 3 - h^2 \\ r^2 &= 3 - 1 = 2 \end{aligned}$$

$$\text{So } V_{\max} = 2\pi (2 \times 1) = 4\pi$$

6. The proposition $\sim(p \vee \sim q) \vee \sim(p \vee q)$ is logically equivalent to

- (1) $\sim p$ (2) $\sim q$ (3) p (4) q

Ans. (1)

p	q	$\sim q$	$PV(\sim q)$	pvq	$\sim(PV \sim q)$	$\sim(pvq)$	AvB
T	T	F	T	T	F	F	F
F	F	T	T	F	F	T	T
T	F	T	T	T	F	F	F
F	T	F	F	T	T	F	T

Same as $\sim p$

7. If the general solution of the differential

equation $y' = \frac{y}{x} + \Phi\left(\frac{x}{y}\right)$, for some function Φ ,

is given by $y \ln |cx| = x$, where c is an arbitrary constant, then $\Phi(2)$ is equal to

- (1) 4 (2) -4

- (3) $\frac{1}{4}$ (4) $-\frac{1}{4}$

Ans. (4)

Sol. $y' = \frac{y}{x} + \Phi\left(\frac{x}{y}\right) \quad \dots(1)$ is solution of

$$y \ln |cx| = x \quad \dots(2)$$

d.w.r. to x

$$\frac{y}{|cx|} \cdot \frac{|cx|}{cx} \cdot c + \ln |cx| y' = 1$$

$$\frac{y}{x} + \frac{x}{y} y' = 1 \quad \left(\text{use } \ln |cx| = \frac{x}{y}\right)$$

$$y' = \left(1 - \frac{y}{x}\right) \frac{y}{x}$$

use y' in equation (1)

$$\frac{y}{x} \left(1 - \frac{y}{x}\right) = \frac{y}{x} + \Phi\left(\frac{x}{y}\right)$$

$$\text{put } \left(\frac{x}{y}\right) = 2 \Rightarrow \left(1 - \frac{1}{2}\right) \left(\frac{1}{2}\right) = \frac{1}{2} + \Phi(2)$$

$$= \frac{1}{4} = \frac{1}{2} + \Phi(2)$$

$$\Phi(2) = -\frac{1}{4}$$

8. For the curve $y = 3 \sin \theta \cos \theta$, $x = e^\theta \sin \theta$, $0 \leq \theta \leq \pi$, the tangent is parallel to x -axis when θ is

- (1) $\frac{\pi}{2}$ (2) $\frac{3\pi}{4}$ (3) $\frac{\pi}{4}$ (4) $\frac{\pi}{6}$

Ans. (3)

$$\text{Sol. } \frac{dy}{dx} = 0 \Rightarrow \frac{\left(\frac{dy}{d\theta}\right)}{\left(\frac{dx}{d\theta}\right)} = 0$$

$$\Rightarrow \frac{3[-\sin^2 \theta + \cos^2 \theta]}{e^\theta \cos \theta + \sin \theta e^\theta} = 0$$

$$\Rightarrow \frac{3 \cos 2\theta}{e^\theta (\cos \theta + \sin \theta)}$$

$$\cos 2\theta = 0$$

$$2\theta = \frac{\pi}{2}, \frac{3\pi}{2} \Rightarrow \theta = \frac{\pi}{4}, \frac{3\pi}{4}$$

Reject $(3\pi/4)$ because at $\theta = \frac{3\pi}{4}$

Denominator $\cos \theta + \sin \theta = 0$

$$\text{So } \theta = \frac{\pi}{4} \text{ ans}$$

9. If for $n \geq 1$, $P_n = \int_1^e (\log x)^n dx$, then $P_{10} - 90P_8$

is equal to

- (1) $10e$ (2) 10
 (3) -9 (4) $-9e$

Ans. (4)

Sol. $P_n = \int_1^e (\log x)^n \cdot 1 dx$

Integrate by parts

$$P_n = \left(x(\log x)^n \right)_1^e - \int_1^e x n (\log x)^{n-1} \cdot \frac{1}{x} dx$$

$$P_n = e - n P_{n-1} \Rightarrow P_n + n P_{n-1} = e$$

$$\text{put } n = 10 \quad P_{10} + 10P_9 = e \quad \dots(1)$$

$$n = 9 \quad P_9 + 9P_8 = e \quad \dots(2)$$

$$\text{use (2) in (1)} \quad P_{10} + 10(e - 9P_8) = e$$

$$P_{10} - 90P_8 = e - 10e \\ = -9e$$

10. Let $f(x) = x|x|$, $g(x) = \sin x$ and $h(x) = (g \circ f)(x)$. Then

- (1) $h'(x)$ is differentiable at $x = 0$
 (2) $h'(x)$ is continuous at $x = 0$ but is not differentiable at $x = 0$
 (3) $h(x)$ is differentiable at $x = 0$ but $h'(x)$ is not continuous at $x = 0$
 (4) $h(x)$ is not differentiable at $x = 0$

Ans. (2)

Sol. $h(x) = \begin{cases} \sin x^2 & x \geq 0 \\ -\sin x^2 & x < 0 \end{cases}$

$$h'(x) = \begin{cases} 2x \cos x^2 & x \geq 0 \\ -2x \cos x^2 & x < 0 \end{cases}$$

$$h'(0) = h'(0^+) = h'(0^-)$$

so $h'(x)$ is continuous at $x = 0$

$$h''(x) = \begin{cases} 2[\cos x^2 - 2x^2 \sin x^2] & x \geq 0 \\ -2[\cos x^2 - 2x^2 \sin x^2] & x < 0 \end{cases}$$

$h''(0^+) \neq h''(0^-)$ so $h''(x)$ is not continuous at $x = 0$

so $h'(x)$ is not differentiable at $x = 0$

11. A set S contains 7 elements. A non-empty subset A of S and an element x of S are chosen at random. Then the probability that $x \in A$ is

- (1) $\frac{64}{127}$ (2) $\frac{63}{128}$ (3) $\frac{1}{2}$ (4) $\frac{31}{128}$

Ans. (1)

Sol. Total non empty subsets = $2^7 - 1 = 127$

Let $x \in S$ also present in A

So no. of A 's containing $x = 2^6$

$$\text{Probability} = \frac{2^6}{127}$$

12. If $\lim_{x \rightarrow 2} \frac{\tan(x-2)\{x^2 + (k-2)x - 2k\}}{x^2 - 4x + 4} = 5$ then k

is equal to

- (1) 3 (2) 1 (3) 0 (4) 2

Ans. (1)

Sol. $\lim_{x \rightarrow 2} \frac{\tan(x-2) [x^2 + kx - 2k - 2x]}{(x-2)^2} = 5$

$$\lim_{x \rightarrow 2} \left(\frac{\tan(x-2)}{(x-2)} \right) \frac{(x+k)(x-2)}{(x-2)} = 5$$

$$1. (2+k) = 5$$

$$K = 3$$

13. Let $P(3\sec\theta, 2\tan\theta)$ and $Q(3\sec\phi, 2\tan\phi)$ where

$\theta + \phi = \frac{\pi}{2}$, be two distinct points on the

hyperbola $\frac{x^2}{9} - \frac{y^2}{4} = 1$. Then the ordinate of

the point of intersection of the normals at P and Q is

- (1) $\frac{-11}{3}$ (2) $\frac{-13}{2}$ (3) $\frac{13}{2}$ (4) $\frac{11}{3}$

Ans. (2)

Sol. $p(3 \sec \theta, 2 \tan \theta)$ $Q = (3 \sec \phi, 2 \tan \phi)$

$$\theta + \phi = \frac{\pi}{2} \quad Q = (3 \operatorname{cosec} \theta, 2 \cot \theta)$$

Equation of normal at $p =$

$$= 3x \cos \theta + 2y \cot \theta = 13$$

$$= 3x \sin \theta \cos \theta + 2y \cos \theta = 13 \sin \theta \dots(1)$$

equation of normal at $Q \Rightarrow$

$$= 3x \sin \theta + 2y \tan \theta = 13$$

$$= 3x \sin \theta \cos \theta + 2y \sin \theta = 13 \cos \theta \dots(2)$$

$$(1)-(2) \Rightarrow$$

$$2y (\cos \theta - \sin \theta) = 13 (\sin \theta - \cos \theta)$$

$$2y = -13 \Rightarrow y = \frac{-13}{2}$$

14. In a geometric progression, if the ratio of the sum of first 5 terms to the sum of their reciprocals is 49, and the sum of the first and the third term is 35. Then the first term of this geometric progression is

- (1) 42 (2) 28
(3) 21 (4) 7

Ans. (2)

Sol. Let first term is a & C.R = r

$$\text{given } \frac{(a + ar + ar^2 + ar^3 + ar^4)}{\left(\frac{1}{a} + \frac{1}{ar} + \frac{1}{ar^2} + \frac{1}{ar^3} + \frac{1}{ar^4}\right)} = 49$$

$$a^2 r^4 = 49 \Rightarrow ar^2 = 7, -7$$

$$\text{also given that } a + ar^2 = 35$$

$$\text{if } ar^2 = 7 \Rightarrow a = 35 - 7 = 28$$

$$\text{if } ar^2 = -7 \Rightarrow a = 35 + 7 = 42$$

$$\text{but if } a = 42 \text{ then } r^2 = -\frac{7}{42}$$

which is not possible so

$$a = 28$$

15. Let $A \{2, 3, 5\}$, $B (-1, 3, 2)$ and $C(\lambda, 5, \mu)$ be the vertices of a ΔABC . If the median through A is equally inclined to the coordinate axes, then

- (1) $8\lambda - 5\mu = 0$ (2) $10\lambda - 7\mu = 0$
(3) $5\lambda - 8\mu = 0$ (4) $7\lambda - 10\mu = 0$

Ans. (2)

Sol. Mid point of B & C is $\left(\frac{\lambda-1}{2}, 4, \frac{\mu+2}{2}\right)$

$$\text{Let say } D = \left(\frac{\lambda-1}{2}, 4, \frac{\mu+2}{2}\right)$$

$$A = (2, 3, 5)$$

$$\text{DR's of AD} = \frac{\lambda-5}{2}, 1, \frac{\mu-8}{2}$$

$$\lambda = 7 \text{ \& } \mu = 10$$

$$\Rightarrow \lambda = \frac{\lambda}{10} = \frac{\mu}{10} \Rightarrow 10\lambda - 7\mu = 0$$

16. The set of all real values of λ for which exactly two common tangents can be drawn to the circles

$$x^2 + y^2 - 4x - 4y + 6 = 0 \text{ and}$$

$$x^2 + y^2 - 10x - 10y + \lambda = 0 \text{ is the interval}$$

- (1) (18, 48) (2) (12, 24)
(3) (18, 42) (4) (12, 32)

Ans. (3)

Sol. $C_1 (2, 2) C_2 (5, 5)$

$$r_1 = \sqrt{2} \quad r_2 = \sqrt{50} - 1$$

$$|r_1 - r_2| < c_1 c_2 < r_1 + r_2$$

$$\left| \sqrt{50 - \lambda} - \sqrt{2} \right| < \sqrt{9 + 9} < \sqrt{50 - \lambda} + \sqrt{2}$$

$$-18 < \left[\sqrt{50 - \lambda} - \sqrt{2} \right] < 18 \quad \left| \begin{array}{l} \sqrt{18 - \sqrt{2}} < \sqrt{50 - \lambda} \\ 20 - 12 < 50 - \lambda \\ \lambda < 42 \end{array} \right.$$

$$\lambda \in (18, 42)$$

17. If z_1, z_2 and z_3, z_4 are 2 pairs of complex conjugate numbers, then

$$\arg\left(\frac{z_1}{z_4}\right) + \arg\left(\frac{z_2}{z_3}\right) \text{ equals}$$

- (1) 0 (2) $\frac{\pi}{2}$ (3) $\frac{3\pi}{2}$ (4) π

Ans. (1)

Sol. $Z_2 = \bar{Z}_1$ & $Z_4 = \bar{Z}_3$

$$\arg\left(\frac{Z_1}{Z_4}\right) + \arg\left(\frac{Z_2}{Z_3}\right)$$

$$= \arg Z_1 - \arg Z_4 + \arg Z_2 - \arg Z_3$$

$$= \arg Z_1 - \arg \bar{Z}_3 + \arg \bar{Z}_1 - \arg Z_3$$

$$= \arg Z_1 + \arg Z_3 - \arg Z_1 - \arg Z_3 = 0$$

18. If $2\cos\theta + \sin\theta = 1 \left(\theta \neq \frac{\pi}{2}\right)$,

then $7\cos\theta + 6\sin\theta$ is equal to

- (1) $\frac{1}{2}$ (2) $\frac{46}{5}$ (3) 2 (4) $\frac{11}{2}$

Ans. (2)

Sol. $2 \cos \theta + \sin \theta = 1 \dots(1)$

$7 \cos \theta + 6 \sin \theta = k$ (let) $\dots(2)$

$$\text{from (1) \& (2) } \boxed{\cos \theta = \frac{6-k}{5}} \quad \boxed{\sin \theta = \frac{2k-7}{5}}$$

$$\therefore \sin^2 \theta + \cos^2 \theta = 1$$

$$\Rightarrow (6 - K)^2 + (2k - 7)^2 = 25$$

$$\Rightarrow K = 2$$

19. An eight digit number divisible by 9 is to be formed using digits from 0 to 9 without repeating the digits. The number of ways in which this can be done is :

- (1) 18 (7!) (2) 40 (7!)
 (3) 36 (7!) (4) 72 (7!)

Ans. (3)

Sol. Eight digit no divisible by 9 i.e. sum of digits divisible by 9

- (i) Total no formed by 1,2,3,4,5,6,7,8 = 8!
 (ii) Total no formed by 0,2,3,4,5,6,7,9 = 7×7!
 (iii) Total no formed by 1,0,3,4,5,6,9,8 = 7×7!
 (iv) Total no formed by 1,2,0,4,5,9,7,8 = 7×7!
 (v) Total no formed by 1,2,3,0,5,6,7,8 = 7×7!
 $8! + 28 \times 7!$
 $= 36 \times 7!$

20. The coefficient of x^{50} in the binomial expansion of

$(1+x)^{1000} + x(1+x)^{999} + x^2(1+x)^{998} + \dots + x^{1000}$ is

- (1) $\frac{(1000)!}{(50)!(950)!}$ (2) $\frac{(1001)!}{(50)!(951)!}$
 (3) $\frac{(1000)!}{(49)!(951)!}$ (4) $\frac{(1001)!}{(51)!(950)!}$

Ans. (2)

Sol. Coefficient of x^{50} in

$$= (1+x)^{1000} \left[\frac{1 - \left(\frac{x}{1+x}\right)^{1000}}{1 - \frac{x}{1+x}} \right]$$

$$= (1+x)^{1001} - x^{1001}$$

coefficient of $x^{50} = {}^{1001}C_{50} = \frac{(1001)!}{(50)!(951)!}$

21. Let L_1 be the length of the common chord of the curves $x^2 + y^2 = 9$ and $y^2 = 8x$, and L_2 be the length of the latus rectum of $y^2 = 8x$ then

- (1) $L_1 < L_2$ (2) $L_1 > L_2$
 (3) $\frac{L_1}{L_2} = \sqrt{2}$ (4) $L_1 = L_2$

Ans. (1)

Sol. $x^2 + y^2 = 9$ & $y^2 = 8x$

$L_2 = \text{L.R. of } y^2 = 8x \Rightarrow L_2 = 8$

Solve $x^2 + 8x = 9 \Rightarrow x = 1, -9$

$x = -9$ reject

$\therefore y^2 = 8x$ so $y^2 = 8$

$y = \pm \sqrt{8}$

Point of intersection are $(1, \sqrt{8})$ $(1, -\sqrt{8})$

So $L_1 = 2\sqrt{8}$

$$\frac{L_1}{L_2} = \frac{2\sqrt{8}}{8} = \frac{2}{\sqrt{8}} = \frac{1}{\sqrt{2}} < 1$$

$L_1 < L_2$

22. The angle of elevation of the top of a vertical tower from a point P on the horizontal ground was observed to be α . After moving a distance 2 metres from P towards the foot of the tower, the angle of elevation changes to β . Then the height (in metres) of the tower is

- (1) $\frac{\cos(\beta - \alpha)}{\sin \alpha \sin \beta}$
 (2) $\frac{2 \sin \alpha \sin \beta}{\sin(\beta - \alpha)}$
 (3) $\frac{2 \sin(\beta - \alpha)}{\sin \alpha \sin \beta}$
 (4) $\frac{\sin \alpha \sin \beta}{\cos(\beta - \alpha)}$

Ans. (2)

Sol. From figure

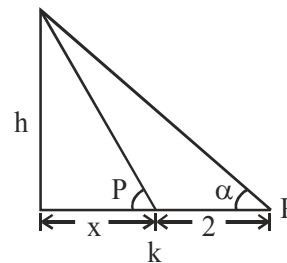

$$\tan \alpha = \frac{h}{x+2} \text{ \& \ } \tan \beta = \frac{h}{x}$$

$$x \tan \alpha + 2 \tan \alpha = h$$

$$h \frac{\tan \alpha}{\tan \beta} + 2 \tan \alpha = h$$

$$h = \frac{2 \sin \alpha \sin \beta}{\sin(\beta - \alpha)}$$

23. Two ships A and B are sailing straight away from a fixed point O along routes such that $\angle AOB$ is always 120° . At a certain instance, $OA = 8$ km, $OB = 6$ km and the ship A is sailing at the rate of 20 km/hr while the ship B sailing at the rate of 30 km/hr. Then the distance between A and B is changing at the rate (in km/hr)

- (1) $\frac{260}{37}$ (2) $\frac{80}{37}$
 (3) $\frac{80}{\sqrt{37}}$ (4) $\frac{260}{\sqrt{37}}$

Ans. (4)

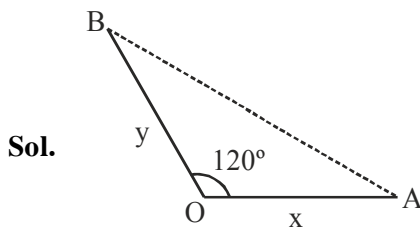

Let at any time t

$$OA = x \quad OB = y$$

$$\frac{dx}{dt} = 20 \quad \frac{dy}{dt} = 30$$

$$\cos(120^\circ) = \frac{x^2 + y^2 - AB^2}{2xy}$$

$$AB^2 = x^2 + y^2 + xy \quad \dots(1)$$

D.w.R. To . t

$$2(AB) \frac{d}{dt}(AB) = 2x \frac{dx}{dt} + 2y \frac{dy}{dt} + 2 \frac{dy}{dt} + y \frac{dx}{dt} \quad \dots(2)$$

when $x = 8$ $y = 6$ then $AB = \sqrt{148}$ from (1)

$$\text{So } \frac{d}{dt}(AB) = \frac{\left(2x \frac{dx}{dt} + 2y \frac{dy}{dt} + \frac{xdy}{dt} + y \frac{dx}{dt}\right)}{2AB}$$

$$\text{use } x = 8 \quad y = 6 \quad AB = \sqrt{148}$$

$$\frac{d}{dt}(AB) = 260 / \sqrt{37}$$

24. If α and β are roots of the equation

$$x^2 - 4\sqrt{2}kx + 2e^{4\ln k} - 1 = 0 \text{ for some } k, \text{ and}$$

$$\alpha^2 + \beta^2 = 66, \text{ then } \alpha^3 + \beta^3 \text{ is equal to}$$

- (1) $248\sqrt{2}$ (2) $280\sqrt{2}$
 (3) $-32\sqrt{2}$ (4) $-280\sqrt{2}$

Ans. (2)

$$\text{Sol. } x^2 - 4\sqrt{2}kx + 2k^4 - 1 = 0$$

$$\alpha + \beta = 4\sqrt{2}k$$

$$\alpha\beta = 2k^4 - 1$$

$$\Rightarrow \alpha^2 + \beta^2 = 66$$

$$(\alpha + \beta)^2 - 2\alpha\beta = 66$$

$$32k^2 - 2(2k^4 - 1) = 66$$

$$2(2k^4) - 32k^2 + 64 = 0$$

$$4(k^2 - 4)^2 = 0 \Rightarrow k^2 = 4 \Rightarrow k = 2$$

$$\alpha^3 + \beta^3 = (\alpha + \beta)^3 - 3\alpha\beta(\alpha + \beta)$$

$$= (\alpha + \beta)(\alpha^2 + \beta^2 - \alpha\beta)$$

$$= (8\sqrt{2})(66 - 31) = 280\sqrt{2}$$

25. Let for $i = 1, 2, 3$ $p_i(x)$ be a polynomial of degree 2 in x , $p_i'(x)$ and $p_i''(x)$ be the first and second order derivatives of $p_i(x)$ respectively.

$$\text{Let, } A(x) = \begin{bmatrix} p_1(x) & p_1'(x) & p_1''(x) \\ p_2(x) & p_2'(x) & p_2''(x) \\ p_3(x) & p_3'(x) & p_3''(x) \end{bmatrix}$$

and $B(x) = [A(x)]^T A(x)$. Then determinant of $B(x)$

- (1) Does not depend on x
 (2) Is a polynomial of degree 6 in x
 (3) Is a polynomial of degree 3 in x
 (4) Is a polynomial of degree 2 in x

Ans. (1)

Sol. Let $P_i = a_i x^2 + b_i x + c_i$ $a_i \neq 0$

$$b_i, c_i \in \mathbb{R}$$

$$A(x) = \begin{bmatrix} a_1 x^2 + b_1 x + c_1 & 2a_1 x + b_1 & 2a_1 \\ a_2 x^2 + b_2 x + c_2 & 2a_2 x + b_2 & 2a_2 \\ a_3 x^2 + b_3 x + c_3 & 2a_3 x + b_3 & 2a_3 \end{bmatrix}$$

use (i) $C_2 \rightarrow C_2 - x C_3$

then use (ii) $C_1 \rightarrow C_1 - x C_2 - \frac{x^2}{2} C_3$

$$A(x) = \begin{bmatrix} c_1 & b_1 & 2a_1 \\ c_2 & b_2 & 2a_2 \\ c_3 & b_3 & 2a_3 \end{bmatrix} \Rightarrow |A| = \text{constant}$$

So $|B| = |A^T| |A| = |A|^2 = \text{constant independent from } n$

26. The sum of the first 20 terms common between the series $3 + 7 + 11 + 15 + \dots$ and

$1 + 6 + 11 + 16 + \dots$, is :

- (1) 4220 (2) 4020
 (3) 4000 (4) 4200

Ans. (2)

Sol. from x

A.P₁ = 3, 7, 11, 15 $d_1 = 4$

A.P₂ = 1, 6, 11, 16 $d_2 = 5$

1st common term = 11 $d = \text{LCM}(d_1, d_2)$

$d = 20$

New A.P of common terms having

$a = 11$ as 1st term & $d = 20$

$$\begin{aligned} \text{sum of 20 term} &\Rightarrow \frac{20}{2} [2 \times 11 + 19 \times 20] \\ &= 4020 \end{aligned}$$

27. If $|\vec{c}|^2 = 60$ and $\vec{c} \times (\hat{i} + 2\hat{j} + 5\hat{k}) = \vec{0}$, then a value of $\vec{c} \cdot (-7\hat{i} + 2\hat{j} + 3\hat{k})$ is

- (1) $4\sqrt{2}$ (2) 24 (3) $12\sqrt{2}$ (4) 12

Ans. (3)

Sol. $\vec{C} \times (\hat{i} + 2\hat{j} + 5\hat{k}) = 0$

$\vec{C} = \lambda(\hat{i} + 2\hat{j} + 5\hat{k})$

$|\vec{C}| = \lambda \sqrt{30} \Rightarrow \lambda^2 (30) = |\vec{c}|^2 = 60$

$\lambda = \pm\sqrt{2}$

$\Rightarrow \vec{C} \cdot (-7\hat{i} + 2\hat{j} + 3\hat{k})$

$\Rightarrow \lambda (i + 2j + 5k) \cdot (-7i + 2j + 3k)$

$\Rightarrow \lambda (-7 + 4 + 15) = 12\lambda$

$= 12\sqrt{2}$ or $-12\sqrt{2}$

28. Let A be a 3×3 matrix such that

$$A \begin{bmatrix} 1 & 2 & 3 \\ 0 & 2 & 3 \\ 0 & 1 & 1 \end{bmatrix} = \begin{bmatrix} 0 & 0 & 1 \\ 1 & 0 & 0 \\ 0 & 1 & 0 \end{bmatrix}$$

Then A^{-1} is

(1) $\begin{bmatrix} 3 & 2 & 1 \\ 3 & 2 & 0 \\ 1 & 1 & 0 \end{bmatrix}$ (2) $\begin{bmatrix} 3 & 1 & 2 \\ 3 & 0 & 2 \\ 1 & 0 & 1 \end{bmatrix}$

(3) $\begin{bmatrix} 0 & 1 & 3 \\ 0 & 2 & 3 \\ 1 & 1 & 1 \end{bmatrix}$ (4) $\begin{bmatrix} 1 & 2 & 3 \\ 0 & 1 & 1 \\ 0 & 2 & 3 \end{bmatrix}$

Ans. (2)

Sol. $\therefore AA^{-1} = I$

given $A \begin{bmatrix} 1 & 2 & 3 \\ 0 & 2 & 3 \\ 0 & 1 & 1 \end{bmatrix} = \begin{bmatrix} 0 & 0 & 1 \\ 1 & 0 & 0 \\ 0 & 1 & 0 \end{bmatrix}$

use column transformation and make RHS as I

(i) $C_1 \leftrightarrow C_3$ $A \begin{bmatrix} 3 & 2 & 1 \\ 3 & 2 & 0 \\ 1 & 1 & 0 \end{bmatrix} = \begin{bmatrix} 1 & 0 & 0 \\ 0 & 0 & 1 \\ 0 & 1 & 0 \end{bmatrix}$

(ii) $C_2 \leftrightarrow C_3$ $A \begin{bmatrix} 3 & 1 & 2 \\ 3 & 0 & 2 \\ 1 & 0 & 1 \end{bmatrix} = \begin{bmatrix} 1 & 0 & 0 \\ 0 & 1 & 0 \\ 0 & 0 & 1 \end{bmatrix}$

$A^{-1} = \begin{bmatrix} 3 & 1 & 2 \\ 3 & 0 & 2 \\ 1 & 0 & 1 \end{bmatrix}$

29. A stair-case of length l rests against a vertical wall and a floor of a room. Let P be a point on the stair-case, nearer to its end on the wall, that divides its length in the ratio 1 : 2. If the stair-case begins to slide on the floor, then the locus of P is :

(1) An ellipse of eccentricity $\frac{\sqrt{3}}{2}$

(2) A circle of radius $\frac{l}{2}$

(3) An ellipse of eccentricity $\frac{1}{2}$

(4) A circle of radius $\frac{\sqrt{3}}{2}l$

Ans. (1)

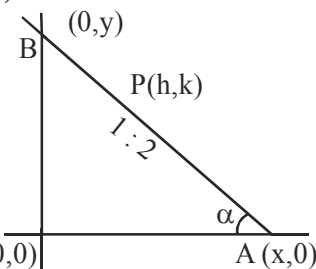

Sol.

Let any time one end is A (x, 0) & other end B(0, y) so

$$\ell^2 = x^2 + y^2 \quad \dots(1)$$

Let P is (h, k) using section formula

$$(h, k) = \left(\frac{x}{3}, \frac{2y}{3}\right)$$

$$x = 3h \text{ \& } y = \frac{3k}{2}$$

use in (1)

$$9h^2 + \frac{9k^2}{4} = \ell^2$$

Locus of Pt p is ellipse

which equation is $\left(9x^2 + \frac{9y^2}{4} = \ell^2\right)$

$$\frac{x^2}{\left(\frac{\ell^2}{9}\right)} + \frac{y^2}{\left(\frac{4\ell^2}{9}\right)} = 1$$

$$e = \sqrt{1 - \frac{\ell^2}{9 \times \frac{4\ell^2}{9}}} = \frac{\sqrt{3}}{2}$$

30. The base of an equilateral triangle is along the line given by $3x + 4y = 9$. If a vertex of the triangle is (1, 2), then the length of a side of the triangle is :

(1) $\frac{4\sqrt{3}}{15}$ (2) $\frac{4\sqrt{3}}{5}$ (3) $\frac{2\sqrt{3}}{15}$ (4) $\frac{2\sqrt{3}}{5}$

Ans. (1)

Sol. Let BC is base of equilateral triangle ABC with side a and A (1, 2)

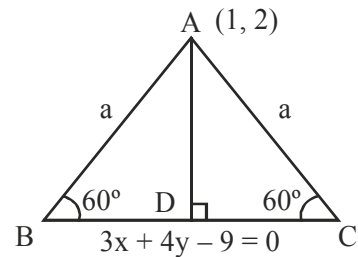

$$AD = a \sin 60^\circ$$

AD is perpendicular distance of PtA from line $3x + 4y - 9 = 0$

$$AD = \left| \frac{3 \times 1 + 4 \times 2 - 9}{\sqrt{3^2 + 4^2}} \right|$$

$$a \sin 60^\circ = \frac{2}{5}$$

$$a = \frac{4}{5\sqrt{3}} = \frac{4\sqrt{3}}{15}$$