

## SECTION – A

1. Mobility of the charge carrier is defined as the drift velocity of the charge carrier per unit electric field

It is denoted by  $\mu$  and is given as

$$\mu = \frac{v_d}{E}$$

The SI unit of  $\mu$  is  $\text{m}^2 \text{V}^{-1} \text{s}^{-1}$ .

2. In an LCR series circuit, power dissipated is given by

$$P = I^2 Z \cos \Phi$$

$$\frac{P}{I^2 \sqrt{R^2 + (X_C - X_L)^2}}$$

$$\because V_L = V_C \text{ and } X_L = X_C$$

$$\therefore \cos \Phi = \frac{P}{I^2 R}$$

3. The focal length and the radius of curvature of a lens are equal if the lens is made of glass having a refractive index of 1.5
4. The relation for polarisation  $\vec{P}$  of a dielectric material in the presence of an external electric field  $\vec{E}$  is

$$P = \chi_e E$$

Where  $\chi_e$  is a constant characteristic of the dielectric and is known as the electric susceptibility of the dielectric medium.

5. In forward biasing, the applied voltage mostly drops across the depletion region, and the voltage drop across the p-side and n-side of the junction is negligible. The direction of the applied voltage (V) is opposite to the built-in potential  $V_0$ . As a result, the depletion layer width decreases and the barrier height is reduced. The effective barrier height under forward bias is  $(V_0 - V)$ .

6.

Analog form of communication	Digital form of communication
It makes use of analog signals whose amplitude varies continuously with time.	It makes use of digital signals whose amplitude is of two levels, either low or high.
The retrieved message in analog communication is not an exact copy of the original message. This is because the message suffers distortions over the medium and during its detection process and is distorted.	The retrieved message in digital communication is always the exact copy of the original message and is practically free of distortion.
It can broadcast only limited number of channels simultaneously.	It can broadcast tremendously large number of channels simultaneously.

(b) Applications of the Internet:

1. E-mail: It allows the exchange of text or graphic material. One can write a letter and send it to the other person (recipient) through an internet service provider (ISP). The ISP works like the dispatching and receiving post office.
  2. File transfer: A program known as the file transfer program (FTP) allows the transfer of files or software from one computer to the other computer connected to the Internet.
7. Ground state energy is  $E_0 = -13.6\text{eV}$

$$\text{Energy in the first excited state} = E_1 = \frac{-13.6\text{eV}}{(2)^2} = -3.4\text{eV}$$

We know that, the de Broglie wavelength  $\lambda$  is given as

$$\lambda = \frac{h}{p}$$

$$\text{But, } p = \sqrt{2mE_1}$$

$$\therefore \lambda = \frac{h}{\sqrt{2mE_1}}$$

$$= \frac{6.63 \times 10^{-34}}{\sqrt{2 \times (9.1 \times 10^{-31}) \times (3.4 \times 1.6 \times 10^{-19})}}$$

$$= \frac{6.63 \times 10^{-34}}{9.95 \times 10^{-25}}$$

$$\lambda = 6.6 \times 10^{-10} \text{ m}$$

8. Bohr's third postulate successfully explains emission lines. It states that 'Whenever an electron jumps from one of its specified non-radiating orbit to another such orbit, it emits or absorbs a photon whose energy is equal to the energy difference between the initial and final states'.

Thus,

$$E_i - E_f = h\nu = \frac{hc}{\lambda}$$

The Rydberg formula for the Balmer series is given as

$$\frac{1}{\lambda} = R \left( \frac{1}{n_f^2} - \frac{1}{n_i^2} \right)$$

'R' is a constant called the Rydberg constant and its value is  $1.03 \times 10^7 \text{ m}^{-1}$ . The  $H_\alpha$ -line of the Balmer series is obtained when an electron jumps to the second orbit ( $n_f = 2$ ) from the third orbit ( $n_i = 3$ )

$$\frac{1}{\lambda} = 1.03 \times 10^7 \left( \frac{1}{2^2} - \frac{1}{3^2} \right)$$

$$\frac{1}{\lambda} = 1.03 \times 10^7 \left( \frac{1}{4} - \frac{1}{9} \right)$$

$$\frac{1}{\lambda} = 1.03 \times 10^7 \left( \frac{9-4}{9 \times 4} \right)$$

$$\frac{1}{\lambda} = 1.03 \times 10^7 \left( \frac{5}{36} \right)$$

$$\lambda = \frac{36}{5 \times 1.03 \times 10^7}$$

$$\lambda = 6.99 \times 10^{-7}$$

$$\lambda = 699 \times 10^{-2} \times 10^{-7}$$

$$\lambda = 699 \text{ nm}$$

The value of  $\lambda$  lies in the visible region.

9. Kirchoff's first rule: In any electrical network, the algebraic sum of currents meeting at a junction is always zero

$$\Sigma I = 0$$

In the junction below, let  $I_1, I_2, I_3, I_4$  and  $I_5$  be the current in the conductors with directions as shown in the figure below.  $I_5$  and  $I_3$  are the currents which enter and currents  $I_1, I_2$  and  $I_4$  leave.

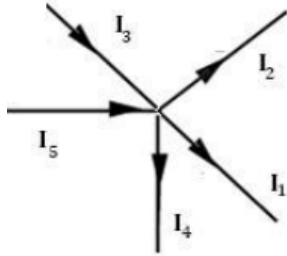

According to the Kirchhoff's law, we have

$$(-I_1)+(-I_2)+(-I_3)+(-I_4)+I_5=0$$

$$\text{Or, } I_1+I_2+I_4=I_3+I_5$$

Thus, at any junction of several circuit elements, the sum of currents entering the junction must equal the sum of currents leaving it. This is a consequence of charge conservation and the assumption that currents are steady, i.e. no charge piles up at the junction.

Kirchhoff's second rule: The algebraic sum of changes in potential around any closed loop involving resistors and cells in the loop is zero.

**OR**

The algebraic sum of the e.m.f. in any loop of a circuit is equal to the algebraic sum of the products of currents and resistances in it

Mathematically, the loop rule may be expressed as  $\Sigma E = \Sigma IR$ .

10. Important characteristic features:

1. Interference is the result of the interaction of light coming from two different waves originating from two coherent sources, whereas the diffraction pattern is the result of the interaction of light coming from different parts of the same wavefront
2. The fringes may or may not be of the same width in case of interference, while the fringes are always of varying width in diffraction.
3. In interference, the fringes of minimum intensity are perfectly dark and all bright fringes are of the same intensity. In diffraction, the fringes of minimum intensity are not perfectly dark and the bright fringes are of varying intensity
4. There is a good contrast between the bright and dark fringes in the interference pattern. The contrast between the bright and dark fringes in the diffraction pattern is comparatively poor.

OR

Telescope	Microscope
It is used for observing distant images of heavenly bodies such as stars and planets.	It is used for observing magnifying images of tiny objects.

The objective lens has a large focal length and large aperture.	The objective lens has a small focal length and short aperture.
The eye lens used has small focal length and small aperture.	The eye lens used has moderate focal length and large aperture.
The distance between the objective lens and eye lens is adjusted to focus the object situated at infinity.	The objective and eye lens are kept at a fixed distance apart, whereas the distance of the objective lens from the object is adjusted to focus an object.

**SECTION –C**

11. (i) Keeping the anode potential and the frequency of the incident radiation constant, if the intensity of the incident light is increased, the photoelectric current or the anode current increases linearly. This is because photoelectric current is directly proportional to the number of photoelectrons emitted per second which is directly proportional to the intensity of the incident radiation.
- (ii) For photoelectric emission to occur, there is a minimum cut off frequency of the incident radiation called the threshold frequency below which no photoelectric emission occurs. This frequency is independent of the intensity of the incident light. With an increase in the frequency of the incident radiation, the kinetic energy of the photoelectrons ejected increases, whereas it is independent of the number of photoelectrons ejected. Hence, with the increase in the frequency of incident radiation, there will not be any change in the anode current.
- (iii) With an increase in the accelerating potential, the photoelectric current increases first, reaches maximum when all the electrons gets collected at the positive potential plate and then remains constant. The maximum value of the anode current is called the saturation current.
12. .If the bias of the emitter-base junction of a transistor is sufficient to send a forward current and the collector base junction is reversed biased, the transistor is said to be in the active state  
The circuit diagram of a p–n–p transistor is as shown below:

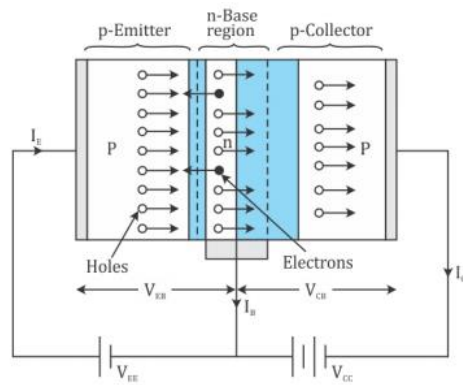

A transistor when operated in the active state acts as an amplifier. The working of a common emitter transistor as an amplifier is based on the principle that a weak input signal given to the base region produces an amplified output signal in the collector region.

The circuit diagram for a p–n–p common emitter transistor amplifier can be drawn as shown below:

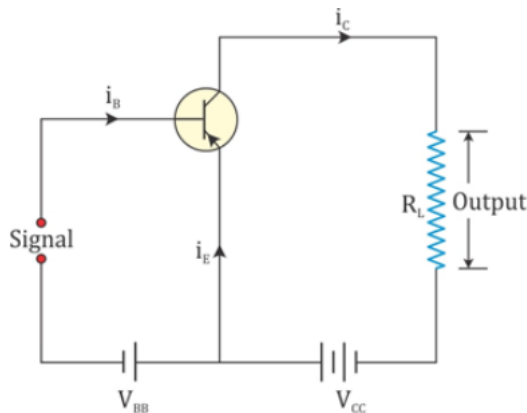

The battery  $V_{BB}$  forward biases the emitter base junction and the battery  $V_{CC}$  reverse biases the emitter collector region. The e.m.f. of the batteries should be greater than the barrier potential across base-emitter and collector emitter junction. The output current produces a potential difference across the load resistance  $R_L$ . A weak alternating signal is applied between the base and the emitter. When the signal increases in the positive direction, the base current also increases. The base current is amplified  $\beta$  times and appears at the collector. The collector current flowing through the collector load resistance produces a voltage. This output voltage is equal to the collector current times the load resistance. Thus, an amplified output is obtained. The voltage gain = output voltage/input voltage.

In a transistor, the base is thin and lightly doped so that it contains smaller number of majority carriers. This reduces the recombination rate of free electrons and holes in the base region when the majority carriers go from the emitter to the collector. On the other hand, the emitter region in a transistor is heavily doped because the emitter supplies the majority carriers for the current flow.

13. (a) Sound waves of frequency 20–20,000 Hz cannot be transmitted from a radio transmitter by converting them into electrical waves directly. Such low frequency signals need to be translated into high frequency waves before transmission. Three reasons for this are
- For efficient transmission and reception, the transmitting and receiving antennas must have lengths equal to quarter wavelength of the audio signal. Setting up vertical antennas of such size is practically impossible.
  - The energy radiated from an antenna is practically zero. The power radiated at audio frequency is quite small; hence, transmission occurs in loss.
  - The various information signals transmitted at low frequency get mixed and hence cannot be distinguished.

(b)

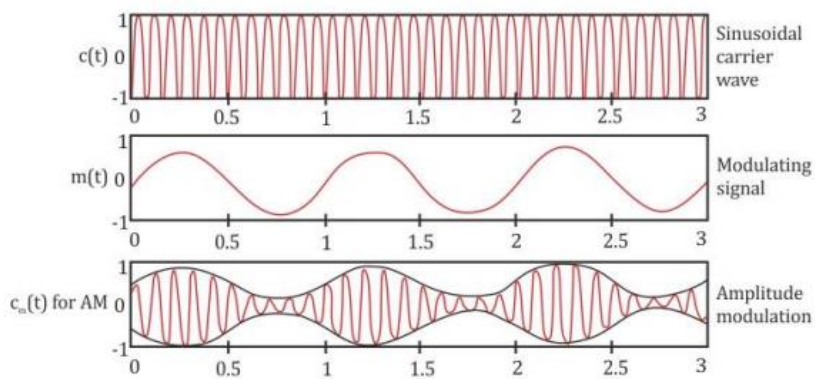

14. When the element X is connected across an a.c. source of a given voltage, the current is in phase with the applied voltage. This implies that the circuit element X is a resistance R.
- When the circuit element Y is connected in series with X across an a.c. source, the voltage is found to lead the current by a phase angle  $\pi/4$ . This indicates that the circuit element Y is an inductance L.
- The circuit element Z is a capacitance C as it is found that the current leads the voltage by a phase angle  $\pi/4$ .

When the three circuit elements—resistance, inductance and capacitance—are connected in series with the a.c. source, the impedance of the circuit is given by

$$Z = \sqrt{R^2 + (X_L + X_C)^2}$$

where R is the resistance,  $X_L$  is the inductive reactance and  $X_C$  is the capacitive reactance.

The variation of current with the changing frequency of applied voltage in a circuit in which X, Y and Z are connected in series is as shown below:

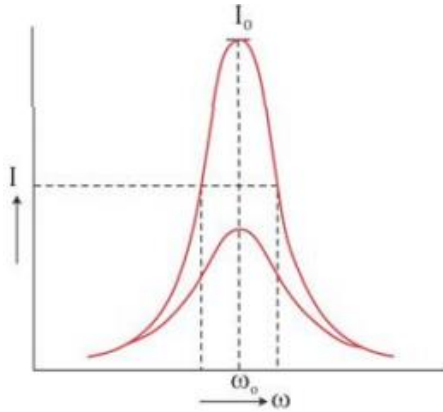

Such an LCR circuit connected in series admits maximum current corresponding to a given frequency of a.c. This frequency is known as series resonance frequency.

At resonant frequency  $\omega_0$ , the impedance of the LCR circuit is minimum, and hence, the current becomes maximum.

For frequencies greater than or less than  $\omega_0$ , the values of current are less than the maximum current value  $I_0$ . As a series resonance circuit admits maximum peak current through it at resonance, it is called an acceptor circuit. Such circuits find application in radios, TV receiver sets etc.

15. The current density  $j$  is related to electric field as

$$E = \sigma E$$

Here,  $\sigma$  is the conductivity of the material.

The above relation is equivalent to Ohm's law.

Now, for a given material,  $\sigma$  is a constant.

Hence, the plot of  $j$  versus  $E$  will be a straight line starting from the origin.

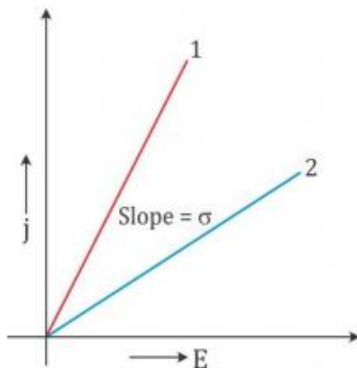

The slope of the graph gives the conductivity  $\sigma$  of the material.

The graph with a greater slope is a better conductor and the graph with a lesser slope is a poor conductor than the other.

(i) To make a standard resistance: A resistor should allow only a limited current to flow through it. Hence, from the graph, we come to know that the material whose plot is similar to plot (2) should be used to make a resistor.



(ii) To make a connecting wire: A wire should allow all the current to flow through it without resisting it. So, it should have a higher conductivity. Hence, from the graph, we come to know that the material whose plot is similar to plot (1) should be used to make a wire.

Electron drift is estimated to be of the order of  $\text{mm s}^{-1}$ . However, the current set up in the wires is of the order of few amperes. This is because the electron density is very large in a material. It is of the order  $10^{28}/\text{m}^3$  of the wire. Hence, all these electrons contribute to the total current. Therefore, despite having small drift speeds, the current set up in wires is large.

16. According to Biot–Savart’s law, the magnitude of the magnetic field  $dB$  is proportional to the current  $I$  and the element length  $dl$ , and inversely proportional to the square of the distance  $r$ .

$$dB \propto \frac{dl \times r}{r^3}$$

$$dB = \frac{\mu_0}{4\pi} \frac{dl \times r}{r^3}$$

Here,  $\frac{\mu_0}{4\pi}$  is a constant of proportionality

The magnitude of this field is given as

$$|dB| = \frac{\mu_0}{4\pi} \frac{I dl \sin \theta}{r^2}$$

Magnetic field on the axis of a circular current loop:

Consider a circular loop carrying a steady current  $I$ . The loop is placed in the  $y$ - $z$  plane with its centre at origin  $O$  and has a radius  $R$ .

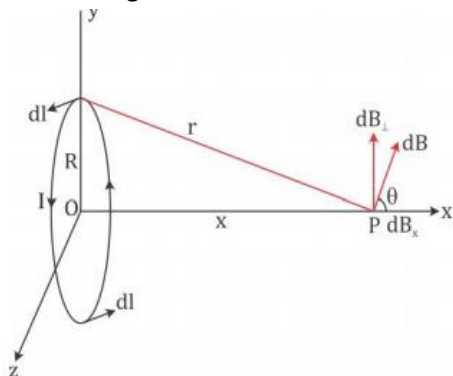

Let  $x$  be the distance of point  $P$  from the centre of the loop where the magnetic field is to be calculated. Consider a conducting element  $dl$  of the loop. The magnitude  $dB$  of the magnetic field due to  $dl$  is given by the Biot–Savart’s law as

$$dB = \frac{\mu_0}{4\pi} \frac{I |dl \times r|}{r^3}$$

From the figure, we see that  $r^2 = x^2 + R^2$ .

Any element of the loop will be perpendicular to the displacement vector from the element to the axial point. Hence, we have  $|dl \times r| = r dl$ . Thus, we have

$$dB = \frac{\mu_0 Idl}{4\pi r^2} = \frac{\mu_0 Idl}{4\pi (x^2 + R^2)} \dots(1)$$

The direction of dB is perpendicular to the plane formed by dl and r. It has an x-component dB<sub>x</sub> and a component perpendicular to x-axis dB<sub>⊥</sub>.

The perpendicular components cancel each other when summed over. Therefore, only the x-component contributes. The net contribution is obtained by integrating dB<sub>x</sub> = dB cosθ

From the figure, we see that

The summation of dl yields circumference of the loop 2πR. Hence, the magnetic field at point P caused by the entire loop is

From equations (1) and (2), we get

$$dB_x = dB \cos \theta = \frac{\mu_0 Idl}{4\pi (x^2 + R^2)} \times \frac{R}{\sqrt{x^2 + R^2}} = \frac{\mu_0 Idl}{4\pi} \times \frac{R}{(x^2 + R^2)^{3/2}}$$

The summation of dl yields circumference of the loop 2πR. Hence, the magnetic field at point P caused by the entire loop is

$$B = B_x \hat{i} = \frac{\mu_0 I(2\pi R)}{4\pi} \times \frac{R}{(x^2 + R^2)^{3/2}} \hat{i}$$

$$B = \frac{\mu_0 IR^2}{2(x^2 + R^2)^{3/2}} \hat{i}$$

Case: At the centre of the loop

At the centre x = 0, so we have

$$B = \frac{\mu_0 IR^2}{2(R^2)^{3/2}} \hat{i} = \frac{\mu_0 IR^2}{2R^3} \hat{i} = \frac{\mu_0 I}{2R} \hat{i}$$

17. A polaroid consists of long-chain molecules aligned in a particular direction.

To show light waves are transverse in nature:

Take two polaroids T<sub>1</sub> and T<sub>2</sub> cut with their faces parallel to the axis of the crystal.

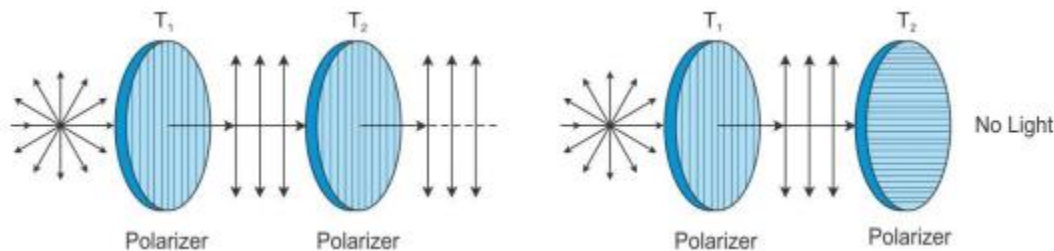

When polaroid T<sub>1</sub> is rotated about the direction of the propagation of light as axis, the intensity of the transmitted light remains the same. When T<sub>2</sub> is rotated gradually, the intensity goes on decreasing and the transmitted light disappears completely when T<sub>2</sub> is perpendicular to T<sub>1</sub>. This happens because the polaroid allows only those vibrations of light which are parallel to its axis. This is true only if light has vibrations in all possible directions and hence is a transverse wave

Light waves are transverse waves. So, they have electric vectors in all possible directions. When a polaroid is placed in between the path of the light, the electric vectors which are parallel to the pass-axis of the polaroid pass through it. Even if the polaroid is rotated, there would be other electric vectors which pass through it. So, the intensity of light does not change irrespective of the orientation of pass-axis of the polaroid.

18. A Zener diode is fabricated by heavily doping both p and n sides of the junction. Because of heavy doping, a very thin ( $<10^{-6}\text{m}$ ) depletion region is formed between the p and n sides, and hence, the electric field of the junction is extremely high ( $\sim 5 \times 10^6 \text{V/m}$ ) even for a small reverse bias voltage of about 5V.

Zener diode as a voltage regulator:

To get a constant d.c. voltage from the d.c. unregulated output of a rectifier, we use a Zener diode. The circuit diagram of a voltage regulator using a Zener diode is shown in the figure below

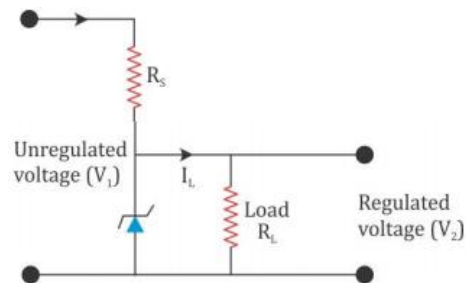

The unregulated d.c. voltage is connected to the Zener diode through a series resistance  $R_s$  such that the Zener diode is reverse biased. If the input voltage increases, the current through  $R_s$  and the Zener diode also increases. This increases the voltage drop across  $R_s$  without any change in the voltage across the Zener diode. This is because the Zener voltage remains constant in the breakdown region even though the current through it changes.

Similarly, if the input voltage decreases, the current through  $R_s$  and the Zener diode also decreases. The voltage drop across  $R_s$  decreases without any change in the voltage across the Zener diode. Thus, any increase or decrease in the input voltage results in an increase or decrease of the voltage drop across  $R_s$  without any change in the voltage across the Zener diode. Hence, the Zener diode acts as a voltage regulator.

**OR**

(a) We know that in an n-type semiconductor, the concentration of electrons is more compared to the concentration of holes. Similarly, in a p-type semiconductor, the concentration of holes is more than the concentration of electrons.

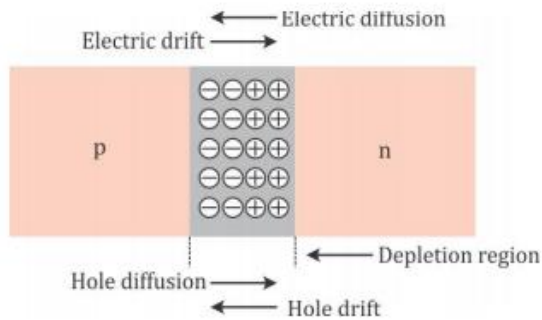

During the formation of a p–n junction and because of the concentration gradient across the p and n sides, holes diffuse from the p-side to the n-side ( $p \rightarrow n$ ) and electrons diffuse from the n-side to the p-side ( $n \rightarrow p$ ). This motion of charge gives rise to a diffusion current across the junction. When an electron diffuses from  $n \rightarrow p$ , it leaves behind an ionised donor on the n-side. This ionised donor (positive charge) is immobile as it is bonded to the surrounding atoms. As the electrons continue to diffuse from  $n \rightarrow p$ , a layer of positive charge (or positive space–charge region) on nside of the junction is developed. Similarly, when a hole diffuses from  $p \rightarrow n$  due to the concentration gradient, it leaves behind an ionised acceptor (negative charge) which is immobile. As the holes continue to diffuse, a layer of negative charge (or negative space–charge region) on the p-side of the junction is developed. This space–charge region on either side of the junction together is known as the depletion region

Because of the positive space–charge region on the n-side of the junction and negative space charge region on the p-side of the junction, an electric field directed from the positive charge towards the negative charge develops. Due to this field, an electron on the p-side of the junction moves to the n-side and a hole on the n-side of the junction moves to the p-side. The loss of electrons from the n-region and the gain of electrons by the p-region cause a difference of potential across the junction of the two regions. This is how the barrier potential is formed.

(b)

(i) If a small voltage is applied to a p–n junction diode in the forward bias, then the barrier potential decreases.

(ii) If a small voltage is applied to a p–n junction diode in the reverse bias, then the barrier potential increases.

19. The ranges of electromagnetic waves are given below:

(a)  $\gamma$ -rays =  $<10^{-3}$  nm

(b) Microwaves = 0.1 m to 1 mm

(c) x-rays = 1 nm to  $10^{-3}$  nm

(d) Radio waves =  $>0.1$  m

Electromagnetic waves in the order of their increasing wavelength are

(a)  $\gamma$ -rays

(b) x-rays

(c) Microwaves

(d) Radio waves

Infrared waves are adjacent to the low frequency or long-wavelength end of the visible spectrum. They are produced by hot bodies and molecules.

Visible light from the atmosphere is absorbed by the Earth's surface and radiated as infrared radiation which gets trapped by greenhouse gases such as carbon dioxide and water vapour.

This is how infrared radiation also plays an important role in maintaining the Earth's warmth.

The molecules of CO<sub>2</sub>, NH<sub>3</sub> and water which are present in most materials absorb infrared waves. Due to this, the molecules heat and heat their surroundings. Hence, their thermal motion increases. Medical instruments, such as the infrared lamp which is used in physiotherapy, work on this principle.

20.

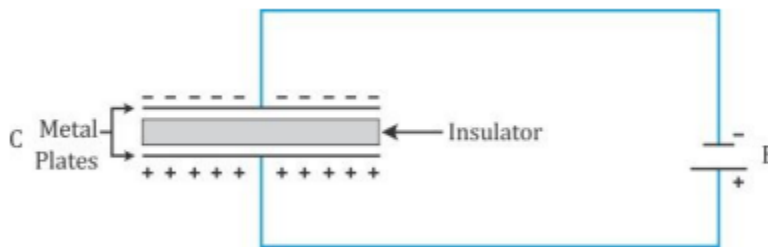

Consider a parallel plate capacitor connected across a d.c. battery as shown in the figure. The electric current will flow through the circuit. As the charges reach the plate, the insulating gap does not allow the charges to move further; hence, positive charges get deposited on one side of the plate and negative charges get deposited on the other side of the plate. As the voltage begins to develop, the electric charge begins to resist the deposition of further charge. Thus, the current flowing through the circuit gradually becomes less and then zero till the voltage of the capacitor is exactly equal but opposite to the voltage of the battery. This is how the capacitor gets charged when it is connected across a d.c. battery.

(a) The electric field between the plates is

$$E = \frac{V}{d}$$

The distance between plates is doubled,  $d' = 2d$

$$E' = \frac{V'}{d'} = \left(\frac{V}{K}\right) \times \frac{1}{2d} = \frac{1}{2} \left(\frac{E}{K}\right)$$

Therefore, if the distance between the plates is double, the electric field will reduce to one half.

(b) As the capacitance of the capacitor,

$$C' = \frac{\epsilon_0 KA}{d'} = \frac{\epsilon_0 KA}{2d} = \frac{1}{2} C$$

Energy stored in the capacitor is  $U = \frac{Q^2}{2C}$  ....(1)

$$U = \frac{Q^2}{2C'} = \frac{Q^2}{2(1/2)C} = 2\left(\frac{Q^2}{2C}\right)2U \quad \text{(from 1)}$$

Therefore, when the distance between the plates is doubled, the capacitance reduces to half.

Therefore, energy stored in the capacitor becomes double

21. In  $\beta^+$  decay, the atomic number Z of the nucleus goes up by 1

The nuclear  $\beta^+$  decay process of  ${}^{11}_6\text{C}$  is

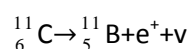

Given

$${}^{11}_6\text{C} = 11.011434 \text{ u}$$

$$m(X) = {}^{11}_5\text{B} = 11.009305 \text{ u}$$

Mass of an electron or positron = 0.000548 u

c = speed of light

The Q value of the nuclear masses of the  ${}^{11}_6\text{C}$  is given as:

$$Q = [m({}^{11}_6\text{C}) - m(m(X)) + m_e]C^2 \quad (1)$$

If atomic masses are used instead of nuclear masses,

then we have to add  $6m_e$  in the case of  ${}^{11}_6\text{C}$  and  $5m_e$  in the case of  ${}^{11}_5\text{B}$

Hence, eq.(1) reduces to

$$Q = [m({}^{11}_6\text{C}) - m({}^{11}_5\text{B}) - 2m_e]C^2$$

$$Q = [11.011434 - 11.009305 - 2 \times 0.000548]C^2$$

$$Q = 0.001033 C^2 \text{ u}$$

$$1 \text{ u} = 931.5 \text{ MeV}/C^2$$

$$Q = 0.001033 \times 931.5 = 0.962 \text{ MeV}$$

22. For a convex lens, we have  $u = -15 \text{ cm}$  and  $f = 10 \text{ cm}$

The mirror formula is

$$\frac{1}{f} = \frac{1}{v} + \frac{1}{u}$$

$$\frac{1}{v} = \frac{1}{f} - \frac{1}{u}$$

$$\frac{1}{v} = \frac{1}{10} + \frac{1}{15}$$

$$v = 6 \text{ cm}$$

The image is smaller in size, virtual and erect. The position of the image is at 6 cm to the right of the mirror

The final image is formed at the position of the object itself when an object lies at the centre of curvature, but the image will be real and inverted in nature. So, the concave mirror should be placed at 20 cm from the pole.

**SECTION- D**

23. (a) If high voltage is used to transmit power, then the current through the wire will be less as  $I = P/V$ . Hence, the power loss  $= I^2R$  will also be less.
- (b) The power is given as  $P = VI \cos\phi$ , where  $\cos\phi$  is the power factor. To supply a given power at a given voltage of transmission, if  $\cos\phi$  is small, then according to the above equation, current  $I$  has to be large. This leads to a large power loss caused by heat which is given as  $H = I^2R$ . Hence, a low power factor implies large power loss.
- (c) Values displayed by Ajit: Understanding in nature and proactive Values displayed by uncle: Patience and intelligence

**SECTION – E**

24. The final image is formed at the position of the object itself when an object lies at the centre of curvature, but the image will be real and inverted in nature. So, the concave mirror should be placed at 20 cm from the pole.

Similarly, the work done in bringing the charge  $q_1$  from infinity to  $r_2$  can be calculated. Here, the work is done not only against the external field  $E$  but also against the field due to  $q_1$ .

Hence, work done on  $q_2$  against the external field is  $W_2 = q_2V(r_2)$ .

Work done on  $q$  against the field due to  $q_1$ ,  $W_{12} = \frac{q_1q_2}{4\pi\epsilon_0 r_{12}}$

where  $r_{12}$  is the distance between  $q_1$  and  $q_2$ .

By the principle of superposition for fields, work done on  $q_2$  against two fields will add with work done in bringing  $q_2$  to  $r_2$ , which is given as

$$W + W = qV(r_2) + \frac{q_1q_2}{4\pi\epsilon_0 r_{12}}$$

Thus, the potential energy of the system  $U =$  total work done in assembling the configuration  $U = W_1 + W_2 + W_{12}$

$$U = qV(r_1) + qV(r_2) + \frac{q_1q_2}{4\pi\epsilon_0 r_{12}}$$

(b)

$$q = +Q$$

$$q = +2Q$$

$$q = -3Q$$

$$r = l \text{ (for each side)}$$

Initial potential energy of system

$$U_1 = \frac{1}{4\pi \epsilon_0 l} [(q_1 \times q_2) + (q_2 \times q_3) + (q_3 \times q_1)]$$

$$U_1 = \frac{1}{4\pi \epsilon_0 l} [(+Q \times +2Q) + (+2Q \times -3Q) + (-3Q \times +Q)]$$

$$U_1 = \frac{-7Q^2}{4\pi \epsilon_0 l}$$

These charges displaced to mid points then final potential energy of system,

$$U_2 = \frac{1}{4\pi \epsilon_0 l/2} [(q_1 \times q_2) + (q_2 \times q_3) + (q_3 \times q_1)]$$

$$U_2 = \frac{2}{4\pi \epsilon_0 l} [(+Q \times +2Q) + (+2Q \times -3Q) + (-3Q \times +Q)]$$

$$U_2 = \frac{-7Q^2}{4\pi \epsilon_0 l}$$

Work done,  $W = U_2 - U_1$

$$W = \frac{-7Q^2}{2\pi \epsilon_0 l} - \frac{-7Q^2}{4\pi \epsilon_0 l}$$

$$W = \frac{-7Q^2}{\pi \epsilon_0 l} \left[ \frac{-1}{2} - \left( \frac{-1}{4} \right) \right] = \frac{7Q^2}{\pi \epsilon_0 l} \left[ \frac{-1}{2} + \frac{1}{4} \right]$$

$$W = \frac{-7}{4} \left( \frac{Q^2}{\pi \epsilon_0 l} \right)$$

**OR**

Electric flux is the total number of lines of force passing through the unit area of a surface held perpendicularly.

Electric flux  $\Delta\phi$  through an area element  $\Delta S$  is given by

$$\Delta\phi = E \cdot \Delta S = E \Delta S \cos \theta$$

$\theta$  is the angle between  $E$  and  $\Delta S$ .

The SI unit of electric flux is  $N C^{-1} m^2$

Gauss's law states that the flux of the electric field through any closed surface  $S$  is  $1/\epsilon_0$  times the total charge enclosed by  $S$ .

Let the total flux through a sphere of radius  $r$  enclose a point charge  $q$  at its centre. Divide the sphere into a small area element as shown in the figure.



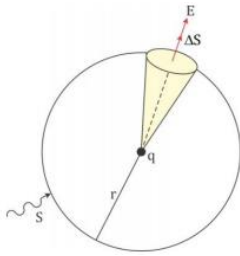

The flux through an area element  $\Delta S$  is

$$\Delta\Phi = E\Delta S = \frac{q}{4\pi\epsilon_0 r^2} \hat{r} \cdot \Delta S$$

Here, we have used Coulomb's law for the electric field due to a single charge  $q$ .

The unit vector  $\hat{r}$  is along the radius vector from the centre to the area element. Because the normal to a sphere at every point is along the radius vector at that point, the area element  $\Delta S$  and  $\hat{r}$  have the same direction. Therefore,

$$\Delta\Phi = \frac{q}{4\pi\epsilon_0 r^2} \cdot \Delta S$$

Because the magnitude of the unit vector is 1, the total flux through the sphere is obtained by adding the flux through all the different area elements.

$$\Phi = \sum_{all\ \Delta S} = \frac{q}{4\pi\epsilon_0 r^2} \cdot \Delta S$$

Because each area element of the sphere is at the same distance  $r$  from the charge,

$$\Phi = \frac{q}{4\pi\epsilon_0 r^2} \sum_{all\ \Delta S} = \frac{q}{4\pi\epsilon_0 r^2} \cdot S$$

Now,  $S$  the total area of the sphere equals  $4\pi r^2$ . Thus

$$\Phi = \frac{q}{4\pi\epsilon_0 r^2} \cdot 4\pi r^2 = \frac{q}{\epsilon_0}$$

Hence, the above equation is a simple illustration of a general result of electrostatics called Gauss's law.

Let a cube of side  $a$  enclose charge  $+q$  at its centre.

Because the electric flux through the square surface is  $\Phi = \frac{q}{6\epsilon_0}$

the square surfaces of cube are six. Hence, according to Gauss's theorem in electrostatics, the total outward flux due to a charge  $+q$  of a cube is

$$\Phi = 6 \times \left( \frac{q}{6\epsilon_0} \right) = \frac{q}{\epsilon_0}$$

The result shows that the electric flux passing through a closed surface is proportional to the charge enclosed. In addition, the result reinforces that the flux is independent of the shape and size of the closed surface.

25. (a) Self-inductance of a coil is defined as the ratio of the total flux linked with the coil to the current flowing through it

$$L = \frac{N\Phi_B}{I}$$

When the current is varied, the flux linked with the coil changes and an e.m.f. is induced in the coil. It is given as

$$\varepsilon = -\frac{d(N\Phi_B)}{dt} = -L\frac{dI}{dt}$$

The self-induced e.m.f. is also called back e.m.f. as it opposes any change in current in the circuit. So, work needs to be done against back e.m.f. in establishing current. This work done is stored as magnetic potential energy. The rate of doing work is given as

$$\frac{dW}{dt} = |\varepsilon| I = LI \frac{dI}{dt} \quad (\text{neglecting negative sign})$$

Thus, the total work done in establishing current from 0 to I is

$$w = \int dW = \int_0^I LI dI = \frac{1}{2} LI^2$$

(b)

(i) The direction of induced current in the loop as it goes out is depicted in the figure below

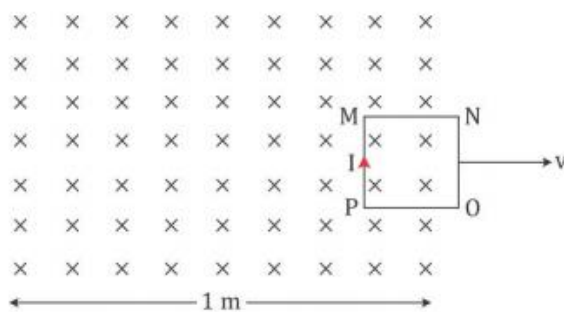

The current will persist till the entire loop comes out of the field.

Hence, we have

$$t = \frac{d}{v} = \frac{20\text{cm}}{20\text{cm/s}} = 1\text{s}$$

Hence, the current will persist for 1 second.

(ii) The magnetic flux in the coil when it is inside the field is constant. This maximum flux is given as  $\phi = Bla$  ( $a$  is the side of the square loop). This flux will start dropping once the loop comes out of the field and will be zero when it is completely out of the field.

The e.m.f. induced in the coil when it is inside the field is zero as the flux is not changing. When the loop just comes out of the field, the flux change is maximum

and the e.m.f. induced is  $e = -\frac{d\Phi}{dt} = -Bl \frac{db}{dt} = -Blv$ . This e.m.f remains constant till the entire loop comes out. When the loop is completely out of the field, the e.m.f. drops to zero again

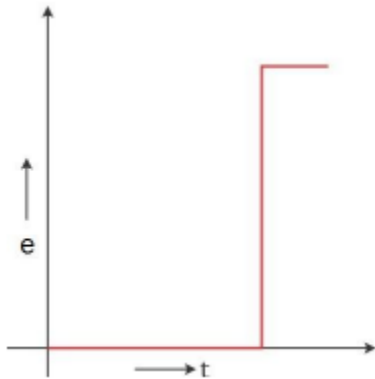
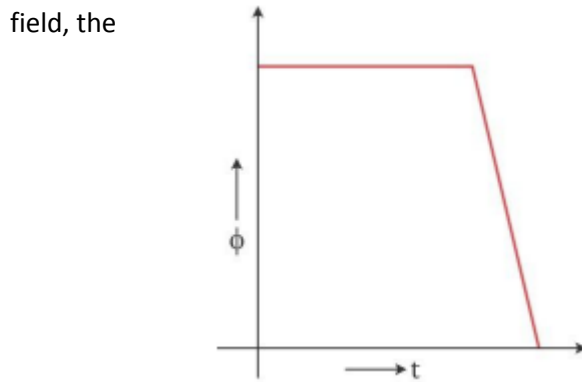

OR

(a) When a circular loop of area  $A$  carries a current  $I$ , the loop creates a magnetic field around it. The strength of the magnetic field created depends on the current through the conductor. At the centre of the loop, the magnetic field lines are perpendicular to the plane of the loop which provides the magnetic moment,  $m = IA$ . Hence, it behaves like a magnet. The comparison between the magnetic field lines around a current-carrying loop and a bar magnet shows that the two patterns are similar.

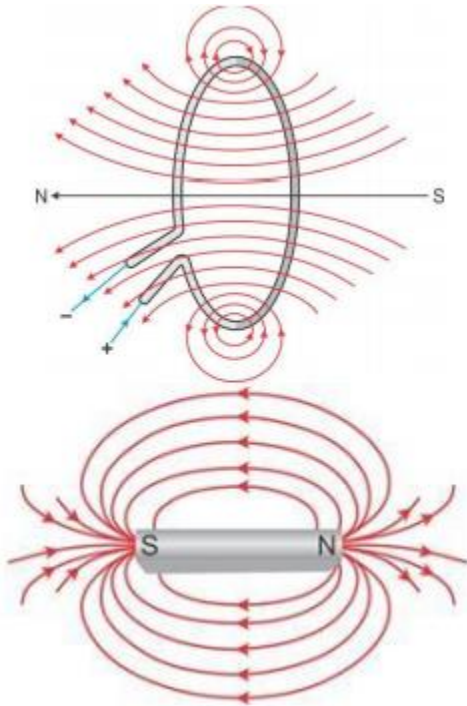

If the current in the loop is in the anticlockwise direction, a North Pole is formed and if the current is in the clockwise direction, a South Pole is formed.

(b) Consider a solenoid of length  $2l$ , radius  $a$  and having  $n$  turns per unit length. It is carrying a current  $I$ .

We have to evaluate the axial field at a point  $P$  at a distance  $r$  from the centre of the solenoid.

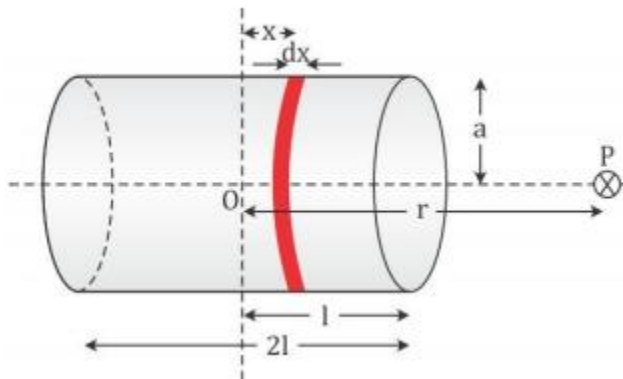

Consider a circular element of thickness  $dx$  of the solenoid at a distance  $x$  from its centre

The magnitude of the field due to this circular loop carrying a current  $I$  is given as

$$dB = \frac{\mu_0 dx n l a^2}{2[(r-x)^2 + a^2]^{3/2}}$$

The magnitude of the total field is obtained by integrating over all the elements from

$x = -l$  to  $x = +l$ .

$$B = \frac{\mu_0 n l a^2}{2} \int_{-l}^{+l} \frac{dx}{2[(r-x)^2 + a^2]^{3/2}}$$

Consider the far axial field of the solenoid, so  $r \gg a$  and  $r \gg l$ . Hence, we have

$$[(r-x)^2 + a^2]^{3/2} \approx r^3$$

So, we get

$$B = \frac{\mu_0 n l a^2}{2r^3} \int_{-l}^{+l} dx$$

$$B = \frac{\mu_0 n l a^2}{2r^3} 2l$$

The magnitude of the magnetic moment of the solenoid is

$m$  Total number of turns current cross-sectional area

$$m = (n \times 2l) \times I \times (\pi a^2)$$

Therefore, we get the magnetic field as

$$B = \frac{\mu_0}{4\pi} \frac{2m}{r^3}$$

This is the expression for magnetic field due to a solenoid on the axial line at a distance  $r$  from the centre.

This magnetic field is also the field due to a bar magnet of magnetic moment  $m$ .

26. (a) Young's double slit experiment demonstrated the phenomenon of interference of light.

Consider two fine slits  $S_1$  and  $S_2$  at a small distance  $d$  apart. Let the slits be illuminated by a monochromatic source of light of wavelength  $\lambda$ . Let  $GG'$  be a screen kept at a distance  $D$  from the slits. The two waves emanating from slits  $S_1$  and  $S_2$  superimpose on each other resulting in the formation of an interference pattern on the screen placed parallel to the slits.

Let  $O$  be the centre of the distance between the slits. The intensity of light at a point on the screen will depend on the path difference between the two waves reaching that point. Consider an arbitrary point  $P$  at a distance  $x$  from  $O$  on the screen.

Path difference between two waves at  $P = S_2P - S_1P$

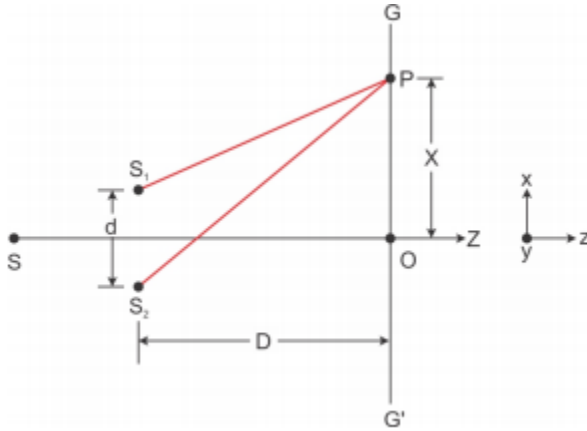

The intensity at the point P is maximum or minimum as the path difference is an integral multiple of wavelength or an odd integral multiple of half wavelength. For the point P to correspond to maxima, we must have

$$S_2P - S_1P = n\lambda, n = 0, 1, 2, 3, \dots$$

From the figure given above,

$$(S_2P)^2 - (S_1P)^2 = D^2 + \left(x + \frac{d}{2}\right)^2 - D^2 + \left(x - \frac{d}{2}\right)^2$$

On solving we get

$$(S_2P)^2 - (S_1P)^2 = 2xd$$

$$S_2P - S_1P = \frac{2xd}{S_2P + S_1P}$$

As  $d \ll D$ , then  $S_2P + S_1P = 2D$  ( $\because S_1P = S_2P \cong D$ )

$$\therefore S_2P - S_1P = \frac{2xd}{2D} = \frac{xd}{D}$$

$$\text{Path difference, } S_2P - S_1P = \frac{xd}{D}$$

Hence, when constructive interference occurs, bright region is formed.

$$\text{For maxima or bright fringe, path difference} = \frac{xd}{D} = n\lambda$$

$$\text{i.e. } x = \frac{n\lambda D}{d}$$

where  $n=0, \pm 1, \pm 2, \dots$

During destructive interference dark fringes are formed:

$$\text{Path difference, } \frac{xd}{D} = \left(n + \frac{1}{2}\right)\lambda$$

$$x = \left(n + \frac{1}{2}\right)\frac{\lambda D}{d}$$

The dark fringe and the bright fringe are equally spaced and the distance between consecutive bright and dark fringe is given by:

$$\beta = x_{n+1} - x_n$$

$$\beta = \frac{(n+1)\lambda D}{d} - \frac{n\lambda D}{d}$$

$$\beta = \frac{\lambda D}{d}$$

Hence the fringe width is given by  $\beta = \frac{\lambda D}{d}$

(b) The intensity variation in the fringe pattern obtained on a screen in a Young's double slit experiment corresponds to both single slit diffraction and double slit interference because the two sources are slits of finite width in the double slit experiment.

If a lens is placed in front of the double slits and when one of the slit S1 is closed and the other kept open, a single slit diffraction is formed on the screen. A similar diffraction pattern is obtained on the screen if the slit S1 is kept open and S2 is closed. Both diffraction patterns form on the same position on the screen in the focal plane of the lens. When both slits open simultaneously, the resulting total intensity pattern on the screen is actually the superposition of the single slit diffraction pattern formed by waves from various point sources of each slit and a double slit interference pattern as shown. The actual double slit intensity pattern consists of the interference pattern (solid lines) formed within the diffraction pattern (dotted lines).

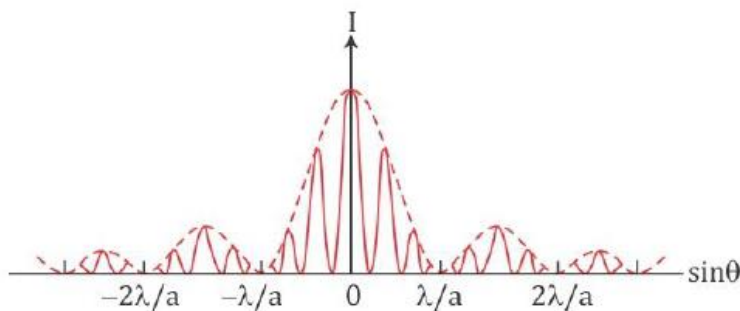

(c) Let the width of each slit be 'a'.

The separation between m maxima in a double slit experiment is given by  $y_m$

$$y_m = m \frac{\lambda D}{d}$$

where D is the distance between the screen and the slit and d is the separation between the slits.

We know that the angular separation between m maxima can be given as

$$\theta_m = \frac{y_m}{D} = \frac{m \frac{\lambda D}{d}}{D}$$

$$\Rightarrow \theta_m = \frac{m\lambda}{d}$$

Therefore, we can write the angular separation between 10 bright fringes as

$$\Rightarrow \theta_{10} = \frac{10\lambda}{d} \text{----- (1)}$$

The angular width of the central maximum in the diffraction pattern due to a single slit of width 'a' is given by

$$2\theta_1 = 2\left(\frac{\lambda}{a}\right) \text{----- (2)}$$

It is given that 10 maxima of the double slit pattern is formed within the central maximum of the single slit pattern.

Therefore, we can equate (1) and (2) as

$$\frac{10\lambda}{d} = \frac{2\lambda}{a}$$

solving, we get

$$a = \frac{2\lambda d}{10\lambda}$$

$$a = \frac{d}{5}$$

Given that the separation between the slits = 1 mm

$$\text{Therefore the slit width } a = \frac{d}{5} = \frac{1\text{mm}}{5} = 0.2\text{mm}$$

Therefore, the width of each slit = 0.2 mm

**OR**

(a) Consider two thin lens L1 and L2 of focal length f1 and f2 held coaxially in contact with each other. Let P be the point where the optical centres of the lenses coincide (lenses being thin).

Let the object be placed at a point O beyond the focus of lens L1 such that OP = u (object distance). Lens L1 alone forms the image at I1 where P I1 = v1 (image distance). The image I1 would serve as a virtual object for lens L2 which forms a final image I at distance PI = v. The ray diagram showing the image formation by the combination of these two thin convex lenses will be as shown below:



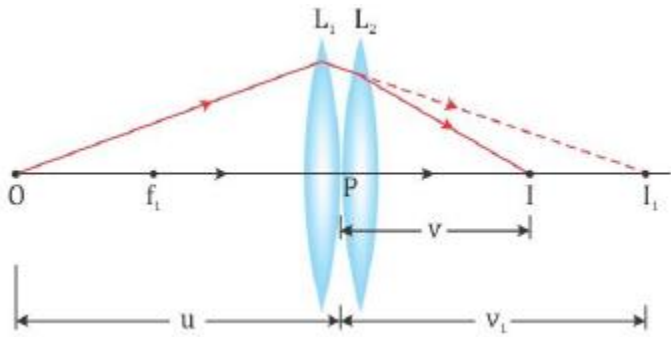

From the lens formula, for the image I1 formed by the lens L1, we have

$$\frac{1}{v_1} - \frac{1}{u} = \frac{1}{f_1} \text{-----(1)}$$

for the image formation by the second lens, L2

$$\frac{1}{v} - \frac{1}{v_1} = \frac{1}{f_2} \text{-----(2)}$$

Adding (1) and (2) we get :

$$\frac{1}{v_1} + \frac{1}{u} = \frac{1}{v} + \frac{1}{v} - \frac{1}{v_1} = \frac{1}{v} + \frac{1}{f_2}$$

$$-\frac{1}{u} + \frac{1}{v} = \frac{1}{f_1} + \frac{1}{f_2}$$

$$\frac{1}{v} - \frac{1}{u} = \frac{1}{f_1} + \frac{1}{f_2}$$

If the two lenses are considered a single lens of focal length f, which forms an image I at a distance v with an object distance being u, then we get

$$\frac{1}{v} - \frac{1}{u} = \frac{1}{f} \quad \left( \text{where, } \frac{1}{f} = \frac{1}{f_1} + \frac{1}{f_2} \right)$$

$$\Rightarrow f = \frac{f_1 f_2}{f_1 + f_2}$$

Hence, the focal length of the combined system is given by  $f = \frac{f_1 f_2}{f_1 + f_2}$

(b) Given that side AQ = AR. This implies that  $\angle AQR = \angle ARQ$

The ray diagram for the refraction of ray PQ passing through the prism ABC is as shown below.

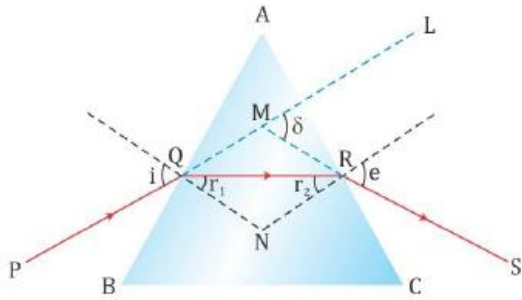

As the ray PQ after refraction from surface AB emerges from face AC at point R of the prism, it implies that the refracted ray QR travels parallel to the base of the prism. This happens at the minimum deviation position.

So, according to the angle of minimum deviation formula, we have

$$\mu = \frac{\sin\left(\frac{A + \delta_m}{2}\right)}{\sin\frac{A}{2}} \text{-----(1)}$$

Where A is the angle of prism,  $\delta_m$  is the angle of minimum deviation and  $\mu$  is the refractive index of the prism.

Given  $A = 60^\circ$ ,  $n = \sqrt{3}$

Substituting in (1) we get:

$$\sqrt{3} = \frac{\sin\left(\frac{60^\circ + \delta_m}{2}\right)}{\sin\frac{60^\circ}{2}}$$

$$\sqrt{3} \times \sin 30^\circ = \sin\left(\frac{60^\circ + \delta_m}{2}\right)$$

$$\frac{\sqrt{3}}{2} = \sin\left(\frac{60^\circ + \delta_m}{2}\right)$$

$$\sin^{-1}\left(\frac{\sqrt{3}}{2}\right) = \frac{60^\circ + \delta_m}{2}$$

$$60^\circ = \frac{60^\circ + \delta_m}{2}$$

$$120^\circ = 60^\circ + \delta_m$$

$$\Rightarrow \delta_m = 60^\circ$$

Thus, the angle of minimum deviation =  $60^\circ$ .

At the minimum deviation position,

$$i = \frac{A + \delta_m}{2}$$

We know  $A = 60^\circ$ ,  $\delta_m = 60^\circ$

Substituting we get:

$$i = \frac{60^0 + 60^0}{2}$$

$$\Rightarrow i = 60^0$$