

CBSE SAMPLE PAPER -2016-17

NAME OF THE UNIT	TOTAL WEIGHTAGE	VSA (1 mark)	SA (2 marks)	SA (3 marks)	VBQ (4marks)	LA (5 marks)	WEIGHTAGE	
Solid State	23	1 (1) Remembering		3 (1) Understanding			4 (2)	
Solutions			2 (1) Remembering	3 (1) Evaluation			5 (2)	
Electrochemistry						5 (1) Application	5 (1)	
Chemical Kinetics				2 (1) Application	3 (1) Application			5 (2)
Surface Chemistry			1 (1) Remembering		3 (1) Evaluation			4 (2)
General Principles and Processes of Isolation of Elements	19			3 (1) Application			3 (1)	
p - Block Elements			2 (1) Understanding	3 (1) Application			5 (2)	
d - and f - Block Elements		1 (1) HOTS				5 (1) Understanding	6 (2)	
Coordination Compounds			2 (1) Application	3 (1) HOTS			5 (2)	
Haloalkanes and Haloarenes	28	1 (1) Evaluation		3 (1) Understanding			4 (2)	
Alcohols, Phenols and Ethers		1 (1) HOTS		3 (1) understanding			4 (2)	
Aldehydes, Ketones and Carboxylic acids						5 (1) HOTS	5 (1)	
Amines			2 (1) Understanding	3 (1) Application			5 (2)	
Biomolecules				3 (1) Remembering			3 (1)	
Polymers				3 (1) Understanding			3 (1)	
Chemistry in Everyday Life						4 (1)* Value based question	4 (1)	
TOTAL		5 (5)	10 (5)	36 (12)	4 (1)	15 (3)	70 (26)	

* Value based question

A(B) WHERE; A = NUMBER OF QUESTIONS; B= MARKS

HENCE 26 (70)

Sample Question Paper Chemistry class XII 2016-17

MM:70

TIME 3 HRS

1.	Define Kraft temperature.	1
2.	The electronic configuration of a transition element in +3 oxidation state is $[\text{Ar}]3d^7$. Find out its atomic number.	1
3.	Draw the structure of 4-tertbutyl-3-iodoheptane.	1
4.	Give the equation of reaction for the preparation of phenol from cumene.	1
5.	Name the type of semiconductor obtained when silicon is doped with boron.	1
6.	The two complexes of nickel, $[\text{Ni}(\text{CN})_4]^{2-}$ and $[\text{Ni}(\text{CO})_4]$, have different structures but possess same magnetic behaviour. Explain. OR A chloride of fourth group cation in qualitative analysis gives a green coloured complex [A] in aqueous solution which when treated with ethane -1, 2 - diamine (en) gives pale - yellow solution [B] which on subsequent addition of ethane -1, 2 - diamine turns to blue/purple [C] and finally to violet [D]. Write the structures of complexes [A], [B], [C] and [D].	2
7.	Account for the following : (i) XeF_2 is linear molecule without a bend. The electron gain enthalpy with negative sign for fluorine is less than that of chlorine, still fluorine is a stronger oxidizing agent than chlorine.	2
8.	Derive the relationship between relative lowering of vapour pressure and mole fraction of the volatile liquid.	2
9.	After 24 hrs, only 0.125 gm out of the initial quantity of 1 gm of a radioactive isotope remains behind. What is its half life period?	2
10.	Write the IUPAC names of the following: $\text{C}_6\text{H}_5\text{CH}_2\text{NH}_2$, $\text{CH}_3-\text{N} \begin{matrix} \diagup \text{CH}_3 \\ \diagdown \text{CH}_3 \end{matrix}$	2
11.	The edge length of a unit cell of a metal having molecular mass 75 g/mol is 5 \AA which crystallises in a cubic lattice. If the density is 2g/cc, then find the radius of the metal atom.	3
12.	(i) A mixture of X and Y was loaded in the column of silica. It was eluted by alcohol water mixture. Compound Y eluted in preference to compound X. Compare the extent of adsorption of X and Y on column. (ii) Why copper matte is put in silica lined converter? Write reactions involved (iii) Name the method used for the refining of Zr.	3

13.	(i) Complete the following chemical equations. (a) $\text{NH}_4\text{Cl}(\text{aq.}) + \text{NaNO}_2(\text{aq.}) \rightarrow$ (b) $\text{P}_4 + 3\text{NaOH} + 3\text{H}_2\text{O} \rightarrow$ (ii) Why is $K_{a2} \ll K_{a1}$ for H_2SO_4 in water?	3
14.	Write the correct formulae for the following coordination compounds: (i) $\text{CrCl}_3 \cdot 6\text{H}_2\text{O}$ (violet with 3 chloride ions precipitated as AgCl) (ii) $\text{CrCl}_3 \cdot 6\text{H}_2\text{O}$ (light green colour, with 2 chloride ions precipitated as AgCl) (iii) $\text{CrCl}_3 \cdot 6\text{H}_2\text{O}$ (dark green colour, with 1 chloride ion precipitated as AgCl)	3
15.	Give reasons for the following observations: (i) p-dichlorobenzene has higher melting point than those of o and m –isomers. (ii) Haloarenes are less reactive than haloalkanes towards nucleophilic substitution reaction. (iii) The treatment of alkyl chloride with aqueous KOH leads to the formation of alcohol but in the presence of alcoholic KOH , alkene is the major product,	3
16.	(i) Why does leather get hardened after tanning? (ii) On the basis of Hardy-Schulze rule explain why the coagulating power of phosphate is higher than chloride. (iii) Do the vital functions of the body such as digestion get affected during fever? Explain your answer.	3
17.	Calculate the mass of a non-volatile solute (molar mass 40 g/mol) which should be dissolved in 114 g octane to reduce its vapour pressure to 80%. OR At 300 K, 36 g of glucose, $\text{C}_6\text{H}_{12}\text{O}_6$ present per litre in its solution has an osmotic pressure of 4.98 bar. If the osmotic pressure of another glucose solution is 1.52 bar at the same temperature, calculate the concentration of the other solution.	3
18.	Carry out the following conversions : i) Phenol to benzoquinone. ii) Propanone to 2-Methylpropan-2-ol. iii) Propene to propan-2-ol.	3
19.	(i) Illustrate the following reactions: a) Hoffmann bromamide degradation reaction. b) Coupling reaction. (ii) Write a chemical test to distinguish between aniline and methylamine.	3
20.	(i) Name the common types of secondary structure of proteins and give one point of difference. (ii) Give one structural difference between amylose and amylopectin	3
21.	Observe the graph in diagram and answer the following questions.	3

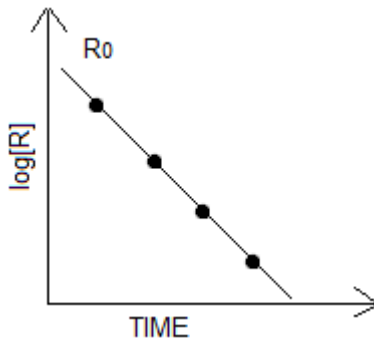
	 <p>(i) If slope is equal to $-2.0 \times 10^{-6} \text{ sec}^{-1}$, what will be the value of rate constant? (ii) How does the half-life of zero order reaction relate to its rate constant?</p>	
22.	<p>(i) Classify the following as addition and condensation polymers: Terylene, Bakelite, Polyvinyl chloride, Polythene. (ii) Explain the difference between Buna – N and Buna – S.</p>	3
23.	<p>Ali's brother likes taking medicines. He sometimes even takes cough syrups even when he is not ill. One such day, he took cough syrup when he was healthy. After some time he started feeling nausea, headache and his body started itching. Ali's father did not take him to the doctor and wanted to give medicine on his own. Ali insisted that his father should not give medicine to his brother on his own but should take him to a doctor.</p> <p>After reading the above passage, answer the following questions: (i) Mention the values shown by Ali. (ii) Why did his body start itching and what kind of medicine will doctor prescribe him? (iii) Why medicines should not be taken without consulting doctor? (iv) Give one point of difference between agonist and antagonist.</p>	4
24.	<p>(i) State the relationship amongst cell constant of a cell, resistance of the solution in the cell and conductivity of the solution. How is molar conductivity of a solution related to conductivity of its solution? (ii) A voltaic cell is set up at 25°C with the following half cell; Al / Al³⁺ (0.001 M) and Ni / Ni²⁺ (0.50 M) Calculate the cell voltage. [$E^\circ_{\text{Ni}^{2+}/\text{Ni}} = -0.25\text{V}$, $E^\circ_{\text{Al}^{3+}/\text{Al}} = -1.66\text{V}$]</p> <p style="text-align: center;">OR</p> <p>(i) Calculate the potential of hydrogen electrode in contact with a solution whose pH is 10. (ii) State Faraday's laws of electrolysis. How much charge in terms of Faraday is required for reduction of 1 mol of Cr₂O₇²⁻ to Cr³⁺ ?</p>	5
25.	<p>(i) Is the variability in oxidation number of transition elements different from that of non – transition elements? Illustrate with examples. (ii) Give reasons: (a) d- block elements exhibit more oxidation states than f-block elements. (b) Orange solution of potassium dichromate turns yellow on adding sodium hydroxide to it. (c) Zirconium (Z= 40) and Hafnium (Z = 72) have almost similar atomic radii.</p>	5

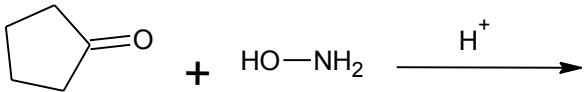
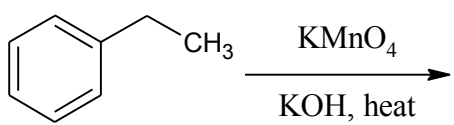
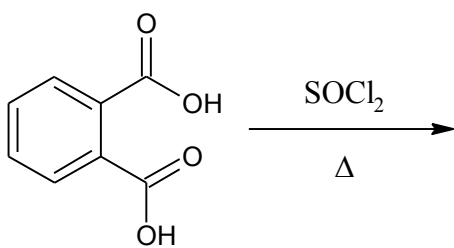
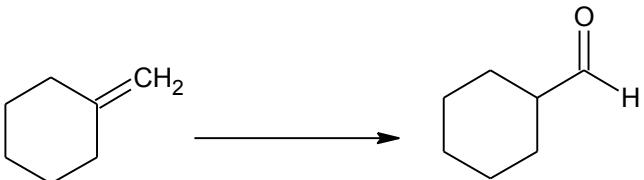
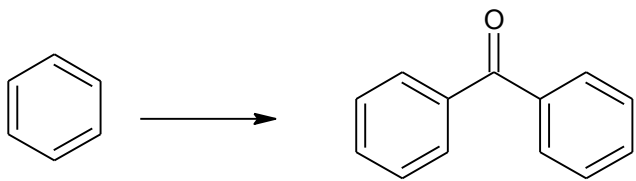
	OR	
	<p>(i) Describe the preparation of potassium permanganate from pyrolusite ore. Write balanced chemical equation for one reaction to show the oxidizing nature of potassium permanganate.</p> <p>(ii) Draw the structures of chromate and dichromate ions.</p>	
26.	<p>(i) A ketone A which undergoes haloform reaction gives compound B on reduction. B on heating with sulphuric acid gives compound C, which forms mono-ozonide D. The compound D on hydrolysis in presence of zinc dust gives only acetaldehyde. Write the structures and IUPAC names of A, B and C. Write down the reactions involved.</p> <p>(ii) Predict the products formed when cyclohexanecarbaldehyde reacts with following reagents.</p> <p>(a) PhMgBr and then H_3O^+.</p> <p>(b) Tollens' reagent.</p>	5
	OR	
	<p>(i) Complete each synthesis by giving missing starting material, reagent or products:</p> <p>(a) </p> <p>(b) </p> <p>(c) </p> <p>(d) </p> <p>(e) </p>	

MARKING SCHEME

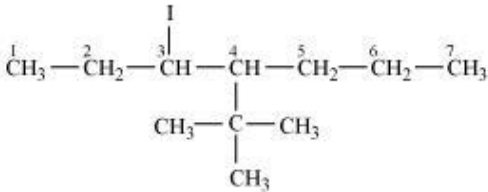
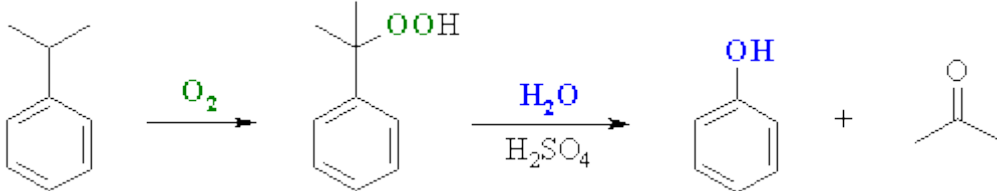
1.	The formation of micelle takes place only above a particular temperature called Kraft temperature.	1
2.	28	1
3.		1
4.		1
5.	P type semiconductor	1
6.	<p>$[\text{Ni}(\text{CN})_4]^{2-}$ dsp^2 hybridisation, Ni in +2 state all electrons are paired, so diamagnetic.</p> <p>$[\text{Ni}(\text{CO})_4]$ sp^3 hybridisation, Ni in 0 state all electrons are paired so diamagnetic</p> <p style="text-align: center;">OR</p> <p>A=$[\text{Ni}(\text{H}_2\text{O})_6]^{2+}$ B=$[\text{Ni}(\text{H}_2\text{O})_4(\text{en})]^{2+}$ C=$[\text{Ni}(\text{H}_2\text{O})_2(\text{en})_2]^{2+}$ D=$[\text{Ni}(\text{en})_3]^{2+}$</p>	$\frac{1}{2}+1/2+$ $1/2+1/2$
7.	<p>(i) The electron arrangement is trigonal bipyramidal. The shape is linear because the lone pairs prefer the equatorial positions. The molecule XeF_2 has 3 lone-pairs and 2 bond-pairs.</p> <p>(ii) Low bond dissociation enthalpy and high hydration enthalpy of fluorine.</p>	1+1
8.	<p>Let us assume a binary solution in which the mole fraction of the solvent be x_1 and that of the solute be x_2, p_1 be the vapour pressure of the solvent and p_1^0 be the vapour pressure of the solvent in pure state.</p> <p>According to Raoult's Law:</p> <p>$p_1 = x_1 p_1^0 \dots \dots \dots (1)$</p>	$\frac{1}{2}$

	<p>The decrease in vapour pressure of the solvent (Δp_1) is given by:</p> $\Rightarrow \Delta p_1 = p_1^\circ - p_1$ $\Rightarrow \Delta p_1 = p_1^\circ - p_1^\circ x_1 \quad \text{[using equation (1)]}$ $\Rightarrow \Delta p_1 = p_1^\circ (1 - x_1)$ <p>Since we have assumed the solution to be binary solution, $x_2 = 1 - x_1$</p> $\Rightarrow \Delta p_1 = p_1^\circ x_2$ $\Rightarrow x_2 = \Delta p_1 / p_1^\circ$	<p>$\frac{1}{2}$</p> <p>$\frac{1}{2}$</p> <p>$\frac{1}{2}$</p>
9.	<p>$a = 1g, a - x = 0.125g, t = 24 \text{ hours}$</p> $k = \frac{2.303}{t} \log \frac{a}{a-x}$ $k = \frac{2.303}{t} \log \frac{1}{0.125}$ $= 0.0866 \text{ hr}^{-1}$ $t_{1/2} = \frac{0.693}{k}$ $t_{1/2} = \frac{0.693}{0.0866}$ $= 8 \text{ hours}$	<p>$\frac{1}{2}$</p> <p>$\frac{1}{2}$</p> <p>$\frac{1}{2}$</p> <p>$\frac{1}{2}$</p>
10.	<p>(i) 1-Phenylmethanamine.</p> <p>(ii) N,N-Dimethylmethanamine.</p>	<p>1</p> <p>1</p>
11.	$\rho = \frac{Z \times M}{a^3 \times N_A}$ $Z = \frac{2 \times (5 \times 10^{-8})^3 \times 6 \times 10^{23}}{75}$ $= 2$ $r = \sqrt{\frac{3}{4}} a$	<p>$\frac{1}{2}$</p> <p>$\frac{1}{2}$</p> <p>1</p> <p>$\frac{1}{2}$</p>

	$r = \sqrt{\frac{3}{4}} \times 5$ $= 2.165A^0$	1/2
12.	(i) X is more strongly adsorbed than Y. (ii) Copper matte contains small amount of FeO as impurity which is removed as FeSiO ₃ slag when reacts with silica. $\text{FeO} + \text{SiO}_2 \rightarrow \text{FeSiO}_3 \text{ (slag)}$ (iii) Van Arkel Method	1 1/2 1/2 1
13.	(a) $\text{NH}_4\text{Cl (aq.)} + \text{NaNO}_2 \text{ (aq.)} \rightarrow \text{N}_2\text{(g)} + 2\text{H}_2\text{O(l)} + \text{NaCl(aq.)}$ (b) $\text{P}_4 + 3\text{NaOH} + 3\text{H}_2\text{O} \rightarrow 3\text{NaH}_2\text{PO}_2 + \text{PH}_3$ (iii) H ₂ SO ₄ is a very strong acid in water because of its first ionisation to H ₃ O ⁺ and HSO ₄ ⁻ . The ionization of HSO ₄ ⁻ to H ₃ O ⁺ and SO ₄ ²⁻ is very small (it is difficult to remove a proton from a negatively charged ion).	1 1 1
14.	(i) [Cr(H ₂ O) ₆]Cl ₃ (ii) [Cr(H ₂ O) ₅ Cl]Cl ₂ H ₂ O (iii) [Cr(H ₂ O) ₄ (Cl) ₂]Cl(H ₂ O) ₂	1 1 1
15.	(i) It is due to the symmetry of para-isomers that fits in the crystal better as compared to ortho and meta-isomers. (ii) Resonance effect / Difference in hybridization of carbon atom in C-X bond / Instability of phenyl cation / because of the repulsion, it is less likely for the electron rich nucleophile to approach electron rich arenes . (iii) Alkoxide ion present in alcoholic KOH, is not only a strong nucleophile but also a strong base.	1 1 1
16.	(i) Animal hides are colloidal in nature, having positively charged particles, when soaked in tannin, which contains negatively charged colloidal particles, mutual coagulation occurs. (ii) Greater the valency of flocculating ion added, greater is its power to cause precipitation. (iii) The optimum temperature range for enzymatic activity is 298-310 K i.e enzymes are active beyond this temp. range, thus during fever the activity of enzymes may be affected.	1 1 1
17	if vapour pressure of pure liquid is = P _o 80 % of pure liquid P _s = 80 × P _o / 100 = 0.8P _o $P_s = P_o \times X_{\text{solute}}$ mass of solute = x gram And mass of solvent = 114g Molar mass of solute = 40 g/mol Molar mass of solvent (octane C ₈ H ₁₈) = 114g/mol Number of moles of solute = x/40 = 0.025x Number of moles of solvent = 114/114 = 1 moles Mole fraction of solvent = 1/(1+0.025x) $0.8P_o = P_o \times 1/(1+0.025x)$ Cross multiply we get $(1+0.025x)0.8P_o = P_o$	1 1/2 1

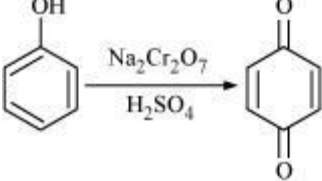
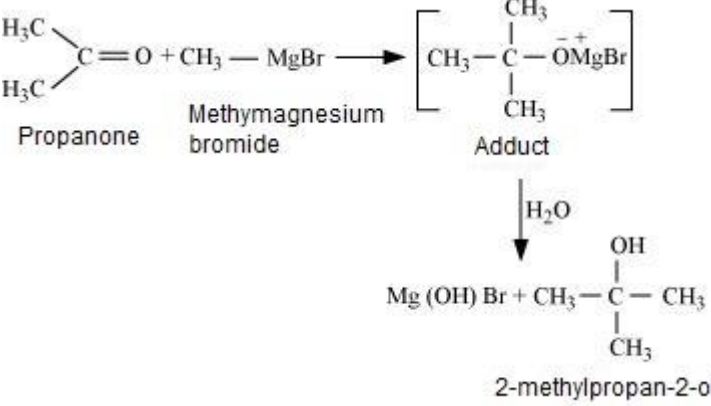
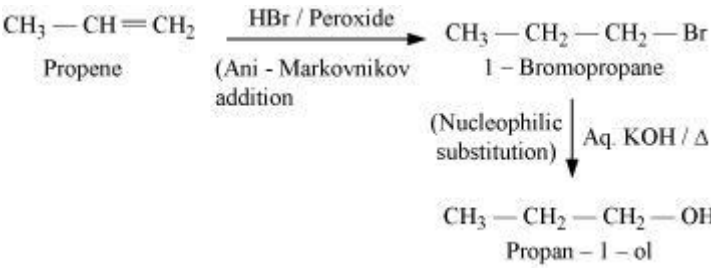
	<p>Divide by 0.8 Po we get $1 + 0.025x = 1.25$ Subtract 1 both side we get $0.025x = 0.25$ Now divide by 0.025 we get $x = 10g$</p> <p>OR $\pi V = CRT$ $4.98 = 36/180 \times R \times 300 = 60 R \dots\dots\dots(i)$ $1.52 = C \times R \times 300 \dots\dots\dots(ii)$</p> <p>Divide (ii) by (i) $C = 0.061M$</p>	<p>$\frac{1}{2}$</p> <p>1 $\frac{1}{2}$ $\frac{1}{2}$</p> <p>$\frac{1}{2}$ $\frac{1}{2}$ for unit</p>
18.	<p>(i) </p> <p style="text-align: center;">Benzoquinone</p> <p>(ii) </p> <p>(iii) </p>	<p>1</p> <p>1</p> <p>1</p>
19.	<p>(i) $R-\overset{\overset{O}{\parallel}}{C}-NH_2 + Br_2 + 4NaOH \longrightarrow RNH_2 + Na_2CO_3 + 2NaBr + 2H_2O$</p>	1

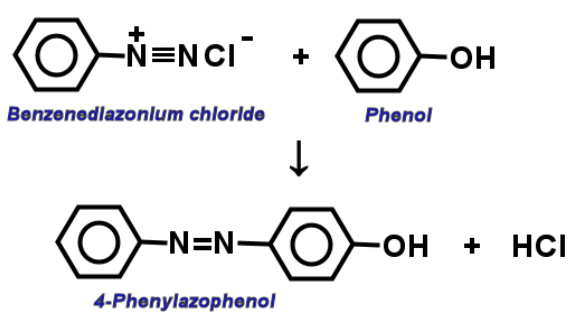
	 <p style="text-align: center;"> <i>Benzenediazonium chloride</i> + <i>Phenol</i> ↓ <i>4-Phenylazophenol</i> + HCl </p>	1
	(ii)	
	(iii) Aniline will give azo dye test whereas methylamine will not	1
20.	(i) α helix-Intramolecular H bonding. β pleated-Intermolecular H bonding. (ii) Amylose is a straight chain polymer of D glucose whereas amylopectin is a branched polymer.	1 1 $\frac{1}{2}$ $\frac{1}{2}$
21.	(i) Slope = $-\frac{k}{2.303}$ $k = -2.303 \times -2.0 \times 10^{-6} \text{ sec}^{-1}$ $= 4.606 \times 10^{-6} \text{ sec}^{-1}$. (ii) $t_{1/2} = \frac{A_0}{2k}$	1 1 1
22.	(i) Addition polymers: Polyvinyl chloride, Polythene. Condensation polymers: Terylene, Bakelite. (ii) Buna- N: 1,3-Butadiene + Acrylonitrile. Buna -S: 1,3-Butadiene + Styrene.	$\frac{1}{2} + \frac{1}{2}$ $\frac{1}{2} + \frac{1}{2}$ $\frac{1}{2} + \frac{1}{2}$
23.	(i) Caring, empathetic, awareness, application of knowledge at right place. (ii) Because of production of histamine. Doctor will prescribe antihistamine. (iii) Medicines can be potent poisons. (iv) An agonist is a chemical that binds to a receptor and activates the receptor to produce a biological response. Antagonist is a drug that blocks a receptor.	$\frac{1}{2} + \frac{1}{2}$ $\frac{1}{2} + \frac{1}{2}$ 1 $\frac{1}{2} + \frac{1}{2}$
24.	(i) $\kappa = \frac{G^*}{R}$ $\Lambda_m = \frac{1000 \kappa}{C}$ $E_{Ni^{2+}/Ni} = -0.25 - \frac{0.0591}{2} \log \frac{1}{0.50}$ $= -0.259V$ $E_{Al^{3+}/Al} = -1.66 - \frac{0.0591}{3} \log \frac{1}{0.001}$ $= -1.719V$ $E_{cell} = 0.259V - (-1.719V) = 1.46V$ OR (i) $E_{H^+/1/2 H_2} = E^0_{H^+/1/2 H_2} - \frac{0.0591}{n} \log \frac{1}{[H^+]}$	1 1 1 1 1 1

26.

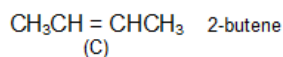

The compound C is obtained by dehydration of B, thus the latter should be

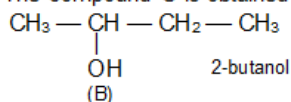

Finally, B is obtained by the reduction of A. Hence, the compound A should be

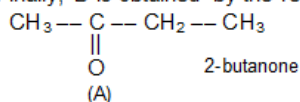

The equations involved are as follows:

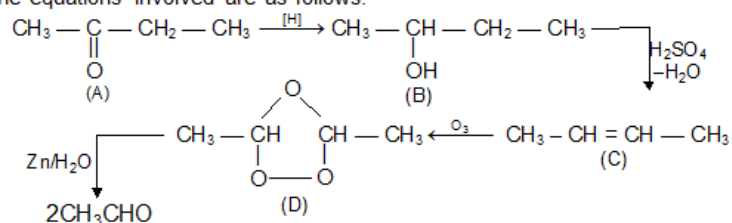

(ii)

(a)

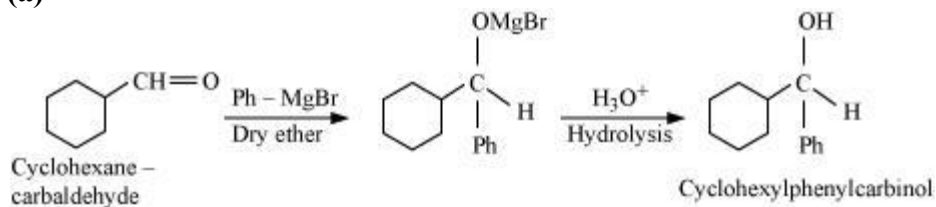

(b)

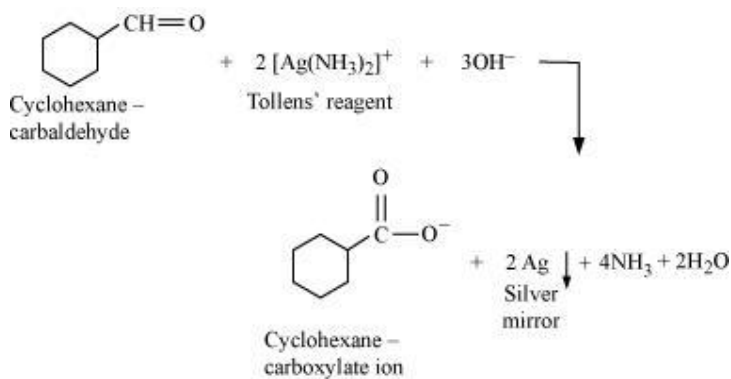

OR

(a)

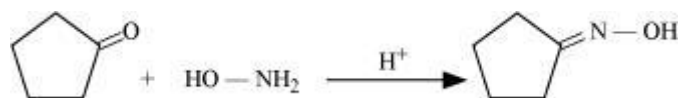

(b)

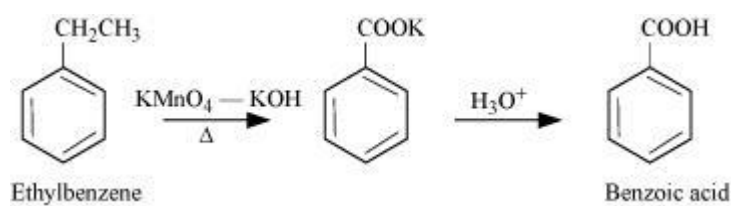

1

(c)

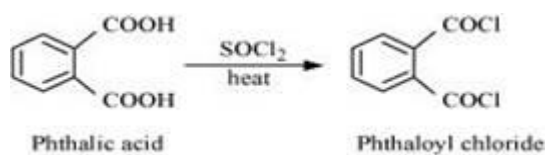

1

(d)

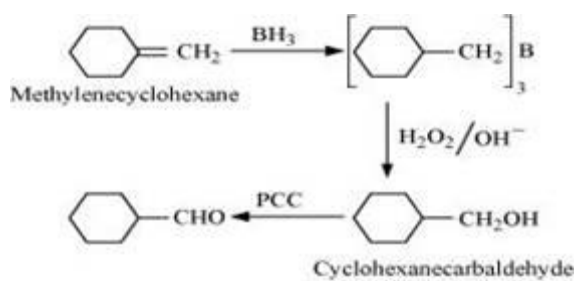

1

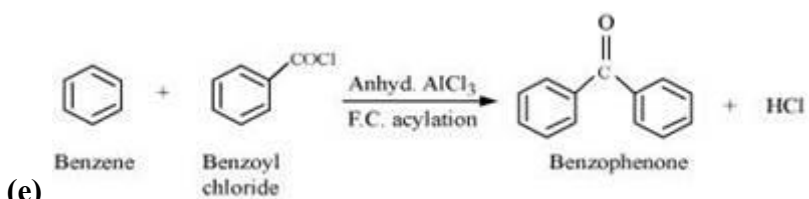

1

(e)