

Blue Print for Unit Test

	AS ₁	AS ₂	AS ₃	AS ₄	AS ₅	AS ₆ &AS ₇	
Essay	(1) ⁴	-	-	(1) ⁴	-	-	
Short	-	(1) ²	(1) ²	-	(1) ²	(1) ²	
Very Short	(3) ¹	-	-	-	-	(1) ¹	
MCQ	(6) ^½	(1) ^½	(1) ^½	-	(1) ^½	(1) ^½	
Total	10	2½	2½	4	2½	3½	= 25M

Academic Standards weightage Table

AS ₁	-	10
AS ₂	-	2.5
AS ₃	-	2.5
AS ₄	-	4
AS ₅	-	2.5
AS ₅ & AS ₆	-	3.5

Type of Question Table

Essay	$2 \times 4 (M)$	=	10 M
Short Answer	$4 \times 2 (M)$	=	8 M
Veru Short	$4 \times 1 (M)$	=	4 M
MCQ	$10 \times \frac{1}{2} (M)$	=	5 M

Syllabus for Unit Exams

Sl. No.	Unit Test	Month	Syllabus for Unit Exams
1.	I	July	1. Heat 2. Chemical reactions and equations 3. Reflection of light by different surface
2.	II	August	1. Acids, Bases and Salts 2. Refraction of light at plane surface
3.	III	November	1. Human Eye and colourful world 2. Structure of Atom 3. Classification of Elements the periodic table
4.	IV	February	1. Electro magnetism 2. Principles of Metallurgy 3. Carbon and its compounds

Unit Test - I
Sub: Physical Sciences
Topic: Heat, Chemical Reactions and Equations

Class: X

Max Marks: 25

Time: 60 min

I Answer all the questions **4 × 2 = 8 marks**

1. $2 \text{Ca}(\text{NO}_3)_2 \rightarrow 2\text{CaO} + 4\text{NO}_2 + \text{O}_2 \uparrow$
From the above equation, how many moles of NO_2 is evolved when two moles of $\text{Ca}(\text{NO}_3)_2$ is decomposed.
2. Explain the concept, why water in a new clay pot are cool?
3. During winter season you wear woolen clothes to keep your body warm. How woolen clothes helps us keep our body warm.
4. Iron oxide reacts with aluminium to form Iron and aluminium trioxide. Write the balanced chemical equation for the above reaction.

II Answer all questions **4 × 1 = 4 marks**

5. Formula of water is H_2O . Why can't we write as HO_2 explain?
6. How can you prevent currosion?
7. Three bodies A, B, C are in thermal equilibrium. Temperature of A is 30°C then what is temperature of C.
8. What is the difference between boiling and evaporation?

III Answer all questions **2 × 4 = 8 marks**

9. Two thermometers are self in two vessels containing same liquid
 - a) Internal energy of which liquid is more ?
 - b) What do you generalise from the above diagrams?
 - c) Find the fault in one of the above diagrams?
10. Calculate the volume, mass and number of molecules of hydrogen liberated when 230g of sodium reacts with excess of water at S.T.P. (atomic mass of Na = 23U, O = 16U and H = 1U).

IV Answer all questions. Pick the correct answer **10 × ½ = 5 marks**

11. Different gases are at same temperature. Which of the following is same for all gases. ()
 - a) mass
 - b) Velocity
 - c) momentum
 - d) Average kinetic energy

12. Convert 173K into °C ()
 a) 446°C b) -100°C c) 0°C D) -446°C
13. Which of the following is not correct. ()
 a) No heat transfer takes place between the bodies of the system if the system is at thermal equilibrium.
 b) The boiling temperature of water increases with the increase in pressure.
 c) the kinetic energy of the molecule is zero when the liquid is at °C
 d) 80000cal of heat is required for 1 kg ice at 0°C to becoming water.
14. A water bottle is filled completely with water, close the lid and keep in deep freeze. What do you conclude with this experiment? ()
 a) When temperature decreases, glass bottle contract and breaks.
 b) When temperature decreases, glass bottle expand and breaks.
 c) When water becomes ice, its volume increases and bottle breaks.
 d) When water becomes ice, its volume decreases and bottle breaks.
15. Wet clothes dry in rooms. Why ? ()
 a) evaporation b) condensation
 c) boiling d) melting
16. In Lays, Kurkure packets chips can be protected for long time. The gas used in these packets is ()
 a) Oxygen b) Nitrogen c) Hydrogen d) Carbon dioxide
17. During rainy season power supply interrupted from the poles. Because ()
 a) Due to the formation of metal oxide layer on the wire
 b) Due to the formation of metal sulphide layer on the wire
 c) Due to the formation of metal carbonate layer on the wire
 d) All the above
18. Which of the following is a balanced chemical equation ()
 a) $2\text{Fe} + 3\text{O}_2 \rightarrow \text{Fe}_2\text{O}_3$
 b) $\text{C}_6\text{H}_{12}\text{O}_6 \rightarrow 4\text{C}_2\text{H}_5\text{OH} + \text{CO}_2$
 c) $\text{C}_3\text{H}_8 + \text{O}_2 \rightarrow 2\text{CO}_2 + 4\text{H}_2\text{O}$
 d) $\text{NH}_4\text{NO}_3 \rightarrow \text{N}_2 + 2\text{H}_2 + \text{O}_2$
19. Brahma Reddy, added potassium Iodide Solution to the Lead nitrate solution prepared by Sudhakar. Then the colour of Lead Iodide solution is ()
 a) Green b) Yellow c) Red d) Brown
20. Reducing agent in $\text{CuO} + \text{H}_2 \xrightarrow{\Delta} \text{Cu} + \text{H}_2\text{O}$ ()
 a) CuO b) H_2 c) Cu d) H_2O

	AS ₁				AS ₂				AS ₃				AS ₄				AS ₅				AS ₆ & AS ₇			
	E	SA	VSA	OB	E	SA	VSA	OB	E	SA	VSA	OB	E	SA	VSA	OB	E	SA	VSA	OB	E	SA	VSA	OB
1. Heat	-	(1) ²	-	(1) ^{1/2}	-	-	-	-	(1) ^{1/2}	(1) ⁴	-	-	-	-	-	-	-	-	-	-	-	-	-	(1) ^{1/2}
2. Chemical Reaction & Equations	-	-	(1) ¹	(1) ^{1/2}	-	-	-	(1) ^{1/2}	-	-	-	-	(1) ⁵	-	-	-	-	-	-	-	-	-	-	-
3. Reflections of light	-	-	-	(1) ^{1/2}	-	(1) ¹	-	-	-	-	(1) ¹	-	-	(1) ^{1/2}	(1) ⁵	-	-	-	-	-	-	-	-	-
4. Acids - Basis	-	-	-	(1) ^{1/2}	-	(1) ¹	(1) ^{1/2}	-	(1) ²	-	-	-	(1) ^{1/2}	-	-	-	-	-	-	-	-	-	-	-
5. Refractions of light	-	(1) ²	-	-	-	-	-	-	-	-	-	-	(1) ^{1/2}	-	-	-	-	-	-	-	-	-	-	-
6. Refraction o flight curved surface	-	-	-	(1) ^{1/2}	-	-	-	-	-	-	-	-	-	-	(1) ^{1/2}	-	-	-	-	-	-	-	-	(1) ^{1/2}
7. Human eye****	-	-	-	-	-	(1) ²	-	-	-	-	(1) ¹	-	(1) ⁴	-	-	-	-	-	-	-	-	-	-	(1) ^{1/2}
8. Atomic *****	(1) ⁴	-	-	(1) ^{1/2}	-	(1) ²	-	-	-	(1) ²	-	-	-	-	-	-	-	-	-	-	-	-	-	-
9. Periodic classification	-	(1) ²	-	(1) ^{1/2}	-	-	-	-	-	-	-	-	-	-	(1) ^{1/2}	-	-	-	-	-	-	-	-	-
10. Chemical Bond	(1) ⁴	-	-	-	-	-	-	-	-	-	-	-	-	-	-	-	-	-	-	-	-	-	-	-
11. Current electricity	(1) ⁴	-	-	(1) ¹	(1) ^{1/2}	-	-	-	-	-	-	(1) ^{1/2}	-	-	(1) ⁴	-	-	-	-	-	(1) ⁴	-	-	-
12. Electromagnetic	-	(1) ²	-	(2) ^{1/2}	-	-	-	-	-	-	-	-	-	-	-	-	-	-	-	-	-	-	-	-
13. Metallurgy	-	-	(1) ²	(1) ^{1/2}	-	-	-	-	-	-	-	-	-	-	-	-	-	-	-	-	(1) ⁴	-	-	-
14. Chemistry Carban	-	-	-	(2) ¹	-	-	-	-	(1) ⁴	-	-	-	-	-	-	-	-	(1) ²	-	-	-	-	-	(1) ²

Blue Print for Unit Test

	AS ₁	AS ₂	AS ₃	AS ₄	AS ₅	AS ₆ & AS ₇	TOTAL
Essay Type	[1(P)] ⁴ [2(C)] ⁴		[1(P)] ⁴ [1(C)] ⁴	[1(P)] ⁴	[1(P)] ⁵ [1(C)] ⁵	[1(P)] ⁴ [1(C)] ⁴	
Short Answer	[2(P)] ² [1(C)] ²	[1(P)] ² [1(C)] ²		[1(C)] ²		[1(C)] ²	
Very Short Answer	[1(P)] ¹ [2(C)] ¹	[1(P)] ¹ [1(C)] ¹	[1(P)] ¹				
MCQ	[6(P)] ^½ [5(C)] ^½	[2(P)] ^½ [2(C)] ^½		[1(P)] ^½ [2(C)] ^½		[2(P)] ^½ [1(C)] ^½	
Fill in the Blanks				[3(P)] ^½		[2(P)] ^½	
Matching	[5(C)] ^½						
Total	31	08	09	09	10	12	79

Academic Standards weightage Table

AS ₁	-	31
AS ₂	-	08
AS ₃	-	09
AS ₄	-	09
AS ₅	-	10
AS ₆ & AS ₇	-	12
Total	-	79

General Science Paper - I
Sub: Physical Sciences
(English Version)

Time: 2½ hours

Max Marks:50

Instructions:

1. Answer the questions under part - A on a separate answer book.
2. Write the answer to the questions under part-B on the question paper itself and attach it to the answer book of part-A

Time: 2 hours

Max Marks:35

Section - I
Part-A

5 × 2 = 10

- Note:**
1. Answer any five questions choosing atleast two from each group.
 2. Each question carries two marks.

Group - A

1. Look at the picture,
 - a) What is the refractive index of the denser medium.
 - b) Find the refractive index of denser medium with respect to rarer medium

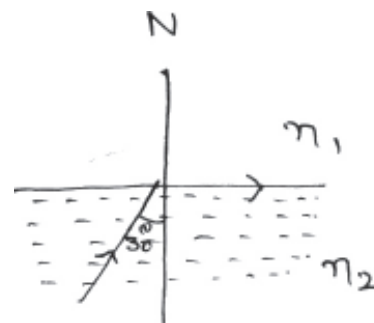

2. Unpolished shoes appears dull, while polished shoes shines brightly guess the reason?
3. When an electron and a neutron are moving through uniform magnetic field with velocity 'v' perpendicular to the direction of magnetic field 'B'
 - a) Which particle deflects? Why?
 - b) What is the path of the deflected particle?
4. Consider a cylinder vessel containing water. A frictionless movable piston is arranged to the cylinder as shown in figure weights are placed on the piston . Heat the system.
 - a) When do you say that boiling process takes place?
 - b) Guess, what happens to boiling point when weights are increased?

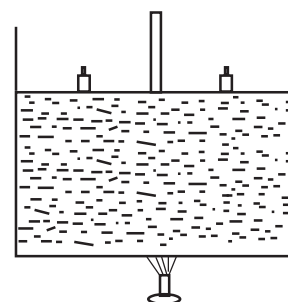

5.

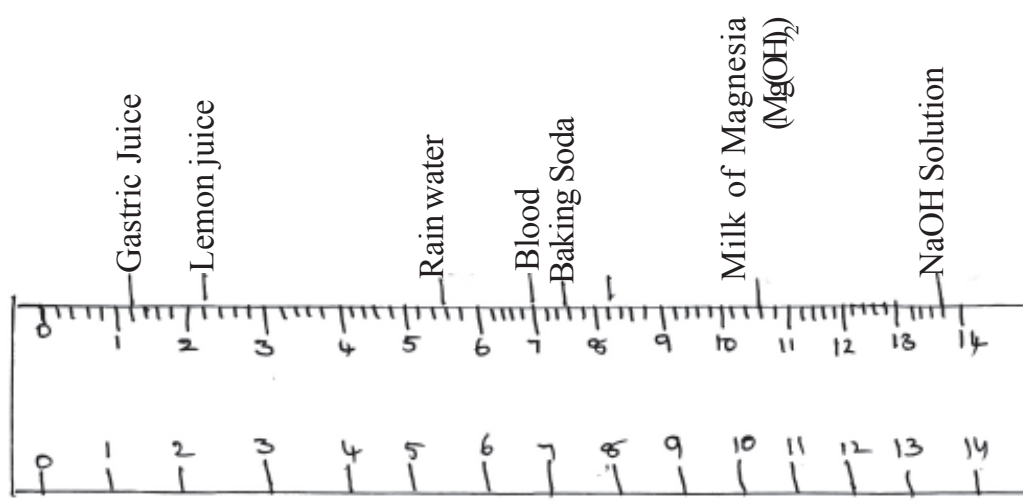

By observing the above pH scale, answer the following

- (i) Which of the body fluid have basic in nature
 - (ii) Is lemon juice a strong acid or weak acid?
 - (iii) Which of the above liquid have strong basic character?
 - (iv) What is the pH of distilled water? (As4)
6. Write the four quantum numbers for the electron that enters last in potassium atom? (AS1)
7. 'X' is an element O belongs to '3rd' period and 13th group then answer the following
- (i) Write the electron configuration of 'X'?
 - (ii) What is the valency of 'X'? (AS2)
8. How do you appreciate the role of Buck minister Pfullerin medicine ? (AS6)

Section - II

4 × 1 = 4

Note: 1. Answer any four questions of the following.

2. Each question carries two marks.

9. Ekambaram is doing an experiment using mirrors to understand the concept of magnification. He identified the situation where the magnification is found to be greater than.
- a) What type of mirror is he used in this experiment?
 - b) What is type position of the object for the above situation?
10. What is the reason for using Tungsten as a filament in electric bulb?
11. When we are inside the water, we use goggle's to see the things clearly? Give reason?

Chemistry

12. What are the compounds formed along with lead oxide when Lead Nitrate is heated? (AS1)
13. How do you appreciate the role of toothpaste in preventing the tooth decay? (AS6)
14. How can you support that Silicon is a metalloid?

Section - III

$4 \times 4 = 16$

- Note:**
1. Answer any four questions choosing atleast two from each group.
 2. Each question carries four marks.

15. Observe the circuit and answer the following questions.

- a) Calculate the current flowing through resistor?
- b) What is the current drawn from the battery?
- c) What is the emf of the battery?

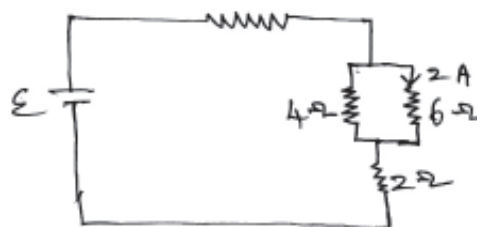

16. Suresh can see the objects clearly which are beyond 3m. So he consulted the doctor and the doctor suggested him some lens.
- a) What type of eye defect he has?
 - b) What kind of lens, doctor suggested him to overcome the eye defect?
 - c) What is the focal length of the lens?

17.

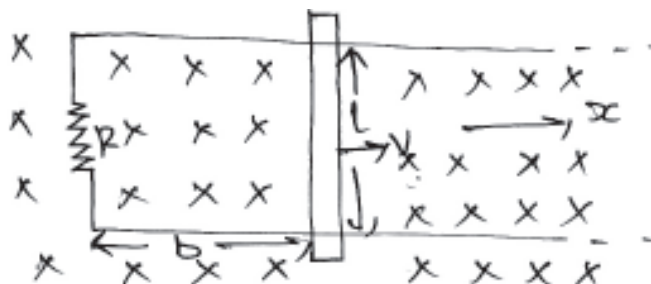

Uniform magnetic field 'B' is acting vertically downwards as shown in figure. A circuit of unthreaded wire with resistance R is kept in the magnetic field. A conductor of length l is placed on the circuit and is moving in x -direction.

- a) If the conductor is moving in positive x -direction with velocity v , what is the change in flux in one second.
- b) What is magnitude and direction of current in the circuit?
- c) What is the power dissipation in the resistor?

18.

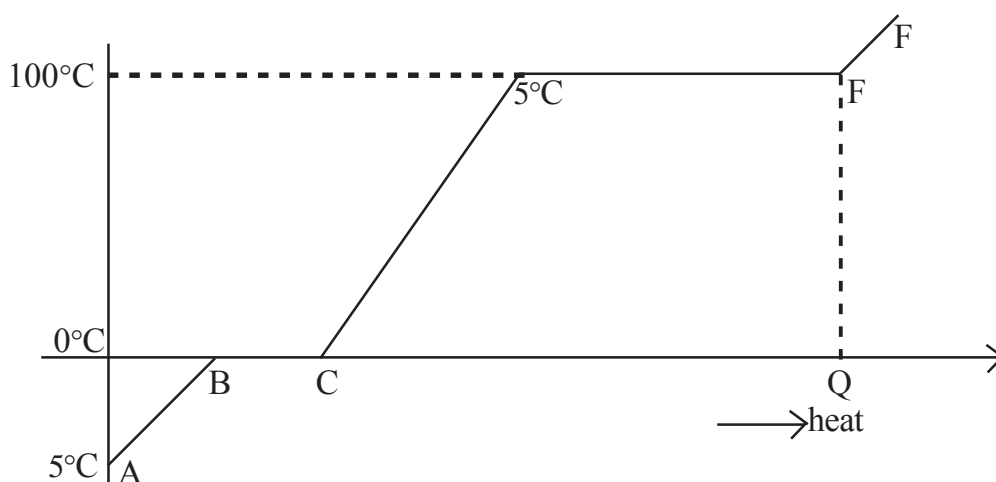

The graph given above shows that an ice of 1kg. at -5°C is heated till it vaporises completely.

- What is the state of ice at C?
- What does the part DE in the graph represent? explain?
- What is the value of Q (heat energy) at E shown in graph?

Group - B

- What are the rules to be followed while filling the electrons in atoms which contains more than one electron? How do you fill the electrons in degenerate orbitals, explain? (AS1)
- Guess the reasons why Ionic compound have more melting and Boiling points when compared to covalent compounds?
- Explain a chemical reaction to show the difference between Ethyl alcohol and Acetic Acid? (AS3)
- Sudheer has observed change of colour in pieces of apple after cutting and also rusting of iron for the iron gate at his home. What could be the reason for all these? Explain the same type of situations in our daily life? (AS6)

Section - IV

$1 \times 5 = 5$

- Note:**
- Answer any one question of the following questions.
 - Each question carries five marks.

- As shown in figure, light ray incident on concave mirror. Using ray rules, construct reflected ray for a given incident ray (Don't use normal). Complete the diagram and explain the steps for getting the reflected ray.

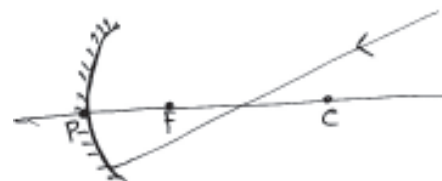

- We know the ratio of Hydrogen and oxygen in water is 2:1, what type experimental arrangement you prefer in order to prove the above fact? Explain with diagram?

General Science Paper - I
Sub: Physical Sciences
(English Version)

Time: 2½ hours

Max Marks:50

Part-B

5 × 2 = 10

Attach Part- B questions paper to the main answer book of part-A

Time: 30 minutes

Marks:15

Instructions:

1. Answer all the questions.
2. Each question carries ½ marks.
3. Answers are to be written in the question paper only.
4. Marks will not be awarded in case of any over writing and rewriting or erased answers.

I Write the capital letter showing the correct answer for the following questions in the brackets provided against them.

1. 10g of ice at 0°C is mixed with 10g of water at 60°C the resultant temperature of the mixture is (consider the heat transfer between these two systems only) ()
A) -20°C B) -10°C C) 0°C D) 20°C
2. An object is kept at the distance of 10 cm from the mirror. If the object is moved 6cm towards the mirror then the difference in the distances of object and image in the two cases is ()
A) 8cm B) 4cm C) 10cm D) 16cm
3. Which of the following is not true for a biconvex lens ()
A) The focal length of biconvex lens is always positive
B) The focal length of biconvex lens depends on material of the lens used and the medium in which it is kept.
C) Biconvex lens can form both virtual and real images for real objects.
D) It is used to correct hypermetropia
4. An real object is kept at 20 cm from the convex lens and its real image is found at 20cm only. What is the focal length of the lens. ()
A) 20cm B) 10cm C) 5cm D) 15cm
5. In an experiment Brahmanandam took 9cm thickness of glass slab, he calculated the vertical slab as 1cm. What is the refractive index of glass slab ()
A) $\frac{9}{8}$ B) $\frac{8}{9}$ C) $\frac{4}{3}$ D) $\frac{9}{7}$

6. A coil is suspended from the ceiling as shown in the figure. A bar magnet is moving towards the coil then which of the following is not correct ()

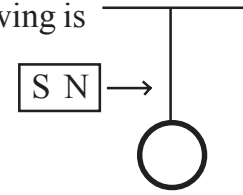

- A) With respect to bar magnet the direction of current in the coil is anti clock wise
 B) The field due to coil is opposite to the field due to bar magnet
 C) The current generated in the coil depends on the velocity of the bar magnet
 D) The emf generated in the coil depends on the resistance of the coil

7. Let the resistance between P and Q is R. Find the equivalent resistance between A and B ()

- A) B) C) D)

8. Which of the following is not true for refraction ()

- A) During refraction frequency of light does not change.
 B) When light ray moves from denser medium to rarer medium the angle of refraction is greater than angle of incidence
 C) During refraction the light always bends at the interface of two medium
 D) A fish in a pond appears closer than its original distance when viewed from top of the pond.

9. An iron box at 60°C contains H_2 gas at 30°C initially which of the following is not true. ()

- A) Heat flows from Iron box to gas
 B) The heat lost by the iron depends on specific heats of iron and H_2 gas and masses of the box and gas.
 C) the system never comes to thermal equilibrium .
 D) At thermal equilibrium the average kinetic energy of iron atom is equal to average kinetic energy of the hydrogen molecule.

10. As shown in the figure an electron is projected perpendicular to the solenoid axis (gaps are available between the turns) The current in the solenoid is anti clock wise assume the magnetic field due to solenoid is uniform. Which of the following diagram is true. ()

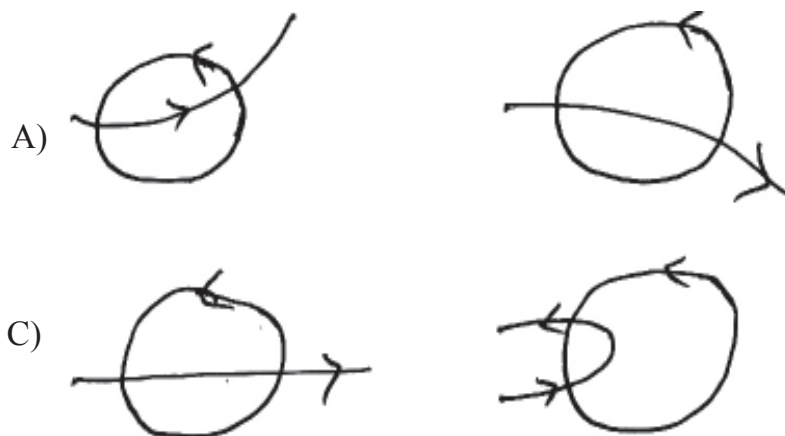

11. $\text{CuSO}_4 + \text{Fe} \rightarrow \text{FeSO}_4 + \text{Cu}$, equation indicates ()
 A) displacement B) decomposition
 C) combination D) Double displacement
12. NaHCO_3 means ()
 A) Baking Soda B) Washing Soda
 C) Di Sodium Hydrogen Carbonate D) All the above
13. Magnetic quantum number values of 3d orbital ()
 A) -1, 0, +1 B) -2, -1, 0, +1, +2 C) 0 D) -3, -2, -1, 0, +1, +2+3
14. Element with atomic number '15' belongs to ____ block in periodic table ()
 A) S-block B) P-block C) d-block D) f-block
15. Nature of substance applied on skin when we stung honey bee ____ ()
 A) Strong acid B) Strong base C) Weak acid D) Weak base
16. Which method is useful to remove impurities from Zinc Blende ____ ()
 A) Hand Picking B) Wsshing C) Froth floatation D) Magnetic Separation
17. Which among the following is an ore of sulphide ____ ()
 A) Carnalite B) Horn Silver C) Cinnabar D) Magnesite
18. During poting process while using green wood the released reducing gases prevent the metal from ____ ()
 A) Reduction B) Oxidation C) neutralisation D) liquation
19. $\begin{array}{c} \text{CH}_2 - \text{CH} - \text{CHO} \\ | \quad | \\ \text{Cl} \quad \text{Cl} \end{array}$, IUPAC Name of the compound is
 A) Cyclo butane B) 2,3 - Di chloro propanal
 C) 3, 2 Di chloro propanal D) 2 Chloro butanadehyde
20. Atomic weight of Beryllium is 9. Then equivalent weights ()
 A) 13.5 B) 9 C) 4.5 D) 2

Fill in the blanks with suitable answers each question carries $\frac{1}{2}$ marks

$10 \times \frac{1}{2} = 5$ marks

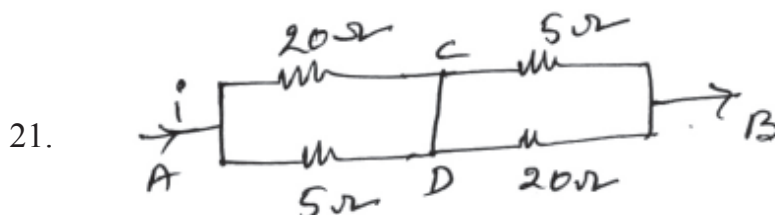

The potential difference between C and D _____

22. The cause of RAINBOW is _____

23.  A biconvex lens of total length f is cut vertically as shown in the figure the focal length of each part in _____

24. A room temperature is 27°C . Its value in kelvin scale is _____

25. Cones is a Eye recognise _____

Section - III

Match the Following

- | | | |
|---|-----|-------------------------------|
| 26. CaOCl_2 | () | a) Hydrated salt |
| 27. $\text{CuSO}_4 \cdot 5\text{H}_2\text{O}$ | () | b) first synthesized compound |
| 28. C_6H_{10} | () | c) Rusting |
| 29. Fe_2O_3 | () | d) Bleaching power |
| 30. NH_2CONH_2 | () | e) Alkyne |
| | | f) Alkene |
| | | g) De hydrated salt. |