

You must have noticed that some things float on water surface and some things sink in it. Did you participate in the activity “floating & sinking” in the lesson on “materials” in class 6? If so, you might have wondered as to why some objects, which you expected to sink, float on water. Did you take one of those objects that floats on water, and tried to see if it floats on kerosene or coconut oil?

### Have a little fun

Take a boiling tube and fill about half of it with water. Add 15 to 20 ml of kerosene to the water. Drop in, one by one, plastic buttons, pins, matchsticks, small pebbles, tiny paper balls, some sand, bits of wax etc. Close the mouth of the boiling tube and shake it well. Wait for some time and observe what happens.



Fig :1

- Did kerosene float above the water or did water float above the kerosene?
- Which objects float in kerosene?
- Which objects sink in kerosene but float on water?
- Which objects sink in water?
- Draw a diagram of the tube, showing the results of your activity.
- Why did different objects behave differently?

We shall try to find answers to these questions in this chapter.

You know that, if a glass marble and a small wooden piece are dropped in water the glass marble sinks in water but a small piece of wood floats on it. Do you know why this happens? We think that a marble sinks in water because it is heavy while the piece of wood floats, because it is light.

Now take a wooden block which is heavier than the marble and put it in water. What happens?

- Why does the wooden block float on water even though it is heavier than a marble?
- What do we mean by ‘heavy’, what do we mean by ‘light’?

To understand the results of the above activity you must understand the meaning of the term heavy. We use this word in our everyday life in two ways. We say “two kilograms of wood is heavier than one kilogram of iron”. At the same time, we also say “iron is heavier than wood”.

Can you explain the difference in meaning of the word ‘heavier’ in both these sentences? In science we try to ensure that each word we use gives the same meaning for everyone. So let’s see in what way these two sentences differ.

The first sentence says that, if we keep two kilograms of wood in one pan of a balance and one kilogram of iron in the other, the beam of balance will tilt towards the pan with wood in it. What is the meaning of the second sentence?

In second sentence when we say iron is heavier than wood, it means if we take a piece of iron and a piece of wood of the same size (that is, they have the same volume) and weigh them, the iron will weigh more than the wood.

In the language of science, it may be stated as “the density of iron is more than that of the wood”. Density is defined as mass per unit volume.

$$\text{Density} = \frac{\text{mass}}{\text{volume}}$$

$$\text{Units for density is } \frac{\text{gm}}{\text{cm}^3} \text{ or } \frac{\text{kg}}{\text{m}^3}$$

We therefore say, the denser object is ‘heavy’ and the less dense object is ‘light’.

## Comparing density – relative density

### Activity-1

Take two test-tubes of the same size and fill one to the brim with water and the other with oil.

- Which will weigh more?
- Which liquid is denser?

Take two equal sized blocks made of wood and rubber.

- Which of these two blocks is heavier?
- Which one is denser?



### Think and discuss

Let us suppose you have two blocks and you do not know what material they are made of. The volume of one block is  $30 \text{ cm}^3$  while the other is  $60 \text{ cm}^3$ . The second block is heavier than the first. Based on this information, can you tell which of the two blocks is denser?

When the volume of two objects is unknown, it is difficult to tell which object is denser solely on the basis of their weights. One way to compare the density of objects is to take equal volumes of the two objects and compare their weights, but this may not be possible for some solids.

For this we can use a simple method of comparing the density of each object with water. In the following activity we shall find out how many times each solid object is dense compared to water. This is known as relative density of that object.

$$\text{Relative density of an object} = \frac{\text{density of the object}}{\text{density of water}}$$

To find the relative density of an object, we must first weigh the object and then weigh an equal volume of water. The two

weights are then compared.

Let us perform an activity to understand how this is done. But first, check your weighing instrument. We shall have to weigh objects several times, so your instrument should function properly.



### Lab Activity 1

**Aim:** Finding the relative density of different objects

**Material required:** overflow vessel, 50ml measuring cylinder, weighing balance and weights or spring balance, rubber erasers, wooden blocks, glass slides, iron nails, plastic cubes, piece of aluminium sheet, glass marbles, stones, cork etc (note: whatever object you take, ensure that its volume is more than 20 cc and it should not be hollow). Record the results of your activity in table 1. (Copy this table in your note book)

Table -1

S.No.	Name of object	Weight of object	Weight of displaced water and cylinder	Weight of water displaced by the object	Relative density of the object
(1)	(2)	(3)	(4)	(5)	(6)

Weigh the 50ml measuring cylinder and note its weight here. Weight = .....

**Procedure:**

Weigh the object, record this in column 3 of the Table 1.

We need to find the weight of water equal to the volume of the object. Pour water in the overflow vessel until it starts dripping from its beak. When water stops dripping from the beak, place the 50ml measuring cylinder under it. Slip the object gently into the overflow vessel as shown in figure 2, ensuring that water does not

splash out. Once the object is in the overflow vessel, water flows out of the beak and collects in the 50 ml. cylinder. Wait till the flow stops. (The object should be fully immersed in water. If the object is not fully immersed, push it in to the water with a pin. see figure 2)

Weigh the cylinder with the water that overflowed and record the weight in column 4.



Fig-2

If we subtract the weight of the measuring cylinder from this weight, we get the weight of water (column 5 of the table 1). This is the weight of water equal to the volume of the object.

Now we can find the relative density of the object (column 6) by taking the weight of the object (column 3) and dividing it by the weight of an equal volume of water (column 5). This tells us how many times denser the object is, compared to water.

**Relative density of an object =**

$$\frac{\text{weight of the object}}{\text{weight of water equal to the volume of the object.}}$$

Find the relative densities of all objects you collected.

Based on the table 1, answer the following questions.

- What is the relative density of wood?
- What is the relative density of glass?
- Which is denser, rubber or plastic?
- Which is denser, wood or cork?
- Classify the above materials as denser than stone and less dense than stone.
- Do objects that have a relative density less than 1 sink in water or float on it?
- Do the objects that sink in water have a relative density less than 1 or more than 1?

What relationship do you find between the relative density of objects and floating-sinking of the objects.

One interesting aspect of relative density is that it has no units. Because

relative density is a ratio of the densities of a material and water. It is a comparison of quantities having the same units, so it has no units.

## Relative density of liquids

We have discussed the relative density of solid objects. We can also find the relative density of liquids. For this, we need to find the weight of a fixed volume of the liquid and the weight of an equal volume of water. The formula for finding the relative density of a liquid is:

**Relative density of a liquid =**

$$\frac{\text{weight of the liquid}}{\text{weight of the same volume of water}}$$

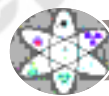

### Lab Activity 2

**Aim:** To find the relative density of milk, groundnut oil and kerosene.

**Material required:** Small bottle of 50 ml. capacity (the bottle should weigh not less than 10gm), weighing balance and weights or spring balance and milk, groundnut oil, kerosene about 50 ml. each in different containers.

**Procedure:** Find the values given below.

Weight of empty bottle = .....

Weight of the bottle with 50ml of water  
= .....

Weight of 50ml of water = .....

Weigh the bottle with milk in it. Record the weight in column 3 of the Table 2.

Repeat this for other liquids and record the weights in column 3. Calculate the weight of each liquid by subtracting the weight of the empty bottle and record it in column 4.

Calculate the relative density of each liquid by comparing the weight of the liquid with the weight of same volume of water and record these values in column 5.

**Table -2**

S. No.	Name of liquid	Weight of the bottle filled with liquid (gm)	Weight of the liquid (gm)	Relative density of the liquid
(1)	(2)	(3)	(4)	(5)
1	Milk			
2	Groundnut oil			
3	Kerosene			

Answer the following questions by comparing Table 1 and Table 2

- Which liquid will float on top if groundnut oil is poured over water?
- If we put a wooden block in kerosene, will it float or sink? Give reasons for your answer.
- A piece of wax floats in water but the same piece sinks in a liquid say liquid 'X'. Will the relative density of liquid 'X' be less than 1 or greater than 1? Why?

Can we use relative density to find out whether water has been added to milk? Let's try and find out.

- If we mix some water in milk, will the relative density of the mixture be less than or more than the relative density of milk? Refer to Table 2 to find the answer.

- If we take two bottles of equal volume and pour pure milk in one and milk mixed with water in the other, which one will be heavier?

We can use a simple instrument to find this out. It is called **lactometer**.

### Activity-2

#### Making of lactometer

Take an empty ball pen refill. It should have a metal point. Take a boiling tube and fill it with water.

Put the refill in with the metallic point inside the water as shown in figure 3 (The refill may not stand vertically in the water as shown in figure, it may slant and cause the top of the refill to touch the wall of the boiling tube. Think what to do to make the refill to stand as shown in figure 3.)

Did the refill sink completely or is some part above the water surface?  
Use a pen to mark the point on the refill to show the part which is above the water surface.

Pour out the water from the boiling tube and fill it with milk. Float the refill in the milk. Did the refill sink up to the same mark as it sank in water? If not, did it sink more or less in milk than in water? Why did this happen?

Put a second mark, on the refill, at the point showing the part which is above the surface of the milk.

Now pour a mixture of milk and water in the boiling tube.

If we put the refill in this mixture, to which point will it sink? Make a guess.

Test if your guess is correct by actually dipping the refill in the milk-water mixture.

Now, are you able to test whether water is added to milk or not by using the above instrument?

We can use a similar instrument, called a hydrometer/densitometer to find out the density of any liquid.

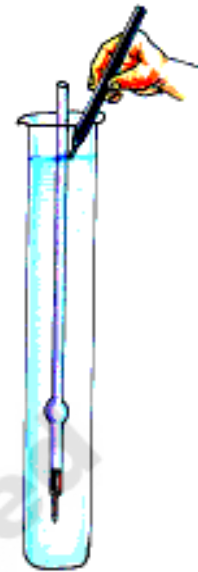

Fig -3: Improved lactometer

### Example 1

What is the effective density of the mixture of water and milk when

- i) they are taken with same masses
- ii) they are taken with same volumes

#### Solution:

Let us say the densities of water and milk are  $\rho_1$  and  $\rho_2$

- i) When they are taken with same mass 'm' and their volumes are  $V_1$  and  $V_2$ , the mass of water  $m = \rho_1 V_1$ ;  $V_1 = \frac{m}{\rho_1}$  and the mass of milk  $m = \rho_2 V_2$ ;  $V_2 = \frac{m}{\rho_2}$

Total mass of water and milk is  $m + m = 2m$

$$\begin{aligned} \text{Total volume of water and milk is } V_1 + V_2 &= \frac{m}{\rho_1} + \frac{m}{\rho_2} \\ &= m \left( \frac{1}{\rho_1} + \frac{1}{\rho_2} \right) \\ &= \frac{m(\rho_1 + \rho_2)}{\rho_1 \rho_2} \end{aligned}$$

The effective density of the mixture ( $\rho_{\text{eff}}$ ) = Total mass / Total volume

$$= \frac{2m}{m(\rho_1 + \rho_2) / \rho_1 \rho_2}$$

$$= \frac{2}{(\rho_1 + \rho_2) / \rho_1 \rho_2}$$

$$= \frac{2 \rho_1 \rho_2}{\rho_1 + \rho_2}$$

ii) when they are taken with same volume 'V' and their masses are m1 and m2

the volume of water  $V = m_1 / \rho_1$

That is  $m_1 = V\rho_1$

and the volume of milk  $V = m_2 / \rho_2$

That is  $m_2 = V\rho_2$

Total mass of water and milk is  $m_1 + m_2 = V\rho_1 + V\rho_2$   
 $= V(\rho_1 + \rho_2)$

Total volume of water and milk is  $V + V = 2V$

The effective density of the mixture ( $\rho_{\text{eff}}$ ) = Total mass / Total volume

$$\rho_{\text{eff}} = \frac{V(\rho_1 + \rho_2)}{2V}$$

$$= \frac{1}{2}(\rho_1 + \rho_2)$$

## When do objects float on water?

### Activity-3

#### Do the objects denser than water float in it ?

Collect small objects as you did for Lab Activity 1. Place them one by one in a glass of water and observe whether they sink or float in water? Record your observations in Table 3.

Take the values of relative densities from table 1.

Table -3

Object	Relative density	Floats / Sinks
Rubber eraser		
Rubber ball		
Plastic cube		
Plastic pen		
Iron nail		
Geometry box		
Glass marble		
Wood		
Stone		

- What do you observe in the above activity?
- Why do some objects float in water though they are denser than water?
- List out the objects that float on water even though they are made up of material which is denser than water.

We know that the substances with a relative density greater than 1 sink in water. But in activity 3, we observed that substances with a relative density greater than 1 sometimes float on water.

So it seems we cannot judge whether a substance will sink or float only on the basis of its relative density. There is definitely some other factor which we need to take into account.

Let's investigate that special property, which a substance that floats has but a substance that sinks doesn't have.

In lab activity 1, we had compared the weight of the substance with the weight of the water displaced by it to find its relative density. In that activity, we immersed the substance fully in water and collected the displaced water.

We shall now do the same activity, but with a slight difference.

The substance will again be put in water. But this time, if it sinks we'll let it sink and if it floats, we'll let it float. We'll then compare the weight of water displaced by it with the weight of the substance.

### Activity-4

#### Is the weight of an object and weight of water displaced by it equal ?

Take a beaker and weigh it. Note down its weight in your note book.

Fill water in an overflow jar. Wait until the water stops dripping from the outlet of the overflow jar. Then take the beaker from the weighing balance and place it below the outlet of the overflow jar. Take a wooden block, moisten it with water and then drop it gently into the overflow jar. Don't forcefully submerge the wooden block in the water. Also, ensure that it does not block the outlet of the overflow jar. Water will flow out of the overflow jar and collect in the beaker kept under the outlet of overflow jar.

Do you think the weight of the water displaced by the wooden block will be less than or equal to or more than the weight of the wooden block? Make a guess. Place the beaker containing the displaced water on one pan of the weighing balance. Take the wooden block, wipe it to clean off water and place it on the other pan along with the weights that equal to the weight of empty beaker as shown in Figure 4.

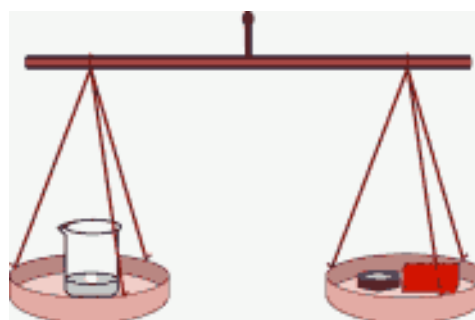

Fig. 4



- Do the two pans balance?
- Is the weight of the water displaced by the wooden block less than, equal to or more than the weight of the wooden block?

Repeat this experiment with several other substances that float or sink. Things

that float could include a plastic bowl, a ball, a steel container, fruits etc.

In each case, check whether the weight of the water displaced is less than, equal to or more than the weight of the substance. Note your observations in the table 4.

**Table -4**

S. No.	Name of the substance	Weight of the substance	Weight of displaced water
1	Plastic bowl		
2	Ball		
3	Steel container		
4	A fruit that floats		
5	A fruit that sinks		
6			
7			
8			

On the basis of the table 4, explain the relationship between the weight of the substances that float and the weight of the water displaced by them.

Can you express this special property of substances that makes the substance to float in the form of a principle?

(The special property of floating substances that you identified in this activity was first discovered by Archimedes. You will know about this further in this chapter.)

Can you think of a way to make iron float on water? Perhaps, the following activity will give you some ideas about how you can make iron float on water.

### Activity-5

#### Making aluminium to float

Take a small sheet of aluminium foil. Fold it four or five times, pressing the foil tight after each fold. You already know the relative density of aluminium from an earlier Lab activity 1. With this given value of the relative density of aluminium, can you guess whether the aluminium foil will float or sink in water?

Drop the folded aluminium foil in the water and test whether your guess is correct or not.

Now unfold the aluminium foil and make it as a small bowl. Place this bowl in the water and see whether it floats or sinks.

- How much water did the bowl of aluminium foil displace?
- Is the water displaced by folded aluminium foil and bowl of aluminium foil the same?

Explain why aluminium bowl floats on the basis of your theory of floating substances.

- Can you now explain why large ships made of iron and steel float on water while a small block of iron sinks in water?
- Why does the metal bowl displace larger amount of water than a metal piece?

To know this you must understand the pressure in fluids.

### Upward force in liquids

When we put an object on the surface of water in a container, the force of gravity, exerted by the Earth, pulls the object downwards i.e. towards the bottom of the container. However, for objects that float on water, there must be an upward force to balance the force of gravity. This upward force must come from water. If the gravitational force on the object is more than the upward force of water, the object will sink in water. Let us do a simple activity to observe this upward force.

#### Activity-6

### Observing the upward force of liquids

Take an empty plastic bottle. Put the cap on it tightly. Place the bottle in a bucket of water. The bottle will float.

Push the bottle into the water by your hand as shown in figure 5.

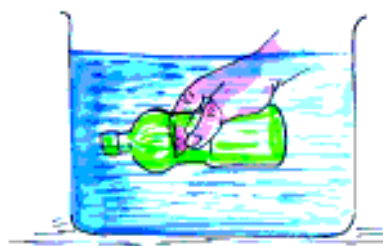

Fig. 5

Do you feel an upward force? Try to push it further down. Do you feel any increase in the upward thrust? In fact, the upward force of water keeps on increasing as you try to push the bottle down. Now, release the bottle and observe how it bounces back to the surface of water! So the upward force of water is a real, observable force. This force acting on unit area of the surface of an object (bottle) is called pressure.

### Pressure of Air

#### Activity -7

### Observing air pressure

Take a glass tumbler. Stick some cotton at the bottom of it. Immerse it inversely in water up to the bottom of the container as shown in figure 6.



Fig. 6

Take out the tumbler from water. Is the cotton attached to its bottom wet? Why?

This is due to the force of air which is applied on water by the air present in the tumbler and stops water from entering the tumbler. This force on unit area of water is pressure of air.

## Atmospheric pressure

All objects on the surface of the earth are subject to constant atmospheric pressure.

Atmospheric pressure = Force of the atmosphere / surface area of the earth

Atmospheric pressure = Weight of the atmosphere / surface area of the earth

Atmospheric pressure = (Mass of the atmosphere)  $\times$  g / (surface area of the earth)

Atmospheric pressure =  $\frac{(\text{average density of the atmosphere}) \times (\text{Volume of the atmosphere}) \times g}{(\text{surface area of the earth})}$

Thus

Atmospheric pressure =  $\frac{\rho \times \text{Surface area of the earth} \times \text{Height of the atmosphere} \times g}{\text{surface area of the earth}}$

Atmospheric pressure =  $\rho \times (\text{Height of the atmosphere}) \times g$

Atmospheric pressure =  $\rho h g$

$P_0 = \rho h g$

## Measuring atmospheric pressure

We cannot experience this atmospheric pressure, but we can recognize and measure it with barometers. The first barometer is invented by 'Torricelli' using mercury. (See figure 7)



**Fig-7: Barometer**

At normal atmospheric pressure the mercury barometer shows mercury column with 76 cm height in the glass tube above the surface of the mercury in the bowl. This is known as 1 atmospheric pressure.

- Why is the height of mercury column nearly 76cm in the tube?

What is the state of the mercury column in the tube? It is at rest, so net force on it is zero. The weight of the column in the tube is equal to the force applied on it by the mercury in the bowl due to atmospheric pressure. These two must be equal in magnitude and opposite in direction.

$$\begin{aligned}
 \text{Weight of the mercury column (W)} &= \text{mass of mercury (m)} \times g \\
 &= (\text{Volume}) (\text{density}) g \\
 &= (\text{cross sectional area of the tube}) (\text{height of the column}) \rho g \\
 &= Ah\rho g
 \end{aligned}$$

Let ' $P_0$ ' be the atmospheric pressure.

Force on the column due to the atmospheric pressure =  $P_0 A$

then,

$$Ah\rho g = P_0 A$$

$$P_0 = \rho gh \text{ (of mercury)}$$

$\rho, g$  are constants. So the height of the mercury column depends on atmospheric pressure. we can calculate the value of atmospheric pressure ' $P_0$ ', by substituting the values of height of the mercury column ' $h$ ', density of the mercury ' $\rho$ ' and acceleration due to gravity ' $g$ '.

Height of the mercury column  $h = 76\text{cm} = 76 \times 10^{-2} \text{ m}$

Density of the mercury  $\rho = 13.6 \text{ gr/cc} = 13.6 \times 10^3 \text{ kg/m}^3$

Acceleration due to gravity  $g = 9.8 \text{ m/s}^2$

$$P_0 = h\rho g$$

$$P_0 = (76 \times 10^{-2} \text{ m}) \times (13.6 \times 10^3 \text{ kg/m}^3) \times (9.8 \text{ m/s}^2)$$

$$P_0 = 1.01 \times 10^5 \text{ kg.m/m}^2.\text{s}^2$$

$1 \text{ kg.m/s}^2 = 1 \text{ Newton}$

hence,  $P_0 = 1.01 \times 10^5 \text{ N/m}^2$

This value is called one atmospheric pressure.

$$1 \text{ Atmosphere} = 1.01 \times 10^5 \text{ N/m}^2$$

( $1 \text{ N/m}^2$  is called Pascal)



### Do you know?

The mass of air that would occupy in a cylindrical tube with cross sectional area of  $1\text{cm}^2$  and that extends  $30\text{km}$  up to the top of atmosphere is about  $1\text{kg}$ . The weight applied on the surface area of  $1\text{cm}^2$  on the earth is nothing but atmospheric pressure.

Atmospheric pressure

$$P_0 = mg/A = 1 \text{ kg} \times 10 \text{ m/s}^2 / 1 \text{ cm}^2 = 10 \text{ N/cm}^2 \text{ or } 10^5 \text{ N/m}^2 \text{ (} 10^5 \text{ Pascal)}$$

This value is nearly equal to  $1\text{atm}$ .



## Think and discuss

- What would happen if Toricelli experiment had been done on moon?
- A stopper is inserted in the small hole of the glass tube of the mercury barometer below the top level of the mercury in it. What happens when you pull out the stopper from the glass tube?
- Why don't we use water instead of mercury in Toricelli experiment? If we are ready to do this experiment, what length of tube is needed?
- Find the weight of the atmosphere around the earth (take the radius of earth is 6400km.)

## Pressure at a depth “h” in a liquid

Let us consider a container which contains a liquid in it of density “ $\rho$ ”.

Consider a cylindrical column of height ‘h’ from the surface of liquid of cross sectional area “A”. See the figure 8.

The volume of the liquid column

$$V = Ah$$

$$\text{Mass} = \text{Volume} \times \text{density}$$

$$m = Ah \rho$$

$$\text{Weight } W = mg = Ah \rho g$$

What is the state of the motion of the liquid column?

You know that from Newton's law, the net force on it is zero, b are the forces acting on that water column?

There are three forces acting, which are,

- Weight (W), vertically down
- Force on top surface due to atmospheric pressure ( $P_0 A$ ), acting vertically down
- Force on the bottom surface of the column due to static pressure of liquid (PA), acting vertically up.

From Newton's law we get

$$PA = P_0 A + W$$

$$PA = P_0 A + h \rho g A$$

Fig. 8

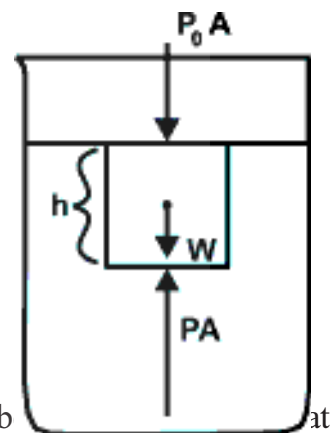

Where  $P$  is the pressure at the depth “ $h$ ” from the surface of the liquid and  $P_o$  is the atmospheric pressure.

$$PA = P_o A + h \rho g A$$

$$P = P_o + h \rho g$$

This means that the pressure inside the liquid at a constant depth is constant.

## Pressure difference at different levels of depth in fluids

Let us consider a cylindrical column of liquid of height ‘ $h$ ’ with cross sectional area ‘ $A$ ’ and let  $\rho$  be the density of the liquid. See the figure 9.

What is the pressure  $P_1$  in the liquid at depth  $h_1$  ?

From equation (1) we get,

$$P_1 = P_o + h_1 \rho g$$

Similarly, pressure  $P_2$  at depth  $h_2$  is given by  $P_2 = P_o + h_2 \rho g$

From (3)-(2) we get

$$P_2 - P_1 = h_2 \rho g - h_1 \rho g$$

$$P_2 - P_1 = \rho g (h_2 - h_1)$$

from the figure  $h = h_1 - h_2$  so

$$\text{we have, } P_2 - P_1 = h \rho g$$

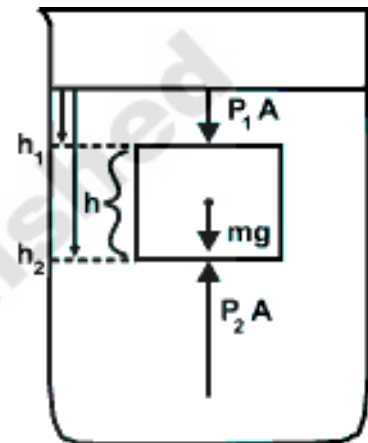

Fig 9

The pressure difference between two levels in that liquid =  $h \rho g$ .

Here density of the liquid ‘ $\rho$ ’ and ‘ $g$ ’ are constants, so the pressure difference increases with a increase in depth.

• **What happens if we replace this cylindrical liquid column with another object which is made up of a material whose density is not equal to the density of liquid?**

The pressure difference in the liquid  $P_2 - P_1 = h \rho g$  (values of the liquid)

$$P_2 - P_1 = h \times m/V \times g$$

$$P_2 - P_1 = h \times m/Ah \times g$$

$$P_2 - P_1 = m/A \times g$$

$$(P_2 - P_1)A = m \times g \text{ (Weight of the displaced liquid)}$$

Since  $F = P \times A$  and  $W = mg$

we get  $F = W$  (values of the displaced liquid)

Here ‘ $F$ ’ is the force applied on the object and ‘ $W$ ’ is the weight of the displaced liquid. So the force applied on the object by the liquid is equal to the weight of the displaced liquid.

The force applied on the object in upward direction is called “**Buoyancy**”. As per the above equation this buoyant force is equal to the weight of the liquid displaced by the object.

## Measuring the force of buoyancy

We have seen that when an object is immersed in water it experiences an upward force, the force of buoyancy. Can we measure this upward force? Let's try.

### Activity-8

#### Let us measure the force of buoyancy

Suspend a stone from a spring balance. Note the reading of the spring balance. The reading gives the weight of the stone. Take a beaker half filled with water. Now immerse the stone in the water. Note the reading of the spring balance. The reading of the spring balance gives the 'weight' of the immersed stone. Do you notice any change in the weight of the stone before and after it gets immersed in water? You may notice that the stone, when immersed, appears to lose some weight.

- Why does the stone lose weight when it is immersed?

The immersed stone appears to lose weight because the force of buoyancy, exerted on the stone by the water, in the upward direction, serves to reduce the force of gravity. Thus the **apparent loss of weight** must be **equal to the force of buoyancy** acting on the immersed stone. We can measure the force of buoyancy exerted by a liquid, by measuring the apparent loss of weight of an object immersed in that liquid. You will notice that in every case an immersed object appears to lose weight.

When the object floats on the surface of water, it appears as if it lost all its weight, that is, the spring balance shows zero reading for floating bodies! For objects that float on a liquid surface, the force of buoyancy balances the force of gravity at the surface of the liquid.

Now let us repeat this activity and measure the weight of the water displaced by the immersed stone.

### Activity-9

#### Measuring the weight of the water displaced by the immersed stone

Suspend a stone from a spring balance. (it is better to take the stone more than 300 gm). Note the reading on the spring balance. The reading gives the weight of the stone. Take an overflow vessel with water and place a graduated beaker below the beak. (Figure 10).

Now immerse the stone in the water. Note the reading on the spring balance and

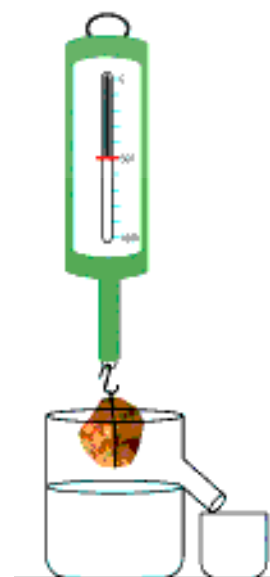

Fig. 10

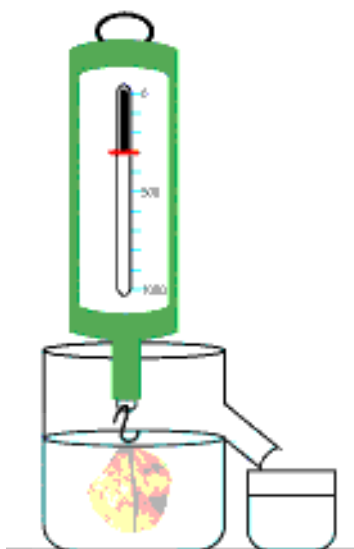

Fig-11

measure the volume of water that overflows into the graduated beaker.

The reading of the spring balance gives the weight of the immersed stone and the beaker reading gives the volume of water displaced by the stone (Figure 11).

- By how much does the weight of the stone appear to be decreased? (Apparent loss of weight of the stone)
- What is the weight of the displaced volume of water?
- Do you observe any connection between the two?

The *apparent loss of weight* of the immersed stone is *equal to the weight of water displaced* by the stone i.e., *equal to the force of buoyancy exerted by the water*.

This wonderful observation was made by Archimedes, an ancient Greek scientist.

### Archimedes' principle

Archimedes' principle states that when a body is immersed in a fluid it experiences an upward force of buoyancy equal to the weight of fluid displaced by the immersed portion of the body.

#### Do you know?



Archimedes (287-212 BC)

Archimedes was a Greek scientist. At that time the King had a crown made of gold. The King however, suspected that the crown made was not of pure gold and asked Archimedes to verify this. Archimedes had to solve the problem without damaging the crown, so he could not melt it down into a regularly shaped body in order to calculate its density. While taking a bath, he noticed that the level of the water in the tub rose as he got in, and realized that this effect could be used to determine the volume of the crown. The submerged crown would displace an amount of water equal to its own volume. By dividing the mass of the crown by the volume of water displaced, the density of the crown could be obtained. This density would be lower than that of gold if cheaper and less dense metals had been added. Archimedes then took to the streets naked, so excited by his discovery that he had forgotten to dress, crying "Eureka!" (meaning "I have found it!").



**THINK!** How did Archimedes solve the King's problem? A simple arrangement could be used to determine whether a golden crown is less dense than gold. The crown and a bar of gold, of the same mass as the crown, are suspended from the two arms of a simple balance as shown in the figure. The balance is lowered into a vessel of water. If the crown (left) is less dense than the gold bar (right), it definitely possesses a larger volume than that of pure gold and will displace more water and thus experience a larger upward buoyant force, causing the balance to tilt towards the gold bar. This would indicate that the crown was not of pure gold!

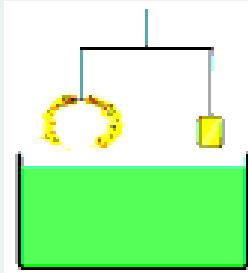

Note: This experiment holds good only when the crown doesn't have any covered hollow portion in it. Think why?

Let's look at the story that is associated with this observation.



### Think and discuss

- Why is it easier for you to float in salt water than in fresh water?
- Why is there no horizontal buoyant force on a submerged body?
- Two solid blocks of identical size are submerged in water. One block is iron and the other is aluminium. Upon which is the buoyant force greater?
- A piece of iron is placed on a block of wood, makes it to float lower in the water. If the iron piece is suspended beneath the wood block, would it float at the same depth? Or lower or higher?

You know that pressure difference at different levels of height inside the liquid causes buoyancy.

- Can we increase the pressure inside the liquid?

It is only possible when the liquid is enclosed. A scientist named Pascal made a principle about what happens when an external pressure is applied to an enclosed liquid. Let us know about it.

### Pascal's principle

Pascal's principle states that external pressure applied to an enclosed body of fluid is transmitted equally in all directions throughout the fluid volume and the walls of the containing vessel.

Look at Figure 12. Here, we have an enclosed volume of fluid in a U-shaped tube. The fluid is enclosed in the tube by

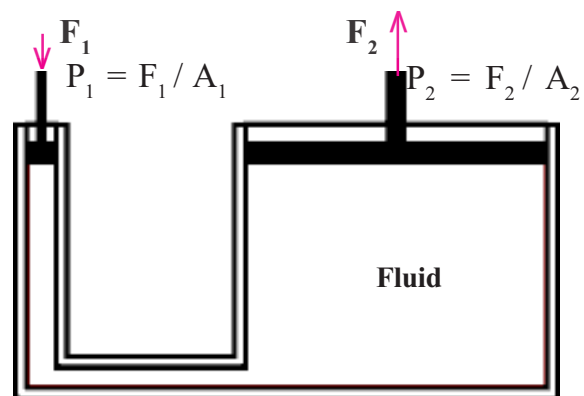

Fig-12: Application of Pascal's principle (bramha press)

two leak-proof pistons in each arm. The ratio of cross-section areas of the right and left tubes is  $A_2 : A_1$  and  $A_2 > A_1$ .

When a force  $F_1$  is applied to the left piston the excess pressure acting on the fluid volume is  $F_1/A_1$ .

According to Pascal's principle, this excess pressure is transmitted equally throughout the fluid volume. That is, every unit area of the fluid 'experiences' this excess pressure of  $F_1/A_1$ .

The excess pressure in the right-side tube (of cross section area  $A_2$ ) is also  $F_1/A_1$  and since its area is  $A_2$ , the upward force acting on the right piston is  $F_2 = A_2 \times F_1/A_1$ ; which is much larger in magnitude than  $F_1$ .

Thus the application of Pascal's principle results in a large upward force (thrust) on the right piston when a small

downward force is applied on the left piston.

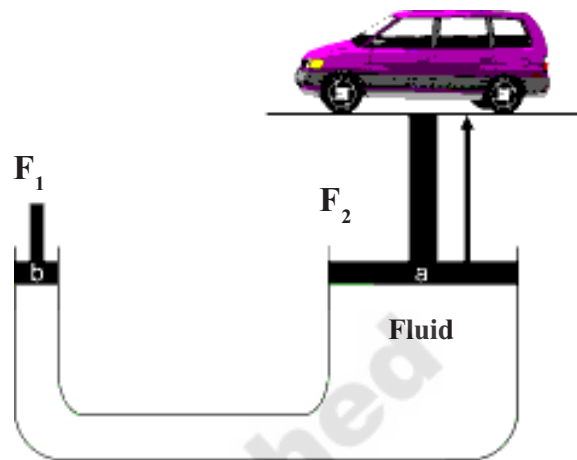

Fig. 13: Hydraulic jack

This principle is used in the design and working of hydraulic jacks/lifts (Fig-13) which you can see in automobile workshops. A small downward force applied by the hand of the operator helps to lift a heavy vehicle with ease!



### Key words

*Density, Relative density, Lactometer, Hydrometer / densitometer, atmospheric pressure, barometer, buoyancy.*



### What we have learnt

- Objects having a density less than the liquid in which they are immersed, float on the surface of the liquid.
- All objects experience a force of buoyancy when immersed in a fluid.
- When an object is immersed in a fluid it appears to lose weight (because of buoyancy).
- The apparent loss of weight of an object, which is immersed in a liquid, is equal to the weight of liquid displaced by the object. (Archimedes' principle)

- When an object floats on the surface of a liquid, it displaces a weight of liquid equal to its own weight.
- The pressure exerted by a liquid increases with depth below the surface of liquid.
- External pressure, applied to an enclosed volume of fluid, is transmitted equally in all directions throughout the fluid volume.(Pascal's principle)



### Improve your learning

1. A solid sphere has a radius of 2 cm and a mass of 0.05 kg. What is the relative density of the sphere? (AS<sub>1</sub>) [Ans: 1.49 ]
2. A small bottle weighs 20 g when empty and 22 g when filled with water. When it is filled with oil it weighs 21.76 g. What is the density of oil ? (AS<sub>1</sub>) [ Ans: 0.88 g/cm<sub>3</sub>]
3. An ice cube floats on the surface of a glass of water (density of ice =0.9 g/cm<sub>3</sub>).When the ice melts will the water level in the glass rise? (AS<sub>1</sub>)
4. The volume of 50g of a substance is 20 cm<sup>3</sup>. If the density of water is 1g/cm<sup>3</sup>,will the substance sink or float when placed on the surface of water ? What will be the mass of water displaced by the substance? (AS<sub>1</sub>) [Ans: 20 g]
5. Find the pressure at a depth of 10m in water if the atmospheric pressure is 100kPa. [1Pa=1N/m<sup>2</sup>] [100kPa = 10<sup>5</sup>Pa = 10<sup>5</sup>N/m<sup>2</sup> = 1 atm.] (AS<sub>1</sub>) [Ans: 198 kPa]
6. Why some objects float on the water? And some sink? (AS<sub>1</sub>)
7. Explain density and relative density and write formulae. (AS<sub>1</sub>)
8. What is the value of density of water? (AS<sub>1</sub>)
9. Find the relative density of wood. Explain the process. (AS<sub>3</sub>)
10. Which is denser, water or milk? (AS<sub>2</sub>)
11. What is buoyancy? (AS<sub>1</sub>)
12. Classify the following things into substances having Relative Density > 1 and Relative Density < 1 Wood, iron, rubber, plastic, glass, stone, cork, air, coal, ice, wax, paper, milk, kerosene, groundnut oil, soap (AS<sub>1</sub>)
13. How can you appreciate the technology of making ships float, using the material which sink in water ? (AS<sub>6</sub>)
14. Can you make iron to float? How? (AS<sub>3</sub>)
15. How can you find the relative density of a liquid? (AS<sub>3</sub>)

16. Find the relative density of different fruits and vegetables and write a list. (AS<sub>3</sub>)
17. Make a lactometer with refill. What you do to make the refill stand vertically straight? (AS<sub>5</sub>)
18. Draw the diagram of mercury barometer. (AS<sub>5</sub>)
19. How do you appreciate Pascal's discovery in helping to make hydraulic jacks. (AS<sub>6</sub>)
20. How do you appreciate Archimedes discovery of force of buoyancy. (AS<sub>6</sub>)
21. You found the relative densities of some solids and some liquids by some activities. List the solids and liquids in increasing order of relative density. (AS<sub>4</sub>)
22. Iron sinks in water, wood floats in water. If we tied an iron piece to the same volume of wood piece, and dropped them in water, will it sink or float? Make a guess and find out whether your guess is correct or wrong with an experiment. Give reasons. (AS<sub>2</sub>, (AS<sub>3</sub>)
23. Liquid brakes in automobiles follow principle of brama press (Pascal's principle). What about air brakes? Collect the information about the working process of air brakes. (AS<sub>4</sub>)
24. Where do you observe Archimedes principle in our daily life? Give two examples. (AS<sub>7</sub>)
25. Where do you observe Pascal's principle in our daily life? Give few examples. (AS<sub>7</sub>)