

**CBSE**  
**Class X Mathematics**  
**Board Paper – 2019**  
**All India Set – 3**

**Time: 3 hours**

**Total Marks: 80**

**General Instructions:**

- (i) **All** questions are compulsory.
- (ii) The question paper consists of **30** questions divided into four sections – A, B, C and D.
- (iii) Section A contains **6** questions of **1** mark each. Section B contains **6** questions of **2** marks each, Section C contains **10** questions of **3** marks each and Section D contains **8** questions of **4** marks each.
- (iv) There is no overall choice. However, an internal choice has been provided in **two** questions of **1** marks each and, **two** questions of **2** marks each, **four** questions of **3** marks each and **three** questions of **4** marks each. You have attempt only **one** of the alternative in all such question.
- (v) Use of calculators is **not** permitted.

**SECTION A**

Question numbers 1 to 6 carry 1 mark each.

1. In Figure 1,  $PS = 3$  cm.  $QS = 4$  cm,  $\angle PRQ = \theta$ ,  $\angle PSQ = 90^\circ$ ,  $PQ \perp RQ$  and  $RQ = 9$  cm. Evaluate  $\tan \theta$ .

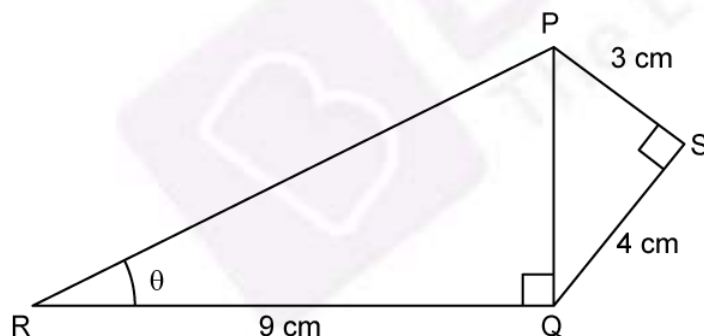

Figure 1

**OR**

If  $\tan \alpha = \frac{5}{12}$ , find the value of  $\sec \alpha$ .

2. Two concentric circles of radii  $a$  and  $b$  ( $a > b$ ) are given. Find the length of the chord of the larger circle which touches the smaller circle.
3. Find the value(s) of  $x$ , if the distance between the points  $A(0,0)$  and  $B(x, -4)$  is 5 units.

4. Find after how many places of decimal the decimal form of the number  $\frac{27}{2^3 \cdot 5^4 \cdot 3^2}$  will terminate.

**OR**

Express 429 as a product of its prime factors.

5. Write the discriminant of the quadratic equation  $(x + 5)^2 = 2(5x - 3)$ .
6. Find the sum of the first 10 multiples of 3.

### SECTION B

Question numbers 7 to 12 carry 2 marks each.

7. If HCF of 65 and 117 is expressible in the form  $65n - 117$ , then find the value of  $n$ .

**OR**

On a morning walk, three persons step out together and their steps measure 30 cm, 36 cm and 40 cm respectively. What is the minimum distance each should walk so that each can cover the same distance in complete steps?

8. A die is thrown once. Find the probability of getting (i) a composite number, (ii) a prime number.
9. Using completing the square method, show that the equation  $x^2 - 8x + 18 = 0$  has no solution.
10. Cards numbered 7 to 40 were put in a box. Poonam selects a card at random. What is the probability that Poonam selects a card which is a multiple of 7?
11. Solve the following pair of linear equations:  
$$3x + 4y = 10$$
$$2x - 2y = 2$$
12. Points A(3, 1), B(5, 1) C(a, b) and D(4, 3) are vertices of a parallelogram ABCD. Find the values of a and b.

**OR**

Point P and Q trisect the line segment joining the point A(-2, 0) and B(0, 8) such that P is near to A. Find the coordinates of points P and Q.

### SECTION C

Question numbers 13 to 22 carry 3 marks each.

13. A class teacher has the following absentee record of 40 students of a class for the whole term. Find the mean number of days a student was absent.

Number of days:	0 - 6	6 - 12	12 - 18	18 - 24	24 - 30	30 - 36	36 - 42
Number of students:	10	11	7	4	4	3	1

- 14.** In Figure 2, PQ is a chord of length 8 cm of a circle of radius 5 cm. The tangents at P and Q intersect at a point T. Find the length TP.

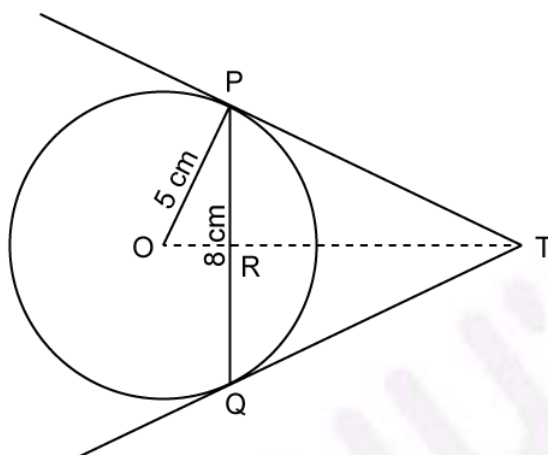

Figure 2

**OR**

Prove that opposite side of a quadrilateral circumscribing a circle subtend supplementary angles at the centre of the circle.

- 15.** A, B and C are interior angles of a triangle ABC. Show that

(i)  $\sin\left(\frac{B+C}{2}\right) = \cos\frac{A}{2}$

(ii) If  $\angle A = 90^\circ$ , then find the value of  $\tan\left(\frac{B+C}{2}\right)$ .

**OR**

If  $\tan(A+B) = 1$  and  $\tan(A-B) = \frac{1}{\sqrt{3}}$ ,  $0^\circ < A+B < 90^\circ$ ,  $A > B$ , then find the values of A and B.

- 16.** Prove that  $\sqrt{3}$  is an irrational number.

**OR**

Find the largest number which on dividing 1251, 9377 and 15628 leaves remainders 1, 2 and 3 respectively.

- 17.** Draw the graph of the equations  $x - y + 1 = 0$  and  $3x + 2y - 12 = 0$ . Using this graph, find the values of x and y which satisfy both the equations.

- 18.** Water in a canal, 6 m wide and 1.5 m deep, is flowing with a speed of 10 km/h. How much area will it irrigate in 30 minutes if 8 cm of standing water is needed?
- 19.** The perpendicular from A on side BC of a  $\Delta ABC$  meets BC at D such that  $DB = 3CD$ . Prove that  $2AB^2 = 2AC^2 + BC^2$ .

**OR**

AD and PM are medians of triangles ABC and PQR respectively where  $\Delta ABC \sim \Delta PQR$ . Prove that  $\frac{AB}{PQ} = \frac{AD}{PM}$ .

- 20.** A chord of a circle of radius 14 cm subtends an angle of  $60^\circ$  at the centre. Find the area of the corresponding minor segment of the circle.  
 (Use  $\pi = \frac{22}{7}$  and  $\sqrt{3} = 1.73$ )
- 21.** Find the value of k so that area of triangle ABC with  $A(k + 1, 1)$ ,  $B(4, -3)$  and  $C(7, -k)$  is 6 square units.
- 22.** If  $\frac{2}{3}$  and  $-3$  are the zeroes of the polynomial  $ax^2 + 7x + b$ , then find the values of a and b.

### SECTION D

Question numbers 23 to 30 carry 4 marks each.

- 23.** Change the following distribution to a 'more than type' distribution. Hence draw the 'more than type' ogive for this distribution.

Class interval:	20 - 30	30 - 40	40 - 50	50 - 60	60 - 70	70 - 80	80 - 90
Frequency:	10	8	12	24	6	25	15

- 24.** The shadow of a tower standing on a level ground is found to be 40 m longer when the Sun's altitude is  $30^\circ$  than when it was  $60^\circ$ . Find the height of the tower. (Given  $\sqrt{3} = 1.732$ )
- 25.** If a line is drawn parallel to one side of a triangle to intersect the other two sides in distinct points, prove that the other two sides are divided in the same ratio.

**OR**

Prove that in a right triangle, the square of the hypotenuse is equal to the sum of the squares of the other two sides.

26. If  $m$  times the  $m^{\text{th}}$  term of an Arithmetic Progression is equal to  $n$  times its  $n^{\text{th}}$  term and  $m \neq n$ , show that the  $(m + n)^{\text{th}}$  term of the A.P. is zero.

**OR**

The sum of the first three numbers in an Arithmetic Progression is 18. If the product of the first and the third term is 5 times the common difference, find the three numbers.

27. In Figure 3, a decorative block is shown which is made of two solids, a cube and a hemisphere. The base of the block is a cube with edge 6 cm and the hemisphere fixed on the top has a diameter of 4.2 cm. Find
- (a) the total surface area of the block.
- (b) the volume of the block formed. (Take  $\pi = \frac{22}{7}$ )

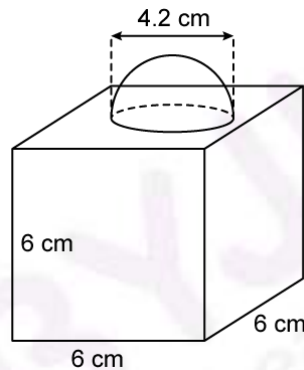

Figure 3

**OR**

A bucket open at the top is in the form of a frustum of a cone with a capacity of  $12308.8 \text{ cm}^3$ . The radii of the top and bottom circular ends are 20 cm and 12 cm respectively. Find the height of the bucket and the area of metal sheet used in making the bucket. (Use  $\pi = 3.14$ )

28. Construct a triangle, the lengths of whose sides are 5 cm, 6 cm and 7 cm. Now construct another triangle whose sides are  $\frac{5}{7}$  times the corresponding sides of the first triangle.

29. Prove that :

$$\frac{\tan^3 \theta}{1 + \tan^2 \theta} + \frac{\cot^3 \theta}{1 + \cot^2 \theta} = \sec \theta \operatorname{cosec} \theta - 2 \sin \theta \cos \theta.$$

30. A motorboat whose speed in still water is 9 km/h, goes 15 km downstream and comes back to the same spot, in a total time of 3 hours 45 minutes. Find the speed of the stream.