

SUBJECT: MATHEMATICS

BLUE PRINT : SA-II CLASS X

Unit/Topic	MCQ (1 mark)	Short answer (2 marks)	Short answer (3 marks)	Long answer (4 marks)	Total
Algebra Quadratic Equations & Arithmetic Progression	1(1)	4(2)	6(2)	12(3)	23(8)
Geometry Circles & Construction	-	6(3)	3(1)	8(2)	17(6)
Trigonometry Heights & Distances	1(1)	-	3(1)	4(1)	08(3)
Probability	1(1)	-	3(1)	4(1)	08(3)
Coordinate Geometry	1(1)	-	6(2)	4(1)	11(4)
Mensuration Areas related to Circles & Surface Areas and Volumes	-	2(1)	9(3)	12(3)	23(7)
Total	4(4)	12(6)	30(10)	44(11)	90(31)

MARKING SCHEME FOR SA – II

SECTION	MARKS	NO. OF QUESTIONS	TOTAL
VSA	1	4	04
SA – I	2	6	12
SA – II	3	10	30
LA	4	11	44
GRAND TOTAL			90

KENDRIYA VIDYALAYA GACHIBOWLI , HYDERABAD - 32
SAMPLE PAPER 04 FOR SA - II (2015-16)

SUBJECT: MATHEMATICS
CLASS : X

MAX. MARKS : 90
DURATION : 3 HRS

General Instructions:

1. All questions are compulsory.
 2. Question paper is divided into four sections: Section A consists 4 questions each carry 1 marks, Sections B consists 6 questions each carry 2 marks, Sections C consists 10 questions each carry 3 marks and Sections D consists 11 questions each carry 4 marks.
 3. There is no overall choice.
 4. Use of Calculator is prohibited.
-

SECTION – A

1. A die is thrown once. Find the probability of getting "at most 2."
2. Find the distance between the point A (7, 3) and the point B on the x -axis whose abscissa is 11.
3. Find sum of 10 terms of following A.P. :

$$\frac{3}{\sqrt{5}}, \sqrt{5}, \frac{7}{\sqrt{5}}, \dots$$

4. In figure $AB=10\sqrt{3}$ cm, $DC=8$ cm and $BD=6$ cm, then find θ .

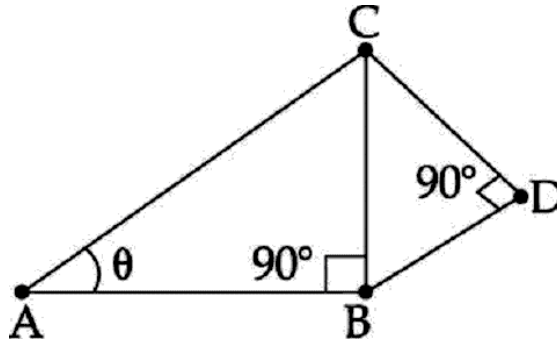

SECTION – B

5. Draw a circle of diameter 7cm. Then, draw two tangents to the circle from a point T at a distance of 7cm from the centre of the circle.
6. In the given figure, in what ratio does P divide line segment AB internally and how many equal parts are marked on ray BY ?

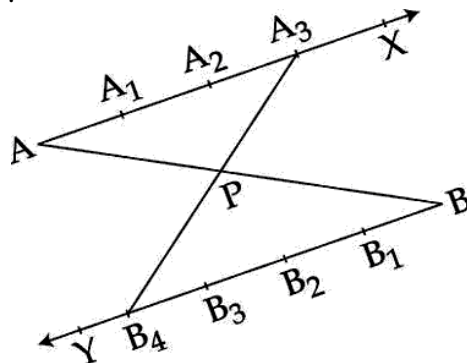

7. Two identical solid cubes of side “a” are joined end to end. Then, find the total surface area of the resulting cuboid.
8. In a certain AP, the 32nd term is twice the 12th term. Prove that 70th term is twice the 31st term.
9. Find the values of p for which the following quadratic equation has two equal roots

$$(p-12)x^2+2(p-12)x+2=0$$
10. Prove that the line segment joining points of contact of two parallel tangents to a circle passes through the centre.

SECTION – C

11. A wall 24 m long. 0.4 m thick and 6 m high is constructed with the bricks each of dimensions 25 cm x 16 cm x 10 cm. If the mortar occupies $\frac{1}{10}$ of the volume of the wall, then find the number of bricks used in constructing the wall.

12. In the given figure, ABCD is a square with side 6 cm. Find the area of the shaded region.

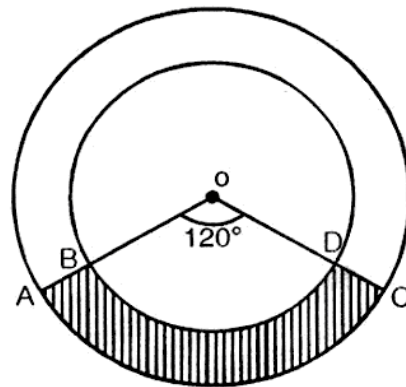
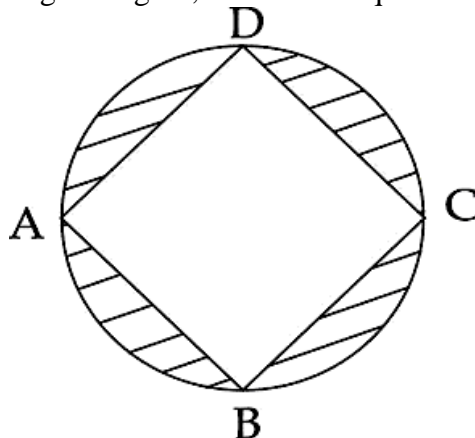

13. In the above right sided figure, two concentric circles with centre O have radii 7 cm and 14 cm. If $\angle AOC=120^\circ$, find the area of shaded region.
 14. The angles of a quadrilateral are in AP, whose common difference is 10° . Find the angles.
 15. A number x is chosen from $-5, -4, -3, -2, -1, 0, 1, 2, 3$. Find the probability that $|x| < 3$.
 16. Show that quadrilateral PQRS formed by vertices P(-2, 5), Q(7, 10), R(12, 11) and S(3, -4) is not a parallelogram.
 17. If the point (x, y) is equidistant from the points (a-b, a+b) and (-a-b, a+b), prove that $x - a = 0$.
 18. Find two consecutive natural numbers whose squares have the sum 145.
 19. A is a point at a distance of 13 cm from the centre O of a circle of radius 5 cm. AP and AQ are tangents to the circle at P and Q. If a tangent BC is drawn at point R lying on the minor arc PQ to intersect AP at B and AQ at C, find the perimeter of ΔABC .
-

20. A man observes the angle of elevation of a bird to be 30° . He then walks 100 m towards the bird which is stationary and finds that the angle of elevation is 60° . Find the height at which the bird is sitting.

SECTION – D

21. Two farmers have circular plots. The plots are watered with the same water source placed in the point common to both the plots as shown in the figure. The sum of their areas is 130 sq.m and the distance between their centres is 14 m. Find the radii of the circles. What value is depicted by the farmers ?

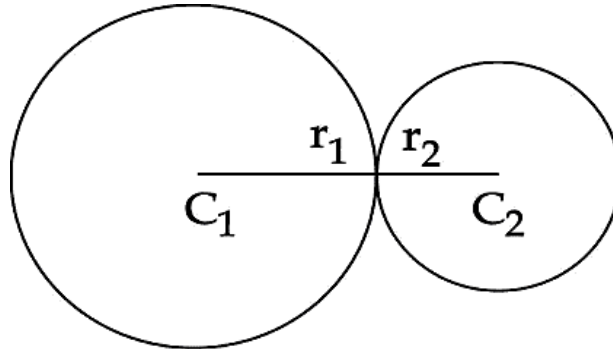

22. The sum of first n terms of an AP is $3n^2 + 4n$. Find its n^{th} term and the AP.
23. In the figure, a tangent PT and a line segment PBA is drawn to a circle with centre O . If $OL \perp AB$, prove that $PA \times PB = PT^2$.

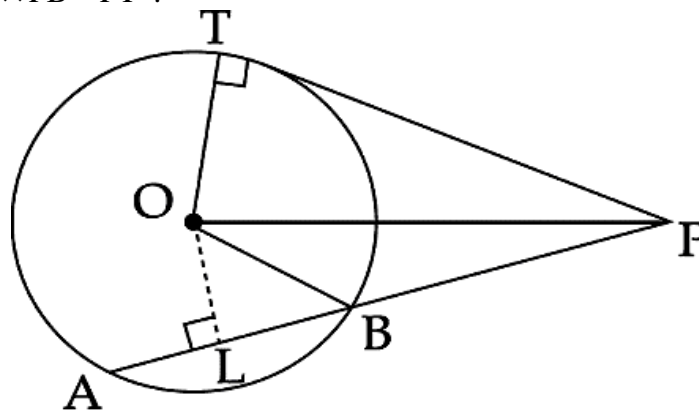

24. Construct a triangle similar to ΔABC whose sides are 2.5 times that of given ΔABC , where ΔABC has sides 3 cm, 5 cm and 6 cm.
25. On a square cardboard sheet of area 784 cm^2 , four congruent circular plates of maximum size are placed such that each circular plate touches the other two plates and each side of the square sheet is tangent to two circular plates. Find the area of the square sheet not covered by the circular plates.
26. The angles of depression of the top and bottom of a 8 m tall building from the top of a multistoried building are 30° and 45° respectively. Find the height of the multistoried building and the distance between the two buildings.
27. Find the ratio in which the line segment joining the points $A(2, -2)$ and $B(3, 7)$ is divided by the line $2x + y - 4 = 0$.
-

28. Ravi plays a game in which he has to draw one ball from a box containing 3 Red, 4 white and 3 green balls. On drawing a white ball Ravi is rewarded with Rs.10. On drawing a red ball Ravi is to pay a penalty of Rs.5 and in other cases there neither any reward nor penalty. Find
- (i) P (Ravi is rewarded Rs.10)
 - (ii) P (Ravi does not lose)
 - (iii) P (Ravi pays a penalty of Rs. 5)
29. A toy is in the form of a right circular cylinder with a right circular cone fixed above it. The diameter and the height of cylindrical part of the toy are 126 cm and 5 cm respectively. The total height of the toy is 21 cm. Find the total surface area of the toy.
30. If the roots of the equation $(a^2 + b^2)x^2 - 2(ac + bd)x + (c^2 + d^2) = 0$ are equal, then prove that $\frac{a}{b} = \frac{c}{d}$.
31. Express $\left(\frac{4x-3}{2x+1}\right) - 10\left(\frac{2x+1}{4x-3}\right) = 3$, $\left(x \neq \frac{-1}{2}, x \neq \frac{3}{4}\right)$ in standard form and then find its roots by factorisation method.
-
-
-