

ICSE Class 10 Maths Previous Year Question Paper 2012

Mathematics (Two and a half hours)

Answers to this Paper must be written on the paper provided separately.

You will not be allowed to write during the first 15 minutes.

This time is to be spent in reading the Question Paper.

The time given at the head of this Paper is the time allowed for writing the answers.

Attempt **all** questions from **Section A** and **any four** questions from **Section B**.

All working, including rough work, must be clearly shown and must be done on the same sheet as the rest of the answer.

Omission of essential working will result in loss of marks.

The intended marks for questions or parts of questions are given in brackets [].

Mathematical tables are provided.

SECTION A (40 Marks)

Attempt **all** questions from this Section.

Question 1

(a) If $A = \begin{bmatrix} 3 & 1 \\ -1 & 2 \end{bmatrix}$ and $I = \begin{bmatrix} 1 & 0 \\ 0 & 1 \end{bmatrix}$, find $A^2 - 5A + 7I$. [3]

(b) The monthly pocket money of Ravi and Sanjeev are in the ratio 5:7. Their expenditures are in the ratio 3:5. If each saves Rs. 80 every month, find their monthly pocket money. [3]

(c) Using the Remainder Theorem factorise completely the following polynomial.
 $3x^3 + 2x^2 - 19x + 6$ [4]

Question 2

(a) On what sum of money will the difference between the compound interest and simple interest for 2 years be equal to Rs. 25 if the rate of interest charged for both is 5% p.a.? [3]

- (b) ABC is an isosceles right angled triangle with $\angle ABC = 90^\circ$. A semi-circle is drawn with AC as the diameter. If $AB = BC = 7$ cm, find the area of the shaded region.
 (Take $\pi = \frac{22}{7}$) [3]

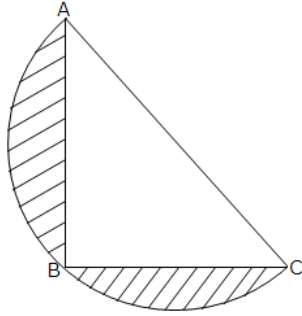

- (c) Given a line segment AB joining the points A(-4, 6) and B(8, -3). Find
 (i) The ratio in which AB is divided by y-axis.
 (ii) Find the coordinates of the point of intersection.
 (iii) The length of AB. [4]

Question 3

- (a) In the given figure O is the centre of the circle and AB is a tangent at B. If $AB = 15$ cm and $AC = 7.5$ cm. Calculate the radius of circle. [3]

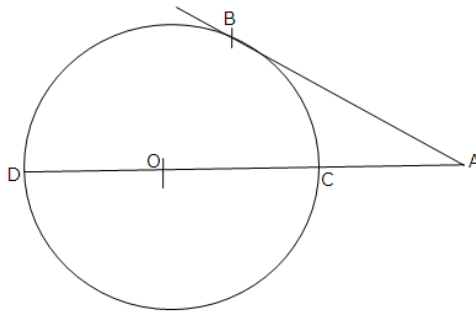

- (b) Evaluate without using trigonometric tables:

$$\cos^2 26^\circ + \cos 64^\circ \sin 26^\circ + \frac{\tan 36^\circ}{\cot 54^\circ} \quad [3]$$

- (c) Marks obtained by 40 students in a short assessment is given below, where a and b are two missing data.

Marks	5	6	7	8	9
Number of Students	6	a	16	13	b

If the mean of the distribution is 7.2, find a and b. [4]

Question 4

- (a) Kiran deposited Rs. 200 per month for 36 months in a bank's recurring deposit account. If the bank pays interest at the rate of 11% per annum, find the amount she gets on maturity. [3]
- (b) Two coins are tossed once. Find the probability of getting
(i) 2 heads (ii) at least 1 tail. [3]
- (c) Using graph paper and taking 1 cm = 1 unit along both x-axis and y-axis.
(i) Plot the points A(-4, 4) and B(2, 2).
(ii) Reflect A and B in the origin to get the images A' and B' respectively.
(iii) Write down the co-ordinates of A' and B'.
(iv) Give the geometrical name for the figure ABA'B'.
(v) Draw and name its lines of symmetry. [4]

SECTION B (40 Marks)

Attempt any **four** questions from this Section

Question 5

- (a) In the given figure, AB is the diameter of a circle with centre O. $\angle BCD = 130^\circ$. Find:
(i) $\angle DAB$
(ii) $\angle DBA$ [3]

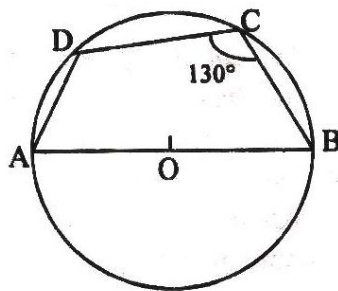

- (b) Given $\begin{bmatrix} 2 & 1 \\ -3 & 4 \end{bmatrix} X = \begin{bmatrix} 7 \\ 6 \end{bmatrix}$. Write:
(i) The order of the matrix X
(ii) The matrix X. [3]

(c) A page from the Savings Bank Account of Mr. Prateek is given below:

Date	Particulars	Withdrawal (In Rs.)	Deposit (In Rs.)	Balances (In Rs.)
January 1 st 2006	B/F	-	-	1270
January 7 th 2006	By Cheque	-	2310	3580
March 9 th 2006	To Self	2000	-	1580
June 26 th 2006	By Cash	-	6200	7780
June 10 th 2006	To Cheque	4500	-	3280
July 15 th 2006	By Clearing	-	2630	5910
October 18 th 2006	To Cheque	530	-	5380
October 27 th 2006	To Self	2690	-	2690
November 3 rd 2006	By Cash	-	1500	4190
December 6 th 2006	To Cheque	950	-	3240
December 23 rd 2006	By Transfer	-	2920	6260

If he receives Rs. 198 as interest on 1st January, 2007, find the rate of interest paid by the bank. [4]

Question 6

- (a) The printed price of an article is Rs. 60,000. The wholesaler allows a discount of 20% to the shopkeeper. The shopkeeper sells the article to the customer at the printed price. Sales tax (under VAT) is charged at the rate of 6% at every stage. Find:
- The cost to the shopkeeper inclusive of tax.
 - VAT paid by the shopkeeper to the Government.
 - The cost to the customer inclusive of tax. [3]

(b) Solve the following inequation and represent the solution set on the number line:

$$4x - 19 < \frac{3x}{5} - 2 \leq \frac{-2}{5} + x, x \in \mathbb{R} \quad [3]$$

(c) Without solving the following quadratic equation, find the value of 'm' for which the given equation has real and equal roots.

$$x^2 + 2(m - 1)x + (m + 5) = 0. \quad [4]$$

Question 7

- (a) A hollow sphere of internal and external radii 6 cm and 8 cm respectively is melted and recast into small cones of base radius 2 cm and height 8 cm. Find the number of cones. [3]
- (b) Solve the following equation and give your answer correct to 3 significant figure:
 $5x^2 - 3x - 4 = 0$ [3]
- (c) As observed from the top of a 80 m tall lighthouse, the angles of depression of two ships on the same side of the light house of horizontal line with its base are 30° and 40° respectively. Find the distance between the two ships. Give your answer correct to the nearest meter. [4]

Question 8

- (a) A man invests Rs. 9600 on Rs. 100 shares at Rs. 80. If the company pays him 18% dividend find:
(i) The number of shares he buys.
(ii) His total dividend.
(iii) His percentage return on the shares. [3]
- (b) In the given figure $\triangle ABC$ and $\triangle AMP$ are right angled at B and M respectively. Given $AC = 10$ cm, $AP = 15$ cm and $PM = 12$ cm.

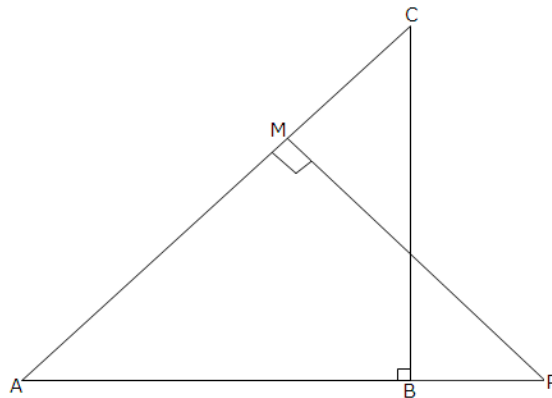

- (i) Prove $\triangle ABC \sim \triangle AMP$
(ii) Find AB and BC. [3]
- (c) If $x = \frac{\sqrt{a+1} + \sqrt{a-1}}{\sqrt{a+1} - \sqrt{a-1}}$, using properties of proportion show that $x^2 - 2ax + 1 = 0$. [4]

Question 9

- (a) The line through A(-2, 3) and B(4, b) is perpendicular to the line $2x - 4y = 5$. Find the value of b. [3]
- (b) Prove that $\frac{\tan^2 \theta}{(\sec \theta - 1)^2} = \frac{1 + \cos \theta}{1 - \cos \theta}$ [3]
- (c) A car covers a distance of 400 km at a certain speed. Had the speed been 12 km/h more, the time taken for the journey would have been 1 hour 40 minutes less. Find the original speed of the car. [4]

Question 10

- (a) Construct a triangle ABC in which base BC = 6 cm, AB = 5.5 cm and $\angle ABC = 120^\circ$.
(i) Construct a circle circumscribing the triangle ABC. [4]
(ii) Draw a cyclic quadrilateral ABCD so that D is equidistant from B and C.
- (b) The following distribution represents the height of 160 students of school.

Height (in cm)	No. of Students
140 - 145	12
145 - 150	20
150 - 155	30
155 - 160	38
160 - 165	24
165 - 170	16
170 - 175	12
175 - 180	8

Draw an ogive for the given distribution taking 2 cm = 5 cm of height on one axis and 2 cm = 20 students on the other axis. Using the graph, determine:

- (i) The median height.
(ii) The interquartile range.
(iii) The number of students whose height is above 172 cm. [6]

- (a) In triangle PQR, $PQ = 24$ cm, $QR = 7$ cm and $\angle PQR = 90^\circ$. Find the radius of the inscribed circle. [3]

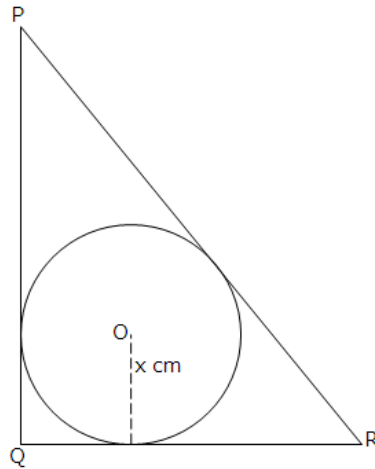

- (b) Find the mode and median of the following frequency distribution: [3]

x	10	11	12	13	14	15
f	1	4	7	5	9	3

- (c) The line through $P(5, 3)$ intersects y-axis at Q. [4]
- Write the slope of the line.
 - Write the equation of the line.
 - Find the co-ordinates of Q.

