

# CBSE Class 12 Physics Sample Paper Solution Set 2

1. Anticlockwise
2. Metal A , because  $v_o' > v_o$
3. The ampere is the value of that steady current which, when maintained in each of the two very long, straight, parallel conductors of negligible cross-section, and placed one metre apart in vacuum, would produce on each of these conductors a force equal to  $2 \times 10^{-7}$  newtons per metre of length.
4. The lens will behave as a diverging lens. The lens is of refractive index lesser than the medium in which it is placed. Hence, its nature does not change.
5. Electric field line is a curve drawn in such a way that the tangent to it at each point is in the direction of the net field at that point. Two fields can never cross each other. If they did ,it means the field at the point of intersection will not have a unique direction, which is meaningless)
6. The frequency belongs to microwave region of the electromagnetic spectrum.
7. Neutrinos interact very weakly with other particles. Since they can penetrate large quantity of matter without interacting they remain undetected throughout the experiments.
8. a.c. voltage is preferred over d.c. because
  - (i) a.c. voltages can be easily stepped up or down with the help of transformers.
  - (ii) Electrical energy can be transmitted efficiently and economically over long distances with higher voltage and lower current.
9. Consider the charging of a capacitor. The electric field between the plates of the capacitor is shown below

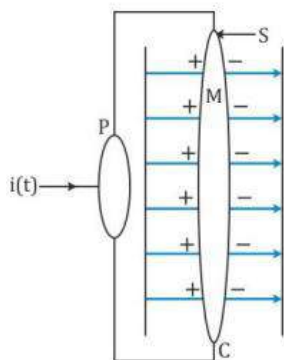

If the plates of the capacitor have an area  $A$  and a total charge  $Q$ , the magnitude of the electric field between the plates is

$$E = \frac{Q}{A\epsilon_0}$$

The field is perpendicular to the surface S as shown in the figure. Thus, using Gauss's law the electric flux through the surface is

$$\phi_E = |E|A = \frac{QA}{A\epsilon_0} = \frac{Q}{\epsilon_0}$$

Now, if the charge Q on the capacitor is changing with time, there is a current  $i = \frac{dQ}{dt}$  associated with it, so we have

$$\frac{d\phi_E}{dt} = \frac{d}{dt} \frac{Q}{\epsilon_0} = \frac{1}{\epsilon_0} \frac{dQ}{dt}$$

$$\therefore \epsilon_0 \left( \frac{d\phi_E}{dt} \right) = i$$

This term is the current due to changing electric field and is called displacement current. Thus, the Ampere's Circuital law is modified to give

$$\oint B \cdot dl = \mu_0 i_c + \mu_0 \epsilon_0 \frac{d\phi}{dt}$$

10. Given:

$$I = 2.7 \text{ A}$$

$$n = 9 \times 10^{28} \text{ m}^{-3}$$

$$e = 1.6 \times 10^{-19} \text{ C}$$

$$A = 2.510^{-7} \text{ m}^2$$

The drift speed is given as

$$v_d = \frac{I}{neA} = \frac{2.7}{(9 \times 10^{28})(1.6 \times 10^{-19})(2.5 \times 10^{-7})} = 7.5 \times 10^{-4} \text{ m/s}$$

11. The terminal voltage across a cell is given as

$V = E - Ir$  Here, E is the e.m.f. of the cell and r is its internal resistance.

The above equation is of the form  $y = mx + c$  where  $y = V$ ,  $m = -r$ ,  $x = I$  and  $c = E$

Hence, the graph of V vs I will be as shown below.

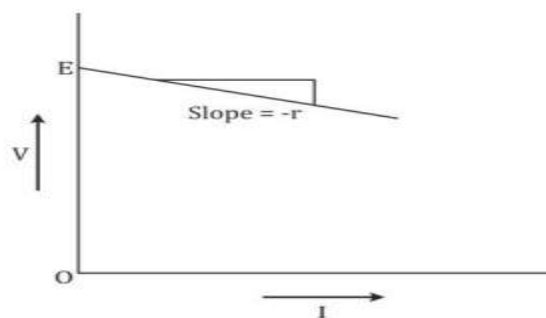

From the graph, it is clear that the y-intercept, that is, the intercept on V-axis gives the value of e.m.f. (E) of the cell. Also, the negative of slope of the graph gives the internal resistance (r) of the cell.

12. The capacitance of two capacitors is same, i.e. C.

The voltage across charged capacitor is  $V_1 = V$  and that across uncharged capacitor is  $V_2 = 0$ .

Thus, the initial energy stored in the capacitor is

$$U_1 = \frac{1}{2} C_1 V_1^2 = \frac{1}{2} C V^2$$

When the charged capacitor is connected across the uncharged capacitor, the two capacitors form a parallel combination.

Thus, the resultant capacitance is  $C' = C + C = 2C$

The initial charge on the capacitor is  $q = CV$

The final potential across the combination will be

$$V' = \frac{q_1 + q_2}{C'} = \frac{q}{2C} = \frac{CV}{2C} = \frac{V}{2}$$

Hence, the final energy in the combination of capacitors is

$$U_2 = \frac{1}{2} C' V'^2 = \frac{1}{2} (2C) \left(\frac{V}{2}\right)^2 = \frac{2CV^2}{8} = \frac{1}{2} \frac{CV^2}{2}$$

Thus, the ratio of energy stored in the combined system to that in the initial single capacitor is given as

$$\frac{U_2}{U_1} = \frac{\frac{1}{2} \frac{CV^2}{2}}{\frac{1}{2} CV^2} = \frac{1}{2}$$

13. The Rutherford model of atom considers the atom as an electrically neutral sphere consisting of a very small, massive and positively charged nucleus at the centre surrounded by the revolving electrons in their respective dynamically stable orbits.

The electrostatic force of attraction  $F_e$  between the revolving electrons and the nucleus provides the centripetal force  $F_c$  to keep them in stable orbits.

$$F_e = F_c$$

$$\frac{mv^2}{r} = \frac{1}{4\pi\epsilon_0} \frac{e^2}{r^2}$$

$$\therefore r = \frac{e^2}{4\pi\epsilon_0 mv^2}$$

The kinetic energy and electrostatic potential energy of the electron in hydrogen atom are

$$K = \frac{1}{2}mv^2 = \frac{e^2}{8\pi\epsilon_0 r}$$

$$U = -\frac{e^2}{4\pi\epsilon_0 r}$$

Thus, the total energy E of the electron in a hydrogen atom is

$$E = K + U = \frac{e^2}{8\pi\epsilon_0 r} - \frac{e^2}{4\pi\epsilon_0 r}$$

$$= -\frac{e^2}{8\pi\epsilon_0 r}$$

The total energy is negative.

The significance of this negative energy is that the electron is bound to the nucleus. If it is positive, then the electron will not follow a closed orbit around the nucleus.

OR

To find the expression of radius, Bohr's second postulate is used. The expression of angular momentum is

$$L = mvr$$

Bohr's second postulate of quantisation says electron revolves only in those orbits for which the angular momentum is integral multiple of  $h/2\pi$ .

$$L = \frac{nh}{2\pi}$$

Thus, for electron in  $n^{\text{th}}$  orbit

$$L = mv_n r_n = \frac{nh}{2\pi} \quad \dots\dots(1)$$

The relation between velocity and radius for electron in  $n^{\text{th}}$  orbit is

$$V_n = \frac{e}{\sqrt{4\pi\epsilon_0 m r_n}} \quad \dots\dots(2)$$

From equations (1) and (2), we get

$$V_n = \frac{e}{\sqrt{4\pi\epsilon_0 m \frac{nh}{2\pi m v_n}}}$$

$$\therefore V_n^2 = \frac{e^2 v_n}{\sqrt{4\pi\epsilon_0 n (h/2\pi)}} \quad \dots(3)$$

$$\therefore V_n = \frac{e^2}{4\pi\epsilon_0 n (h/2\pi)}$$

Substituting (3) in (1), we get

$$r_n = \left(\frac{n^2}{m}\right) \left(\frac{h}{2\pi}\right)^2 \frac{4\pi\epsilon_0}{e^2} \quad \dots(4)$$

This gives the radius of electron in the nth orbit. From equation (4), the radius of innermost orbit  $n = 1$  is found as

$$r_1 = \frac{h^2 \epsilon_0}{\pi m e^2}$$

This is called the Bohr radius and is denoted as  $a_0$ .

14. (i) Field lines around a paramagnetic substance

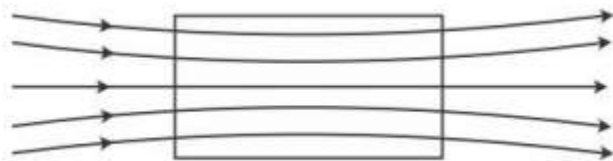

Paramagnetic substances are those which get weakly magnetised when placed in an external magnetic field. They have a tendency to move from a region of weak magnetic field to strong field, that is, they get attracted to a magnet. Hence, when placed in magnetic field, the field lines get concentrated inside the material.

- (ii) Field lines around a diamagnetic substance

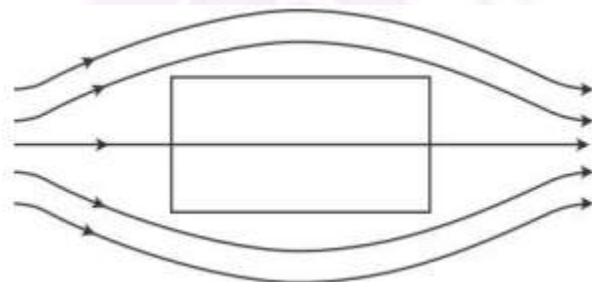

Diamagnetic substances are the ones in which resultant magnetic moment of an atom is zero. When magnetic field is applied, those electrons having orbital magnetic moment in the same direction slow down and those in the opposite direction speed up. This happens due to induced current in accordance with Lenz's law. Thus, the substance develops a net magnetic moment in direction opposite to that of the applied field and hence repulsion is seen.

15. Principle: A junction diode offers a low resistance to current in one direction and a high resistance in the other direction. Thus, the diode acts as a rectifier. Half-wave rectifier: When the diode rectifies only half cycles of the AC wave, it is called half-wave rectifier.

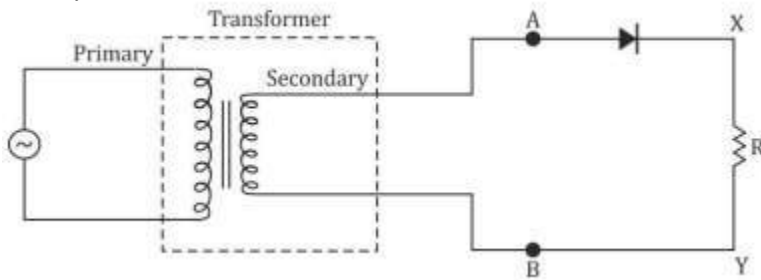

The figure shows the arrangement for using diode as half-wave rectifier. The alternating input signal is fed to the primary of a transformer. The output signal appears across the load resistance  $R_L$ . When the voltage at A is positive, diode is forward biased and it conducts. When voltage at A is negative, diode is reverse biased and it does not conduct. During the positive half of the input signal, the diode is forward biased. The flow of current in the load resistance  $R_L$  is from X to Y. During the negative half of the input signal the diode is reverse biased. The current does not flow through the load resistance.

- 16.

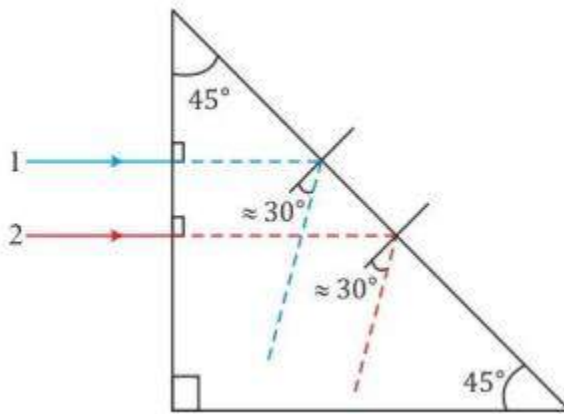

17. The n-p-n transistor as amplifier in CE configuration is shown below

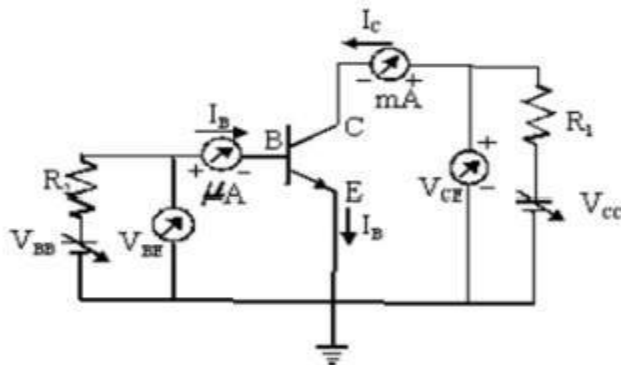

The transistor will work as an amplifier if its operating point is somewhere in the middle of active region.

18. (i) Receiver: A receiver extracts the desired message signals from the received signals at the channel output.

(ii) Demodulator: A demodulator retrieves information from the carrier wave at the receiver.

19. The ray diagram for the image formed by the combination of lens and mirror is shown below.

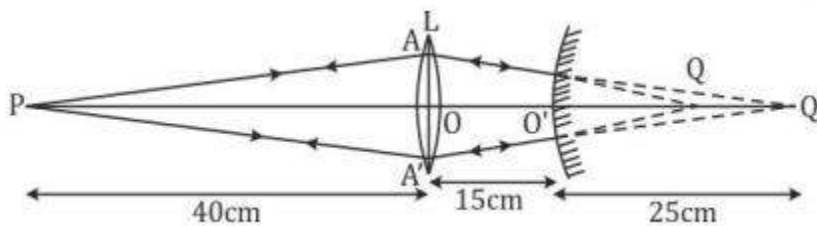

For the convex lens, we have

$u_1 = -40$  cm and  $f = +20$  cm

Hence, using lens formula we get.

$$\frac{1}{v} - \frac{1}{u} = \frac{1}{f}$$

$$\frac{1}{v} = \frac{1}{f} + \frac{1}{u}$$

$$\frac{1}{v} = \frac{1}{20} - \frac{1}{40}$$

$$\frac{1}{v} = \frac{1}{40}$$

$$v = +40 \text{ cm}$$

If only the lens was present, then the image would have formed at  $Q_1$ . But, now this image acts as a virtual object for the convex mirror such that

$$O'Q_1 = \text{distance of virtual object from convex mirror} = OQ_1 - OO' = 40 - 15 = 25 \text{ cm}$$

Hence, for the convex mirror  $u_2 = +25$  cm and  $R = +20$  cm

Using mirror formula, we get

$$\frac{1}{v} - \frac{1}{u} = \frac{2}{R}$$

$$\frac{1}{v} = \frac{2}{R} - \frac{1}{u}$$

$$\frac{1}{v} = \frac{2}{20} - \frac{1}{20}$$

$$\frac{1}{v} = \frac{1}{20}$$

$$v = +20 \text{ cm}$$

Hence, the final image is formed at Q which is 20 cm behind the mirror.

20. The de Broglie wavelength of the electron,

$$\lambda = \frac{h}{\sqrt{2meV}} = \frac{1.227}{\sqrt{V}} \text{ nm}$$

Given:

$$V = 50 \text{ Kv} = 50 \times 10^3 \text{ V}$$

$$\Rightarrow \lambda = \frac{1.227}{\sqrt{50 \times 10^3}} \text{ nm}$$

$$\Rightarrow \lambda = 5.5 \times 10^{-12} \text{ nm}$$

$$\lambda(\text{yellow light}) = 5.9 \times 10^{-7} \text{ m}$$

Resolving Power (RP) is inversely proportional to wavelength. Thus, RP of an electron microscope is about 105 times that of an optical microscope. In practice, differences in other (geometrical) factors can change this comparison somewhat.

21.

Insulator	Conductor	Semiconductor
Energy band gap $E_g$ is very large. ( $E_g > 3 \text{ eV}$ )	In conductors, conduction band and valance band are partially filled or overlap each other.	Energy band gap $E_g$ has finite but small value. ( $E_g < 3 \text{ eV}$ )
Electrical conduction is not possible as there are no electrons in the conduction band.	Conductors have low resistance or high conductivity.	Resistance of semiconductors is not as high as that of the insulators.

22. **Basic modes of communication:**

There are two basic modes of communication: (i) Point – to – point (ii) Broadcast Amplitude modulation: In amplitude modulation, the amplitude of the modulated signal is varied in accordance with the amplitude of the modulating signal so that the frequency of the modulated wave is equal to the frequency of the carrier waves.



Diagram:

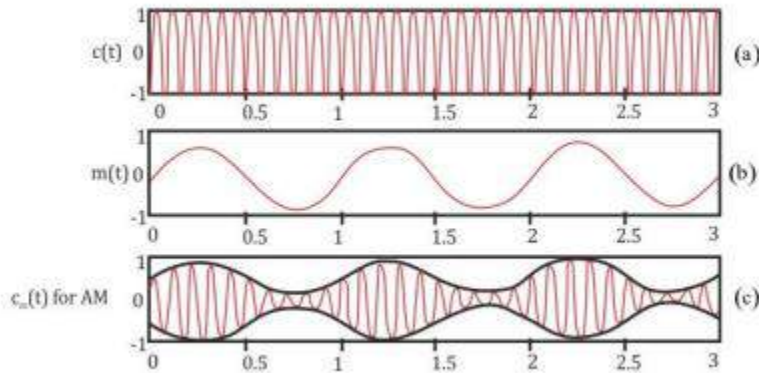

23. (a) Resistance of a wire is inversely proportional to the cross sectional area of the wire. If the copper strips are not thick, then their resistances have to be included in the respective ratio arms. Therefore, copper strips are made thick so that their resistances can be safely ignored.

(b) The percentage error in R is given as,

$$R = S \frac{I_1}{100 - I_1}$$

The percentage error in R can be minimised by adjusting the balance point near the middle of the bridge. i.e., when  $l_1$  is close to 50 cm

(c) Meter bridge wire is made of an alloy such as manganin. It is because; an alloy has high resistivity and a low value of temperature coefficient of resistance.

**OR**

The sliding contact is in the middle of the potentiometer. So, only half of its resistance  $R_0/2$  will be between the points A and B. Hence, the total resistance between A and B say  $R_1$  will be given as

$$\frac{1}{R_1} = \frac{1}{R} + \frac{1}{R_0/2} = \frac{R_0 + 2R}{R_0 R} \quad \dots\dots(1)$$

$$\therefore R_1 = \frac{R_0 R}{R_0 + 2R}$$

The total resistance between A and C will be the sum of resistance between A and B and B and C, i.e.,  $R_1 + R_0/2$ . Therefore, the current flowing through the potentiometer will be

$$I = \frac{V}{R_1 + R_0/2} = \frac{2V}{2R_1 + R_0}$$

The voltage  $V_1$  taken from the potentiometer will thus be given as

$$V_1 = IR_1 = \frac{2V}{2R_1 + R_0} R_1 \quad \dots\dots(2)$$

Substituting (1) in (2), we get

$$\begin{aligned}
 V_1 &= \frac{2V}{2\left(\frac{R_0 R}{R_0 + 2R}\right) + R_0} \times \frac{R_0 R}{R_0 + 2R} \\
 &= \frac{2VR}{2R + R_0 + 2R} \\
 &= \frac{2VR}{R_0 + 4R}
 \end{aligned}$$

24. (a) Aarti showed presence of mind, awareness, critical thinking, decision making, persuasive power and caring nature towards her sister.

(b) Doctors diagnose brain tumour by MRI or CT scans. These techniques involve taking pictures of the brain. Sometimes a special dye made of a radioisotope is injected into the vein of the brain. This dye highlights the various tissues of the brain enabling the doctors to visualise the scan in a better way and helps them in the detection of brain tumour.

25. (a) Consider the rod moving in the presence of magnetic field as shown below.

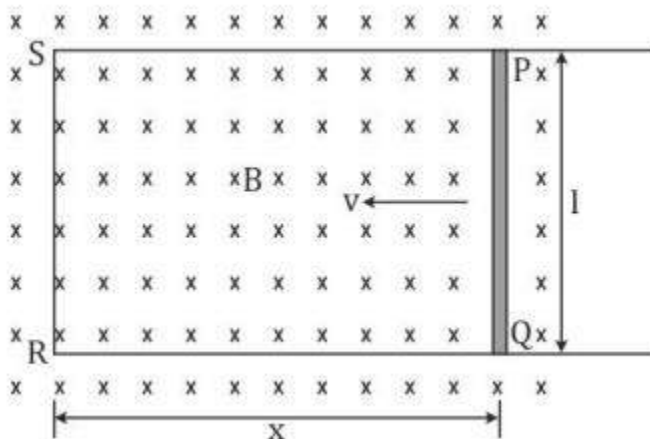

The rod PQ is moved towards left with constant velocity  $v$ . We assume that there is no loss of energy due to friction. PQRS forms a closed circuit enclosing an area that changes as PQ moves. It is placed in a uniform magnetic field  $B$  which is acting downwards and perpendicular to the plane of the system. If the length  $PQ = l$  and  $RS = x$ , the magnetic flux enclosed by the loop PQRS will be  $\Phi_B = Blx$

Since,  $x$  is changing with time the rate of change of flux will induce an e.m.f. as given by

$$\varepsilon = -\frac{d\phi_B}{dt} = -\frac{d}{dt} Blx = -Bl \frac{dx}{dt} = Blv$$

Here,  $\frac{dx}{dt} = -v$ . The negative sign indicates that  $x$  is decreasing with time.

This is the expression of the induced e.m.f. which is also called the motional e.m.f.

(b) This motional e.m.f. can be explained by invoking Lorentz force acting on the free charge carriers of conductor. Consider any arbitrary charge  $q$  in the conductor PQ. When the rod moves with speed  $v$ , the charge also moves with speed  $v$  in the magnetic field  $B$ . The Lorentz force on this charge is  $qvB$  in magnitude, and its direction is towards Q.

The work done in moving the charge from P to Q will be

$$W = qvBl$$

Now, e.m.f. is the work done per unit charge. Hence, we have

$$\varepsilon = \frac{W}{q} = Blv$$

This is the equation of motional e.m.f.

26. (a)

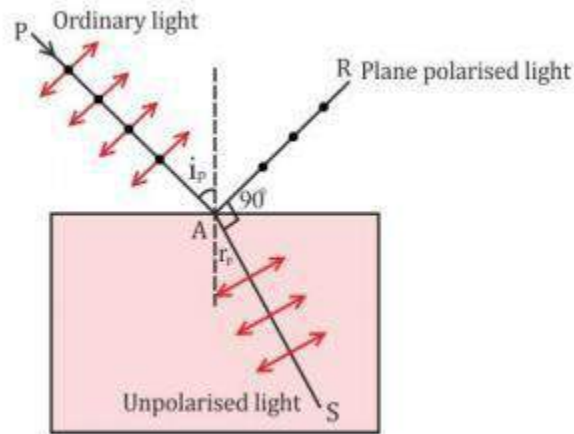

(b) The incident light is unpolarised. The intensity of light, on being transmitted through the first polaroid is;

$$I_1 = I_0 \overline{\cos^2 \theta}$$

$$I_1 = \frac{I_0}{2} \left( \because \overline{\cos^2 \theta} = \frac{1}{2} \right)$$

If  $\theta$  is the angle between the transmission planes of the two polaroids, then the intensity  $I'$  of light on passing through the second polaroid is given by

$$I = I_1 \cos^2 \theta$$

The polaroid P is kept in between  $P_1$  and  $P_2$ .

Hence, the intensity of light transmitted through  $P_3$  is;

$$I_3 = I_1 \cos^2 \theta$$

$$I_1 = \frac{I_0}{2} \text{ and } \theta = 60^\circ$$

$$\Rightarrow I_3 = \frac{I_0}{2} \cos^2 60^\circ = \frac{I_0}{2} \times \left( \frac{1}{2} \right)^2 = \frac{I_0}{8}$$

The angle between the transmission planes  $P_3$  and  $P_2$  is  $30^\circ$ .

$$\Rightarrow I_2 = I_3 \cos^2 \theta$$

$$I_3 = \frac{I_0}{8} \text{ and } \theta = 30^\circ$$

$$\Rightarrow I_2 = \frac{I_0}{8} \cos^2 30^\circ = \frac{I_0}{8} \times \left(\frac{\sqrt{3}}{2}\right)^2 = \frac{3}{32} I_0$$

Hence,

$$I_1 = \frac{I_0}{2} = 0.5 I_0$$

$$I_3 = \frac{I_0}{8} = 0.125 I_0$$

$$I_2 = \frac{3}{32} I_0 = 0.091 I_0$$

27. For an AC circuit, average power is calculated by defining the instantaneous power of the circuit. The instantaneous power of an AC circuit is defined as the product of the instantaneous e.m.f and instantaneous current in it.

A Voltage  $V = V_0 \sin \omega t$  applied to a series LCR circuit drives a current in the circuit given by )

$$i = i_0 \sin (\omega t + \phi).$$

$$i_0 = \frac{V_0}{Z} \text{ and } \phi = \tan^{-1} \left( \frac{X_C - X_L}{R} \right)$$

Where,  $\Phi$  is the phase angle by which current leads the e.m.f. in an AC circuit.  $V_0$  and  $i_0$  are, the peak values of e.m.f. and current respectively.  $X_L$  is the inductive reactance,  $X_C$  is the capacitive reactance and  $Z$  is the total resistance of the circuit.

The instantaneous power  $p$  supplied by source is

$$p = V i$$

$$p = (V \sin \omega t) \times [i_0 \sin (\omega t + \Phi)]$$

$$p = \frac{V_0 i_0}{2} [\cos \phi - \cos(2\omega t + \phi)] \quad \dots\dots(1)$$

The average power over a cycle is given by the average of the two terms in equation (1).

The second term  $\cos(2\omega t + \phi)$  is time-independent. Its average is zero as the positive half of the cosine cancels the negative half.

$$\Rightarrow p = \frac{V_0 i_0}{2} \cos \phi = \frac{V_0}{\sqrt{2}} \frac{i_0}{\sqrt{2}} \cos \phi$$

$$\Rightarrow p = VI \cos \phi \quad \dots\dots(2)$$

$$\Rightarrow p = I^2 Z \cos \phi \quad \dots\dots(3)$$

Equation (3) is the required expression for average power dissipated over a cycle. Average power dissipated depends on voltage, current and the cosine of the phase angle  $\phi$

- (i) When  $\cos \Phi = 0$ , no power is dissipated even though a current is flowing in the circuit.

For purely inductive and capacitive circuit, the phase difference between current and voltage is  $\pi/2$ . Therefore,  $\cos \Phi = 0$

This current is called as wattles current.

- (ii) If the circuit contains only pure R, it is called purely resistive circuit. In that case  $\Phi = 0$ ,  $\cos \Phi = 1$

$$\Rightarrow p = I^2 Z = \text{Maximum dissipated power}$$

28. (a) Consider two coherent sources of light  $S_1$  and  $S_2$  are placed at a distance  $d$  apart. Distance between screen and the plane of the two sources is  $D$ . The spherical waves coming from  $S_1$  and  $S_2$  produces interference fringes on the screen  $GG'$  as shown in the figure below.

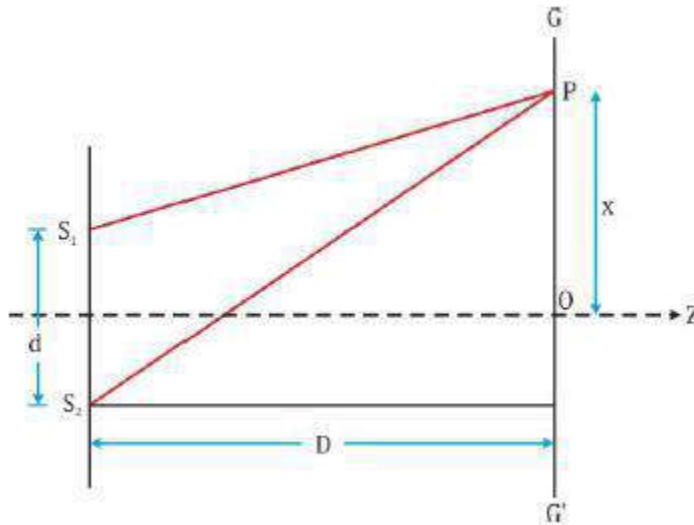

Let  $P$  be an arbitrary point on the line  $GG'$ . The path difference between the light waves reaching at point  $P$  from the sources  $S_1$  and  $S_2$  is;

$$S_2P - S_1P = n\lambda; n = 0, 1, 2, 3, \dots \dots \dots (1)$$

$$(S_2P)^2 - (S_1P)^2 = \left[ D^2 + \left( X + \frac{d}{2} \right)^2 \right] - \left[ D^2 + \left( X - \frac{d}{2} \right)^2 \right]$$

$$= 2xd$$

Where  $S_1S_2 = d$  and  $OP = x$

$$S_2P - S_1P = \frac{2xd}{S_2P + S_1P} \dots \dots (2)$$

In practice, the point  $P$  lies very close to the centre of screen  $O$ .

Therefore,  $S_2P \approx S_1P \approx D$  (If  $x, d \ll D$ )

Hence, negligible error will be introduced if  $2 \frac{1}{S_2P + S_1P}$  is replaced by  $\frac{1}{D}$ .

From (2),

$$S_2P - S_1P \approx \frac{xd}{D} \dots \dots \dots (3)$$

Hence, Condition for constructive interference resulting in a bright region is;

$$x = x_n = \frac{n\lambda D}{d}; n = 0, \pm 1, \pm 2, \dots \dots \dots$$

Condition for destructive interference resulting in a dark region is;

$$x = x_n = \left( n + \frac{1}{2} \right) \frac{\lambda D}{d} \quad ; n = 0, \pm 1, \pm 2, \dots$$

The dark and bright bands appearing on the screen are called fringes. Dark and bright fringes are equally spaced and the distance between two consecutive bright and dark fringes is given by,

$$\beta = x_{n+1} - x_n$$

$$\text{Or } \beta = \frac{\lambda D}{d} \quad \dots(4)$$

Equation (4) is the required expression for the fringe width.

(b) When two light waves of amplitudes  $a$  and  $a$  differing in phase by  $\phi$  interfere, the intensity of the resultant light is given by,

$$I = a_1^2 + a_2^2 + 2a_1 a_2 \cos \phi$$

The intensity of light will be maximum, when  $\phi = 0$

$$I_{\max} = a_1^2 + a_2^2 + 2a_1 a_2 \cos 0$$

$$= a_1^2 + a_2^2 + 2a_1 a_2 \times 1$$

$$I_{\max} = (a_1 + a_2)^2$$

The intensity of light will be minimum, when  $\phi = \pi$

$$I_{\min} = a_1^2 + a_2^2 + 2a_1 a_2 \cos \pi$$

$$= a_1^2 + a_2^2 + 2a_1 a_2 \times (-1)$$

$$I_{\min} = (a_1 - a_2)^2$$

Hence,

$$\frac{I_{\max}}{I_{\min}} = \frac{(a_1 + a_2)^2}{(a_1 - a_2)^2}$$

Given :

$$I_{\min} : I_{\max} = 9 : 25$$

$$\Rightarrow \frac{I_{\max}}{I_{\min}} = \frac{(a_1 + a_2)^2}{(a_1 - a_2)^2} = \frac{25}{9}$$

$$\Rightarrow \frac{(a_1 + a_2)}{(a_1 - a_2)} = \frac{5}{3}$$

$$\Rightarrow \frac{(a_1 + a_2) + (a_1 - a_2)}{(a_1 + a_2) - (a_1 - a_2)} = \frac{5 + 3}{5 - 3}$$

$$\Rightarrow \frac{a_1}{a_2} = \frac{4}{1}$$

Slit width  $w \propto a^2$

$$\frac{w_1}{w_2} = \frac{a_1^2}{a_2^2} = \frac{16}{1}$$

$$w_1 : w_2 = 16 : 1$$

OR

(a)

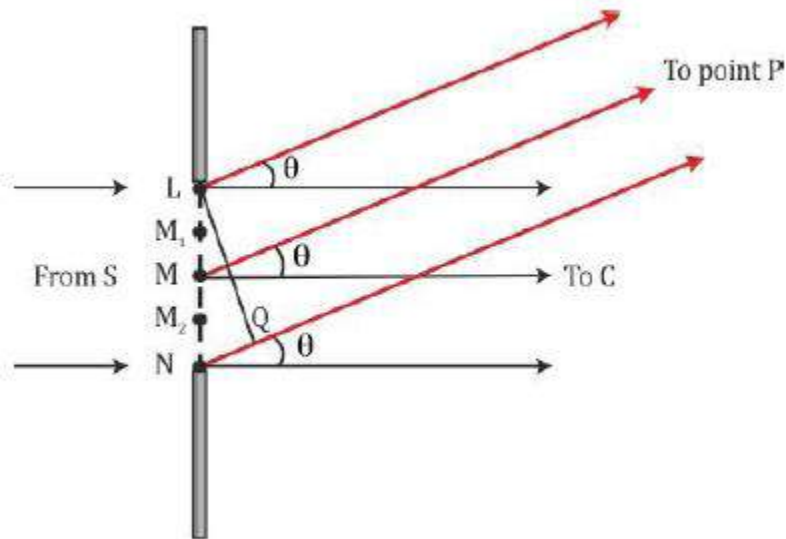

Consider that a monochromatic source of light S, emitting light waves of wavelength  $\lambda$ . As shown in figure, a parallel beam of light is falling normally on a single slit LN of width  $a$ . M is midpoint of the slit.

The diffraction pattern is obtained on a screen lying at a distance D from the slit.

The path difference between the two edges of the slit is given as,

$$\begin{aligned} \text{Path difference} &= NP - LN \\ &= NQ \\ &= a \sin \theta \\ &\approx a\theta \quad (\because \theta \text{ is very small}) \end{aligned}$$

It is observed that, the diffraction pattern has a central maximum at C flanked by a number of dark and light fringes called secondary maxima and minima on either side of the point C.

Intensity has a central maximum at  $\theta = 0$ .

The angle  $\theta$  is zero at the central point C on the screen. At C all the path differences are zero and hence all the parts of the slit contribute in phase.

Consider the angle  $\theta$  for which the path difference  $a\theta$  is  $\lambda$ .

$$\theta \approx \frac{\lambda}{a} \quad \dots\dots(1)$$

Now, divide the slit into two equal halves LM and MN each of size  $a/2$ .

For every point  $M_1$  in LM, there is a point  $M_2$  in MN such that  $M_1 M_2 = a/2$ .

The path difference between  $M_1$  and  $M_2$  at P

$$= M_2P - M_1P$$

$$= \frac{a\theta}{2}$$

$$= \frac{\lambda}{2}$$

This means that the contributions from  $M_1$  and  $M_2$  are  $180^\circ$  out of phase. Hence, contributions from the two halves of the slit LM and MN cancel each other and the intensity falls to zero for that particular chosen angle.

Similarly, the intensity is zero for  $\theta \approx \frac{n\lambda}{a}$ , with  $n$  being any integer except zero.

Now, consider an angle  $\theta = \frac{3\lambda}{2a}$  which is midway between two of the dark fringes. Divide the slit into three equal parts. If we take the first two thirds of the slit, the path difference between the two ends would be,

$$\frac{2}{3}a \times \theta = \frac{2a}{3} \times \frac{3\lambda}{2a} = \lambda$$

The first two – thirds of the slit can therefore be divided into two halves which have a  $\frac{\lambda}{2}$  path difference. The contributions of these two halves cancel each other. Only the remaining one – third of the slit contributes to the intensity at a point between the two minima which will be much weaker than the central maxima.

Similarly, it can be shown that there are maxima at  $\theta \approx \left(n + \frac{1}{2}\right) \frac{\lambda}{a}$ .

The intensity of the secondary maxima goes on decreasing with the order of maxima.

**Condition for secondary minima:**

$$\theta \approx \frac{n\lambda}{a}; \quad n = \pm 1, \pm 2, 3, \dots$$

**Condition for secondary maxima:**

$$\theta \approx \left(n + \frac{1}{2}\right) \frac{\lambda}{a}; \quad n = \pm 1, \pm 2, 3, \dots$$

(b)

Distance between the  $n^{\text{th}}$  secondary maximum from the center of the screen is given as,

$$y_n = \left(n + \frac{1}{2}\right) \frac{D\lambda}{a} = \frac{(2n+1)D\lambda}{2a}$$

For the first maxima,



$$Y_1 = \frac{3D\lambda}{2a} (\because n = 1)$$

$$\lambda_1 \text{ 90 nm} = 9000 \times 10^{-10} \text{ m}$$

$$\lambda_2 \text{ 596 nm} = 5960 \times 10^{-10} \text{ m}$$

$$D = 1.5 \text{ m}$$

$$a = 2 \times 10^{-6} \text{ m}$$

$$y_1 (\lambda_1 = 590 \text{ nm})$$

$$= \frac{3D\lambda_1}{2a}$$

$$= \frac{3 \times 1.5 \times 5900 \times 10^{-10}}{2 \times 2 \times 10^{-6}}$$

$$= 0.6637 \text{ m}$$

$$y_1 (\lambda_2 = 596 \text{ nm})$$

$$= \frac{3D\lambda_2}{2a}$$

$$= \frac{3 \times 1.5 \times 5960 \times 10^{-10}}{2 \times 2 \times 10^{-6}}$$

$$= 0.6705 \text{ m}$$

Hence, separation between the positions of first maxima of the diffraction pattern obtained in the two wavelengths is

$$= 0.6705 - 0.6637$$

$$= 0.0068 \text{ m}$$

$$= 6.8 \text{ mm}$$

29. (a) Consider a particle of charge  $q$  and mass  $m$  revolving in a circular path in the presence of magnetic field of strength  $B$ .  
The radius of the path is  $r$  and its speed of revolution is  $v$ .  
Now, the centripetal force necessary for circular motion is provided by the Lorentz force on charge  $q$  due to  $B$ .

$$F_c = F_L$$

$$\frac{mv^2}{r} = qvB$$

$$\therefore r = \frac{mv}{qB}$$

Now, the time required to traverse the entire circle is

$$T = \frac{2\pi}{\omega} = \frac{2\pi}{v/r} = \frac{2\pi r}{v}$$

$$T = \frac{2\pi}{v} \times \frac{mv}{qB} = \frac{2\pi m}{qB}$$

Thus, the frequency of revolution of the charged particle is

$$\nu_c = \frac{1}{T} = \frac{qB}{2\pi m}$$

Hence, from the above expression, we can see that the frequency of revolution of a charged particle in a magnetic field is independent of velocity or energy of the charged particle.

(b) The schematic diagram of a cyclotron is shown below.

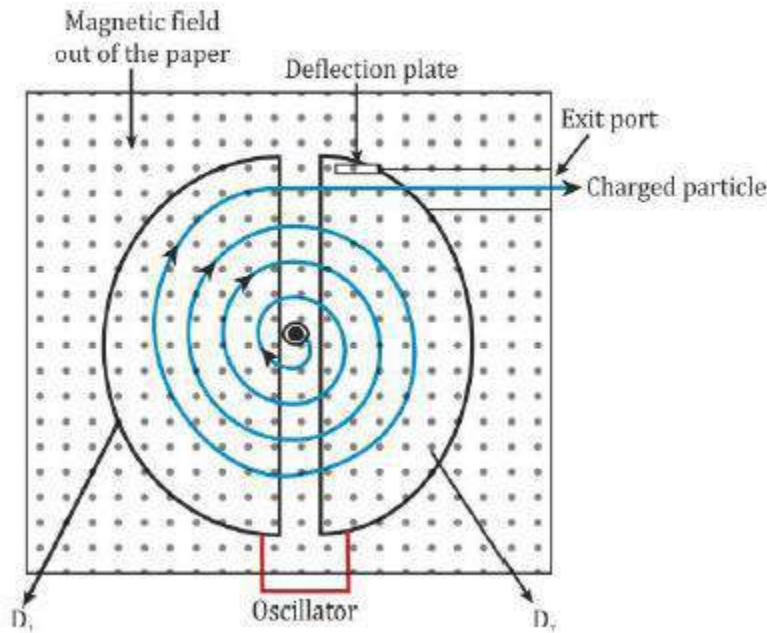

**Construction:**

A cyclotron consists of two D-shaped semicircular hollow metallic chambers called 'dees'. The two dees are placed horizontally with a small gap separating them. The two dees are connected to a source of high frequency electric field. The whole apparatus is

placed between two poles of a strong electromagnet with the field perpendicular to the plane of the dees.

Consider a positive ion produced at the centre of the gap at the time when dee D<sub>1</sub> is at positive potential and dee D<sub>2</sub> is at negative potential. The positive ion moves from dee D<sub>1</sub> to D<sub>2</sub>.

As the magnetic field acts normally to the motion of positive ion, the ion experiences force. The force on the positive ion due to magnetic field provides the centripetal force

to the ion and it deflects along a circular path.

After moving along the semicircular path inside D2, the ion reaches the gap. At this stage the polarity of the dees reverses due to alternating electric field. The positive ion gains energy as it is attracted towards D1. After traversing the path along D1, the ion again reaches the gap and gets attracted by D2 as the polarity is reversed again. Hence, the ion gains energy again. This process repeats and at each stage the particle is accelerated.

OR

(a)

### Moving coil galvanometer

**Principle:** A current carrying coil suspended in a magnetic field experiences a torque.

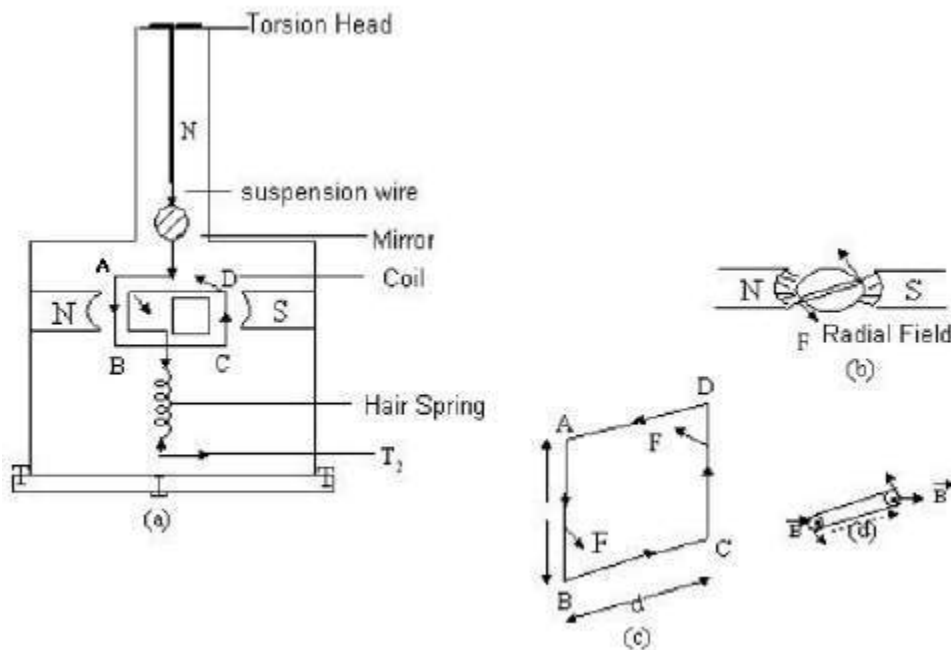

**Working:** When current is passed say long ABCD, the couple acts on it. AB experiences outward force and CD, the inward force in accordance with Fleming's left hand rule. Since the plane remains always parallel to the magnetic field in all position of the coil (radial field), the forces on the vertical arms always remains perpendicular to the plane of the coil.

Let  $I$  = the current flowing through coil.

$B$  = magnetic field supposed to be uniform and always parallel to the coil.

$l$  = length of the coil

$b$  = breadth of the coil

$N$  = no. of turns in the coil

Deflecting torque acting on the coil is

$$\tau = NIBl\sin 90^\circ = NIBlb \times 1 = NIBA$$

where  $A = lb$  = area of the coil.

Due to deflecting torque, the coil rotates and suspension wire gets twisted. A restoring torque is set up in the suspension wire. If  $\theta$  is angle through which the coil rotates and  $k$  is the restoring torque per unit angular twist (torsional constant), then Restoring torque,  $\tau = k\theta$

In equilibrium,

Deflecting torque = Restoring torque

$$NIBA = k\theta$$

$$\text{Or, } I = \left( \frac{k}{NBA} \right) \theta = G\theta$$

Where  $G = k/NBA$ , is the galvanometer constant.

$$\therefore I \propto \theta$$

This provides a linear scale for the galvanometer.

(b) (i) To produce radial magnetic field, pole pieces of a permanent magnet are made cylindrical and a soft iron core is placed between them. The soft iron core helps in making the field radial and reduces energy losses due to eddy currents.

(ii) The voltage sensitivity as deflection per unit voltage is given as

$$\frac{\phi}{I} = \left( \frac{NAB}{k} \right) \frac{1}{R}$$

The current sensitivity is given as

$$\frac{\phi}{I} = \frac{NAB}{k}$$

When we double the number of turns,  $N \rightarrow 2N$ , then we get

$$\frac{\phi}{I} \rightarrow 2 \frac{\phi}{I}$$

Thus, the current sensitivity doubles. However the resistance of the galvanometer also doubles as resistance is directly proportional to length. So the voltage sensitivity remains unchanged

$$\frac{\phi}{V} \rightarrow \left( \frac{2NAB}{k} \right) \left( \frac{1}{2R} \right) \rightarrow \frac{\phi}{V}$$

Hence, increasing the current sensitivity does not increase the voltage sensitivity.

30.

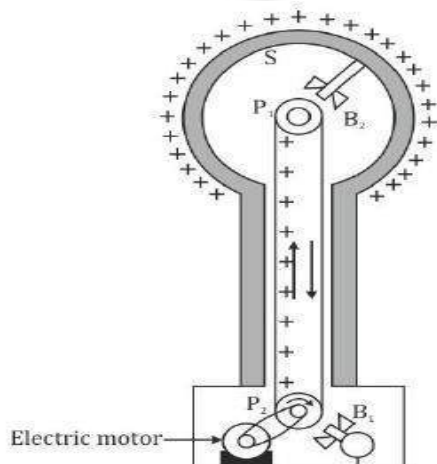

**Principle:**

- 1) The charge always resides on the outer surface of hollow conductor.
- 2) The electric discharge in air or gas takes place readily at the pointed ends of the conductors.

**Construction:**

It consists of a large hollow metallic sphere  $S$  mounted on two insulating columns and an endless belt made up of rubber which is running over two pulleys  $P^1$  and  $P^2$  with the help of an electric motor.

$B^1$  and  $B^2$  are two sharp metallic brushes. The lower brush  $B^1$  is given a positive potential by high tension battery and is called a spray brush, while the upper brush  $B^2$  is connected to the inner part of the sphere  $S$ .

**Working:**

When brush  $B_1$  is given a high positive potential then it produces ions due to the action of sharp points. Thus, the positive ions so produced get sprayed on the belt due to repulsion between positive ions and the positive charge on brush  $B_1$ . Then it is carried upward by the moving belt.

The pointed end of  $B_2$  just touches the belt, collects the positive charge and makes it move to the outer surface of the sphere  $S$ . This process continues and the potential of the shell rises to several million volts.

**Uses:**

- (1) It can be used to separate different charges.
- (2) It can be used to accelerate particles like protons,  $\alpha$  particles, etc. to high speeds and energies.

**Limitations:**

- (1) It cannot be used to generate potential more than 7 million volts.
- (2) There is only one sided movement available for the charges due to series connection.

**OR**

(a) Consider an electric dipole placed in uniform electric field  $E$ . The axis of dipole makes an angle  $\theta$  with the direction electric field.

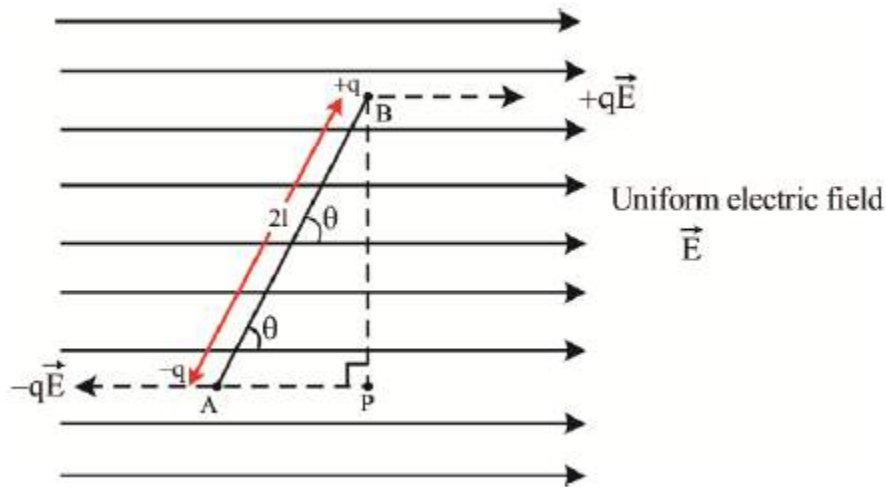

The force acting on charge +q at B is  $+q\vec{E}$  in the direction of  $\vec{E}$  and the force acting on charge -q at A is  $-q\vec{E}$  in the direction opposite to  $\vec{E}$ .

These two equal, opposite and parallel non-collinear forces separated by perpendicular distance BP acting on the electric dipole forms a couple.

The torque on the dipole is given as

$\tau$  = Magnitude of force perpendicular distance between two parallel forces

$$= qE \times BP$$

$$= qE \times 2l \sin\theta$$

$$= pE \sin \theta$$

$$\because p = q \times 2l$$

Thus, in vector form, we have

$$\vec{\tau} = \vec{p} \times \vec{E}$$

(b) (i) Let  $\Phi_1$  and  $\Phi_2$  be the electric flux through the spheres  $S_1$  and  $S_2$  respectively. Then,

$$\phi_1 = \frac{2Q}{\epsilon_0} \quad \dots\dots(1)$$

$$\phi_2 = \frac{2Q + 4Q}{\epsilon_0} = \frac{6Q}{\epsilon_0} \quad \dots\dots(2)$$

From (1) and (2), we get the ratio of the electric flux passing through the spheres  $S_1$  and  $S_2$  as

$$\frac{\phi_1}{\phi_2} = \frac{\left(\frac{2Q}{\epsilon_0}\right)}{\frac{6Q}{\epsilon_0}} = \frac{2}{6}$$

$$\phi_1 : \phi_2 = 2 : 6$$

(ii) Let  $\vec{E}$  be the electric field intensity on the surface of the sphere  $S_1$  due to the charge

2Q present inside the sphere. Then, according to Gauss' theorem, we have

$$\phi_1 = \oint \vec{E} \cdot d\vec{s} = \frac{2Q}{\epsilon_0}$$

On introducing a medium of dielectric constant  $\epsilon_r$  inside the sphere S1, suppose that electric field becomes  $\vec{E}'$ . Then, we have

$$\vec{E}' = \frac{\vec{E}}{\epsilon_r},$$

The electric flux through the sphere is now  $\Phi_1'$ , then we have

$$\phi_1' = \oint \vec{E}' \cdot d\vec{s} = \oint \frac{1}{\epsilon_r} \vec{E} \cdot d\vec{s} = \frac{2Q}{\epsilon_r \epsilon_0}$$

Thus if a medium of dielectric constant  $\epsilon_r$  is introduced in the space S1 instead of air the electric flux through the sphere S1 becomes  $\frac{2Q}{\epsilon_r \epsilon_0}$ .

