

JEE Main 2020 Paper



Date of Exam: 9th January (Shift II)

Time: 2:30 pm – 5:30 pm

Subject: Physics

1. An electron gun is placed inside a long solenoid of radius R on its axis. The solenoid has $n \frac{\text{turns}}{\text{length}}$ and carries a current i . The electron gun shoots an electron along the radius of solenoid with speed v . If the electron does not hit the surface of the solenoid, maximum possible value of v is (all symbols have their standard meaning):

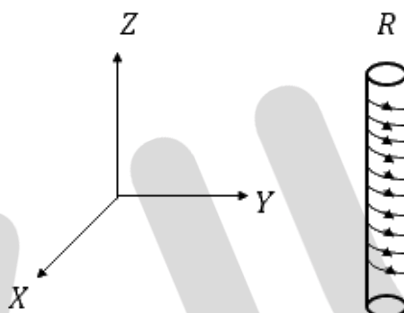

- a. $\frac{2Re\mu_0in}{m}$
c. $\frac{Re\mu_0in}{m}$

- b. $\frac{Re\mu_0in}{2m}$
d. $\frac{Re\mu_0in}{4m}$

Solution: (b)

Looking at the cross-section of the solenoid, R_{max} of the particle's motion has to be $\frac{R}{2}$ for it not to strike the solenoid.

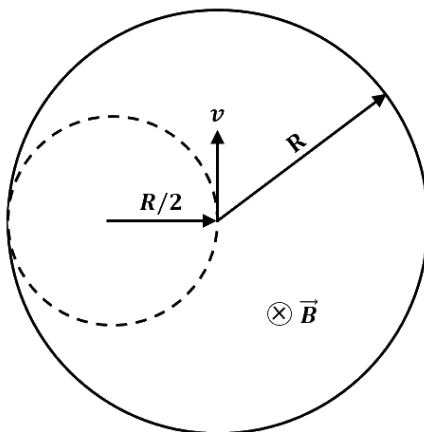

$$evB = \frac{mv^2}{\frac{R}{2}}$$

$$R_{max} = \frac{R}{2} = \frac{mv_{max}}{e\mu_0 in}$$

$$V_{max} = \frac{Re\mu_0 in}{2m}$$

2. Two identical capacitors A and B , charged to the same potential $5V$ are connected in two different circuit as shows below at time $t = 0$. If the charges on capacitors A and B at time $t = CR$ is Q_A and Q_B respectively, then (Here e is the base of natural logarithm)

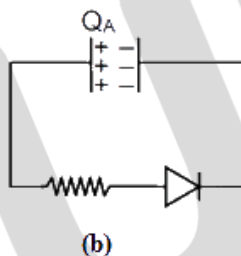
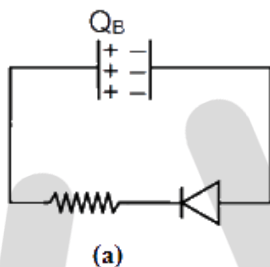

- a. $CV, \frac{CV}{e}$
 c. $\frac{CV}{e}, \frac{VC}{2}$

- b. $\frac{CV}{e}, \frac{CV}{2e}$
 d. $\frac{CV}{e}, CV$

Solution: (a)

Charge on capacitor = CV

(b) is forward biased and (a) is reverse biased

For case (b)

$$q = q_{max}(1 - e^{\frac{-t}{RC}}) = CV$$

For case (a)

$$Q_B = CVe^{-1}$$

$$Q_A = CV$$



3. For the four sets of three measured physical quantities as given below. Which of the following options is correct?

- (i) $A_1 = 24.36, B_1 = 0.0724, C_1 = 256.2$
- (ii) $A_2 = 24.44, B_2 = 16.08, C_2 = 240.2$
- (iii) $A_3 = 25.2, B_3 = 19.2812, C_3 = 236.183$
- (iv) $A_4 = 25, B_4 = 236.191, C_4 = 19.5$

- | | |
|---|--|
| <p>a. $A_4 + B_4 + C_4 < A_1 + B_1 + C_1 =$
$A_2 + B_2 + C_2 = A_3 + B_3 + C_3$</p> <p>c. $A_1 + B_1 + C_1 < A_3 + B_3 + C_3 <$
$A_2 + B_2 + C_2 < A_4 + B_4 + C_4$</p> | <p>b. $A_1 + B_1 + C_1 = A_2 + B_2 + C_2 =$
$A_3 + B_3 + C_3 = A_4 + B_4 + C_4$</p> <p>d. $A_4 + B_4 + C_4 < A_1 + B_1 + C_1 <$
$A_3 + B_3 + C_3 < A_2 + B_2 + C_2$</p> |
|---|--|

Solution: (a)

$$\begin{aligned}
 A_1 + B_1 + C_1 &= 280.632 \\
 A_2 + B_2 + C_2 &= 280.72 \\
 A_3 + B_3 + C_3 &= 280.664 \\
 A_4 + B_4 + C_4 &= 280.691
 \end{aligned}$$

Hence, option (a) is correct.

4. A particle starts from the origin at $t = 0$ with an initial velocity of $\vec{u} = 3\hat{i}$ from origin and moves in the x-y plane with a constant acceleration $\vec{a} = (6\hat{i} + 4\hat{j}) \text{ m/s}^2$. The x-coordinate of the particle at the instant when its y - coordinated is 32 m is D meters. The value of D is:

- | | |
|-------|-------|
| a. 60 | b. 50 |
| c. 32 | d. 40 |

Solution: (a)

$$\begin{aligned}
 S_y &= u_y t + \frac{1}{2} a_y t^2 \\
 32 &= 0 + \frac{1}{2} \times 4t^2 \quad \rightarrow \quad t = 4 \text{ sec} \\
 S_x &= u_x t + \frac{1}{2} a_x t^2
 \end{aligned}$$

$$= 3 \times 4 + \frac{1}{2} \times 6 \times 16$$

$$= 60 \text{ m}$$

5. A spring mass system (mass m , spring constant k and natural length l) rest in equilibrium on a horizontal disc. The free end of the spring is fixed at the center of the disc. If the disc together with spring mass system, rotates about its axis with an angular velocity ω ($k \gg m\omega^2$), the relative change in the length of the spring is best given by the option :

a. $\frac{m\omega^2}{3k}$

b. $\sqrt{\frac{2}{3}} \left(\frac{m\omega^2}{k} \right)$

c. $\frac{m\omega^2}{k}$

d. $\frac{2m\omega^2}{k}$

Solution: (c)

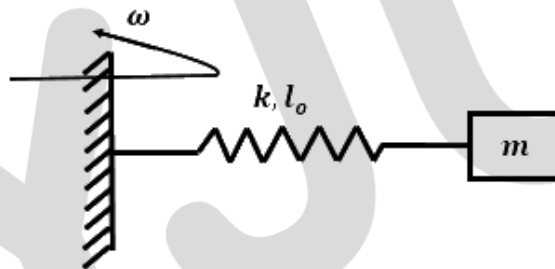

Using Newton's second law of dynamics,

$$m\omega^2(l_0 + x) = kx$$

$$\left(\frac{l_0}{x} + 1 \right) = \frac{k}{m\omega^2}$$

$$x = \frac{l_0 m \omega^2}{k - m \omega^2}$$

$$k \gg m \omega^2$$

So, $\frac{x}{l_0}$ is equal to $\frac{m\omega^2}{k}$

6. A small circular loop of conducting wire has radius a and carries current i . It is placed in a uniform magnetic field B perpendicular to its plane such that when rotated slightly about its diameter and released, it starts performing simple harmonic motion of time period T . If the mass of the loop is m then :

a. $T = \sqrt{\frac{\pi M}{iB}}$

b. $T = \sqrt{\frac{2\pi M}{iB}}$

c. $T = \sqrt{\frac{\pi M}{2iB}}$

d. $T = \sqrt{\frac{2M}{iB}}$

Solution: (b)

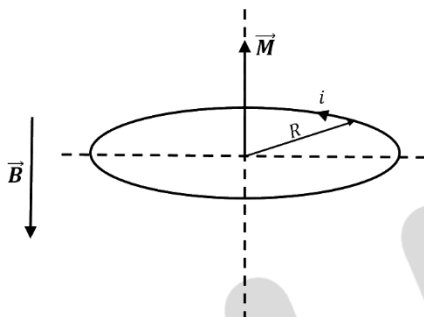

Considering the torque situation on the loop,

$$\tau = MB \sin \theta = -I\alpha$$

$$\pi R^2 i B \theta = -\frac{mR^2}{2} \alpha$$

The above equation is analogous to $\theta = -C\alpha$, where $C = \omega^2 = \frac{2\pi iB}{M}$

$$\omega = \sqrt{\frac{2\pi iB}{M}} = \frac{2\pi}{T}$$

$$T = \sqrt{\frac{2\pi M}{iB}}$$

7. A small spherical droplet of density d is floating exactly half immersed in a liquid of density ρ and surface tension T . The radius of droplet is (take note that the surface tension applied an upward force on droplet)

a. $r = \sqrt{\frac{2T}{3(\rho+d)g}}$

b. $r = \sqrt{\frac{T}{(\rho+d)g}}$

c. $r = \sqrt{\frac{T}{(d-\rho)g}}$

d. $r = \sqrt{\frac{3T}{(2d-\rho)g}}$

Solution: (d)

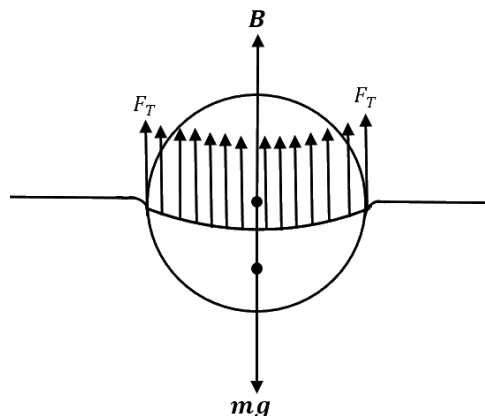

In equilibrium, net external force acting on the sphere is zero.

$$mg = F_T + B$$

$$\rho Vg = d \left(\frac{V}{2} \right) g + T2\pi R$$

$$\rho \frac{4}{3} \pi R^3 g = d \frac{2}{3} \pi R^3 g + T2\pi R$$

$$R = \sqrt{\frac{3T}{(2d - \rho)g}}$$

8. A wire of length L and mass per unit length $6 \times 10^{-3} \text{ kg/m}$ is put under tension of 540 N . Two consecutive frequencies that it resonates at are: 420 Hz and 490 Hz . Then L in meter is
- | | |
|----------|----------|
| a. 8.1 m | b. 2.1 m |
| c. 1.1 m | d. 5.1 m |

Solution: (b)

Key Idea: The difference of two consecutive resonant frequencies is the fundamental resonant frequency.

$$\text{Fundamental frequency} = 490 - 420 = 70 \text{ Hz}$$

$$70 = \frac{1}{2l} \sqrt{\frac{T}{\mu}}$$



$$\Rightarrow 70 = \frac{1}{2l} \sqrt{\frac{540}{6 \times 10^{-3}}}$$

$$\Rightarrow l = \frac{1}{2 \times 70} \sqrt{90 \times 10^{-3}} = \frac{300}{140}$$

$$\Rightarrow l \approx 2.1 \text{ m}$$

9. A plane electromagnetic wave is propagating along the direction $\frac{i+j}{\sqrt{2}}$, with the polarization along the direction \hat{k} . The correct form of the magnetic field of the wave would be (here B_0 is an appropriate constant)

a. $B_0 \frac{i-j}{\sqrt{2}} \cos\left(\omega t - k\left(\frac{i+j}{\sqrt{2}}\right)\right)$ b. $B_0 \frac{i+j}{\sqrt{2}} \cos\left(\omega t + k\left(\frac{i+j}{\sqrt{2}}\right)\right)$
 c. $B_0 \frac{j-i}{\sqrt{2}} \cos\left(\omega t + k\left(\frac{i+j}{\sqrt{2}}\right)\right)$ d. $B_0 \hat{k} \cos\left(\omega t - k\left(\frac{i+j}{\sqrt{2}}\right)\right)$

Solution: (a)

EM wave is in direction $\frac{i+j}{\sqrt{2}}$

Electric field is in direction \hat{k}

Direction of propagation of EM wave is given by $\vec{E} \times \vec{B}$

10. Two gases-Argon (atomic radius 0.07 nm , atomic weight 40) and Xenon (atomic radius 0.1 nm , atomic weight 140) have the same number density and are at the same temperature. The ratio of their respective mean free time is closest to

a. 4.67 b. 2.04
 c. 1.83 d. 3.67

Solution: (challenge question)

$$\text{Mean free time} = \frac{1}{\sqrt{2} n \pi d^2}$$

$$\frac{t_{Ar}}{t_{Xe}} = \frac{d_{Xe}^2}{d_{Ar}^2} = \left(\frac{0.1}{0.07}\right)^2 = \left(\frac{10}{7}\right)^2 = 2.04$$

11. Two steel wires having same length are suspended from a ceiling under the same load. If the ratio of their energy stored per unit volume is 1: 4, the ratio of their diameters is:

a. $\sqrt{2}: 1$ b. $1:\sqrt{2}$
 c. 1:2 d. 2:1



Solution: (a)

$$\begin{aligned} \frac{dU}{dV} &= \frac{1}{2} \times stress \times \frac{stress}{Y} \\ &= \frac{1}{2} \times \frac{F^2}{A^2 Y} \\ \frac{dU}{dV} &\propto \frac{1}{D^4} \\ \left(\frac{dU}{dV}\right)_1 &= \frac{D_2^4}{D_1^4} = \frac{1}{4} \\ \frac{D_1}{D_2} &= (4)^{\frac{1}{4}} \end{aligned}$$

$$\therefore D_1 : D_2 = \sqrt{2} : 1$$

12. Planets A has a mass M and radius R . Planet B has the mass and half the radius of planet A . If the escape velocities from the planets A and B are v_A and v_B respectively, then surfaces is $\frac{v_A}{v_B} = \frac{n}{4}$, the value of n is :

- a. 3 b. 2
- c. 4 d. 5

Solution: (c)

We know that the escape velocity is given by,

$$V_e = \sqrt{\frac{2GM}{R}}$$

Now,

$$\frac{V_1}{V_2} = \frac{\sqrt{\frac{2GM}{R}}}{\sqrt{\frac{2GM}{\frac{R}{2}}}} = 1$$

We are given that $\frac{v_1}{v_2} = \frac{n}{4}$

$$\begin{aligned} \Rightarrow \frac{n}{4} &= 1 \\ \Rightarrow n &= 4 \end{aligned}$$

13. A rod of length L has non-uniform linear mass density given by $\rho(x) = \left(a + b \left(\frac{x}{L}\right)^2\right)$, Where a and b are constants and $0 \leq x \leq L$. The value of x for the center of mass of the rod is at :

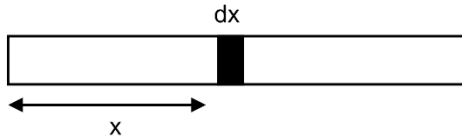

- a. $\frac{3L}{2} \left(\frac{2a+b}{3a+b}\right)$ b. $\frac{3L}{4} \left(\frac{2a+b}{3a+b}\right)$
 c. $\frac{3L}{4} \left(\frac{a+b}{3a+b}\right)$ d. $\frac{4L}{3} \left(\frac{a+b}{3a+b}\right)$

Solution: (b)

Here we take a small element along the length as dx at a distance x from the left end as shown.

$$\begin{aligned}
 x_{cm} &= \frac{1}{M} \int_0^L x \cdot dm \\
 \Rightarrow dM &= \lambda \cdot dx = \left(a + b \left(\frac{x}{L}\right)^2\right) \cdot dx \\
 x_{cm} &= \frac{\int x \lambda dx}{\int \lambda dx} = \frac{\int_0^L x \left(a + \frac{bx^2}{L^2}\right) dx}{\int_0^L \left(a + \frac{bx^2}{L^2}\right) dx} \\
 &= \frac{a \left(\frac{x^2}{2}\right)_0^L + \frac{b}{L^2} \left(\frac{x^4}{4}\right)_0^L}{a(x)_0^L + \frac{b}{L^2} \left(\frac{x^3}{3}\right)_0^L} \\
 &= \frac{\frac{aL^2}{2} + \frac{bL^2}{4}}{aL + \frac{bL}{3}} \\
 &= \frac{3L}{4} \left(\frac{2a+b}{3a+b}\right)
 \end{aligned}$$

14. A particle of mass m is projected with a speed u from the ground at angle $\theta = \frac{\pi}{3}$ is w.r.t. horizontal (x -axis). When it has reached its maximum height, it collides completely inelastically with another particle of the same mass and velocity $u \hat{i}$. The horizontal distance covered by the combined mass before reaching the ground is :

a. $\frac{3\sqrt{3}u^2}{8g}$

b. $\frac{2\sqrt{2}u^2}{g}$

c. $\frac{5u^2}{8g}$

d. $\frac{3\sqrt{2}u^2}{4g}$

Solution: (a)

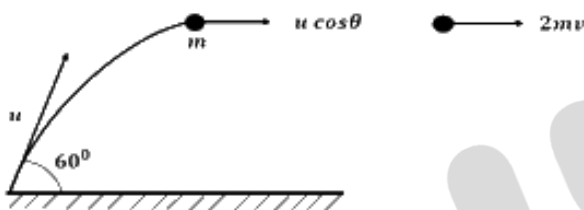

The only external force acting on the colliding system during the collision is the gravitational force. Since gravitational force is non-impulsive, the linear momentum of the system is conserved just before and just after the collision.

$$p_i = p_f$$

$$mu + mu \cos\theta = 2mv$$

$$\Rightarrow v = \frac{u(1 + \cos 60^\circ)}{2} = \frac{3}{4}u$$

So the horizontal range after the collision = vt

$$= v \sqrt{\frac{2H_{\max}}{g}}$$

$$= \frac{3}{4}u \sqrt{\frac{2u^2 \sin^2 60^\circ}{2g^2}}$$

$$= \frac{3}{4}u^2 \frac{\sqrt{\frac{3}{4}}}{g} = \frac{3\sqrt{3}u^2}{8g}$$

15. A uniformly thick wheel with moment of inertia I and radius R is free to rotate about its center of mass (see fig). A massless string is wrapped over its rim and two blocks of masses m_1 and m_2 ($m_1 > m_2$) are attached to the ends of string. The system is released from rest. The angular speed of the wheel when m_1 descend by a distance h is :

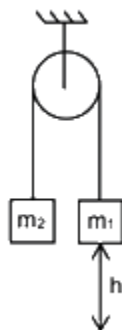

a. $\frac{1}{R} \sqrt{\frac{2(m_1 - m_2)gh}{(m_1 + m_2) + \frac{I}{R^2}}}$

b. $\frac{gh}{R} \sqrt{\frac{(m_2 + m_1)}{m_1 + m_2 + \frac{I}{R^2}}}$

c. $\frac{gh}{R} \sqrt{\frac{(m_1 - m_2)}{m_1 + m_2 + \frac{I}{R^2}}}$

d. $\frac{1}{R} \sqrt{\frac{2(m_2 + m_1)gh}{m_1 + m_2 + \frac{I}{R^2}}}$

Solution: (a)

Assume initial potential energy of the blocks to be zero. Initial kinetic energy is also zero since the blocks are at rest.

When block m_1 falls by h , m_2 goes up by h (because of length constraint)

Final P.E = $m_2gh - m_1gh$

Let the final speed of the blocks be v and angular velocity of the pulley be ω

Final K.E = $\frac{1}{2}(m_1 + m_2)v^2 + \frac{1}{2}I\omega^2$

Total energy is conserved. Hence,

$$0 = m_2gh - m_1gh + \frac{1}{2}(m_1 + m_2)v^2 + \frac{1}{2}I\omega^2$$

$v = \omega r$ (due to no slip condition)

$$\Rightarrow \frac{1}{2}(m_1 + m_2)\omega^2 R^2 + \frac{1}{2}I\omega^2 = (m_1 - m_2)gh$$

$$\Rightarrow \omega^2 \left[\frac{1}{2}(m_1 + m_2)R^2 + \frac{1}{2}I \right] = (m_1 - m_2)gh$$

$$\Rightarrow \omega^2 = \frac{2(m_1 - m_2)gh}{R^2 \left[(m_1 + m_2) + \frac{I}{R^2} \right]}$$

$$\Rightarrow \omega = \frac{1}{R} \sqrt{\frac{2(m_1 - m_2)gh}{\left[(m_1 + m_2) + \frac{I}{R^2} \right]}}$$



16. The energy required to ionise a hydrogen like ion in its ground state is 9 Rydbergs. What is the wavelength of the radiation emitted when the electron in this ion jumps from the second excited state to the ground state ?
- | | |
|---------|---------|
| a. 8.6 | b. 11.4 |
| c. 24.2 | d. 35.8 |

Solution: (b)

$$\frac{hc}{\lambda} = (13.6 \text{ eV})Z^2 \left(\frac{1}{n_1^2} - \frac{1}{n_2^2} \right)$$

$$n_1 = 1$$

$$n_2 = 3$$

For an H-like atom, ionization energy is $(R)Z^2$.

This gives $Z = 3$

$$\frac{hc}{\lambda} = (13.6 \text{ eV})(3^2) \left(\frac{1}{1^2} - \frac{1}{3^2} \right)$$

$$\Rightarrow \frac{hc}{\lambda} = (13.6 \text{ eV})(9) \times \frac{8}{9}$$

$$\text{Wavelength} = \frac{1240}{8 \times 13.6} \text{ nm}$$

$$\lambda = 11.4 \text{ nm}$$

17. There is a small source of light at some depth below the surface of water (refractive index $\frac{4}{3}$) in a tank of large cross sectional surface area. Neglecting any reflection from the bottom and absorption by water, percentage of light that emerges out of surface is (nearly): [Use the fact that surface area of a spherical cap of height h and radius of curvature r is $2\pi rh$]
- | | |
|---------|---------|
| a. 17 % | b. 34 % |
| c. 50 % | d. 21 % |

Solution: (a)

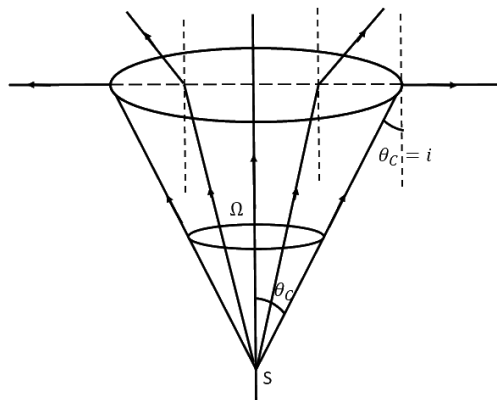

The portion of light escaping into the air from the liquid will form a cone. As long as the angle of incidence on the liquid – air interface is less than the critical angle, i.e. $i < \theta_c$, the light rays will undergo refraction and emerge into the air.

For $i > \theta_c$, the light rays will suffer TIR. So, these rays will not emerge into the air.

The portion of light rays emerging into the air from the liquid will form a cone of half angle = θ_c

$$\sin \theta_c = \frac{1}{\mu_{Liq}} = \frac{3}{4}, \quad \cos \theta_c = \frac{\sqrt{7}}{4}$$

Solid angle contained in this cone is

$$\Omega = 2\pi(1 - \cos \theta_c)$$

$$\text{Percentage of light that escapes from liquid} = \frac{\Omega}{4\pi} \times 100$$

Putting values we get

$$\text{Percentage} = \frac{4 - \sqrt{7}}{8} \times 100 \approx 17\%$$

18. An electron of mass m and magnitude of charge $|e|$ initially at rest gets accelerated by a constant electric field E . The de-Broglie wavelength of this electron at time t ignoring relativistic effects is

a. $-\frac{|e|Et}{h}$
 c. $-\frac{h}{|e|Et^2}$

b. $\frac{h}{|e|E\sqrt{t}}$
 d. $-\frac{2ht^2}{|e|E}$

Solution: (c)

$$\lambda_D = \frac{h}{mv}$$

JEE Main 2020 Paper



20. The current (i) in the network is

- a. 0 A
- c. 0.2 A

- b. 0.3 A
- d. 0.6 A

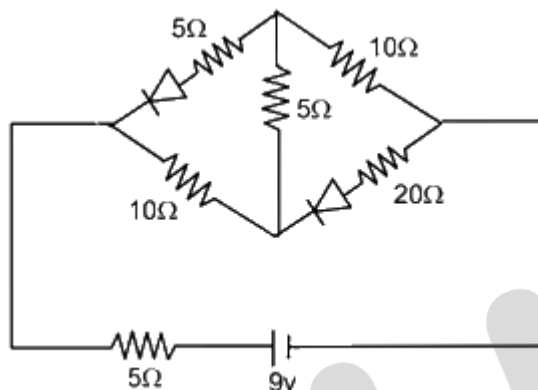

Solution: (b)

Since the diodes are reverse biased, they will not conduct.
Hence, the circuit will look like

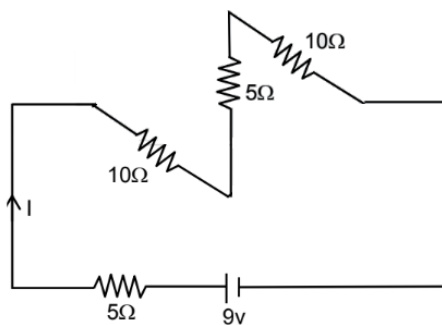

$$R_{eff} = 5 + 10 + 5 + 10 = 30\ \Omega$$

$$I = \frac{9}{30} = 0.3\text{ A}$$

JEE Main 2020 Paper



21. Starting at temperature 300 K , one mole of an ideal diatomic gas ($\gamma = 1.4$) is first compressed adiabatically from volume V_1 to $V_2 = \frac{V_1}{16}$. It is then allowed to expand isobarically to volume $2V_2$. If all the processes are the quasi-static then the final temperature of the gas ($^{\circ}\text{K}$) is (to the nearest integer)

Solution: (1818 K)

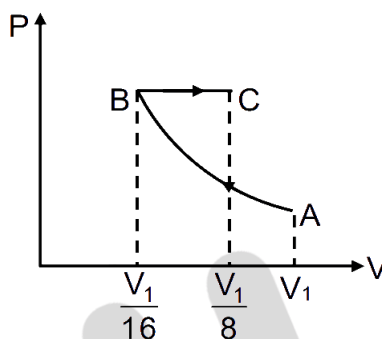

$$PV^\gamma = \text{Constant}$$
$$TV^{(\gamma-1)} = \text{constant}$$

Now for BC process

$$300(V_1)^{(1.4-1)} = T_B \left(\frac{V_1}{16}\right)^{\frac{2}{5}}$$
$$T_B = 300 \times 2^{\left(\frac{8}{5}\right)}$$
$$\frac{V_B}{T_B} = \frac{V_C}{T_C}$$
$$T_C = \frac{V_C T_B}{T_B} = 2 \times 300 \times 2^{\left(\frac{8}{5}\right)}$$
$$T_C = 1818\text{ K}$$

22. An electric field $\vec{E} = 4x\hat{i} - (y^2 + 1)\hat{j} \text{ N/C}$, passes through the box shown in figure. The flux of the electric field through surface $ABCD$ and $BCGF$ are marked as ϕ_1 and ϕ_2 , then difference between $(\phi_1 - \phi_2)$ is $(\frac{Nm^2}{C})$

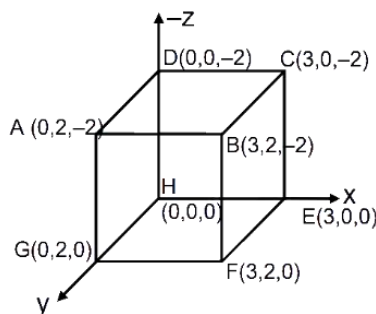

Solution: (challenge question)

Electric flux through a surface is $\phi = \int \vec{E} \cdot d\vec{A}$

For surface $ABCD$,

$d\vec{A}$ is along $(-\hat{k})$

So, at all the points of this surface,

$$\vec{E} \cdot d\vec{A} = 0$$

Because, $\phi_{ABCD} = \phi_1 = 0$

For surface $BCEF$,

$d\vec{A}$ is along (\hat{i})

So,

$$\vec{E} \cdot d\vec{A} = E_x dA$$

$$\phi_{BCEF} = \phi_2 = 4x(2 \times 2)$$

If $x = 3$

$$\phi_2 = 48 \frac{N - m^2}{C}$$

Hence, $\phi_1 - \phi_2 = -48 \frac{N - m^2}{C}$

23. In a Young's double slit experiment 15 fringes are observed on a small portion of the screen when light of wavelength 500 nm is used. 10 fringes are observed on the same section of the screen when another light source of wavelength λ is used. Then the value of λ is (nm)

Solution: (750)

JEE Main 2020 Paper



If the length of the segment is y ,

$$\text{Then } y = n \beta$$

n = no. of fringes,

β = fringe width

$$15 \times 500 \times \frac{D}{d} = 10 \times \lambda_2 \times \frac{D}{d}$$

$$\lambda_2 = 15 \times 50 \text{ nm}$$

$$\lambda_2 = 750 \text{ nm}$$

24. In a meter bridge experiment S is a standard resistance. R is a resistance wire. It is found that balancing length is $l = 25 \text{ cm}$. If R is replaced by a wire of half length and half diameter that of R of same material, then the balancing l (in cm) will now be

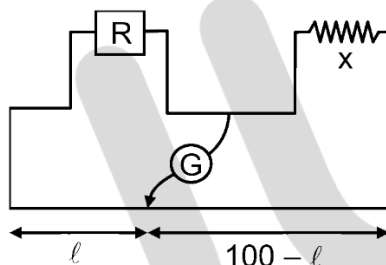

Solution: (40)

$$\frac{X}{R} = \frac{75}{25} = 3$$

$$R = \frac{\rho l}{A} = \frac{4\rho l}{\pi d^2}$$

$$R' = \frac{4\rho \frac{l}{2}}{\pi \left(\frac{d}{2}\right)^2} = 2R$$

$$\text{Then } \frac{X}{R'} = \left(\frac{100-l}{l}\right)$$

$$\frac{100-l}{l} = \frac{X}{2R} = \frac{3}{2}$$

$$l = 40.00 \text{ cm}$$

25. The circuit shown below is working as a 8 V dc regulated voltage source. When 12 V is used as input, the power dissipated (in mW) in each diode is; (considering both zener diode are identical).

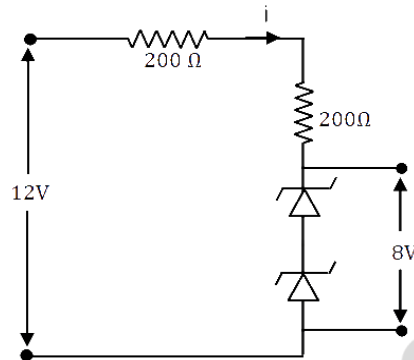

Solution: (challenge question)

$$i = \left(\frac{12-8}{200+200} \right) A = \frac{4}{400} = 10^{-2} A$$

$$\text{Power loss in each diode} = (4)(10^{-2}) W = 40 mW$$