

Exercise Questions

Page number – 205

1. 'All elements that are present in a plant need not be essential to its survival'. Comment

Solution:

No, out of 105 elements absorbed by plants only about 17 elements are essential for plant growth and survival.

2. Why is purification of water and nutrient salts so important in studies involving mineral nutrition using hydroponics?

Solution:

Hydroponics is a method of growing plants in the nutrition solution in the absence of soil. There are plenty of impurities in impure water in the form of soluble minerals that are dissolved in it. If this water is used as a solution culture to grow plants in hydroponics, these impurities will interfere with the experimental procedure used to detect the elements. Hence, pure water and purified nutrient salts are utilized in studies involving mineral nutrition using hydroponics.

3. Explain with examples: macronutrients, micronutrients, beneficial nutrients, toxic elements and essential elements.

Solution:

Macronutrients - Nutrients present in more than 10mmole kg^{-1} of dry matter in plant tissues are known as macronutrients. They are required in large amounts for plant growth. Ex: Carbon, Hydrogen, Oxygen, Nitrogen, Phosphorus, Sulphur, Potassium, calcium and magnesium.

Micronutrients - are the trace elements present in less than 10mmole kg^{-1} of dry matter in plant. Example – manganese, copper, zinc, boron, nickel

Beneficial elements - In addition to 17 essential nutrients there are some beneficial elements required by higher plants in addition to micro and macronutrients. Ex: Sodium, Silicon, Cobalt and selenium.

Toxic elements are those which are required in trace amount. Their deficiency causes diseases in plants and excess in such nutrients are toxic to plants. Ex: Sodium, Potassium, Magnesium .

Essential elements – It is an element that directly interferes in the metabolism of the plant causing a specific deficiency symptom if not available to plants from an external source.

4. Name at least five different deficiency symptoms in plants. Describe them and correlate them with the concerned mineral deficiency.

Solution:

Chlorosis: Loss of chlorophyll leading to the yellow colouration of the leaves. It is caused by the deficiency of N, K, Mg, S, Fe, Mn, Zn and Mo.

Necrosis: It is the death of leaf tissue due to deficiency of Ca, Mg, Cu, K. It is the killing of cells expressed in the form of leaf spots, rots and blights.

Inhibition of cell division: deficiency in Mo, N, K and S causes inhibition of Cell division. They are expressed in stunted growth

Delay in flowering: In some plants it is caused due to low concentration of N, S and Mo.

Deformation – It is caused due to deficiency of boron. Deformation, disorganization, discolouration of the meristematic tissue and ultimately death of a growing plant.

5. If a plant shows a symptom which could develop due to deficiency of more than one nutrient, how would you find out experimentally, the real deficient mineral element?

Solution:

Plants which show symptoms of multiple nutrient deficiency grown in different sets in water culture. Set 1, 2 and 3 are given three different nutrients and are grown in hydroponics by supplementing one of the different nutrients showing deficiency. If real deficient element is supplemented then the plant will grow normally without showing deficiency symptoms.

6. Why is that in certain plants deficiency symptoms appear first in younger parts of the plant while in others they do so in mature organs?

Solution:

Mobility of a deficient element decides the appearance of symptoms. If the element is relatively immobile then symptoms appear in young parts and if the deficient element is mobile, then symptoms appear in older parts of the plant.

7. How are the minerals absorbed by the plants?

Solution:

The process of absorption can be established in two main phases. In the first phase, an initial rapid uptake of ions occurs passively into the 'free space' or 'outer space' of cells – the apoplast. In the second phase of uptake, the ions are taken in slowly into the symplast of the cells – 'inner space'. The passive movement of ions into the apoplast usually takes place through ion-channels, the trans-membrane proteins that function as selective pores. The entry or exit of ions to and from the symplast requires the expenditure of metabolic energy and that is an active process. The movement of ions is usually called flux; the inward movement into the cells is influx and the outward movement, efflux.

8. What are the conditions necessary for fixation of atmospheric nitrogen by Rhizobium? What is their role in N_2 -fixation?

Solution:

Following conditions are necessary for fixation of Nitrogen by Rhizobium.

- Symbiotic relationship between Rhizobium and roots- necessary for the formation of root nodules.
- Necessity of a reducing environment
- Nitrogenase enzyme - synthesizes ammonia
- ATP- is required for the synthesis of ammonia
- $NAD(P)H_2$ or $FMNH_2$ is a source of reducing power
- Ferredoxin - acts as an electron donor
- Keto acids picks up amino group.
- nitrate as a substrate – creates reduced availability of nitrate

Role of Rhizobium in N_2 fixation:

- They fix atmospheric nitrogen in a form that can be used by plants i.e., ammonia, using the nitrogenase enzyme.
- Plant, in turn, delivers bacteria with proteins, carbohydrates and enough oxygen so that they do not disturb the fixation process.
- A plant protein - Leghaemoglobin assists in providing oxygen for respiration process while free oxygen concentration level is still low enough to not hinder the nitrogenase activity.

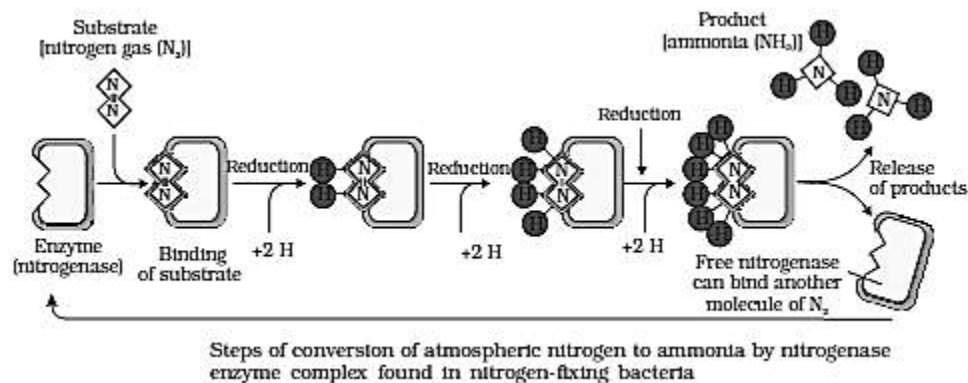

9. What are the steps involved in formation of a root nodule?

Solution:

Formation of nodules involves following steps:

- Rhizobia colonise the roots and get attached to epidermal and root hair cells.
- Bacteria invade the root hair and make it curled.
- Curling produces an infection thread which carries bacteria into the cortex of the root.

- Roots nodules are formed at the cortex of the root.
- When infected thread carries the bacteris to the inner cortex, it modifies the bacteria into rod-shaped bacteroids . It causes inner cortical and pericycle cells to undergo division. The division and growth of cortical and pericycle cells result in nodule formation
- The vascular tissue continues with that of the root, then a mature nodule is complete

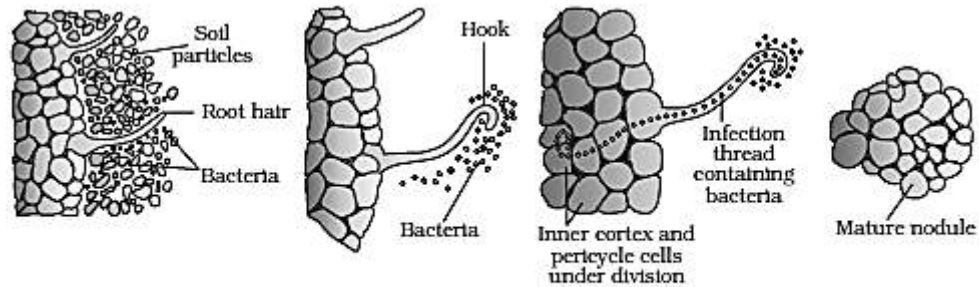

10. Which of the following statements are true? If false, correct them:

- Boron deficiency leads to stout axis.
- Every mineral element that is present in a cell is needed by the cell.
- Nitrogen as a nutrient element is highly immobile in the plants.
- It is very easy to establish the essentiality of micronutrients because they are required only in trace quantities.

Solution:

- True
- False- Every mineral element that is present in a cell is not needed by the cell.
- False- Nitrogen as a nutrient is highly mobile in plants.
- False- It is challenging to establish the essentiality of micronutrients because they are required only in trace quantities.