

**Q 2.1) Two charges  $5 \times 10^{-8} \text{ C}$  and  $-3 \times 10^{-8} \text{ C}$  are located 16 cm apart from each other. At what point (s) on the line joining the two charges is the electric potential zero? Take the potential at infinity to be zero.**

**Solution:**

Given,

$$q_1 = 5 \times 10^{-8} \text{ C}$$

$$q_2 = -3 \times 10^{-8} \text{ C}$$

The two charges are at a distance,  $d = 16\text{cm} = 0.16\text{m}$  from each other.

Let us consider a point "P" over the line joining charges  $q_1$  and  $q_2$ .

Let the distance of the considered point P from  $q_1$  be 'r'

Let us consider point P to have zero electric potential (V)..

The electric potential at point P is the summation of potentials due to charges  $q_1$  and  $q_2$ .

$$\text{Therefore, } V = \frac{1}{4\pi\epsilon_0} \cdot \frac{q_1}{r} + \frac{1}{4\pi\epsilon_0} \cdot \frac{q_2}{d-r} \dots\dots\dots(1)$$

Here,

$\epsilon_0$  = permittivity of free space.

Putting  $V = 0$ , in eqn. (1), we get,

$$0 = \frac{1}{4\pi\epsilon_0} \cdot \frac{q_1}{r} + \frac{1}{4\pi\epsilon_0} \cdot \frac{q_2}{d-r}$$

$$\frac{1}{4\pi\epsilon_0} \cdot \frac{q_1}{r} = -\frac{1}{4\pi\epsilon_0} \cdot \frac{q_2}{d-r}$$

$$\frac{q_1}{r} = -\frac{q_2}{d-r}$$

$$\frac{5 \times 10^{-8}}{r} = -\frac{(-3 \times 10^{-8})}{0.16-r}$$

$$5(0.16 - r) = 3r$$

$$0.8 = 8r$$

$$r = 0.1\text{m} = 10 \text{ cm.}$$

Therefore, at a distance of 10 cm from the positive charge, the potential is zero between the two charges.

Let us assume a point P at a distance 's' from the negative charge be outside the system, having potential zero.

So, for the above condition, the potential is given by –

$$V = \frac{1}{4\pi\epsilon_0} \cdot \frac{q_1}{s} + \frac{1}{4\pi\epsilon_0} \cdot \frac{q_2}{s-d} \dots\dots\dots(2)$$

Here,

$\epsilon_0$  = permittivity of free space.

For  $V = 0$ , eqn. (2) can be written as:

$$0 = \frac{1}{4\pi\epsilon_0} \cdot \frac{q_1}{s} + \frac{1}{4\pi\epsilon_0} \cdot \frac{q_2}{s-d}$$

$$\frac{1}{4\pi\epsilon_0} \cdot \frac{q_1}{s} = -\frac{1}{4\pi\epsilon_0} \cdot \frac{q_2}{s-d}$$

$$\frac{q_1}{s} = -\frac{q_2}{s-d}$$

$$\frac{5 \times 10^{-8}}{s} = -\frac{(-3 \times 10^{-8})}{s-0.16}$$

$$5(s - 0.16) = 3s$$

$$0.8 = 2s$$

$$S = 0.4 \text{ m} = 40 \text{ cm.}$$

Therefore, at a distance of 40 cm from the positive charge outside the system of charges, the potential is zero.

**Q 2.2) A regular hexagon of side 10 cm has a charge  $5 \mu\text{C}$  at each of its vertices. Calculate the potential at the centre of the hexagon.**

**Solution:**

The figure shows regular hexagon containing charges  $q$ , at each of its vertices.

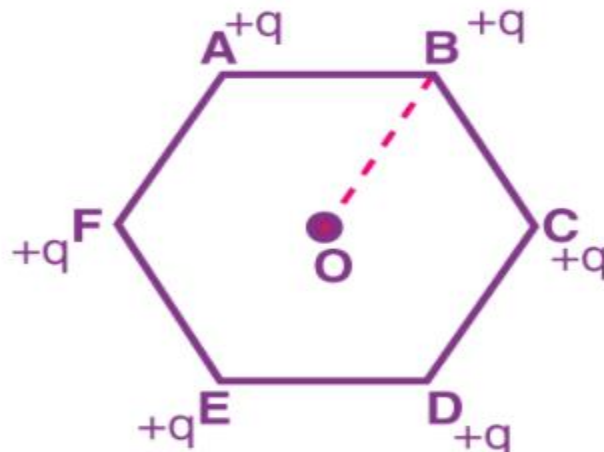

Here,

$$q = 5 \mu\text{C} = 5 \times 10^{-6} \text{ C.}$$

Length of each side of hexagon,  $AB = BC = CD = DE = EF = FA = 10 \text{ cm.}$

The distance of the vertices from the centre O,  $d = 10 \text{ cm.}$

The electric potential at point O,

$$V = \frac{1}{4\pi\epsilon_0} \cdot \frac{6q}{d}$$

Here,

$$\epsilon_0 = \text{Permittivity of free space and } \frac{1}{4\pi\epsilon_0} = 9 \times 10^9 \text{ Nm}^2\text{C}^{-2}$$

$$V = \frac{9 \times 10^9 \times 6 \times 5 \times 10^{-6}}{0.1} = 2.7 \times 10^8 \text{ V.}$$

**Q 2.3) Two charges  $2 \mu\text{C}$  and  $-2 \mu\text{C}$  are placed at points A and B, 6 cm apart.**

**(1) Identify the equipotential surface of the system.**

**(2) What is the direction of the electric field at every point on this surface?**

**Solution:**

(1) An equipotential surface is defined as the surface over which the total potential is zero. In the given question the plane is normal to line AB. The plane is located at the mid – point of the line AB as the magnitude of the charges are same.

(2) At every point on this surface the direction of the electric field is normal to the plane in the direction of AB.

**Q 2.4) A spherical conductor of radius 12 cm has a charge of  $1.6 \times 10^{-7}\text{C}$  distributed uniformly on its surface. What is the electric field**

**(1) inside the sphere.**

**(2) just outside the sphere.**

**(3) at a point 18 cm from the centre of sphere.**

**Solution:**

(1) Given,

Radius of spherical conductor,  $r = 12\text{cm} = 0.12\text{m}$

Charge is distributed uniformly over the surface,  $q = 1.6 \times 10^{-7} \text{ C.}$

The electric field inside a spherical conductor is zero.

(2) Electric field  $E$ , just outside the conductor is given by the relation,

$$E = \frac{1}{4\pi\epsilon_0} \cdot \frac{q}{r^2}$$

Here,

$$\epsilon_0 = \text{permittivity of free space and } \frac{1}{4\pi\epsilon_0} = 9 \times 10^9 \text{ Nm}^2\text{C}^{-2}$$

Therefore,

$$E = \frac{9 \times 10^9 \times 1.6 \times 10^{-7}}{(0.12)^2} = 10^5 \text{ NC}^{-1}$$

Therefore, just outside the sphere the electric field is  $10^5 \text{ NC}^{-1}$ .

(3) From the centre of the sphere the electric field at a point  $18\text{m} = E_1$ .

From the centre of the sphere, the distance of point  $d = 18 \text{ cm} = 0.18\text{m}$ .

$$E_1 = \frac{1}{4\pi\epsilon_0} \cdot \frac{q}{d^2} = \frac{9 \times 10^9 \times 1.6 \times 10^{-7}}{(1.8 \times 10^{-2})^2} = 4.4 \times 10^4 \text{ NC}^{-1}$$

So, from the centre of sphere the electric field at a point  $18 \text{ cm}$  away is  $4.4 \times 10^4 \text{ NC}^{-1}$ .

**Q 2.5) A parallel plate capacitor with air between the plates has a capacitance of  $8\text{pF}$  ( $1\text{pF} = 10^{-12} \text{ F}$ ). What will be the capacitance if the distance between the plates is reduced by half and the space between them is filled with a substance of dielectric constant  $6$ ?**

**Solution:**

Given,

Capacitance,  $C = 8\text{pF}$ .

In the first case, the parallel plates are at a distance 'd' and is filled with air.

Air has dielectric constant,  $k = 1$

$$\text{Capacitance, } C = \frac{k \times \epsilon_0 \times A}{d} = \frac{\epsilon_0 \times A}{d} \quad \dots \text{ eq(1)}$$

Here,

$A$  = area of each plate

$\epsilon_0$  = permittivity of free space.

Now, if the distance between the parallel plates is reduced to half, then  $d_1 = d/2$

Given, dielectric constant of the substance,  $k_1 = 6$

Hence, the capacitance of the capacitor,

$$C_1 = \frac{k_1 \times \epsilon_0 \times A}{d_1} = \frac{6\epsilon_0 \times A}{d/2} = \frac{12\epsilon_0 A}{d} \dots (2)$$

Taking ratios of eqns. (1) and (2), we get,

$$C_1 = 2 \times 6 C = 12 C = 12 \times 8 \text{ pF} = 96 \text{ pF}.$$

Hence, the capacitance between the plates is 96 pF.

**Q 2.6) Three capacitors connected in series have capacitance of 9 pF each.**

**(1) What is the total capacitance of the combination?**

**(2) What is the potential difference across each capacitor if the combination is connected to a 120 V supply?**

**Solution:**

(1) Given,

The capacitance of the three capacitors,  $C = 9 \text{ pF}$

Equivalent capacitance ( $C_{eq}$ ) is the capacitance of the combination of the capacitors given by

$$\frac{1}{C_{eq}} = \frac{1}{C} + \frac{1}{C} + \frac{1}{C} = \frac{3}{C} = \frac{3}{9} = \frac{1}{3}$$

$$\frac{1}{C_{eq}} = \frac{1}{3} = C_{eq} = 3 \text{ pF}$$

Therefore, the total capacitance = 3 pF.

(2) Given, supply voltage,  $V = 100 \text{ V}$

The potential difference ( $V_1$ ) across the capacitors will be equal to one – third of the supply voltage.

$$\text{Therefore, } V_1 = \frac{V}{3} = \frac{120}{3} = 40 \text{ V}.$$

Hence, the potential difference across each capacitor is 40 V.

**Q 2.7) Three capacitors of capacitances 2 pF, 3 pF and 4 pF are connected in parallel.**

**(1) What is the total capacitance of the combination?**

**(2) Determine the charge on each capacitor if the combination is connected to a 100 V supply.**

**Solution:**

(1) Given,  $C_1 = 2 \text{ pF}$ ,  $C_2 = 3 \text{ pF}$  and  $C_3 = 4 \text{ pF}$ .

Equivalent capacitance for the parallel combination is given by  $C_{eq}$ .

$$\text{Therefore, } C_{eq} = C_1 + C_2 + C_3 = 2 + 3 + 4 = 9 \text{ pF}$$

Hence, the total capacitance of the combination is 9pF.

(2) Supply voltage,  $V = 100V$

The three capacitors are having the same voltage,  $V = 100v$

$$q = VC$$

where,

$q$  = charge

$C$  = capacitance of the capacitor

$V$  = potential difference

for capacitance,  $c = 2pF$

$$q = 100 \times 2 = 200pC = 2 \times 10^{-10}C$$

for capacitance,  $c = 3pF$

$$q = 100 \times 3 = 300pC = 3 \times 10^{-10}C$$

for capacitance,  $c = 4pF$

$$q = 100 \times 4 = 400pC = 4 \times 10^{-10} C$$

**Q 2.8) In a parallel plate capacitor with air between the plates, each plate has an area of  $6 \times 10^{-3} m^2$  and the distance between the plates is 3 mm. Calculate the capacitance of the capacitor. If this capacitor is connected to a 100 V supply, what is the charge on each plate of the capacitor?**

**Solution:**

Given,

The area of plate of the capacitor,  $A = 6 \times 10^{-3} m^2$

Distances between the plates,  $d = 3mm = 3 \times 10^{-3} m$

Voltage supplied,  $V = 100V$

Capacitance of a parallel plate capacitor is given by,  $C = \frac{\epsilon \times A}{d}$

Here,

$\epsilon_0$  = permittivity of free space =  $8.854 \times 10^{-12} N^{-1} m^{-2} C^{-2}$

$$C = \frac{8.854 \times 10^{-12} \times 6 \times 10^{-3}}{3 \times 10^{-3}} = 17.71 \times 10^{-12} F = 17.71 pF.$$

Therefore, each plate of the capacitor is having a charge of

$$q = VC = 100 \times 17.71 \times 10^{-12} C = 1.771 \times 10^{-9} C$$

**Q 2.9:** Explain what would happen if, in the capacitor given in Exercise 2.8, a 3 mm thick mica sheet (of dielectric constant = 6) were inserted between the plates,

(a) while the voltage supply remained connected.

(b) after the supply was disconnected.

**Solution:**

(a) Dielectric constant of the mica sheet,  $k = 6$

If voltage supply remained connected, the voltage between two plates will be constant.

Supply voltage,  $V = 100 \text{ V}$

Initial capacitance,  $C = 1.771 \times 10^{-11} \text{ F}$

New capacitance,  $C_1 = kC = 6 \times 1.771 \times 10^{-11} \text{ F} = 106 \text{ pF}$

New charge,  $q_1 = C_1V = 106 \times 100 \text{ pC} = 1.06 \times 10^{-8} \text{ C}$

Potential across the plates remain 100 V.

(b) Dielectric constant,  $k = 6$

Initial capacitance,  $C = 1.771 \times 10^{-11} \text{ F}$

New capacitance,  $C_1 = kC = 6 \times 1.771 \times 10^{-11} \text{ F} = 106 \text{ pF}$

If the supply voltage is removed, then there will be a constant amount of charge in the plates.

Charge =  $1.771 \times 10^{-9} \text{ C}$

Potential across the plates is given by,

$$V_1 = q/C_1 = \frac{1.771 \times 10^{-9}}{106 \times 10^{-12}}$$

$$= 16.7 \text{ V}$$

**Q 2.10)** A 12pF capacitor is connected to a 50V battery. How much electrostatic energy is stored in the capacitor?

**Solution:**

Given,

Capacitance of the capacitor,  $C = 12 \text{ pF} = 12 \times 10^{-12} \text{ F}$

Potential difference,  $V = 50 \text{ V}$

Electrostatic energy stored in the capacitor is given by the relation,

$$E = \frac{1}{2} CV^2 = \frac{1}{2} \times 12 \times 10^{-12} \times (50)^2 \text{ J} = 1.5 \times 10^{-8} \text{ J}$$

Therefore, the electrostatic energy stored in the capacitor is  $1.5 \times 10^{-8} \text{ J}$ .

**Q 2.11)** A 600pF capacitor is charged by a 200V supply. It is then disconnected from the supply and is connected to another uncharged 600 pF capacitor. How much electrostatic energy is lost in the process?

**Solution:**

Given,

Capacitance,  $C = 600\text{pF}$

Potential difference,  $V = 200\text{v}$

Electrostatic energy stored in the capacitor is given by:

$$E_1 = \frac{1}{2} CV^2 = \frac{1}{2} \times (600 \times 10^{-12}) \times (200)^2 \text{J} = 1.2 \times 10^{-5} \text{ J}$$

According to the question, the source is disconnected to the 600pF and connected to another capacitor of 600pF, then equivalent capacitance ( $C_{eq}$ ) of the combination is given by,

$$\frac{1}{C_{eq}} = \frac{1}{C} + \frac{1}{C}$$

$$\frac{1}{C_{eq}} = \frac{1}{600} + \frac{1}{600}$$

$$= \frac{2}{600} = \frac{1}{300}$$

$$C_{eq} = 300\text{pF}$$

New electrostatic energy can be calculated by:

$$E_2 = \frac{1}{2} CV^2 = \frac{1}{2} \times 300 \times 10^{-12} \times (200)^2 \text{ J} = 0.6 \times 10^{-5} \text{ J}$$

Loss in electrostatic energy,

$$E = E_1 - E_2$$

$$E = 1.2 \times 10^{-5} - 0.6 \times 10^{-5} \text{ J} = 0.6 \times 10^{-5} \text{ J} = 6 \times 10^{-6} \text{ J}$$

Therefore, the electrostatic energy lost in the process is  $6 \times 10^{-6} \text{ J}$ .

**Q2.12)** A charge of 8 mC is located at the origin. Calculate the work done in taking a small charge of  $-2 \times 10^{-9} \text{ C}$  from a point P (0, 0, 3 cm) to a point Q (0, 4 cm, 0), via a point R (0, 6 cm, 9 cm).



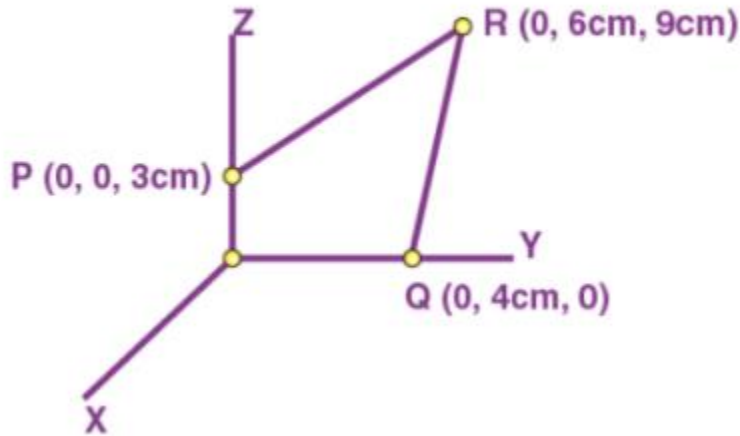

**Solution:**

Charge located at the origin,  $q = 8 \text{ mC} = 8 \times 10^{-3} \text{ C}$

The magnitude of the charge taken from the point P to R and then to Q,  $q_1 = -2 \times 10^{-9} \text{ C}$

Here  $OP = d_1 = 3 \text{ cm} = 3 \times 10^{-2} \text{ m}$

$OQ = d_2 = 4 \text{ cm} = 4 \times 10^{-2} \text{ m}$

$$\text{Potential at the point P, } V_1 = \frac{q}{4\pi\epsilon_0 d_1}$$

$$\text{Potential at the point Q, } V_2 = \frac{q}{4\pi\epsilon_0 d_2}$$

The work done (W) is independent of the path

Therefore,  $W = q_1[V_1 - V_2]$

$$W = q_1 \left[ \frac{q}{4\pi\epsilon_0 d_2} - \frac{q}{4\pi\epsilon_0 d_1} \right]$$

$$W = \frac{qq_1}{4\pi\epsilon_0} \left[ \frac{1}{d_2} - \frac{1}{d_1} \right]$$

Where,  $\frac{1}{4\pi\epsilon_0} = 9 \times 10^9 \text{ Nm}^2 \text{ C}^{-2}$

Therefore,

$$W = 9 \times 10^9 \times 8 \times 10^{-3} \times (-2 \times 10^{-9}) \left[ \frac{1}{4 \times 10^{-2}} - \frac{1}{3 \times 10^{-2}} \right]$$

$$= -144 \times 10^{-3} \times (-100/12)$$

= 1.2 Joule

Therefore, the work done during the process is 1.2 J

**Q2.13) A cube of side  $b$  has a charge  $q$  at each of its vertices. Determine the potential and electric field due to this charge array at the centre of the cube.**

**Solution:**

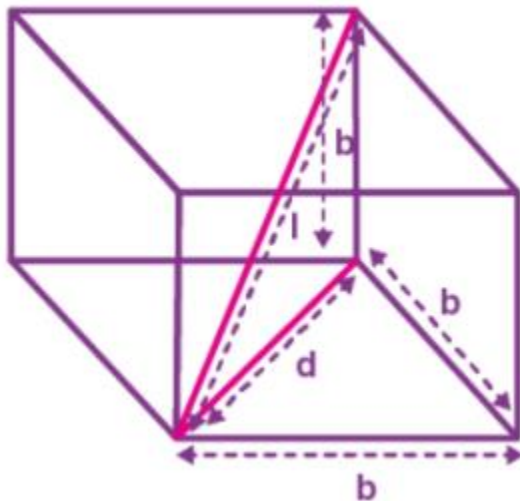

Sides of the cube =  $b$

Charge at the vertices =  $q$

Diagonal of one of the sides of the cube

$$d^2 = \sqrt{b^2 + b^2} = \sqrt{2b^2}$$

$$d = b\sqrt{2}$$

Length of the diagonal of the cube

$$l^2 = \sqrt{d^2 + b^2} = \sqrt{2b^2 + b^2} = \sqrt{3b^2}$$

$$l = b\sqrt{3}$$

The distance between one of the vertices and the centre of the cube is

$$r = l/2 = (b\sqrt{3}/2)$$

The electric potential ( $V$ ) at the centre of the cube is due to the eight charges at the vertices

$$V = 8q/4\pi\epsilon_0$$

$$V = \frac{8q}{4\pi\epsilon_0 \left(b \frac{\sqrt{3}}{2}\right)} = \frac{4q}{\sqrt{3}\pi\epsilon_0 b}$$

Therefore, potential at the centre of the cube is  $\frac{4q}{\sqrt{3}\pi\epsilon_0 b}$

The electric field intensity at the centre of the cube, due to the eight charges is zero. The charges are distributed symmetrically with respect to the centre of the cube. Therefore, they get cancelled.

**Q2.14) Two tiny spheres carrying charges  $1.5 \mu\text{C}$  and  $2.5 \mu\text{C}$  are located 30 cm apart. Find the potential and electric field:**

**(a) at the mid-point of the line joining the two charges, and**

**(b) at a point 10 cm from this midpoint in a plane normal to the line and passing through the midpoint.**

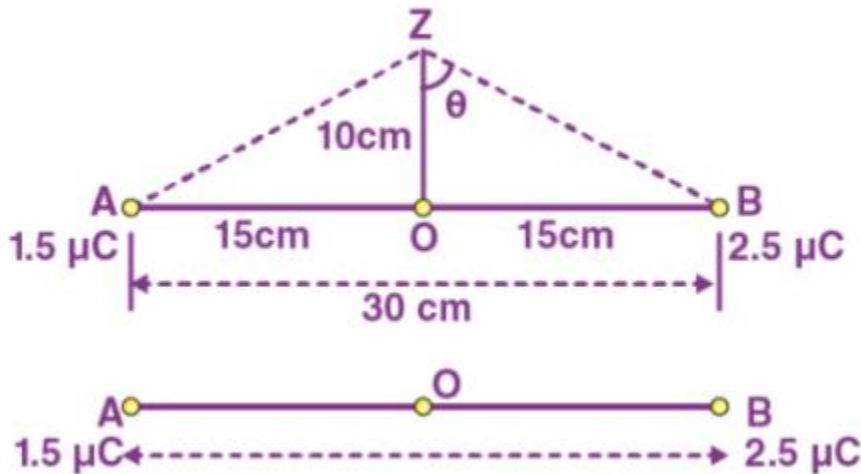

**Solution:**

Two tiny spheres carrying charges are located at points A and B

The charge at point A,  $q_1 = 1.5 \mu\text{C}$

The charge at point B,  $q_2 = 2.5 \mu\text{C}$

The distance between the two charges = 30 cm = 0.3 m

(a) Let O be the midpoint. Let  $V_1$  and  $E_1$  be the potential and electric field respectively at the midpoint.

$V_1 =$  Potential due to charge at A + Potential due to charge at B

$$V_1 = \frac{q_1}{4\pi\epsilon_0 \left(\frac{d}{2}\right)} + \frac{q_2}{4\pi\epsilon_0 \left(\frac{d}{2}\right)} \quad V_1 = \frac{1}{4\pi\epsilon_0 \left(\frac{d}{2}\right)} (q_1 + q_2)$$

Here,

$\epsilon_0 =$  Permittivity of the free space

$$\frac{1}{4\pi\epsilon_0} = 9 \times 10^9 \text{ NC}^2\text{m}^{-2}$$

Therefore,

$$V_1 = \frac{9 \times 10^9 \times 10^{-6}}{\left(\frac{0.30}{2}\right)} (2.5 + 1.5) = 2.4 \times 10^5 \text{ V}$$

Electric field at O,  $E_1$  = Electric field due to  $q_2$  – Electric field due to  $q_1$

$$= \frac{q_2}{4\pi\epsilon_0\left(\frac{d}{2}\right)^2} - \frac{q_1}{4\pi\epsilon_0\left(\frac{d}{2}\right)^2} = \frac{9 \times 10^9}{\left(\frac{0.30}{2}\right)^2} \times 10^{-6} \times (2.5 - 1.5)$$

$$= 400 \times 10^3 \text{ V/m}$$

Therefore, the potential at midpoint is  $2.4 \times 10^5 \text{ V}$  and the electric field at the midpoint is  $400 \times 10^3 \text{ V/m}$ .

(b) Consider a point Z such that the distance  $OZ = 10 \text{ cm} = 0.1 \text{ m}$  as shown in the figure.

Let  $V_2$  and  $E_2$  be the potential and electric field respectively at point Z. The distance

$$BZ = AZ = \sqrt{(0.1)^2 + (0.15)^2} = 0.18 \text{ m}$$

The potential at  $V_2$  = Potential due to the charge at A + Potential due to the charge at B

$$= \frac{q_1}{4\pi\epsilon_0(AZ)} + \frac{q_2}{4\pi\epsilon_0(BZ)}$$

$$= \frac{9 \times 10^9 \times 10^{-6}}{0.18} (1.5 + 2.5)$$

$$= 2 \times 10^5 \text{ V}$$

The electric field due to  $q_1$  at Z

$$E_A = \frac{q_1}{4\pi\epsilon_0(AZ)^2} = \frac{9 \times 10^9 \times 1.5 \times 10^{-6}}{(0.18)^2}$$

$$= 416 \times 10^3 \text{ V/m}$$

The electric field due to  $q_2$  at Z

$$E_B = \frac{q_2}{4\pi\epsilon_0(BZ)^2} = \frac{9 \times 10^9 \times 2.5 \times 10^{-6}}{(0.18)^2}$$

$$= 694 \times 10^3 \text{ V/m}$$

The resultant field intensity at Z

$$E = \sqrt{E_A^2 + E_B^2 + 2E_A E_B \cos 2\theta}$$

From the figure we get  $\cos \theta = (0.10/0.18) = 5/9 = 0.5556$

$$\theta = \cos^{-1}(0.5556) = 56.25$$

$$2\theta = 2 \times 56.25 = 112.5^\circ$$

$$\cos 2\theta = -0.38$$

$$E = \sqrt{(0.416 \times 10^6)^2 + (0.69 \times 10^6)^2 + 2 \times 0.416 \times 0.69 \times 10^{12} \times (-0.38)}$$

$$= 6.6 \times 10^5 \text{ V/m}$$

Therefore the potential at the point Z is  $694 \times 10^3 \text{ V/m}$  and the electric field is  $6.6 \times 10^5 \text{ V/m}$ .

**Q2.15) A spherical conducting shell of inner radius  $r_1$  and outer radius  $r_2$  has a charge  $Q$ .**

**(a) A charge  $q$  is placed at the centre of the shell. What is the surface charge density on the inner and outer surfaces of the shell?**

**(b) Is the electric field inside a cavity (with no charge) zero, even if the shell is not spherical, but has any irregular shape? Explain.**

**Solution:**

(a) If a charge  $+q$  is placed at the centre of the shell, a charge of magnitude  $-q$  is induced in the inner surface of the shell. Therefore, the surface charge density at the inner surface of the shell is given by the relation,

$$\sigma_1 = \text{Total charge} / \text{Inner surface area} = -q/4\pi r_1^2 \text{---(1)}$$

A charge  $+q$  is induced on the outer surface of the shell. The total charge on the outer surface of the shell is  $Q+q$ . Surface charge density at the outer surface of the shell

$$\sigma_2 = \text{Total charge} / \text{Outer surface area} = (Q+q)/4\pi r_1^2 \text{---(2)}$$

(b) Yes. The electric field inside a cavity (with no charge) will be zero, even if the shell is not spherical but has any irregular shape. Take a closed-loop, part of which is inside the cavity along a field line and the rest inside the conductor. Since the field inside the conductor is zero, this gives a net work done by the field in carrying a test charge over a closed loop. We know this is impossible for an electrostatic field. Hence, there are no field lines inside the cavity (i.e., no field), and no charge on the inner surface of the conductor, whatever be its shape.

**Q2.16) (a) Show that the normal component of electrostatic field has a discontinuity from one side of a charged surface to another given by**

$$(E_2 - E_1) \cdot \hat{n} = \frac{\sigma}{\epsilon_0}$$

where  $\hat{n}$  is a unit vector normal to the surface at a point and  $\sigma$  is the surface charge density at that

point. (The direction of  $\hat{n}$  is from side 1 to side 2.) Hence, show that just outside a conductor, the

electric field is  $\sigma \hat{n} / \epsilon_0$ .

**(b) Show that the tangential component of the electrostatic field is continuous from one side of a charged surface to another. [Hint: For (a), use Gauss's law. For, (b) use the fact that work done by electrostatic field on a closed loop is zero].**

**Solution:**

(a) Let  $E_1$  be the electric field at one side of the charged body and  $E_2$  is the electric field at the other side of the charged body. If the infinite plane charged body has a uniform thickness, the electric field due to one of the surface of the charged body is

$$\vec{E}_1 = -\frac{\sigma}{2\epsilon_0} \hat{n} \quad \text{---(1)}$$

here,

$\hat{n}$  = unit vector normal to the surface at a point

$\sigma$  = surface charge density at that point

The electric field due to the other surface of the charged body is

$$\vec{E}_2 = \frac{\sigma}{2\epsilon_0} \hat{n} \quad \text{---(2)}$$

The electric field at any point due to the charge surfaces

$$\vec{E}_2 - \vec{E}_1 = \frac{\sigma}{2\epsilon_0} \hat{n} + \frac{\sigma}{2\epsilon_0} \hat{n} = \frac{\sigma}{\epsilon_0} \hat{n}$$

Since inside the conductor,  $\vec{E}_1 = 0$

$$\vec{E}_2 - \vec{E}_1 = \frac{\sigma}{\epsilon_0} \hat{n} \quad \text{---(3)}$$

Therefore, the electric field just outside the conductor is  $\frac{\sigma}{\epsilon_0} \hat{n}$

(b) When a charged particle is moved from one point to the other on a closed-loop, the work done by the electrostatic field is zero. Hence, the tangential component of the electrostatic field is continuous from one side of a charged surface to the other.

**Q2.17) A long charged cylinder of linear charged density  $\lambda$  is surrounded by a hollow co-axial conducting cylinder. What is the electric field in the space between the two cylinders?**

**Solution:**

Let the length of the charged cylinder and the hollow co-axial conducting cylinder be  $L$

Charge density of the long charged cylinder is  $\lambda$

Let  $E$  be the electric field in the space between the two cylinders

According to Gauss theorem, the electric flux through the Gaussian surface is given as  $\Phi = E (2\pi d)L$

Here,

$d$  is the distance between the common axis of the cylinders

Therefore,  $\Phi = E (2\pi d)L = q/\epsilon_0$

here,  $q$  is the charge on the inner surface of the outer cylinder

$\epsilon_0$  is the permittivity of the free space

$E (2\pi d)L = \lambda L/\epsilon_0$

$E = \lambda/2\pi d\epsilon_0$

Therefore, the electric field in the space between the two cylinders is  $\lambda/2\pi d\epsilon_0$

**Q2.18) In a hydrogen atom, the electron and proton are bound at a distance of about  $0.53 \text{ \AA}$ :**  
**(a) Estimate the potential energy of the system in eV, taking the zero of the potential energy at infinite separation of the electron from proton.**  
**(b) What is the minimum work required to free the electron, given that its kinetic energy in the orbit is half the magnitude of potential energy obtained in (a)?**  
**(c) What are the answers to (a) and (b) above if the zero of potential energy is taken at  $1.06 \text{ \AA}$  separation?**

**Solution:**

The distance between the proton and electron of hydrogen atom,  $d = 0.53 \text{ \AA}$

Charge of the electron,  $q_1 = -1.6 \times 10^{-19} \text{ C}$

Charge of the proton,  $q_2 = +1.6 \times 10^{-19} \text{ C}$

(a) At infinite separation of electron and proton, potential energy is zero

Potential energy of the system = Potential energy at infinity – Potential energy at distance  $d$

$$= 0 - \frac{q_1 q_2}{4\pi\epsilon_0 d}$$

here,

$\epsilon_0$  is the permittivity of the free space

$$\frac{1}{4\pi\epsilon_0} = 9 \times 10^9 \text{ Nm}^2\text{C}^{-2}$$

$$\text{Potential energy} = 0 - \frac{9 \times 10^9 \times (1.6 \times 10^{-19})^2}{0.53 \times 10^{10}} = -43.7 \times 10^{-19} \text{ J}$$

Potential energy =  $-43.7 \times 10^{-19} / 1.6 \times 10^{-19} = -27.2 \text{ eV}$  [Since  $1.6 \times 10^{-19} \text{ J} = 1 \text{ eV}$ ]

Therefore, the potential energy of the system is  $-27.2 \text{ eV}$

(b) Half of the magnitude of the potential energy is equal to the kinetic energy

Kinetic energy =  $|V|/2 = (1/2) \times (27.2) = 13.6 \text{ eV}$

Total energy = Kinetic energy + potential energy

=  $13.6 \text{ eV} - 27.2 \text{ eV}$

Total energy =  $-13.6 \text{ eV}$

Therefore, the minimum work required to free an electron is  $-13.6 \text{ eV}$

(c) When the zero of the potential energy is taken as,  $d_1 = 1.06 \text{ \AA}$

Potential energy of the system = Potential energy at  $d_1$  – Potential energy at  $d$

$$= \frac{q_1 q_2}{4\pi\epsilon_0 d_1} - 27.2 \text{ eV}$$

$$= \frac{9 \times 10^9 \times (1.6 \times 10^{-19})^2}{1.06 \times 10^{10}} - 27.2 \text{ eV}$$

=  $21.73 \times 10^{-19} \text{ J} - 27.2 \text{ eV}$

=  $13.58 \text{ eV} - 27.2 \text{ eV}$  [Since  $1.6 \times 10^{-19} \text{ J} = 1 \text{ eV}$ ]

=  $-13.6 \text{ eV}$

**Q2.19) If one of the two electrons of the  $\text{H}_2$  molecule is removed, we get a hydrogen molecular ion  $\text{H}_2^+$ . In the ground state of the ion, the two protons are separated by roughly  $1.5 \text{ \AA}$ , and the electron is roughly  $1 \text{ \AA}$  from each proton. Determine the potential energy of the system. Specify your choice of the zero of potential energy.**

**Solution:**

Charge of the 1<sup>st</sup> proton,  $q_1 = 1.6 \times 10^{-19} \text{ C}$

Charge of the 2<sup>nd</sup> proton,  $q_2 = 1.6 \times 10^{-19} \text{ C}$



Charge of the electron,  $q_3 = -1.6 \times 10^{-19} \text{ C}$

Distance between the 1<sup>st</sup> and the 2<sup>nd</sup> proton,  $d_1 = 1.5 \times 10^{-10} \text{ m}$

Distance between the 1<sup>st</sup> proton and the electron,  $d_2 = 1 \times 10^{-10} \text{ m}$

Distance between the 2<sup>nd</sup> proton and the electron,  $d_3 = 1 \times 10^{-10} \text{ m}$

The potential energy at infinity is zero

Therefore, the potential energy of the system is

$$V = \frac{q_1 q_2}{4\pi\epsilon_0 d_1} + \frac{q_2 q_3}{4\pi\epsilon_0 d_3} + \frac{q_3 q_1}{4\pi\epsilon_0 d_2}$$

$$V = \frac{1}{4\pi\epsilon_0} \left[ \frac{q_1 q_2}{d_1} + \frac{q_2 q_3}{d_3} + \frac{q_3 q_1}{d_2} \right]$$

Substituting  $(1/4\pi\epsilon_0) = 9 \times 10^9 \text{ Nm}^2\text{C}^{-2}$  we get

$$V = 9 \times 10^9 \left[ \frac{1.6 \times 10^{-19} \times 1.6 \times 10^{-19}}{1.5 \times 10^{-10}} + \frac{1.6 \times 10^{-19} \times (-1.6 \times 10^{-19})}{1 \times 10^{-10}} + \frac{(-1.6 \times 10^{-19})(1.6 \times 10^{-19})}{1 \times 10^{-10}} \right]$$

$$V = \frac{9 \times 10^9 \times 10^{-19} \times 10^{-19}}{10^{-10}} \left[ \frac{(1.6)^2}{1.5} - (1.6)^2 - (1.6)^2 \right]$$

$$= -30.7 \times 10^{-19} \text{ J}$$

$$= -19.2 \text{ eV} \quad (1 \text{ eV} = 1.6 \times 10^{-19} \text{ J})$$

Therefore, the potential energy of the system is -19.2 eV.

**Q2.20) Two charged conducting spheres of radii  $a$  and  $b$  are connected to each other by a wire. What is the ratio of electric fields at the surfaces of the two spheres? Use the result obtained to explain why the charge density on the sharp and pointed ends of a conductor is higher than on its flatter portions.**

**Solution:**

Let A be the sphere of radius  $a$ , Charge  $Q_A$  and capacitance  $C_A$

Let B be the sphere of radius  $b$ , Charge  $Q_B$  and capacitance  $C_B$

The conducting spheres are connected by a wire, therefore the potential of both the capacitors will be  $V$

$$\text{The electric field due to a, } E_A = \frac{Q_A}{4\pi\epsilon_0 a^2}$$

$$\text{The electric field due to b, } E_B = \frac{Q_B}{4\pi\epsilon_0 b^2}$$

The ratio of electric fields at the surface of the spheres is

$$\frac{E_A}{E_B} = \frac{Q_A}{4\pi\epsilon_0 a^2} \times \frac{b^2 4\pi\epsilon_0}{Q_B}$$

$$\frac{E_A}{E_B} = \frac{Q_A}{Q_B} \times \frac{b^2}{a^2} \text{ ---(1)}$$

$$\frac{Q_A}{Q_B} = \frac{C_A V}{C_B V}$$

$$\frac{Q_A}{Q_B} = \frac{a}{b} \text{ ---(2)}$$

Putting equation (2) in equation (1) we get

$$\frac{E_A}{E_B} = \frac{a}{b} \times \frac{b^2}{a^2}$$

Therefore, the ratio of the electric field at the surface is b/a

A sharp and pointed end is like a sphere of very small radius and the flat portion is like a sphere of large radius. Therefore, the charge density is of pointed ends is higher than the flat portion.

**Q2.21) Two charges  $-q$  and  $+q$  are located at points  $(0, 0, -a)$  and  $(0, 0, a)$ , respectively.**

**(a) What is the electrostatic potential at the points  $(0, 0, z)$  and  $(x, y, 0)$ ?**

**(b) Obtain the dependence of potential on the distance  $r$  of a point from the origin when  $r/a \gg 1$ .**

**(c) How much work is done in moving a small test charge from the point  $(5,0,0)$  to  $(-7,0,0)$  along the  $x$ -axis? Does the answer change if the path of the test charge between the same points is not along the  $x$ -axis?**

**Solution:**

(a) Two charges  $-q$  and  $+q$  are located at points  $(0, 0, -a)$  and  $(0, 0, a)$ , respectively. They will form a dipole. The point  $(0, 0, z)$  is on the axis of the dipole and  $(x,y,0)$  is normal to the dipole. The electrostatic potential at  $(x,y,0)$  is zero. The electrostatic potential at  $(0,0, z)$  is given by

$$V = \frac{1}{4\pi\epsilon_0} \left( \frac{q}{z-a} \right) + \frac{1}{4\pi\epsilon_0} \left( -\frac{q}{z+a} \right)$$

$$V = \frac{q(z+a-z+a)}{4\pi\epsilon_0(z^2-a^2)}$$

$$V = \frac{q(2a)}{4\pi\epsilon_0(z^2-a^2)} = \frac{p}{4\pi\epsilon_0(z^2-a^2)}$$

$\epsilon_0$  = Permittivity of free space

$p =$  dipole moment of the system  $= q \times 2a$

(b) The distance "r" is much larger than half of the distance between the two charges. Therefore, the potential at the point r is inversely proportional to the square of the distance. i.e.,  $V \propto (1/r^2)$ .

(c) x,y plane is a equipotential surface and x-axis is a equipotential line. Therefore, the change in potential (dV) along x-axis will be zero. The work done in moving a small test charge from the point (5,0,0) to (-7,0,0) along the x-axis is given by

Potential at (5,0,0)

$$V_1 = \frac{1}{4\pi\epsilon_0} \left( \frac{q}{\sqrt{(5-0)^2 - a^2}} \right) + \frac{1}{4\pi\epsilon_0} \left( -\frac{q}{\sqrt{(5-0)^2 - (-a)^2}} \right) = 0$$

Potential at (-7,0,0)

$$V_2 = \frac{1}{4\pi\epsilon_0} \left( \frac{q}{\sqrt{((-7)-0)^2 - a^2}} \right) + \frac{1}{4\pi\epsilon_0} \left( -\frac{q}{\sqrt{((-7)-0)^2 - (-a)^2}} \right) = 0$$

$$V_2 - V_1 = 0$$

Work done = Charge (q) x Change in Potential ( $V_2 - V_1$ )

Since the change in potential is zero, the work done is also zero.

The change in potential is independent of the path taken between the two points. Therefore, the work done in moving a point charge will remain zero.

**Q2. 22) Figure below shows a charge array known as an electric quadrupole. For a point on the axis of the quadrupole, obtain the dependence of potential on r for  $r/a \gg 1$ , and contrast your results with that due to an electric dipole, and an electric monopole (i.e., a single charge).**



**Solution:**

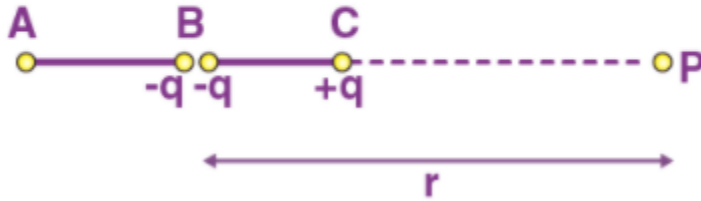

Four charges are placed at points A, B, B and C respectively.

Let us consider a point P located at the axis of the quadrupole.

It can be considered that the electric quadrupole has three charges.

The charge  $+q$  is placed at A

The charge  $-2q$  is placed at B

The charge  $+q$  is placed at C

$AB = BC = a$

$BP = r$

$PA = r + a$

$PZ = r - a$

Therefore, the electrostatic potential due to the system of three charges is

$$\begin{aligned}
 V &= \frac{1}{4\pi\epsilon_0} \left[ \frac{q}{PA} - \frac{2q}{PB} + \frac{q}{PC} \right] \\
 &= \frac{1}{4\pi\epsilon_0} \left[ \frac{q}{r+a} - \frac{2q}{r} + \frac{q}{r-a} \right] \\
 &= \frac{q}{4\pi\epsilon_0} \left[ \frac{r(r-a) - 2(r+a)(r-a) + r(r+a)}{r(r+a)(r-a)} \right] \\
 &= \frac{q}{4\pi\epsilon_0} \left[ \frac{r^2 - ra - 2r^2 + 2a^2 + r^2 + ra}{r(r^2 - a^2)} \right] = \frac{q}{4\pi\epsilon_0} \left[ \frac{2a^2}{r(r^2 - a^2)} \right] \\
 &= \frac{2qa^2}{4\pi\epsilon_0 r^3 \left( 1 - \frac{a^2}{r^2} \right)}
 \end{aligned}$$

Since  $r/a \gg 1$ ,

$a/r \ll 1$

Therefore,  $a^2/r^2$  is negligible

So we get,

$$V = \frac{2qa^2}{4\pi\epsilon_0 r^3}$$

Therefore we get,

$V \propto 1/r^3$

However, for a dipole,  $V \propto 1/r^2$

And for a monopole,  $V \propto 1/r$

**Q2.23) An electrical technician requires a capacitance of  $2 \mu\text{F}$  in a circuit across a potential difference of  $1 \text{ kV}$ . A large number of  $1 \mu\text{F}$  capacitor are available to him each of which can withstand a potential difference of not more than  $400 \text{ V}$ . Suggest a possible arrangement that requires the minimum number of capacitors.**

**Solution:**

Required Capacitance,  $C = 2 \mu\text{F}$

Potential difference,  $V = 1 \text{ kV} = 1000 \text{ V}$

Capacitance of each capacitor,  $C_1 = 1 \mu\text{F}$

Potential difference that the capacitors can withstand,  $V_1 = 400 \text{ V}$

Suppose a number of capacitors are connected in series and then connected parallel to each other. Then the number of capacitors in each row is given by

$$1000/400 = 2.5$$

Therefore, the number of capacitors connected in series is three.

So the capacitance of each row is  $\frac{1}{1+1+1} = \frac{1}{3} \mu\text{F}$

Let there be  $n$  parallel rows. Each of these rows will have 3 capacitors. Therefore, the equivalent capacitance of the circuit is given as

$$\frac{1}{3} + \frac{1}{3} + \frac{1}{3} + \dots - n \text{ terms}$$

The required capacitance of the circuit is  $2 \mu\text{F}$

Therefore,  $n/3 = 2$

$$n = 6$$

Therefore, there are 6 rows of three capacitors in the circuit. A minimum of  $6 \times 3 = 18$  capacitors are required.

**Q2.24) What is the area of the plates of a  $2 \text{ F}$  parallel plate capacitor, given that the separation between the plates is  $0.5 \text{ cm}$ ? [You will realise from your answer why ordinary capacitors are in the range of  $\mu\text{F}$  or less. However, electrolytic capacitors do have a much larger capacitance ( $0.1 \text{ F}$ ) because of the very minute separation between the conductors.]**

**Solution:**

Capacitance of the parallel plate capacitor,  $C = \epsilon_0 A/d$

Capacitance of the capacitor,  $C = 2 \text{ F}$

Separation between the plates,  $d = 0.5 \text{ cm} = 0.5 \times 10^{-2} \text{ m}$

$\epsilon_0$  = permittivity of the free space =  $8.85 \times 10^{-12} \text{ C}^2\text{N}^{-1}\text{m}^{-2}$

Area of the plates,  $A = Cd/\epsilon_0$

$$A = [2 \times 0.5 \times 10^{-2}] / 8.85 \times 10^{-12}$$

$$= 1130 \times 10^6 \text{ m}^2$$

**Q2.25) Obtain the equivalent capacitance of the network in Figure. For a 300 V supply, determine the charge and voltage across each capacitor.**

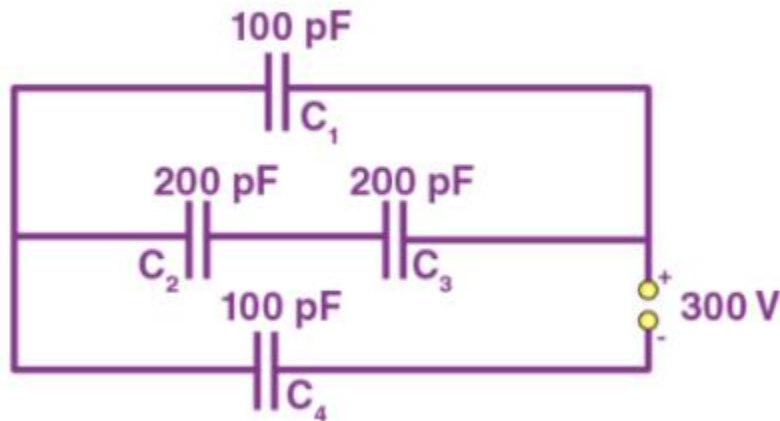

**Solution:**

The above figure can be redrawn as below

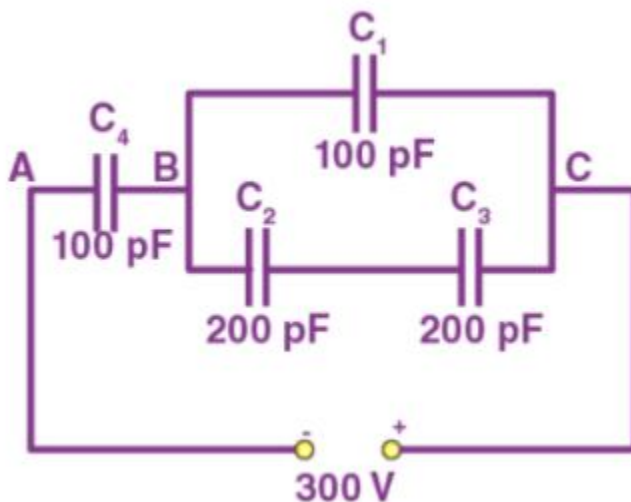

The capacitors  $C_2$  and  $C_3$  are connected in series. The equivalent capacitance  $C'$

$$\frac{1}{C'} = \frac{1}{C_2} + \frac{1}{C_3} = \frac{1}{200} + \frac{1}{200} = \frac{2}{200}$$

$$C' = 100 \text{ pF}$$

The capacitors  $C'$  and  $C_1$  are parallel. The equivalent capacitance is  $C'' = C' + C_1$

$$C'' = 100 + 100 = 200 \text{ pF}$$

$C''$  and  $C_4$  are connected in series. Let the equivalent capacitance be  $C$

$$\frac{1}{C} = \frac{1}{C''} + \frac{1}{C_4} = \frac{1}{200} + \frac{1}{100} = \frac{3}{200}$$

$$C = 200/3 \text{ pF}$$

Hence the equivalent capacitance of the circuit is  $200/3 \text{ pF}$

$$\text{Total charge, } Q = CV = \frac{200}{3} \times 10^{-12} \times 300 = 2 \times 10^{-8} \text{ C}$$

$$Q = Q_4 = 2 \times 10^{-8} \text{ C}$$

Potential difference across  $C_4$ ,  $V_4 = Q/C_4$

$$= (2 \times 10^{-8}) / (100 \times 10^{-12}) = 200 \text{ V}$$

Potential difference across  $C''$ ,  $V'' = 300 \text{ V} - 200 \text{ V} = 100 \text{ V}$

Potential difference across  $C_1$ ,  $V_1 = V'' = 100 \text{ V}$

Charge across  $C_1$ ,  $Q_1 = C_1 V_1 = (100 \times 10^{-12}) \times 100 = 10^{-8} \text{ C}$

The charge across  $C_2$  and  $C_3$ ,  $Q_2 = Q - Q_1 = 2 \times 10^{-8} - 10^{-8} = 10^{-8} \text{ C}$

Potential across  $C_2$ ,  $V_2 = Q_2/C_2 = 10^{-8} / (200 \times 10^{-12}) = 50 \text{ V}$

Potential across  $C_3$ ,  $V_3 = Q_2/C_3 = 10^{-8} / (200 \times 10^{-12}) = 50 \text{ V}$

Therefore,

$$Q_1 = 10^{-8} \text{ C}, V_1 = 100 \text{ V}$$

$$Q_2 = 10^{-8} \text{ C}, V_2 = 50 \text{ V}$$

$$Q_2 = Q_3 = 10^{-8} \text{ C}, V_3 = 50 \text{ V}$$

$$Q_4 = 2 \times 10^{-8} \text{ C}, V_4 = 200 \text{ V}$$

**Q2.26)** The plates of a parallel plate capacitor have an area of  $90 \text{ cm}^2$  each and are separated by  $2.5 \text{ mm}$ . The capacitor is charged by connecting it to a  $400 \text{ V}$  supply.

(a) How much electrostatic energy is stored by the capacitor?

(b) View this energy as stored in the electrostatic field between the plates, and obtain the energy per unit volume  $u$ . Hence arrive at a relation between  $u$  and the magnitude of electric field  $E$  between the plates.

**Solution:**

Area of the plates of a parallel plate capacitor,  $A = 90 \text{ cm}^2 = 90 \times 10^{-4} \text{ m}^2$

Separation between the plates,  $d = 2.5 \text{ mm} = 2.5 \times 10^{-3} \text{ m}$

Potential difference across the plates,  $V = 400 \text{ V}$

Capacitance of the capacitor,  $C = \epsilon_0 A/d$

Electrostatic energy stored in the capacitor,  $E = (1/2) CV^2$

$$= \frac{1}{2} \frac{\epsilon_0 A}{d} V^2 = \frac{1}{2} \frac{8.85 \times 10^{-12} \times 90 \times 10^{-4} \times 400^2}{2 \times 2.5 \times 10^{-3}} = 2.55 \times 10^{-6} \text{ J}$$

Therefore, the electrostatic energy stored by the capacitor is  $2.55 \times 10^{-6} \text{ J}$

Volume of the capacitor,  $V = A \times d$

$$= 90 \times 10^{-4} \times 25 \times 10^{-3}$$

$$= 2.25 \times 10^{-4} \text{ m}^3$$

Energy stored in the capacitor per unit volume is

$$u = EV = \frac{\frac{1}{2} CV^2}{Ad} = \frac{\frac{\epsilon_0 A}{2d} V^2}{Ad} = \frac{1}{2} \epsilon_0 \left(\frac{V}{d}\right)^2$$

Here,  $V/d =$  Electric intensity  $= E$

$$\text{Therefore, } u = \frac{1}{2} \epsilon_0 E^2$$

**Q2.27) A  $4 \mu\text{F}$  capacitor is charged by a  $200 \text{ V}$  supply. It is then disconnected from the supply and is connected to another uncharged  $2 \mu\text{F}$  capacitors. How much electrostatic energy of the first capacitor is lost in the form of heat and electromagnetic radiation?**

**Solution:**

Capacitance of the capacitor,  $C_1 = 4 \mu\text{F}$

Supply voltage,  $V_1 = 200 \text{ V}$

Capacitance of the uncharged capacitor,  $C_2 = 2 \mu\text{F}$

Electrostatic energy stored in  $C_1$  is given as

$$\begin{aligned} E_1 &= (1/2)C_1V_1^2 \\ &= (1/2) \times 4 \times 10^{-6} \times (200)^2 \\ &= 8 \times 10^{-2} \text{ J} \end{aligned}$$

When  $C_1$  is disconnected from the power supply and connected to  $C_2$ , the voltage acquired by it is  $V_2$ .

According to the law of conservation of energy, the initial charge on the capacitor  $C_1$  is equal to the final charge on the capacitors  $C_1$  and  $C_2$ .

$$V_2 (C_1 + C_2) = C_1V_1$$

$$V_2 (4 + 2) \times 10^{-6} = 4 \times 10^{-6} \times 200$$



$$V_2 = (400/3) \text{ V}$$

Electrostatic energy of the combination is

$$\begin{aligned} E_2 &= (1/2)(C_1+C_2) V_1^2 \\ &= (1/2) \times (2+4) \times 10^{-6} \times (400/3)^2 \\ &= 5.33 \times 10^{-2} \text{ J} \end{aligned}$$

Hence, amount of electrostatic energy lost by capacitor  $C_1 = E_1 - E_2$

$$= 0.08 - 0.0533 = 0.0267$$

$$= 2.67 \times 10^{-2} \text{ J}$$

**Q2.28) Show that the force on each plate of a parallel plate capacitor has a magnitude equal to  $(\frac{1}{2}) QE$ , where  $Q$  is the charge on the capacitor, and  $E$  is the magnitude of the electric field between the plates. Explain the origin of the factor  $\frac{1}{2}$ .**

**Solution:**

Let  $F$  be the force required to separate the plates of the parallel plate capacitors.

Let  $\Delta x$  be the distance between the two plates.

Therefore, the work done to separate the plates,  $W = F \Delta x$ . As a result, the potential energy of the capacitor increases by an amount equal to  $uA\Delta x$ .

here,  $u$  = energy density

$A$  = area of each plate

$d$  = distance between the plates

$V$  = potential difference across the plates

The work done will be equal to the increase in potential energy

$$F\Delta x = uA\Delta x$$

$$F = uA$$

Substituting  $u = \frac{1}{2} \epsilon_0 E^2$  in above equation

$$F = uA = \frac{1}{2} \epsilon_0 E^2 A$$

The electric intensity,  $E = V/d$

$$F = uA = \frac{1}{2} \epsilon_0 \frac{V}{d} EA$$

However, capacitance,  $C = \frac{\epsilon_0 A}{d}$

Therefore,  $F = (1/2) (CV) E$

Charge on the capacitor is given as  $Q = CV$

Therefore,  $F = (1/2)QE$

The electric field just outside the conductor is  $E$  and inside the conductor is zero. Hence, the average of the electric field  $E/2$  is equal to the force.

**Q2.29) A spherical capacitor consists of two concentric spherical conductors, held in position by suitable insulating supports (as shown in the figure). Show that the capacitance of a spherical capacitor is given by**

$$C = \frac{4\pi\epsilon_0 r_1 r_2}{r_1 - r_2}$$

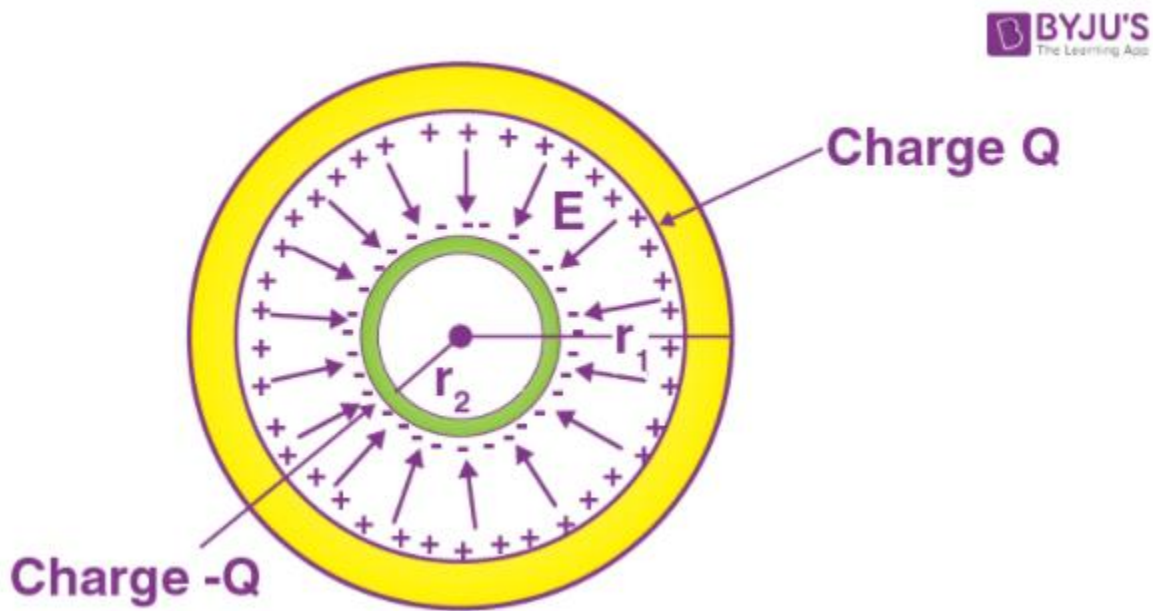

where  $r_1$  and  $r_2$  are the radii of outer and inner spheres respectively.

**Solution:**

Radius of the outer shell =  $r_1$

Radius of the inner shell =  $r_2$

The charge on the inner surface of the outer shell =  $+Q$

The charge on the outer surface of the inner shell =  $-Q$

The potential difference between the two shells is given as

$$V = \frac{Q}{4\pi\epsilon_0 r_2} - \frac{Q}{4\pi\epsilon_0 r_1}$$

Here,

$\epsilon_0$  = Permittivity of free space

$$V = \frac{Q}{4\pi\epsilon_0} \left[ \frac{1}{r_2} - \frac{1}{r_1} \right]$$

$$V = \frac{Q(r_1 - r_2)}{4\pi\epsilon_0 r_1 r_2}$$

The capacitance of the given system is

$C = \text{Charge (Q) / Potential difference (V)}$

$$\text{Therefore, } C = \frac{4\pi\epsilon_0 r_1 r_2}{(r_1 - r_2)}$$

**Q2.30)** A spherical capacitor has an inner sphere of radius 12 cm and an outer sphere of radius 13 cm. The outer sphere is earthed and the inner sphere is given a charge of 2.5  $\mu\text{C}$ . The space between the concentric spheres is filled with a liquid of dielectric constant 32.

(a) Determine the capacitance of the capacitor.

(b) What is the potential of the inner sphere?

(c) Compare the capacitance of this capacitor with that of an isolated sphere of radius 12 cm.

Explain why the latter is much smaller.

**Solution:**

Radius of the inner sphere,  $r_1 = 12 \text{ cm} = 0.12 \text{ m}$

Radius of the outer sphere,  $r_2 = 13 \text{ cm} = 0.13 \text{ m}$

Charge on the inner sphere,  $q = 2.5 \mu\text{C} = 2.5 \times 10^{-6} \text{ C}$

Dielectric constant of the liquid,  $\epsilon_r = 32$

(a) Capacitance of the capacitor is given by the relation,

$$C = \frac{4\pi\epsilon_0\epsilon_r r_1 r_2}{(r_1 - r_2)}$$

Here,

$\epsilon_0 = \text{permittivity of the free space} = 8.85 \times 10^{-12} \text{ C}^2 \text{ N}^{-1} \text{ m}^{-2}$

$$\frac{1}{4\pi\epsilon_0} = 9 \times 10^9 \text{ Nm}^2 \text{ C}^{-2}$$

Therefore,

$$C = \frac{32 \times 0.12 \times 0.13}{(9 \times 10^9 \times (0.13 - 0.12))} = 5.5 \times 10^{-9} \text{ F}$$

Therefore, the capacitance of the capacitor is approximately  $5.5 \times 10^{-9} \text{ F}$ .

(b) Potential of the inner sphere is

$$V = q/C$$

$$= (2.5 \times 10^{-6}) / (5.5 \times 10^{-9}) = 4.5 \times 10^2 \text{ V}$$

Hence the potential energy of the inner sphere is  $4.5 \times 10^2 \text{ V}$

(c) Radius of the isolated sphere,  $r = 12 \times 10^{-2} \text{ m}$

Capacitance of the isolated sphere is given by the relation,

$$C' = 4\pi\epsilon_0 r$$

$$= 4 \times 3.14 \times 8.85 \times 10^{-12} \times 12 \times 10^{-2}$$

$$= 1.333 \times 10^{-11} \text{ F}$$

The outer sphere of the concentric spheres is earthed. Therefore, the potential difference will be less for the concentric spheres and the capacitance is more than the isolated sphere.

**Q2.31) Answer carefully:**

(a) Two large conducting spheres carrying charges  $Q_1$  and  $Q_2$  are brought close to each other. Is the magnitude of the electrostatic force between them exactly given by  $Q_1 Q_2 / 4\pi\epsilon_0 r^2$ , where  $r$  is the distance between their centres?

(b) If Coulomb's law involved  $1/r^3$  dependence (instead of  $1/r^2$ ), would Gauss's law be still true?

(c) A small test charge is released at rest at a point in an electrostatic field configuration. Will it travel along the field line passing through that point?

(d) What is the work done by the field of a nucleus in a complete circular orbit of the electron? What if the orbit is elliptical?

(e) We know that the electric field is discontinuous across the surface of a charged conductor. Is electric potential also discontinuous there?

(f) What meaning would you give to the capacitance of a single conductor?

(g) Guess a possible reason why water has a much greater dielectric constant (= 80) than say, mica (= 6).

**Solution:**

(a) No, because charge distributions on the spheres will not be uniform.

(b) No.

(c) Not necessarily. (True only if the field line is a straight line.). The field line gives the direction of acceleration and not that of the velocity

(d) Zero, no matter what the shape of the complete orbit is.

(e) No, the potential is continuous.

(f) A single conductor is a capacitor with one of the 'plates' at infinity.

(g) A water molecule has a permanent dipole moment. However, a detailed explanation of the value of the dielectric constant requires microscopic theory and is beyond the scope of the book.

**Q2.32) A cylindrical capacitor has two co-axial cylinders of length 15 cm and radii 1.5 cm and 1.4 cm. The outer cylinder is earthed and the inner cylinder is given a charge of  $3.5 \mu\text{C}$ . Determine the capacitance of the system and the potential of the inner cylinder. Neglect end effects (i.e., bending of field lines at the ends).**

**Solution:**

Length of the coaxial cylinders,  $l = 15 \text{ cm} = 0.15 \text{ m}$

Radius of the outer cylinder,  $r_1 = 1.5 \text{ cm} = 0.015 \text{ m}$

Radius of the inner cylinder,  $r_2 = 1.4 \text{ cm} = 0.014 \text{ m}$

Charge of the inner cylinder,  $q = 3.5 \text{ } \mu\text{C} = 3.5 \times 10^{-6} \text{ C}$

The outer cylinder is earthed

Capacitance of the co-axial cylinder of radii  $r_1$  and  $r_2$  is given by the relation

$$C = \frac{2\pi\epsilon_0 l}{\log_e \frac{r_1}{r_2}}$$

Here,

$\epsilon_0$  is the permittivity of free space =  $8.85 \times 10^{-12} \text{ N}^{-1} \text{ m}^{-2} \text{ C}^2$

$$C = \frac{2 \times 3.14 \times 8.85 \times 10^{-12} \times 0.15}{2.3026 \log_{10} \frac{0.15}{0.14}}$$

$$C = \frac{2 \times 3.14 \times 8.85 \times 10^{-12} \times 0.15}{2.3026 \times 0.0299} = 1.2 \times 10^{-10} \text{ F}$$

Therefore, the potential difference of the inner cylinder is given by

$$V = q/C$$

$$= 3.5 \times 10^{-6} / 1.2 \times 10^{-10} = 2.92 \times 10^4 \text{ V}$$

**Q2.33) A parallel plate capacitor is to be designed with a voltage rating of 1 kV, using a material of dielectric constant 3 and dielectric strength of about  $10^7 \text{ Vm}^{-1}$ . (Dielectric strength is the maximum electric field a material can tolerate without breakdown, i.e., without starting to conduct electricity through partial ionisation.) For safety, we should like the field never to exceed, say 10% of the dielectric strength. What minimum area of the plates is required to have a capacitance of 50 pF?**

**Solution:**

Voltage rating of the parallel plate capacitor,  $V = 1 \text{ kV} = 1000 \text{ V}$ .

Dielectric constant,  $\epsilon = 3$

Dielectric strength =  $10^7 \text{ V/m}$

For safety, the field should never exceed, say 10% of the dielectric strength,  $E = 10\%$  of dielectric strength =  $(10/100) \times 10^7 = 10^6 \text{ V/m}$

Capacitance of capacitor,  $C = 50 \text{ pF} = 50 \times 10^{-12} \text{ F}$

Distance between the plates,  $d = V/E = 10^3/10^6 = 10^{-3} \text{ m}$

$$\text{Capacitance, } C = \frac{\epsilon_0 \epsilon_r A}{d}$$

$$\text{Area of the plate, } A = A = \frac{d}{\epsilon_0 \epsilon_r C}$$

$$= (50 \times 10^{-12} \times 10^{-3}) / (3 \times 8.85 \times 10^{-12})$$

$$= 1.9 \times 10^{-3} \text{ m}^2$$

$$= 19 \text{ cm}^2$$

Therefore, the minimum area of the plates,  $A = 19 \text{ cm}^2$

**Q2.34) Describe schematically the equipotential surfaces corresponding to**

**(a) a constant electric field in the z-direction,**

**(b) a field that uniformly increases in magnitude but remains in a constant (say, z) direction,**

**(c) a single positive charge at the origin, and**

**(d) a uniform grid consisting of long equally spaced parallel charged wires in a plane**

**Solution:**

(a) Planes parallel to x-y plane.

(b) Same as in (a), except that planes differing by a fixed potential get closer as the field increases.

(c) Concentric spheres centred at the origin.

(d) A periodically varying shape near the grid which gradually reaches the shape of planes parallel to the grid at far distances.

**Q2.35) A small sphere of radius  $r_1$  and charge  $q_1$  is enclosed by a spherical shell of radius  $r_2$  and charge  $q_2$ . Show that if  $q_1$  is positive, the charge will necessarily flow from the sphere to the shell (when the two are connected by a wire) no matter what the charge  $q_2$  on the shell is**

**Solution:**

By Gauss's law, the electric field between the sphere and the shell is determined only by the charge  $q_1$ . Hence, the potential difference between the sphere and the shell is independent of  $q_2$ . If  $q_1$  is positive, then the potential difference is also positive.

**Q2. 36) Answer the following:**

**(a) The top of the atmosphere is at about 400 kV with respect to the surface of the earth, corresponding to an electric field that decreases with altitude. Near the surface of the earth, the field is about  $100 \text{ Vm}^{-1}$ . Why then do we not get an electric shock as we step out of our house into the open? (Assume the house to be a steel cage so there is no field inside!)**

**(b) A man fixes outside his house one evening a two-metre high insulating slab carrying on its top a large aluminium sheet of area  $1\text{m}^2$ . Will he get an electric shock if he touches the metal sheet the next morning?**

(c) The discharging current in the atmosphere due to the small conductivity of air is known to be 1800 A on average over the globe. Why then does the atmosphere not discharge itself completely in due course and become electrically neutral? In other words, what keeps the atmosphere charged?

(d) What are the forms of energy into which the electrical energy of the atmosphere is dissipated during lightning?

(Hint: The earth has an electric field of about  $100 \text{ Vm}^{-1}$  at its surface in the downward direction, corresponding to a surface charge density  $= -10^{-9} \text{ C m}^{-2}$ . Due to the slight conductivity of the atmosphere up to about 50 km (beyond which it is good conductor), about + 1800 C is pumped every second into the earth as a whole. The earth, however, does not get discharged since thunderstorms and lightning occurring continually all over the globe pump an equal amount of negative charge on the earth.

**Solution:**

(a) Our body and the ground form an equipotential surface. As we step out into the open, the original equipotential surfaces of open-air change, keeping our head and the ground at the same potential.

(b) Yes. The steady discharging current in the atmosphere charges up the aluminium sheet gradually and raises its voltage to an extent depending on the capacitance of the capacitor (formed by the sheet, slab and the ground).

(c) The atmosphere is continually being charged by thunderstorms and lightning all over the globe and discharged through regions of ordinary weather. The two opposing currents are, on average, in equilibrium.

(d) Light energy involved in lightning; heat and sound energy in the accompanying thunder.