

SESSION - 1



EC : ELECTRONICS AND COMMUNICATION ENGINEERING*Duration:* Three Hours*Maximum Marks:* 100**Read the following instructions carefully.**

1. Do not open the seal of the Question Booklet until you are asked to do so by the invigilator.
2. Take out the **Optical Response Sheet (ORS)** from this Question Booklet **without breaking the seal** and read the instructions printed on the ORS carefully. If you find that either:
 - a. The Question Booklet Code printed at the right hand top corner of this page does not match with the Question Booklet Code at the right hand top corner of the **ORS** or
 - b. The Question Paper Code preceding the Registration number on the **ORS** is not **EC**, then exchange the booklet immediately with a new sealed Question Booklet.
3. On the right hand side of the **ORS**, using **ONLY a black ink ballpoint pen**, (i) darken the appropriate bubble under each digit of your registration number and (ii) write your registration number, your name and name of the examination centre and put your signature at the specified location.
4. This Question Booklet contains **24** pages including blank pages for rough work. After you are permitted to open the seal, check all pages and report discrepancies, if any, to the invigilator.
5. There are a total of 65 questions carrying 100 marks. All these questions are of objective type. Each question has only **one** correct answer. Questions must be answered on the left hand side of the **ORS** by darkening the appropriate bubble (marked A, B, C, D) using **ONLY a black ink ballpoint pen** against the question number. **For each question darken the bubble of the correct answer.** More than one answer bubbled against a question will be treated as an incorrect response.
6. Since bubbles darkened by the black ink ballpoint pen **cannot** be erased, candidates should darken the bubbles in the ORS **very carefully**.
7. Questions Q.1 – Q.25 carry 1 mark each. Questions Q.26 – Q.55 carry 2 marks each. The 2 marks questions include two pairs of common data questions and two pairs of linked answer questions. The answer to the second question of the linked answer questions depends on the answer to the first question of the pair. If the first question in the linked pair is wrongly answered or is not attempted, then the answer to the second question in the pair will not be evaluated.
8. Questions Q.56 – Q.65 belong to General Aptitude (GA) section and carry a total of 15 marks. Questions Q.56 – Q.60 carry 1 mark each, and questions Q.61 – Q.65 carry 2 marks each.
9. Questions not attempted will result in zero mark and wrong answers will result in **NEGATIVE** marks. For all 1 mark questions, $\frac{1}{2}$ mark will be deducted for each wrong answer. For all 2 marks questions, $\frac{2}{3}$ mark will be deducted for each wrong answer. However, in the case of the linked answer question pair, there will be negative marks only for wrong answer to the first question and no negative marks for wrong answer to the second question.
10. Calculator is allowed whereas charts, graph sheets or tables are **NOT** allowed in the examination hall.
11. Rough work can be done on the Question Booklet itself. Blank pages are provided at the end of the Question Booklet for rough work.
12. Before the start of the examination, write your name and registration number in the space provided below using a black ink ballpoint pen.

Name									
Registration Number	EC								

Q.1 to Q.25 carry one mark each.

- Q.1 A bulb in a staircase has two switches, one switch being at the ground floor and the other one at the first floor. The bulb can be turned ON and also can be turned OFF by any one of the switches irrespective of the state of the other switch. The logic of switching of the bulb resembles
- (A) an AND gate (B) an OR gate (C) an XOR gate (D) a NAND gate
- Q.2 Consider a vector field $\vec{A}(\vec{r})$. The closed loop line integral $\oint \vec{A} \cdot d\vec{l}$ can be expressed as
- (A) $\oiint (\nabla \times \vec{A}) \cdot d\vec{s}$ over the closed surface bounded by the loop
 (B) $\iiint (\nabla \cdot \vec{A}) dv$ over the closed volume bounded by the loop
 (C) $\iiint (\nabla \cdot \vec{A}) dv$ over the open volume bounded by the loop
 (D) $\iint (\nabla \times \vec{A}) \cdot d\vec{s}$ over the open surface bounded by the loop
- Q.3 Two systems with impulse responses $h_1(t)$ and $h_2(t)$ are connected in cascade. Then the overall impulse response of the cascaded system is given by
- (A) product of $h_1(t)$ and $h_2(t)$
 (B) sum of $h_1(t)$ and $h_2(t)$
 (C) convolution of $h_1(t)$ and $h_2(t)$
 (D) subtraction of $h_2(t)$ from $h_1(t)$
- Q.4 In a forward biased pn junction diode, the sequence of events that best describes the mechanism of current flow is
- (A) injection, and subsequent diffusion and recombination of minority carriers
 (B) injection, and subsequent drift and generation of minority carriers
 (C) extraction, and subsequent diffusion and generation of minority carriers
 (D) extraction, and subsequent drift and recombination of minority carriers
- Q.5 In IC technology, dry oxidation (using dry oxygen) as compared to wet oxidation (using steam or water vapor) produces
- (A) superior quality oxide with a higher growth rate
 (B) inferior quality oxide with a higher growth rate
 (C) inferior quality oxide with a lower growth rate
 (D) superior quality oxide with a lower growth rate
- Q.6 The maximum value of θ until which the approximation $\sin \theta \approx \theta$ holds to within 10% error is
- (A) 10° (B) 18° (C) 50° (D) 90°

- Q.7 The divergence of the vector field $\vec{A} = x\hat{a}_x + y\hat{a}_y + z\hat{a}_z$ is
 (A) 0 (B) 1/3 (C) 1 (D) 3
- Q.8 The impulse response of a system is $h(t) = t u(t)$. For an input $u(t-1)$, the output is
 (A) $\frac{t^2}{2} u(t)$ (B) $\frac{t(t-1)}{2} u(t-1)$ (C) $\frac{(t-1)^2}{2} u(t-1)$ (D) $\frac{t^2-1}{2} u(t-1)$
- Q.9 The Bode plot of a transfer function $G(s)$ is shown in the figure below.

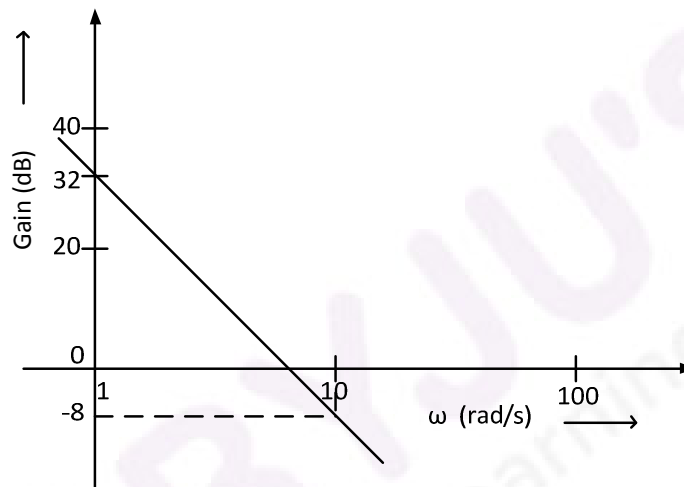

The gain ($20 \log|G(s)|$) is 32 dB and -8 dB at 1 rad/s and 10 rad/s respectively. The phase is negative for all ω . Then $G(s)$ is

- (A) $\frac{39.8}{s}$ (B) $\frac{39.8}{s^2}$ (C) $\frac{32}{s}$ (D) $\frac{32}{s^2}$
- Q.10 In the circuit shown below what is the output voltage (V_{out}) if a silicon transistor Q and an ideal op-amp are used?

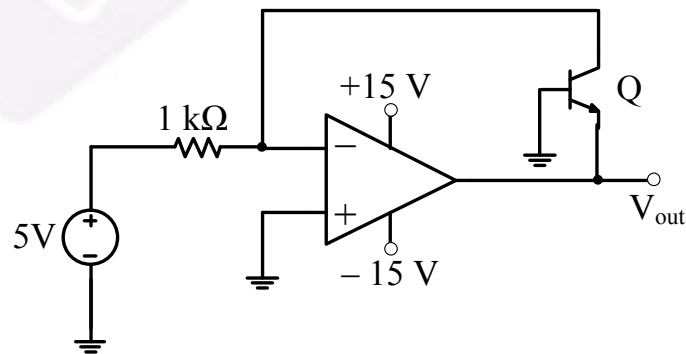

- (A) -15 V (B) -0.7 V (C) $+0.7$ V (D) $+15$ V

- Q.11 Consider a delta connection of resistors and its equivalent star connection as shown below. If all elements of the delta connection are scaled by a factor k , $k > 0$, the elements of the corresponding star equivalent will be scaled by a factor of



- (A) k^2 (B) k (C) $1/k$ (D) \sqrt{k}
- Q.12 For 8085 microprocessor, the following program is executed.
- ```

MVI A, 05H;
MVI B, 05H;
PTR: ADD B;
DCR B;
JNZ PTR;
ADI 03H;
HLT;

```
- At the end of program, accumulator contains
- (A) 17H                      (B) 20H                      (C) 23H                      (D) 05H
- Q.13 The bit rate of a digital communication system is  $R$  kbits/s. The modulation used is 32-QAM. The minimum bandwidth required for ISI free transmission is
- (A)  $R/10$  Hz                      (B)  $R/10$  kHz                      (C)  $R/5$  Hz                      (D)  $R/5$  kHz
- Q.14 For a periodic signal  $v(t) = 30 \sin 100t + 10 \cos 300t + 6 \sin (500t + \pi/4)$ , the fundamental frequency in rad/s is
- (A) 100                      (B) 300                      (C) 500                      (D) 1500

- Q.15 In a voltage-voltage feedback as shown below, which one of the following statements is TRUE if the gain  $k$  is increased?

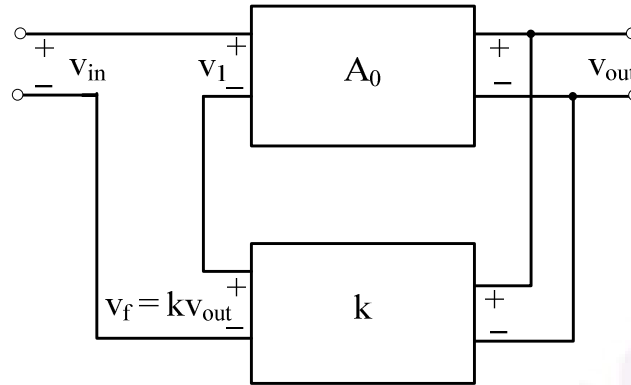

- (A) The input impedance increases and output impedance decreases.  
 (B) The input impedance increases and output impedance also increases.  
 (C) The input impedance decreases and output impedance also decreases.  
 (D) The input impedance decreases and output impedance increases.
- Q.16 A band-limited signal with a maximum frequency of 5 kHz is to be sampled. According to the sampling theorem, the sampling frequency which is not valid is  
 (A) 5 kHz                      (B) 12 kHz                      (C) 15 kHz                      (D) 20 kHz
- Q.17 In a MOSFET operating in the saturation region, the channel length modulation effect causes  
 (A) an increase in the gate-source capacitance  
 (B) a decrease in the transconductance  
 (C) a decrease in the unity-gain cutoff frequency  
 (D) a decrease in the output resistance
- Q.18 Which one of the following statements is NOT TRUE for a continuous time causal and stable LTI system?  
 (A) All the poles of the system must lie on the left side of the  $j\omega$  axis.  
 (B) Zeros of the system can lie anywhere in the  $s$ -plane.  
 (C) All the poles must lie within  $|s| = 1$ .  
 (D) All the roots of the characteristic equation must be located on the left side of the  $j\omega$  axis.
- Q.19 The minimum eigenvalue of the following matrix is
- $$\begin{bmatrix} 3 & 5 & 2 \\ 5 & 12 & 7 \\ 2 & 7 & 5 \end{bmatrix}$$
- (A) 0                      (B) 1                      (C) 2                      (D) 3

- Q.20 A polynomial  $f(x) = a_4x^4 + a_3x^3 + a_2x^2 + a_1x - a_0$  with all coefficients positive has
- (A) no real roots (B) no negative real root  
(C) odd number of real roots (D) at least one positive and one negative real root

- Q.21 Assuming zero initial condition, the response  $y(t)$  of the system given below to a unit step input  $u(t)$  is

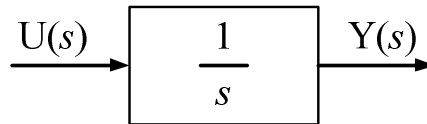

- (A)  $u(t)$  (B)  $tu(t)$  (C)  $\frac{t^2}{2}u(t)$  (D)  $e^{-t}u(t)$
- Q.22 The transfer function  $\frac{V_2(s)}{V_1(s)}$  of the circuit shown below is

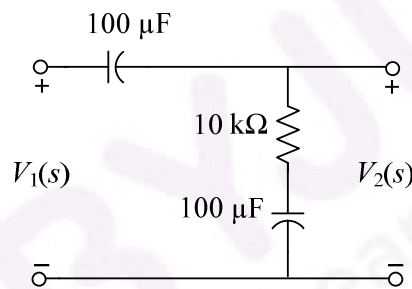

- (A)  $\frac{0.5s+1}{s+1}$  (B)  $\frac{3s+6}{s+2}$   
(C)  $\frac{s+2}{s+1}$  (D)  $\frac{s+1}{s+2}$
- Q.23 A source  $v_s(t) = V \cos 100\pi t$  has an internal impedance of  $(4 + j3) \Omega$ . If a purely resistive load connected to this source has to extract the maximum power out of the source, its value in  $\Omega$  should be
- (A) 3 (B) 4 (C) 5 (D) 7
- Q.24 The return loss of a device is found to be 20 dB. The voltage standing wave ratio (VSWR) and magnitude of reflection coefficient are respectively
- (A) 1.22 and 0.1 (B) 0.81 and 0.1 (C) -1.22 and 0.1 (D) 2.44 and 0.2
- Q.25 Let  $g(t) = e^{-\pi t^2}$ , and  $h(t)$  is a filter matched to  $g(t)$ . If  $g(t)$  is applied as input to  $h(t)$ , then the Fourier transform of the output is
- (A)  $e^{-\pi f^2}$  (B)  $e^{-\pi f^2/2}$  (C)  $e^{-\pi|f|}$  (D)  $e^{-2\pi f^2}$

**Q.26 to Q.55 carry two marks each.**

Q.26 Let  $U$  and  $V$  be two independent zero mean Gaussian random variables of variances  $\frac{1}{4}$  and  $\frac{1}{9}$  respectively. The probability  $P(3V \geq 2U)$  is

- (A) 4/9                      (B) 1/2                      (C) 2/3                      (D) 5/9

Q.27 Let  $A$  be an  $m \times n$  matrix and  $B$  an  $n \times m$  matrix. It is given that determinant  $(I_m + AB) =$  determinant  $(I_n + BA)$ , where  $I_k$  is the  $k \times k$  identity matrix. Using the above property, the determinant of the matrix given below is

$$\begin{bmatrix} 2 & 1 & 1 & 1 \\ 1 & 2 & 1 & 1 \\ 1 & 1 & 2 & 1 \\ 1 & 1 & 1 & 2 \end{bmatrix}$$

- (A) 2                      (B) 5                      (C) 8                      (D) 16

Q.28 In the circuit shown below, if the source voltage  $V_s = 100\angle 53.13^\circ$  V then the Thevenin's equivalent voltage in Volts as seen by the load resistance  $R_L$  is

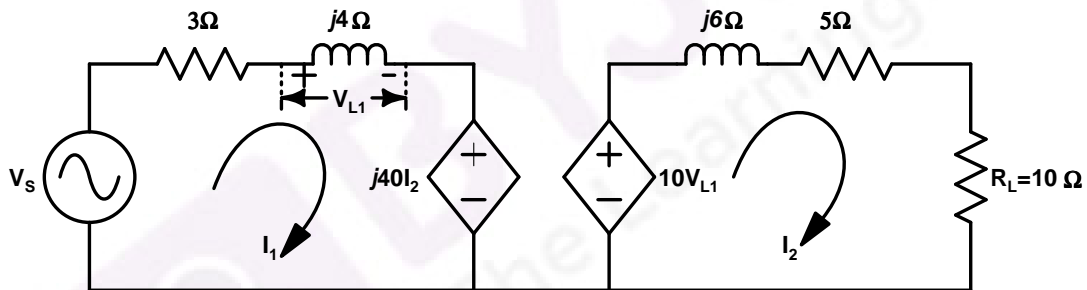

- (A)  $100\angle 90^\circ$                       (B)  $800\angle 0^\circ$                       (C)  $800\angle 90^\circ$                       (D)  $100\angle 60^\circ$

Q.29 The open-loop transfer function of a dc motor is given as  $\frac{\omega(s)}{V_a(s)} = \frac{10}{1+10s}$ . When connected in feedback as shown below, the approximate value of  $K_a$  that will reduce the time constant of the closed loop system by one hundred times as compared to that of the open-loop system is

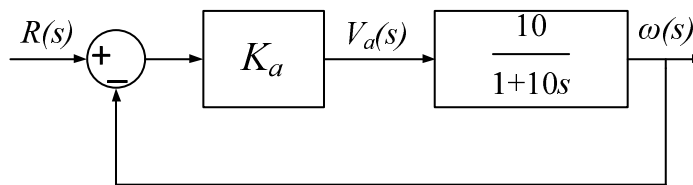

- (A) 1                      (B) 5                      (C) 10                      (D) 100



- Q.30 In the circuit shown below, the knee current of the ideal Zener diode is 10 mA. To maintain 5 V across  $R_L$ , the minimum value of  $R_L$  in  $\Omega$  and the minimum power rating of the Zener diode in mW, respectively, are

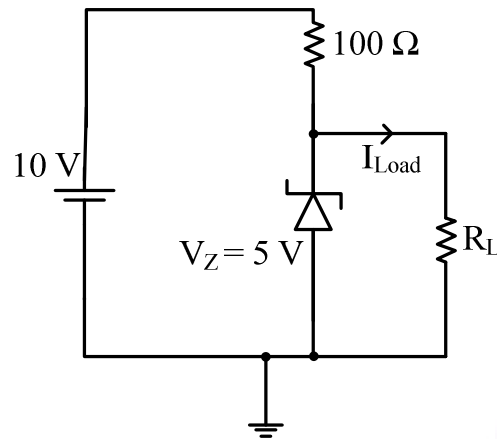

- (A) 125 and 125  
 (B) 125 and 250  
 (C) 250 and 125  
 (D) 250 and 250
- Q.31 The following arrangement consists of an ideal transformer and an attenuator which attenuates by a factor of 0.8. An ac voltage  $V_{WX1} = 100V$  is applied across WX to get an open circuit voltage  $V_{YZ1}$  across YZ. Next, an ac voltage  $V_{YZ2} = 100V$  is applied across YZ to get an open circuit voltage  $V_{WX2}$  across WX. Then,  $V_{YZ1}/V_{WX1}$ ,  $V_{WX2}/V_{YZ2}$  are respectively,

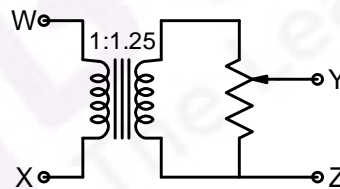

- (A) 125/100 and 80/100  
 (B) 100/100 and 80/100  
 (C) 100/100 and 100/100  
 (D) 80/100 and 80/100
- Q.32 Two magnetically uncoupled inductive coils have  $Q$  factors  $q_1$  and  $q_2$  at the chosen operating frequency. Their respective resistances are  $R_1$  and  $R_2$ . When connected in series, their effective  $Q$  factor at the same operating frequency is
- (A)  $q_1 + q_2$   
 (B)  $(1/q_1) + (1/q_2)$   
 (C)  $(q_1 R_1 + q_2 R_2) / (R_1 + R_2)$   
 (D)  $(q_1 R_2 + q_2 R_1) / (R_1 + R_2)$
- Q.33 The impulse response of a continuous time system is given by  $h(t) = \delta(t-1) + \delta(t-3)$ . The value of the step response at  $t = 2$  is
- (A) 0  
 (B) 1  
 (C) 2  
 (D) 3

- Q.34 The small-signal resistance (i.e.,  $dV_B/dI_D$ ) in  $k\Omega$  offered by the  $n$ -channel MOSFET M shown in the figure below, at a bias point of  $V_B = 2$  V is (device data for M: device transconductance parameter  $k_N = \mu_n C'_{ox} (W/L) = 40 \mu A/V^2$ , threshold voltage  $V_{TN} = 1$  V, and neglect body effect and channel length modulation effects)

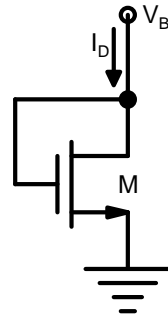

- (A) 12.5                      (B) 25                      (C) 50                      (D) 100

- Q.35 The ac schematic of an NMOS common-source stage is shown in the figure below, where part of the biasing circuits has been omitted for simplicity. For the  $n$ -channel MOSFET M, the transconductance  $g_m = 1$  mA/V, and body effect and channel length modulation effect are to be neglected. The lower cutoff frequency in Hz of the circuit is approximately at

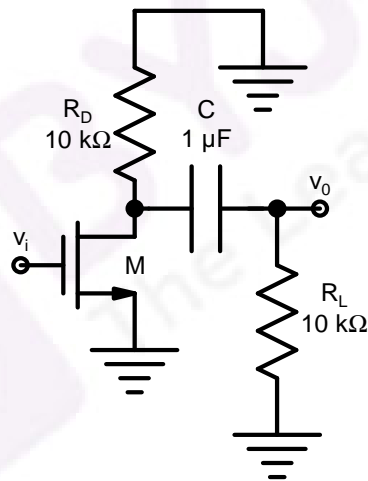

- (A) 8                      (B) 32                      (C) 50                      (D) 200

- Q.36 A system is described by the differential equation  $\frac{d^2y}{dt^2} + 5\frac{dy}{dt} + 6y(t) = x(t)$ .

Let  $x(t)$  be a rectangular pulse given by

$$x(t) = \begin{cases} 1 & 0 < t < 2 \\ 0 & \text{otherwise} \end{cases}$$

Assuming that  $y(0) = 0$  and  $\frac{dy}{dt} = 0$  at  $t = 0$ , the Laplace transform of  $y(t)$  is

- (A)  $\frac{e^{-2s}}{s(s+2)(s+3)}$                       (B)  $\frac{1-e^{-2s}}{s(s+2)(s+3)}$   
 (C)  $\frac{e^{-2s}}{(s+2)(s+3)}$                       (D)  $\frac{1-e^{-2s}}{(s+2)(s+3)}$

- Q.37 A system described by a linear, constant coefficient, ordinary, first order differential equation has an exact solution given by  $y(t)$  for  $t > 0$ , when the forcing function is  $x(t)$  and the initial condition is  $y(0)$ . If one wishes to modify the system so that the solution becomes  $-2y(t)$  for  $t > 0$ , we need to

- (A) change the initial condition to  $-y(0)$  and the forcing function to  $2x(t)$   
 (B) change the initial condition to  $2y(0)$  and the forcing function to  $-x(t)$   
 (C) change the initial condition to  $j\sqrt{2}y(0)$  and the forcing function to  $j\sqrt{2}x(t)$   
 (D) change the initial condition to  $-2y(0)$  and the forcing function to  $-2x(t)$

- Q.38 Consider two identically distributed zero-mean random variables  $U$  and  $V$ . Let the cumulative distribution functions of  $U$  and  $2V$  be  $F(x)$  and  $G(x)$  respectively. Then, for all values of  $x$

- (A)  $F(x) - G(x) \leq 0$                       (B)  $F(x) - G(x) \geq 0$   
 (C)  $(F(x) - G(x)) \cdot x \leq 0$                       (D)  $(F(x) - G(x)) \cdot x \geq 0$

- Q.39 The DFT of a vector  $[a \ b \ c \ d]$  is the vector  $[\alpha \ \beta \ \gamma \ \delta]$ . Consider the product

$$[p \ q \ r \ s] = [a \ b \ c \ d] \begin{bmatrix} a & b & c & d \\ d & a & b & c \\ c & d & a & b \\ b & c & d & a \end{bmatrix}.$$

The DFT of the vector  $[p \ q \ r \ s]$  is a scaled version of

- (A)  $[\alpha^2 \ \beta^2 \ \gamma^2 \ \delta^2]$                       (B)  $[\sqrt{\alpha} \ \sqrt{\beta} \ \sqrt{\gamma} \ \sqrt{\delta}]$   
 (C)  $[\alpha+\beta \ \beta+\delta \ \delta+\gamma \ \gamma+\alpha]$                       (D)  $[\alpha \ \beta \ \gamma \ \delta]$

Q.40 The signal flow graph for a system is given below. The transfer function  $\frac{Y(s)}{U(s)}$  for this system is

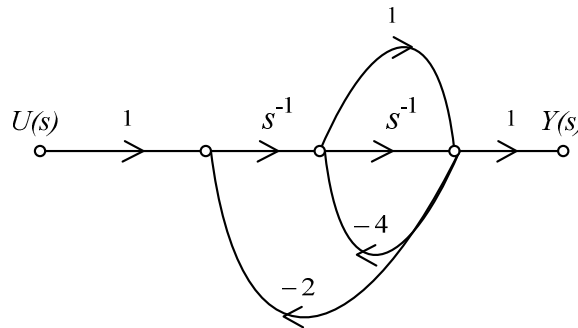

- (A)  $\frac{s+1}{5s^2+6s+2}$
- (B)  $\frac{s+1}{s^2+6s+2}$
- (C)  $\frac{s+1}{s^2+4s+2}$
- (D)  $\frac{1}{5s^2+6s+2}$

Q.41 In the circuit shown below the op-amps are ideal. Then  $V_{out}$  in Volts is

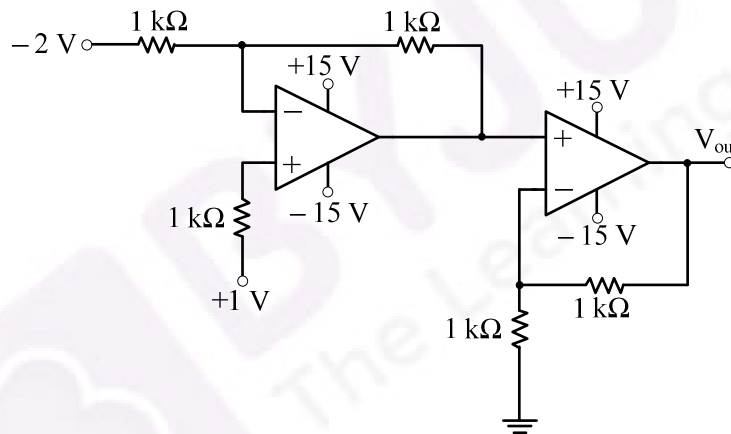

- (A) 4
- (B) 6
- (C) 8
- (D) 10

Q.42 In the circuit shown below,  $Q_1$  has negligible collector-to-emitter saturation voltage and the diode drops negligible voltage across it under forward bias. If  $V_{cc}$  is +5 V, X and Y are digital signals with 0 V as logic 0 and  $V_{cc}$  as logic 1, then the Boolean expression for Z is

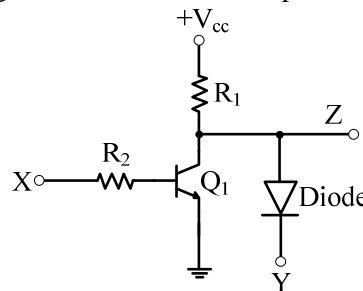

- (A) XY
- (B)  $\bar{X}Y$
- (C)  $X\bar{Y}$
- (D)  $\bar{X}\bar{Y}$

- Q.43 A voltage  $1000 \sin \omega t$  Volts is applied across YZ. Assuming ideal diodes, the voltage measured across WX in Volts, is

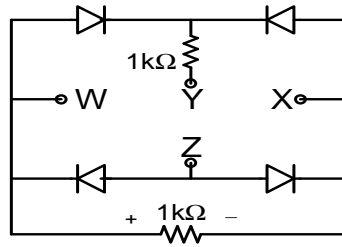

- (A)  $\sin \omega t$  (B)  $(\sin \omega t + |\sin \omega t|) / 2$   
 (C)  $(\sin \omega t - |\sin \omega t|) / 2$  (D) 0 for all  $t$
- Q.44 Three capacitors  $C_1$ ,  $C_2$  and  $C_3$  whose values are  $10\mu\text{F}$ ,  $5\mu\text{F}$ , and  $2\mu\text{F}$  respectively, have breakdown voltages of 10V, 5V, and 2V respectively. For the interconnection shown below, the maximum safe voltage in Volts that can be applied across the combination, and the corresponding total charge in  $\mu\text{C}$  stored in the effective capacitance across the terminals are respectively,

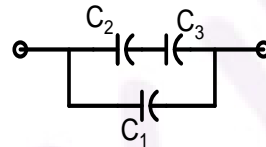

- (A) 2.8 and 36 (B) 7 and 119  
 (C) 2.8 and 32 (D) 7 and 80

- Q.45 There are four chips each of 1024 bytes connected to a 16 bit address bus as shown in the figure below. RAMs 1, 2, 3 and 4 respectively are mapped to addresses

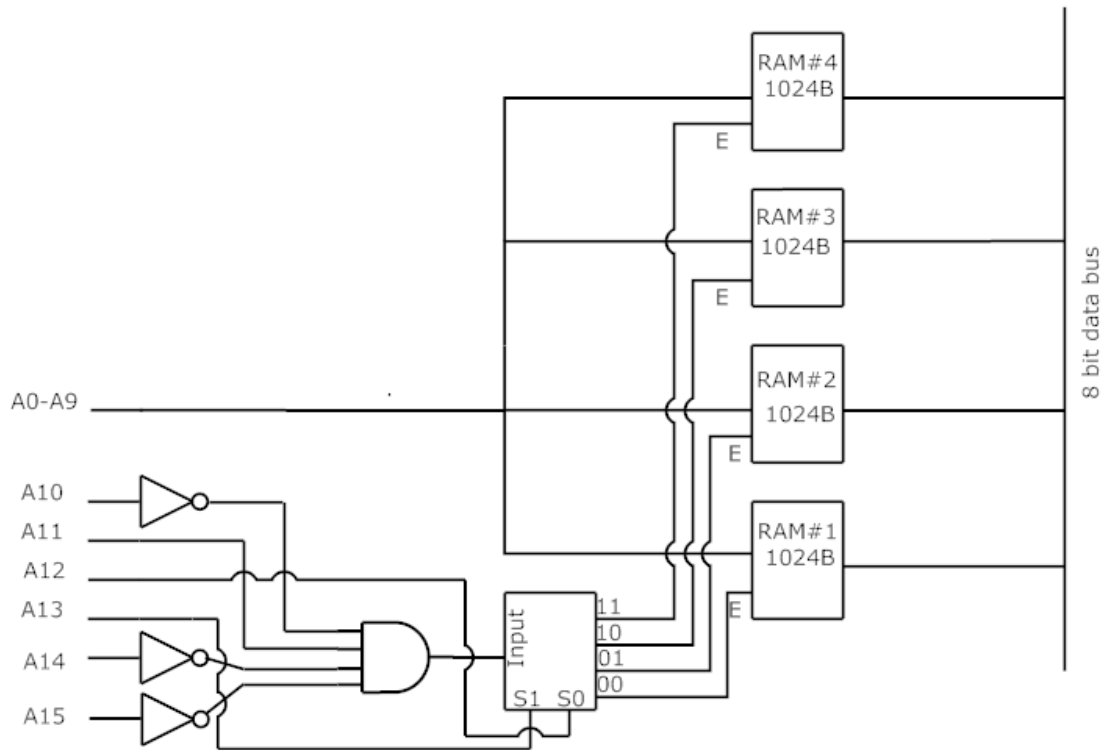

- (A) 0C00H-0FFFH, 1C00H-1FFFH, 2C00H-2FFFH, 3C00H-3FFFH  
 (B) 1800H-1FFFH, 2800H-2FFFH, 3800H-3FFFH, 4800H-4FFFH  
 (C) 0500H-08FFH, 1500H-18FFH, 3500H-38FFH, 5500H-58FFH  
 (D) 0800H-0BFFH, 1800H-1BFFH, 2800H-2BFFH, 3800H-3BFFH

- Q.46 In the circuit shown below, the silicon npn transistor Q has a very high value of  $\beta$ . The required value of  $R_2$  in  $k\Omega$  to produce  $I_C = 1$  mA is

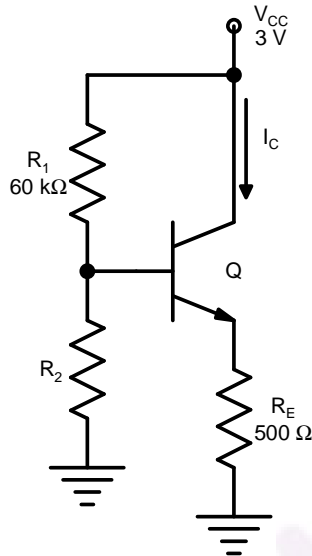

- (A) 20                      (B) 30                      (C) 40                      (D) 50
- Q.47 Let  $U$  and  $V$  be two independent and identically distributed random variables such that  $P(U = +1) = P(U = -1) = \frac{1}{2}$ . The entropy  $H(U + V)$  in bits is
- (A)  $3/4$                       (B) 1                      (C)  $3/2$                       (D)  $\log_2 3$

### Common Data Questions

#### Common Data for Questions 48 and 49:

Bits 1 and 0 are transmitted with equal probability. At the receiver, the pdf of the respective received signals for both bits are as shown below.

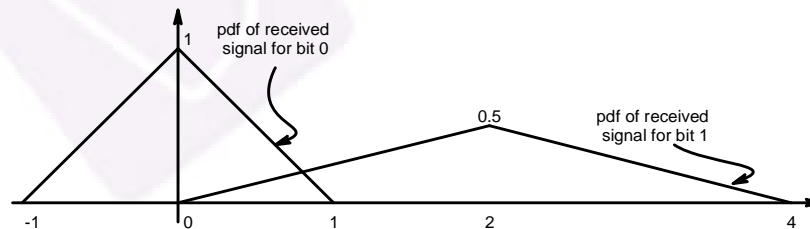

- Q.48 If the detection threshold is 1, the BER will be
- (A)  $\frac{1}{2}$                       (B)  $\frac{1}{4}$                       (C)  $\frac{1}{8}$                       (D)  $\frac{1}{16}$
- Q.49 The optimum threshold to achieve minimum bit error rate (BER) is
- (A)  $\frac{1}{2}$                       (B)  $\frac{4}{5}$                       (C) 1                      (D)  $\frac{3}{2}$

**Common Data for Questions 50 and 51:**

Consider the following figure

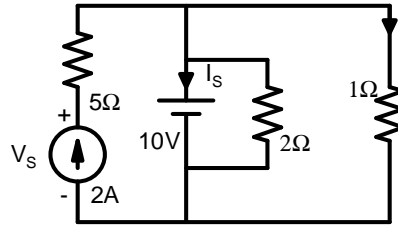

Q.50 The current  $I_S$  in Amps in the voltage source, and voltage  $V_S$  in Volts across the current source respectively, are

- (A) 13, -20                      (B) 8, -10                      (C) -8, 20                      (D) -13, 20

Q.51 The current in the  $1\Omega$  resistor in Amps is

- (A) 2                      (B) 3.33                      (C) 10                      (D) 12

**Linked Answer Questions****Statement for Linked Answer Questions 52 and 53:**

A monochromatic plane wave of wavelength  $\lambda = 600\mu\text{m}$  is propagating in the direction as shown in the figure below.  $\vec{E}_i$ ,  $\vec{E}_r$ , and  $\vec{E}_t$  denote incident, reflected, and transmitted electric field vectors associated with the wave.

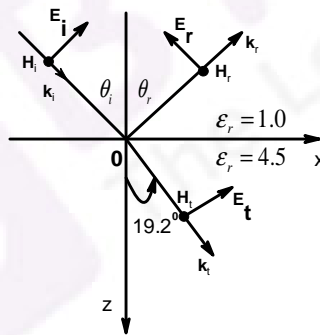

Q.52 The angle of incidence  $\theta_i$  and the expression for  $\vec{E}_i$  are

- (A)  $60^\circ$  and  $\frac{E_0}{\sqrt{2}}(\hat{a}_x - \hat{a}_z)e^{-j\frac{\pi \times 10^4}{3\sqrt{2}}(x+z)}$  V/m
- (B)  $45^\circ$  and  $\frac{E_0}{\sqrt{2}}(\hat{a}_x + \hat{a}_z)e^{-j\frac{\pi \times 10^4}{3}z}$  V/m
- (C)  $45^\circ$  and  $\frac{E_0}{\sqrt{2}}(\hat{a}_x - \hat{a}_z)e^{-j\frac{\pi \times 10^4}{3\sqrt{2}}(x+z)}$  V/m
- (D)  $60^\circ$  and  $\frac{E_0}{\sqrt{2}}(\hat{a}_x - \hat{a}_z)e^{-j\frac{\pi \times 10^4}{3}z}$  V/m



Q.53 The expression for  $\vec{E}_r$  is

- (A)  $0.23 \frac{E_0}{\sqrt{2}} (\hat{a}_x + \hat{a}_z) e^{-j \frac{\pi \times 10^4 (x-z)}{3\sqrt{2}}} \text{ V/m}$
- (B)  $-\frac{E_0}{\sqrt{2}} (\hat{a}_x + \hat{a}_z) e^{j \frac{\pi \times 10^4 z}{3}} \text{ V/m}$
- (C)  $0.44 \frac{E_0}{\sqrt{2}} (\hat{a}_x + \hat{a}_z) e^{-j \frac{\pi \times 10^4 (x-z)}{3\sqrt{2}}} \text{ V/m}$
- (D)  $\frac{E_0}{\sqrt{2}} (\hat{a}_x + \hat{a}_z) e^{-j \frac{\pi \times 10^4 (x+z)}{3}} \text{ V/m}$

**Statement for Linked Answer Questions 54 and 55:**

The state diagram of a system is shown below. A system is described by the state-variable equations

$$\dot{\mathbf{X}} = \mathbf{A}\mathbf{X} + \mathbf{B}u; \quad y = \mathbf{C}\mathbf{X} + \mathbf{D}u$$

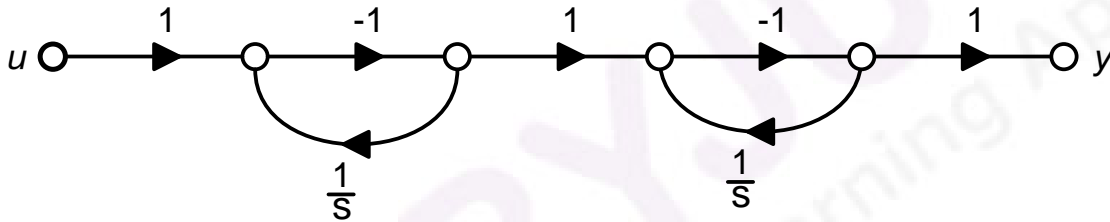

Q.54 The state-variable equations of the system shown in the figure above are

- (A)  $\dot{\mathbf{X}} = \begin{bmatrix} -1 & 0 \\ 1 & -1 \end{bmatrix} \mathbf{X} + \begin{bmatrix} -1 \\ 1 \end{bmatrix} u$   
 $y = [1 \quad -1] \mathbf{X} + u$
- (B)  $\dot{\mathbf{X}} = \begin{bmatrix} -1 & 0 \\ -1 & -1 \end{bmatrix} \mathbf{X} + \begin{bmatrix} -1 \\ 1 \end{bmatrix} u$   
 $y = [-1 \quad -1] \mathbf{X} + u$
- (C)  $\dot{\mathbf{X}} = \begin{bmatrix} -1 & 0 \\ -1 & -1 \end{bmatrix} \mathbf{X} + \begin{bmatrix} -1 \\ 1 \end{bmatrix} u$   
 $y = [-1 \quad -1] \mathbf{X} - u$
- (D)  $\dot{\mathbf{X}} = \begin{bmatrix} -1 & -1 \\ 0 & -1 \end{bmatrix} \mathbf{X} + \begin{bmatrix} -1 \\ 1 \end{bmatrix} u$   
 $y = [1 \quad -1] \mathbf{X} - u$

Q.55 The state transition matrix  $e^{\mathbf{A}t}$  of the system shown in the figure above is

- (A)  $\begin{bmatrix} e^{-t} & 0 \\ te^{-t} & e^{-t} \end{bmatrix}$
- (B)  $\begin{bmatrix} e^{-t} & 0 \\ -te^{-t} & e^{-t} \end{bmatrix}$
- (C)  $\begin{bmatrix} e^{-t} & 0 \\ e^{-t} & e^{-t} \end{bmatrix}$
- (D)  $\begin{bmatrix} e^{-t} & -te^{-t} \\ 0 & e^{-t} \end{bmatrix}$

**General Aptitude (GA) Questions****Q.56 to Q.60 carry one mark each.**

Q.56 Choose the grammatically **CORRECT** sentence:

- (A) Two and two add four.
- (B) Two and two become four.
- (C) Two and two are four.
- (D) Two and two make four.

Q.57 **Statement:** You can always give me a ring whenever you need.

Which one of the following is the best inference from the above statement?

- (A) Because I have a nice caller tune.
- (B) Because I have a better telephone facility.
- (C) Because a friend in need is a friend indeed.
- (D) Because you need not pay towards the telephone bills when you give me a ring.

Q.58 In the summer of 2012, in New Delhi, the mean temperature of Monday to Wednesday was 41°C and of Tuesday to Thursday was 43°C. If the temperature on Thursday was 15% higher than that of Monday, then the temperature in °C on Thursday was

- (A) 40
- (B) 43
- (C) 46
- (D) 49

Q.59 Complete the sentence:

Dare \_\_\_\_\_ mistakes.

- (A) commit
- (B) to commit
- (C) committed
- (D) committing

Q.60 They were requested not to **quarrel** with others.

Which one of the following options is the closest in meaning to the word **quarrel**?

- (A) make out
- (B) call out
- (C) dig out
- (D) fall out

**Q.61 to Q.65 carry two marks each.**

Q.61 A car travels 8 km in the first quarter of an hour, 6 km in the second quarter and 16 km in the third quarter. The average speed of the car in km per hour over the entire journey is

- (A) 30
- (B) 36
- (C) 40
- (D) 24

Q.62 Find the sum to  $n$  terms of the series  $10+84+ 734 + \dots$

- (A)  $\frac{9(9^n + 1)}{10} + 1$
- (B)  $\frac{9(9^n - 1)}{8} + 1$
- (C)  $\frac{9(9^n - 1)}{8} + n$
- (D)  $\frac{9(9^n - 1)}{8} + n^2$

Q.63 **Statement:** There were different streams of freedom movements in colonial India carried out by the moderates, liberals, radicals, socialists, and so on.

Which one of the following is the best inference from the above statement?

- (A) The emergence of nationalism in colonial India led to our Independence.
- (B) Nationalism in India emerged in the context of colonialism.
- (C) Nationalism in India is homogeneous.
- (D) Nationalism in India is heterogeneous.

Q.64 The set of values of  $p$  for which the roots of the equation  $3x^2+2x+p(p-1) = 0$  are of opposite sign is

- (A)  $(-\infty, 0)$                       (B)  $(0, 1)$                       (C)  $(1, \infty)$                       (D)  $(0, \infty)$

Q.65 What is the chance that a leap year, selected at random, will contain 53 Saturdays?

- (A)  $2/7$                       (B)  $3/7$                       (C)  $1/7$                       (D)  $5/7$

**END OF THE QUESTION PAPER**