

**ISC SEMESTER 1 EXAMINATION**  
**SPECIMEN QUESTION PAPER**  
**BIOLOGY**  
**PAPER 1**  
**(THEORY)**

---

*Maximum Marks: 70*

*Time allowed: One and a half hours*

*(Candidates are allowed additional 15 minutes for only reading the paper.)*

**ALL QUESTIONS ARE COMPULSORY**

*Each Question / Subpart of a question carries one mark.*

---

*Select the correct option for each of the following questions.*

---

Answer the questions given below by choosing the correct option

**Question 1**

Which of the following steps in transcription is catalysed by RNA polymerase?

- (a) Initiation
- (b) Elongation
- (c) Termination
- (d) All of the above

**Question 2**

In a DNA strand the nucleotides are linked together by

- (a) glycosidic bonds
- (b) phosphodiester bonds
- (c) peptide bonds
- (d) hydrogen bonds

**Question 3**

If the sequence of nitrogen bases of the coding strand of DNA in a transcription unit is: 5' – ATGAATG – 3', the sequence of bases in its RNA transcript would be:

- (a) 5' – AUG A AUG – 3'
- (b) 5' – UACUU AC – 3'
- (c) 5' – CAUUCAU – 3'
- (d) 5' – GUAAGUA – 3'

**Question 4**

In *E. coli* the lac operon gets switched on when

- (a) lactose is present and it binds to the repressor
- (b) repressor binds to operator
- (c) RNA polymerase binds to the operator
- (d) lactose is present and it binds to RNA polymerase

**Question 5**

The amino acid attaches to the tRNA at its

- (a) 5'- end
- (b) 3' – end
- (c) anticodon site
- (d) DHU loop

**Question 6**

Which of the following provides the most satisfactory evidence in the favour of the organic evolution?

- (a) Fossils
- (b) Neoteny
- (c) Connecting links
- (d) None of above

**Question 7**

Which era is dubbed as the age of prokaryotic microbes?

- (a) Phanerozoic
- (b) Proterozoic
- (c) Precambrian
- (d) Archeozoic

**Question 8**

The presence of gill slits in the embryos of all vertebrates supports the theory of:

- (a) Recapitulation
- (b) Organic evolution
- (c) Metamorphosis
- (d) Biogenesis

**Question 9**

In Miller's experiment, the gaseous mixture in the flask contained:

- (a) Methane, ammonia, carbon dioxide and helium
- (b) Carbon dioxide, hydrogen, water vapour and ammonia
- (c) Ammonia, methane, hydrogen and water vapour
- (d) Hydrogen, ammonia and methane and helium

**Question 10**

Neo-Darwinism is:

- (a) Natural selection theory
- (b) Modern mutation theory
- (c) Modern synthetic theory
- (d) Population theory

**Question 11**

Trichoderma, free living fungi, present in root ecosystem are useful as:

- (a) Biofertilizer
- (b) Biopesticides
- (c) Methanogens
- (d) Vector for genetic engineering

**Question 12**

During spermatogenesis, the second maturation division results in the formation of:

- (a) 8 haploid spermatids
- (b) 2 diploid spermatids
- (c) 4 haploid spermatids
- (d) 16 haploid spermatids

**Question 13**

What is the effect of high pH on sperm?

- (a) High activity leading to early death
- (b) Sluggish, longer life
- (c) High activity, longer life
- (d) No effect

**Question 14**

If temperature is reduced to 0°C, what will happen to spermatozoa?

- (a) All will die
- (b) No change
- (c) Shedding of tail
- (d) Temporary inactivation

**Question 15**

Select the incorrect statement about gametes:

- (a) Sperm begin developing before puberty
- (b) Sperm do not develop successfully at 37°C
- (c) Sperm are made in the seminiferous tubules
- (d) Sperm are capable of movement

**Question 16**

In industries, citric acid is obtained from which of the following the microbe?

- (a) *Aspergillus niger*
- (b) *Clostridium botulinum*
- (c) *Saccharomyces cerevisiae*
- (d) *Trichoderma polysporum*

**Question 17**

Statins are used as:

- (a) Clot busters
- (b) Clearing of fruit juices
- (c) Blood cholesterol lowering agents
- (d) Meat tenderisers

**Question 18**

Biological name of the common yeast used in baking industry is:

- (a) *Saccharomyces cerevisiae*
- (b) *Clostridium butylicum*
- (c) *Trichoderma polysporum*
- (d) *Propionibacterium shermanii*

**Question 19**

Which of the following microbes is used in the production of Swiss cheese?

- (a) *Aspergillus niger*
- (b) *Mucor*
- (c) *Monascus purpureus*
- (d) *Penicillium notatum*

**Question 20**

Which of the following can be used as biofertilizer?

- (a) Anabaena
- (b) Nostoc
- (c) Oscillatoria
- (d) All the above

**Question 21**

The abbreviation 'HIV' stands for:

- (a) Human immune virus
- (b) Hepatitis virus
- (c) Human Immuno deficiency virus
- (d) Highly infectious virus

**Question 22**

The abbreviation snRNA stands for:

- (a) Small nuclear RNA
- (b) Small nucleus and RNA
- (c) Small nucleolar RNA
- (d) Sub-nuclear RNA

**Question 23**

The fact that DNA is the genetic material was proved by:

- (a) Meselson and Stahl
- (b) Sutton and Boveri
- (c) Watson and Crick
- (d) Hershey and Chase

**Question 24**

The term biodiversity was coined by:

- (a) Wilson
- (b) R Mishra
- (c) Rio de Janeiro
- (d) Oparin

**Question 25**

Bt cotton is a/an \_\_\_\_\_ resistant variety of cotton.

- (a) Insecticide
- (b) Pest
- (c) Insect
- (d) Disease

**Question 26**

Bt cotton has been produced by transferring genes of \_\_\_\_\_ into the cotton plant.

- (a) *Escherichia coli*
- (b) *Pseudomonas putida*
- (c) *Bacillus tumorigenes*
- (d) *Bacillus thuringiensis*

**Question 27**

The enzyme pectinase is obtained from:

- (a) *Bacillus aureus*
- (b) *Bacillus cereus*
- (c) *Trichoderma*
- (d) *Claviceps*

**Question 28**

The enzyme \_\_\_ is used to remove the turbidity and clear the fruit juices:

- (a) Zymase
- (b) Pectinase
- (c) Amylase
- (d) Papain

**Question 29**

Secondary sewage treatment is mainly a \_\_\_ process:

- (a) Chemical
- (b) biological
- (c) mechanical
- (d) physical

**Question 30**

Corpus luteum has \_\_\_ function:

- (a) Reproductive
- (b) Endocrine
- (c) Excretory
- (d) All the above

**Question 31**

The hormone \_(A)\_, released by \_(B)\_ helps in the release of milk from the mammary glands

- (a) Oxytocin, placenta
- (b) Prolactin, posterior pituitary
- (c) Prolactin, ovary
- (d) Oxytocin, posterior pituitary

**Question 32**

If the mother is homozygous for blood group B, and the father is heterozygous for blood group A, their offspring will be of \_\_\_ and \_\_\_ blood groups:

- (a) A, B
- (b) O, B
- (c) B, AB
- (d) A, AB

**Question 33**

The vermiform appendix is \_\_\_\_ organ in humans.

- (a) A homologous
- (b) An analogous
- (c) A vestigial
- (d) An over-specialised

**Question 34**

The sperm of *Drosophila* contains \_\_\_\_\_ number of chromosomes:

- (a) 4
- (b) 46
- (c) 23
- (d) 8

**Question 35**

Which of the following is not correct regarding vasectomy?

- (a) It is irreversible
- (b) It causes loss of secondary sexual characters in males
- (c) It leads to absence of sperm in the semen
- (d) This process involves bilateral cutting and ligating of the sperm ducts

**Question 36.**

Which of the following statements is correct?

- (a) Down's syndrome is caused due to trisomy of 22nd chromosome
- (b) Haemophilia is an autosomal recessive disorder
- (c) The life on the Earth appeared about 3.5 million years ago
- (d) In angiosperms, the endosperm is triploid

**Question 37**

Identify the correct match from the columns and mark the correct option:

A	Leydig cells	p	Extra embryonic mesoderm	i	ABP
B	Primordial germ cell	q	Interstitial space	ii	Upto puberty no development
C	Spermatogonia	r	Germ cell of testis	iii	During embryonic life
D	Sertoli cell of testis	s	Nurse cell	iv	Testosterone

- (a) A-q-iv, B-p-iii, C-r-ii, D-s-i
- (b) A-s-iv, B-p-iii, C-q-ii, D-r-i
- (c) A-q-i, B-r-ii, C-s-iii, D-p-iv
- (d) A-q-iv, B-r-ii, C-p-i, D-s-iii

### Question 38

Match Column – I with Column – II and select the correct option from the choices given below:

	Column – I (Microbe)	Column – II (Product)
(a)	<i>Saccharomyces cerevisiae</i>	Ethanol
(b)	<i>Monascus purpureus</i>	Lipase
(c)	<i>Clostridium</i>	Statins
(d)	<i>Penicillium</i>	Butyric acid

Matching codes:

- (a) A-3, B-1, C-2, D-4
- (b) A-1, B-4, C-3, D-2
- (c) A-2, B-1, C-4, D-43
- (d) A-4, B-3, C-2, D-1

### Question 39

Which of the following is odd one out with reference to evolution?

- (a) Flippers of whale
- (b) Wings of pigeon
- (c) Forelimbs of rabbit
- (d) Wings of butterfly

### Question 40

Which of the following is odd one out with reference to geological time scale?

- (a) Proterozoic
- (b) Mesozoic
- (c) Jurassic
- (d) Coenozoic

### Question 41

**Assertion:** All the plants belonging to a single clone are phenotypically identical

**Reason:** All the plants within a clone are derived from vegetative cells through mitosis and have the same genetic constitution.

- (a) Both assertion and reason are true, and reason is the correct explanation of assertion.
- (b) Both assertion and reason are true, but reason is not the correct explanation of assertion.
- (c) Assertion is true but reason is false.
- (d) Both assertion and reason are false.



#### Question 42

**Assertion:** - Autosomal disease is transferred from father to both son and daughter.

**Reason:** - Autosomes are transferred only from father to son.

- (a) Both assertion and reason are true, and reason is the correct explanation of assertion.
- (b) Both assertion and reason are true, but reason is not the correct explanation of assertion.
- (c) Assertion is true but reason is false.
- (d) Both assertion and reason are false.

#### Question 43

**Assertion:** Tropical latitudes have greater biological diversity temperate latitudes.

**Reason:** Tropical regions remain relatively undisturbed for millions of years.

- (a) Both assertion and reason are true, and reason is the correct explanation of assertion.
- (b) Both assertion and reason are true, but reason is not the correct explanation of assertion.
- (c) Assertion is true but reason is false.
- (d) Both assertion and reason are false.

#### Question 44

**Assertion:** Methane component of greenhouse gases contributing to global warming is about 20%.

**Reason:** Introduction of multi-point fuel injection increase methane production. engines in automobiles has decreased methane content in the exhausts.

- (a) Both assertion and reason are true, and reason is the correct explanation of assertion.
- (b) Both assertion and reason are true, but reason is not the correct explanation of assertion.
- (c) Assertion is true but reason is false.
- (d) Both assertion and reason are false.

#### Question 45

**Assertion:** - Mendel conducted his experiments on *Pisum Sativum*.

**Reason:** - *Pisum Sativum* belongs the family *Solanaceae*.

- (a) Both assertion and reason are true, and reason is the correct explanation of assertion.
- (b) Both assertion and reason are true, but reason is not the correct explanation of assertion.
- (c) Assertion is true but reason is false.
- (d) Both assertion and reason are false.

### Question 46

Study the diagram given below and answer the questions that follow:

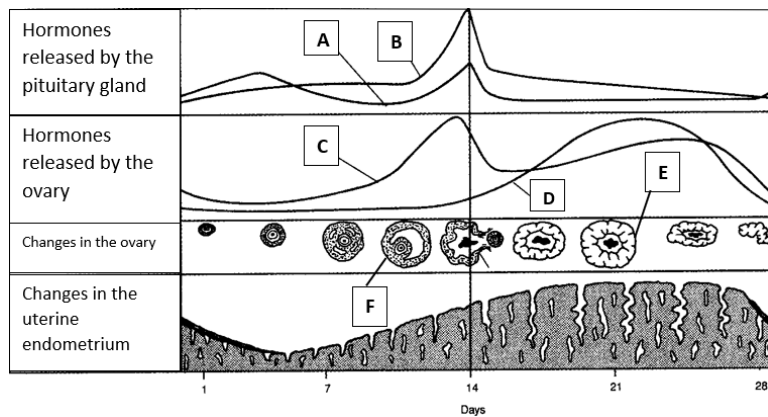

- (i) The alphabet 'A' represents \_\_\_\_\_ hormone:
- Oestrogen
  - Progesterone
  - FSH
  - LH
- (ii) The alphabet 'D' represents \_\_\_\_\_ hormone:
- Progesterone
  - Oestrogen
  - LH
  - FSH
- (iii) The structure marked 'E' is \_\_\_\_:
- Corpus luteum
  - Secondary follicle
  - Graafian follicle
  - Corpus albicans
- (iv) Ovulation occurs on day \_\_\_\_\_ of a typical menstrual cycle:
- 12
  - 14
  - 22
  - 28
- (v) Menstrual cycle operates in \_\_\_\_\_
- All vertebrates
  - All mammals
  - Only primates
  - Only apes

### Question 47

The pedigree chart given below represents the pattern of inheritance of haemophilia in a family. Study it carefully and answer the following questions:

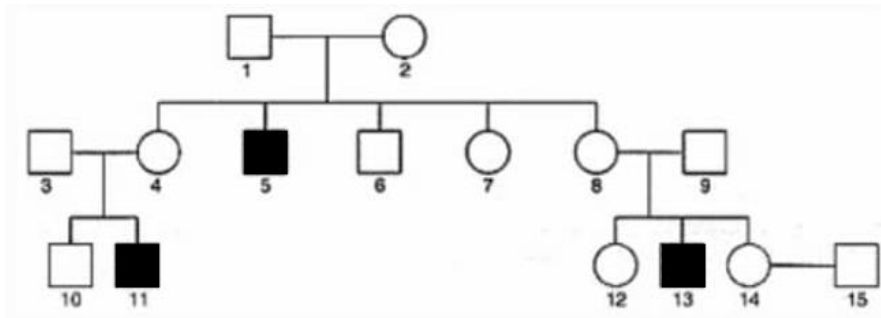

- (i) Identify the correct statement with respect to member '4':
- (a) He is a carrier male
  - (b) She is a carrier female
  - (c) He is haemophilic
  - (d) She is a homozygous female
- (ii) The possible genotype of member '5' is:
- (a)  $X^H X^H$
  - (b)  $X^H Y$
  - (c)  $X^h Y$
  - (d) None of these
- (iii) The possible genotype(s) of member '6' is/are:
- (a)  $X^H X^H$ ,  $X^H X^h$
  - (b)  $X^H Y$
  - (c)  $X^h X^h$
  - (d) None of these
- (iv) Haemophilia is a/an \_\_\_\_ trait:
- (a) Dominant
  - (b) Autosomal
  - (c) X-linked
- (v) Y-linked
- Assuming that member '14' is heterozygous for haemophilia, the probability of the son of this couple to be haemophilic is:
- (a) 25%
  - (b) 50%
  - (c) 75%
  - (d) 100%

### Question 48

The diagram of the organs of female reproductive system is given below. Study it carefully and answer the questions that follow:

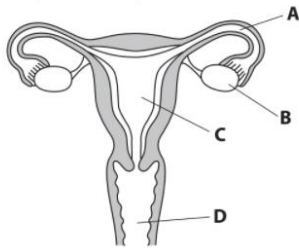

- (i) The place where fertilisation takes place is:
- (a) A
  - (b) B
  - (c) C
  - (d) D
- (ii) The place where the embryo is implanted:
- (a) A
  - (b) B
  - (c) C
  - (d) D
- (iii) The ovum is released by:
- (a) A
  - (b) B
  - (c) C
  - (d) D
- (iv) The hormone testosterone is released by:
- (a) A
  - (b) B
  - (c) C
  - (d) None of these
- (v) The \_\_\_\_ layer of the organ 'C' undergoes a cyclic change every month:
- (a) Outermost
  - (b) Innermost
  - (c) Middle
  - (d) Both 'b' and 'c'

### Question 49

Read the passage given below, and answer the questions that follow:

The cotton bollworm is considered a major pest, all over the world. Due to its destructive feeding nature and continuous consumption of the same chemicals, it evolved resistant against many insecticides. To overcome this problem, scientists introduced a virus which selectively infects and kills the bollworm.

- (i) The virus used in this process was:
- (a) Baculovirus
  - (b) Tobacco mosaic virus
  - (c) Bacteriophage
  - (d) All of these
- (ii) In scientific terms, this method of pest control is an example of:
- (a) Bioremediation
  - (b) Chemical control
  - (c) Biological control
  - (d) All the above
- (iii) The advantage of this process is that it helps in:
- (a) Controlling pollution
  - (b) Evolution of new chemicals
  - (c) Improving the quality of cotton
  - (d) None of these
- (iv) The virus used in this process can also be used to control some mosquito-borne diseases like:
- (a) Malaria
  - (b) Filaria
  - (c) Dengue
  - (d) None of these
- (v) From the statements given below, select the correct statement with respect to this process:
- (a) The viruses are specific to insect host species
  - (b) The viruses are not specific to individual insect host species
  - (c) The same virus can be used to control corn-borer also
  - (d) The insect host never develops resistance against the virus

### Question 50

Some students wanted to investigate the pattern of inheritance of flower colour in snapdragon. They selected some plants which were homozygous for red flowers and some other plants which were homozygous for white flowers. These plants were labelled as Parental Plants (P<sub>1</sub>). These plants (red-flowered and white-flowered), were cross-pollinated. The seeds obtained from these plants were planted in a separate field. These seeds germinated to produce the plants which were labelled as the plants of F<sub>1</sub>-generation.

Based on the above experiment, answer the following questions:

- (i) Select the statement which correctly predicts the phenotype of the plants of F<sub>1</sub> generation.
- (a) All the plants will bear red flowers
  - (b) All the plants will bear white flowers
  - (c) 50% plants will bear red flowers and 50% will bear white flowers
  - (d) 100% plants will bear pink flowers.

- (ii) If the plants of F1-generation are allowed to self-pollinate, then in F2-generation
- (a) All of the resulting plants will have pink flowers.
  - (b) 75% plants will have red flowers and the remaining 25% plants will have white flowers.
  - (c) 25% plants will have red flowers, 25% plants will have pink flowers and 25% will have white flowers.
  - (d) 25% plants will have red flowers and the remaining 75% plants will have white flowers.
- (iii) The genotypic ratio of the plants of F2-generation will be:
- (a) 1: 2: 3
  - (b) 9: 3: 3: 1
  - (c) 1: 2: 1
  - (d) 3:1
- (iv) This type of inheritance can be described as:
- (a) Polygenic inheritance
  - (b) Incomplete dominance
  - (c) Co-dominance
  - (d) Pleiotropism
- (v) The biological name of snapdragon is:
- (a) *Antirrhinum majus*
  - (b) *Pisum sativum*
  - (c) *Lathyrus odoratus*
  - (d) *Rhizobium leguminosarum*