



GOVERNMENT OF TAMIL NADU

HIGHER SECONDARY SECOND YEAR

PHYSICS

VOLUME - II

A publication under Free Textbook Programme of Government of Tamil Nadu

Department of School Education

Untouchability is Inhuman and a Crime

Government of Tamil Nadu

First Edition - 2019
(Published Under New Syllabus)

NOT FOR SALE

Content Creation



State Council of Educational
Research and Training

© SCERT 2019

Printing & Publishing



Tamil Nadu Textbook and Educational
Services Corporation

www.textbooksonline.tn.nic.in

CONTENTS

PHYSICS

UNIT 6	Optics	01
UNIT 7	Dual Nature of Radiation and Matter	105
UNIT 8	Atomic and Nuclear physics	138
UNIT 9	Semiconductor Electronics	192
UNIT 10	Communication Systems	238
UNIT 11	Recent Developments in Physics	256
	Glossary	288



E-book



Assessment



DIGI links



Let's use the QR code in the text books!

- Download DIKSHA app from the Google Play Store.
- Tap the QR code icon to scan QR codes in the textbook.
- Point the device and focus on the QR code.
- On successful scan, content linked to the QR code gets listed.

Note: For ICT corner, Digi Links QR codes use any other QR scanner.

HOW TO USE THE BOOK

Scope of Physics

- Awareness on higher learning - courses, institutions and required competitive exams
- Financial assistance possible to help students to climb academic ladder
- Gender initiatives by the Government of India.

Learning Objectives:

- Overview of the unit
- Gives clarity on the goals and objective of the topics



Example problems

- Additional facts related to the topics covered to facilitate curiosity driven learning

- To ensure understanding, problems/illustrations are given at every stage before advancing to next level



- Visual representation of concepts with illustrations
- Videos, animations, and tutorials



ICT

- To harness the digital skills to class room learning and experimenting

Summary

- Recap of salient points of the lesson

Concept Map

- Schematic outline of salient learning of the unit

Evaluation

- Evaluate students' understanding and get them acquainted with the application of physical concepts to numerical and conceptual questions

Books for Reference

- List of relevant books for further reading

Solved examples

- Solutions to exercise problems are accessible here. In addition, a few solved examples are given to facilitate students to apply the concepts learnt.

Competitive Exam corner

- Model Questions - To motivate students aspiring to take up competitive examinations such as NEET, JEE, Physics Olympiad, JIPMER etc

Glossary

- Scientific terms frequently used with their Tamil equivalents

Content Focus

- Covers ray and wave optics extensively, salient concepts in dual nature of radiation and matter, atomic and nuclear physics. Topics in semiconductors and communication are optimised. An exclusive unit on 'Recent developments in physics' highlights that physics is the basic building block for sciences, engineering, technology and medicine. With this, students are motivated to pursue higher education confidently.

Back Wrapper

Richard Philip Feynman, (1918–1988) a theoretical physicist who received noble prize in physics in 1965 for his contributions to the development of quantum electrodynamics. He is the first person to discuss the possibility of manipulation of atoms that seeded nanotechnology. His lectures on various topics in physics are very popular among physicists.

Illustration of Gravitational waves from two merging black holes.

Front Wrapper

*Actual photograph of a super massive black hole M87**

Scope of Physics - Higher Education



Entrance Examinations After +2

- Physics Olympiad Exam
- NEET-National Eligibility cum Entrance Test
- IIT JEE-Joint Entrance Examination (Mains & Advanced)
- NEST- National Entrance Screening Test
- KVPY-Kishore Vaigyanik Protsahan Yojana
- JEE Mains Paper II for B.Arch
- AIIMS - All Indian Institute of Medical Science's Examination
- Chennai Mathematical Institute Entrance Examination
- BITSAT- Birla Institute of Science And Technology Admission Test
- AIEEE – All India Engineering Entrance Exam
- CUCET – Central Universities Common Entrance Test
- JIPMER - Jawaharlal Institute of Postgraduate Medical Education & Research
- CLAT – Common Law Admission Test
- HSEE- Humanities and Social Sciences Entrance Examination
- APVT -All India Pre-Veterinary Test
- NDA – National Defence Academy Examination

After Graduation

- JAM- Joint Admission Test
- JEST – Joint Entrance Screening Test
- GATE- Graduate Aptitude Test in Engineering
- CAT – Common Admission Test (for MBA)
- Exams conducted by Respective Universities

After Post Graduation

- CSIR NET - National Eligibility Test for JRF and Lectureship

After Completing +2

- Integrated M.Sc. Physics
- Central Universities through CUCET
- Central Research Institutes like IISER using KVPY, JEE Advanced
- ◆ IISER aptitude test
- ◆ Top 1% students in State board are eligible for IISER Aptitude Test
- Admission in NISER through NEST
- B.Sc Photonics
- B.Sc Hons. in Mathematics and Physics in CMI
- B.Sc Hons. in Mathematics and Computer Science in CMI
- Five-Year Dual degree In IIST (B.Tech + Master of Science)
- Master of Science (Astronomy and Astrophysics, Solid State Physics)

Note

- Students admitted to IISc, IIT's, NIT's
- IISER's, IIST, will get a Scholarship equivalent to INSPIRE
- Assured placement in ISRO and other divisions for the students of IIST
- Institutes and their ranking can be found in www.nirfindia.org

After B.Sc Physics

- M.Sc Physics in IIT's and NIT's through JAM
- Integrated Ph.D in IISER's and IISc through JAM and JEST
- M.Sc Physics in Central Universities through CUCET
- M.Sc in Energy Physics, Applied Physics in IIT's through JAM
- Integrated Ph.D in IMSc, TIFR, JNCASR through JEST score
- Integrated Ph.D in TIFR through JEST and TIFR exam
- M.Sc Photonics, Reactor physics, Nuclear Engineering ,
- M.Sc Medical Physics
- M.Sc Biophysics
- Research Institutes abroad like CERN, NASA, LIGO offer Summer internship programmes for motivated Indian students pursuing Undergraduate course in physics
- Indian Academy of Science & various other research institutes offer paid Summer Internship for science students to get an hands on experience in research.

Opportunities after B.Sc. Physics

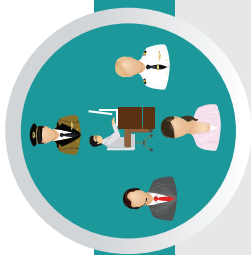

Jobs in Government Sector

- Scientific Officer and Scientific Assistant Jobs
- CSIR Labs
- DRDO – Defence Research and Development Organisation
- DAE -Department of Atomic Energy
- DoS - Department of Science
- IMD- Indian Meteorological Department
- ONGC -Oil and Natural Gas Corporation
- ATC – Air Traffic Controller
- Teaching faculty in schools and colleges through SET, NET,TET
- Scientist post in various research institutes in India

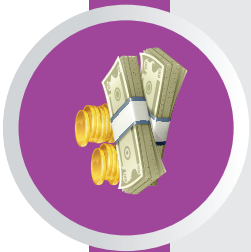

Scholarships

- INSPIRE Scholarship - Scholarship for Higher Education (SHE) - 80000 per annum, for B.Sc/B.S/Int M.Sc/Int M.S
- Eligibility Criteria:- Top 1% students in their +2 board exam
- Top 10000 rank holders in JEE or NEET
- Students studying at IISER, IISER, Department of Atomic Energy Centre for Basic Science
- NTSE, KVPY, JBNS TS Scholars
- International Olympiad Medalists
- Indra Gandhi Scholarship for single girl child for full time regular Master's Degree
- Post Graduate Merit Scholarship for University rank holders in UG level
- Mathematics Training and Talent Search (MTTS) Programme
- Eligibility Criteria:- Students who studied Maths at UG or PG level
- Dr. K S Krishnan Research Associateship (KSKRA)
- Eligibility Criteria:- Students who possess Master's Degree or Ph.D in science or engineering
- IGCAR JRF
- Eligibility Criteria:- Passing JEST, GATE, NET Exams
- Promotion of Science Education (POSE) Scholarship Scheme
- Dhirubhai Ambani Scholarship Programme
- Foundation for Academic Excellence and Access Scholarship (FAEA)
- Central Sector Scheme of National Fellowship and Scholarship for Higher Education of ST students
- Pre - Matric and Post - Matric Scholarship for students belonging to minority communities to pursue their School and Collegiate education by the Ministry of Minority affairs, Government of India.
- Pre Matric and Post Matric Scholarship for students with Disabilities to pursue their School and Collegiate Education by the Department of Empowerment of Persons with Disabilities, Government of India.
- Maulana Azad scholarship for minorities.

Institutes in india to pursue research in physics

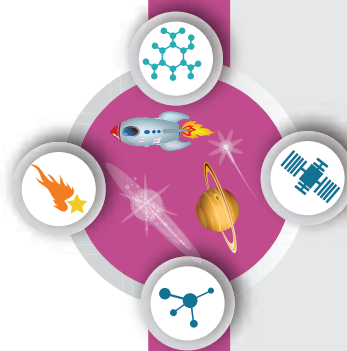

Research Areas

General Relativity and Cosmology
 Astronomy and Astrophysics
 Quantum Optics and Information theory
 Plasma physics
 Meteorology and Atmospheric science
 String Theory, Quantum Gravity
 Optics and Photonics
 Condensed Matter Theory, Material Science and Spintronics
 Cryptography
 Mathematical Physics, Statistical Physics
 Crystal Growth and Crystallography
 Atomic and Molecular Physics
 Biophysics, Medical Physics
 Nuclear and High energy Particle Physics
 Energy and Environmental Studies
 Geophysics
 Quantum Biology and Quantum Thermodynamics and Cymatics

Famous Research Institutes for Physics in India

Name of the Institution	Website
Institute of Mathematical Sciences, Chennai (IMSc)	www.imsc.res.in
Saha Institute of Nuclear Physics, Kolkata	www.saha.ac.in
International Centre for Theoretical Sciences, Bangalore	www.icts.res.in
Harish chandra Research Institute, Allahabad	www.hri.res.in
Aryabhata Research Institute of Observational Sciences, Nainital	www.aries.res.in
Jawaharlal Nehru Centre for Advanced Scientific Research (JNCASR)	www.jncasr.ac.in
Institute of Physics (IOP), Bhubaneswar	www.iopb.res.in
Indian Association for the Cultivation of Sciences (IACS), Kolkata	www.iacs.res.in
Vikram Sarabhai Space Centre (VSSC), Thiruvananthapuram	www.vssc.gov.in
National Physical Laboratory (NPL), Delhi	www.nplindia.in
National Institute of Science Education and Research (NISER), Bhubaneswar	www.niser.ac.in
Indian Institute of Science (IISc), Bangalore	www.iisc.ac.in
Raman Research Institute (RRI), Bangalore	www.rri.res.in
Tata Institute of Fundamental Research (TIFR), Mumbai	www.tifr.res.in
Bhabha Atomic Research Centre (BARC), Mumbai	www.barc.gov.in
Indira Gandhi Centre for Atomic Research (IGCAR), Kalpakkam	www.igcar.gov.in
Inter University Centre for Astronomy and Astrophysics (IUCAA), Pune	www.iucaa.in
Indian Institute of Space Science and Technology (IIST), Trivandrum	www.iist.ac.in
Institute of Plasma Research (IPR), Gujarat	www.ipr.res.in
Physical Research Laboratory (PRL), Ahmedabad	www.prl.res.in
Inter-University Accelerator Center (IUAC), Delhi	www.iuac.res.in
Indian Institute of Astrophysics (IIA), Bangalore	www.iiap.res.in
Chennai Mathematical Institute (CMI), Chennai	www.cmi.ac.in
Liquid Propulsion Systems Centre	www.lpsc.gov.in
S.N.Bose Centre for Basic Sciences	www.bose.res.in
CSIR National laboratories	
Indian Institute of Technology (IIT) in various places	
IISER's in various places	
National Institute of Technology (NIT) in various places	
Indian Institute of Information Technology (IIITs) at various places	
Central and State Universities	

Gender Initiatives by the Government of India

Women Scientist Scheme by the Department of Science and Technology (DST)

- Under this scheme, women scientists are being encouraged to pursue research in frontier areas of science and engineering, on problems of societal relevance and to take up S&T-based internship followed by self-employment. Following three categories of fellowships, with research grants, are available for Indian citizen:

- Women Scientist Scheme-A(WOS-A): Research in Basic/Applied Science
- Women Scientist Scheme-B (WOS-B): S&T interventions for Societal Benefit
- Women Scientist Scheme-C (WOS-C): Internship in Intellectual Property Rights (IPRs) for the Self-Employment

Eligibility:

The scheme is meant to encourage women in S&T domain, preferably those having a break in career and not having regular employment, to explore possibility of re-entry into the profession.

Qualifications:

- Minimum Post Graduate degree, equivalent to M.Sc. in Basic or Applied Sciences or B.Tech. or MBBS or other equivalent professional qualifications
- M.Phil/M.Tech/M.Pharm/M.VSc or equivalent qualifications
- Ph.D. in Basic or Applied Sciences

- <http://www.dst.gov.in/scientific-programmes/scientific-engineering-research/women-scientists-programs>

Global STEM (Science, Technology, Engineering and Mathematics) Scholarships for Indian Women in Science

- A list of some STEM scholarships offered to Indian Women if they would like to pursue their higher education abroad.

- Society of Women Engineers (SWE) Scholarship
- The Google Anita Borg Memorial Scholarship Program
- Women In Aviation International Scholarships
- Amelia Earhart Fellowship by Zonta International
- The Graduate Women In Science (GWIS) National Fellowships Program

- <https://feminisminindia.com/2017/06/14/global-stem-scholarships/>



KIRAN (Knowledge Involvement in Research Advancement through Nurturing) Scheme of DST

- <https://www.ugc.ac.in/pdfw/>

UNIT 6

OPTICS

An age is called dark, not because the light fails to shine, but because people refuse to see.

— James Albert Michener

LEARNING OBJECTIVES

In this unit, the students are exposed to,

- The two aspects of treating light as a ray and a wave.
- The behaviour and propagation of light.
- The concepts related to mirrors, lenses, prisms etc.
- The different optical instruments like microscope, telescope etc.
- The terms like magnification and resolving power etc.
- The various phenomena that support the wave nature of light.



6.1

INTRODUCTION

Light is mystical. Yet, its behaviour is so fascinating. It is difficult to comprehend light to a single entity. In this unit, we learn it in two different scientific aspects called ray optics and wave optics. Ray optics deals with light that is represented as a ray travelling in straight lines. The geometrical constructs get the permanence to understand the various characteristics of light. In wave optics, we study about the phenomenon associated with the propagation of light as a wave. First, let us learn the ray optics followed by the wave optics.

6.1.1 Ray optics

Light travels in a straight line in a medium. Light may deviate in its path only when it encounters another medium or an obstacle.

A ray of light gives information about only the direction of light. It does not give information about the other characteristics of light like intensity and colour. However, a ray is a sensible representation of light in ray optics. The path of the light is called a ray of light and a bundle of such rays is called a beam of light. In this chapter, we can explain the phenomena of reflection, refraction, dispersion and scattering of light, using the ray depiction of light.

6.1.2 Reflection

The bouncing back of light into the same medium when it encounters a reflecting surface is called *reflection of light*. Polished surfaces can reflect light. Mirrors which are silver coated at their back can reflect almost 90% of the light falling on them. The angle of incidence i and the angle

of reflection r are measured with respect to the normal drawn to the surface at the point of incidence of light. **According to law of reflection,**

- (a) The incident ray, reflected ray and normal to the reflecting surface all are coplanar (ie. lie in the same plane).
- (b) The angle of incidence i is equal to the angle of reflection r .

$$i = r \quad (6.1)$$

The law of reflection is shown in Figure 6.1.

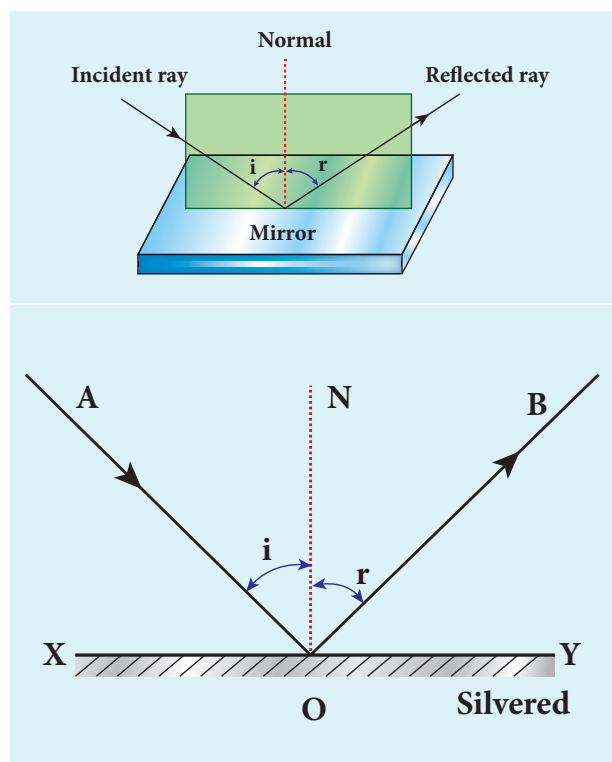

Figure 6.1 Reflection of light

The law of reflection is valid at each point for any reflecting surface whether the surface is plane or curved. If the reflecting surface is flat, then incident parallel rays after reflection come out parallel as per the law of reflection. If the reflecting surface is irregular, then the incident parallel rays after reflection come out irregular (not parallel) rays. Still law of reflection is valid at every point of incidence as shown in Figure 6.2.

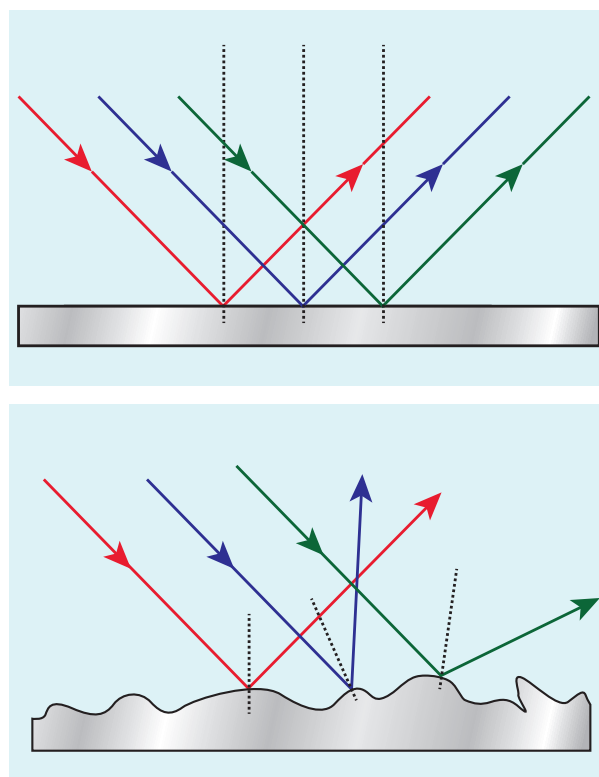

Figure 6.2 Regular and irregular reflections

6.1.3 Angle of deviation due to reflection

The angle between the incident and deviated light ray is called *angle of deviation of the light ray*. In reflection, it is calculated by a simple geometry as shown in Figure 6.3(a). The incident light is AO. The reflected light is OB. The un-deviated light is OC which is the continuation of the incident light. The angle between OB and OC is the angle of deviation d . From the geometry, it is written as, $d = 180 - (i+r)$. As, $i = r$ in reflection, we can write angle of deviation in reflection at plane surface as,

$$d = 180 - 2i \quad (6.2)$$

The angle of deviation can also be measured in terms of the glancing angle α which is measured between the incident ray AO and the reflecting plane surface XY as

shown in Figure 6.3(b). By geometry, the angles $\angle AOX = \alpha$, $\angle BOY = \alpha$ and $\angle YOC = \alpha$ (are all same). The angle of deviation (d) is the angle $\angle BOC$. Therefore,

$$d = 2\alpha \quad (6.3)$$

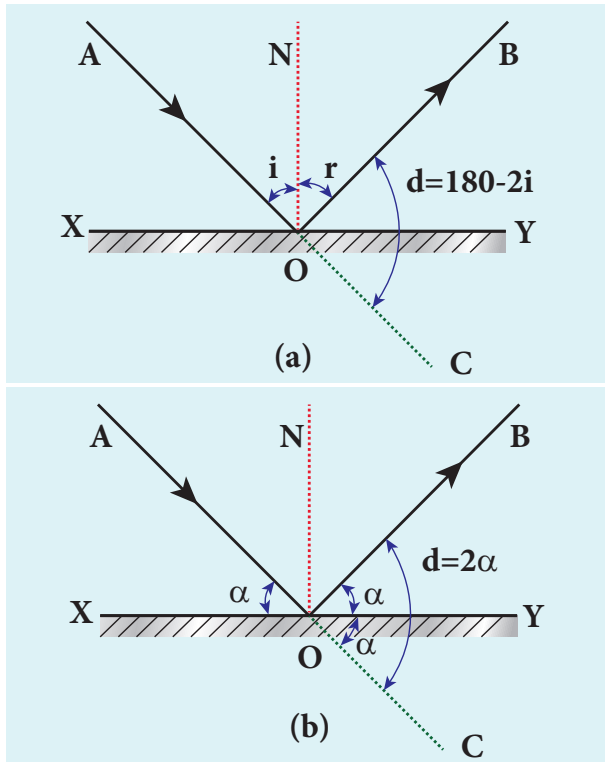

Figure 6.3 Angle of deviation due to reflection

EXAMPLE 6.1

Prove that when a reflecting surface of light is tilted by an angle θ , the reflected light will be tilted by an angle 2θ .

Solution

For the reflecting surface AB , the incident ray IO and the reflected ray OR_1 subtend angle i with the normal N as angle of incidence is equal to angle of reflection as shown in figure. When the surface AB is tilted to $A'B'$ by an angle θ , the normal N' is also tilted by the same angle θ . Remember the position of incident ray IO remains unaltered. But,

in the tilted system the angle of incidence is now $i + \theta$ and the angle of reflection is also $i + \theta$. Now, OR_2 is the reflected ray. The angle between OR_2 and OR_1 is,

$$\angle R_1OR_2 = \angle N'OR_2 - \angle NOR_1$$

$$(i + \theta) - (i - \theta) = 2\theta.$$

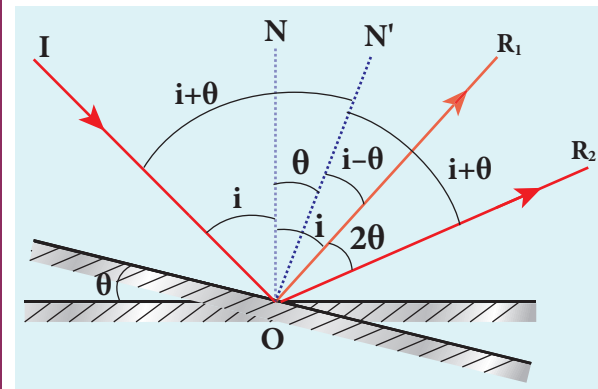

6.1.4 Image formation in plane mirror

Let us consider a point object A is placed in front of a plane mirror and the point of incidence is O on the mirror as shown in the Figure. 6.4. A light ray AO from the point object is incident on the mirror and it is reflected along OB . The normal is ON .

The angle of incidence $\angle AON =$ angle of reflection $\angle BON$

Another ray AD incident normally on the mirror at D is reflected back along DA . When BO and AD are extended backwards, they meet at a point A' . Thus, the rays appear to come from a point A' which is behind the plane mirror. The object and its image in a plane mirror are at equal perpendicular distances from the plane mirror which can be shown by the following explanation.

In Figure 6.4, Angle $\angle AON =$ angle $\angle DAO$ [Since they are alternate angles]

Angle $\angle BON =$ angle $\angle OA'D$ [Since they are corresponding angles]

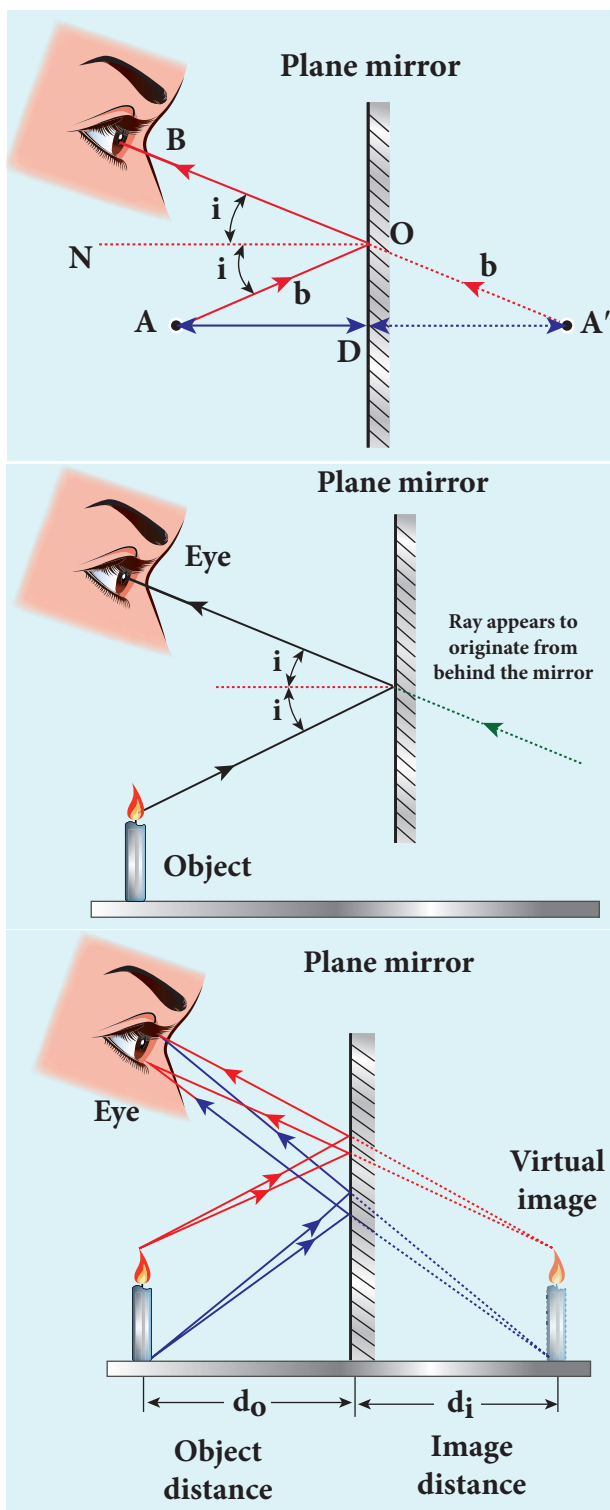

Figure 6.4 Formation of image in plane mirror

Hence, it follows that angle, $\angle DAO = \angle OA'D$

The triangles $\triangle ODA$ and $\triangle ODA'$ are congruent

$$\therefore AD = A'D$$

This shows that the image distance inside the plane mirror is equal to the object distance in front of the plane mirror.

6.1.5 Characteristics of the image formed by plane mirror

- (i) The image formed by a plane mirror is virtual, erect, and laterally inverted.
- (ii) The size of the image is equal to the size of the object.
- (iii) The image distance far behind the mirror is equal to the object distance in front of it.
- (iv) If an object is placed between two plane mirrors inclined at an angle θ , then the number of images n formed is as,

☞ If $\left(\frac{360}{\theta}\right)$ is even then, $n = \left(\frac{360}{\theta} - 1\right)$
for objects placed symmetrically or unsymmetrically,

☞ If $\left(\frac{360}{\theta}\right)$ is odd then, $n = \left(\frac{360}{\theta} - 1\right)$
for objects placed symmetrically,

☞ If $\left(\frac{360}{\theta}\right)$ is odd then, $n = \left(\frac{360}{\theta}\right)$
for objects placed unsymmetrically.

6.1.6 Real and virtual images by a plane mirror

When a real object is placed at a point O in front of a plane mirror it produces divergent rays in all directions as shown in Figure 6.5(a). After reflection from the plane mirror they appear to come out from a point I behind the mirror. This image cannot be formed on a screen as the image is behind the mirror. **This type of image which cannot be formed on the screen but can only be seen with the eyes is called *virtual image*.**

On the other hand, if convergent rays are incident on a plane mirror, the rays after

reflection pass through a point I in front of the mirror and form an image as shown in Figure 6.5(b). This image can be formed on a screen as the image is in front of the mirror. **This type of image which can be formed on a screen and can also be seen with the eyes is called *real image*.**

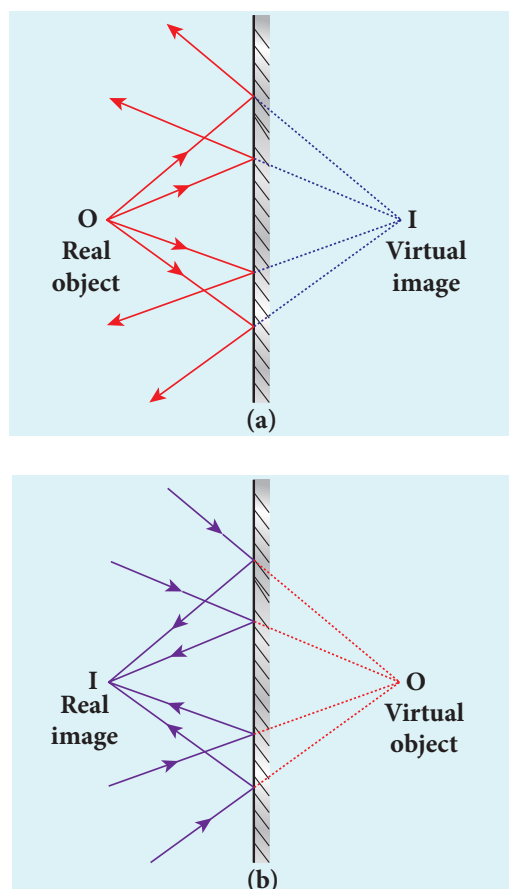

Figure 6.5 Real and virtual images by plane mirror

Note It is generally known that a plane mirror can only form a virtual image. But, now we have understood that a plane mirror can form a real image when converging rays fall on it.

The above discussion is consolidated in Table 6.1. These concepts will be very much useful in deciding about the nature of object and image in ray optics.

Table 6.1 Conditions for nature of objects and images

Nature of object/image	Condition
Real Image	Rays actually converge at the image
Virtual Image	Rays appear to diverge from the image
Real Object	Rays actually diverge from the object
Virtual Object	Rays appear to converge at the object

EXAMPLE 6.2

What is the height of the mirror needed to see the image of a person fully on the mirror?

Solution

Let us assume a person of height h is standing in front of a vertical plane mirror. The person could see his/her head when light from the head falls on the mirror and gets reflected to the eyes. Same way, light from the feet falls on the mirror and gets reflected to the eyes.

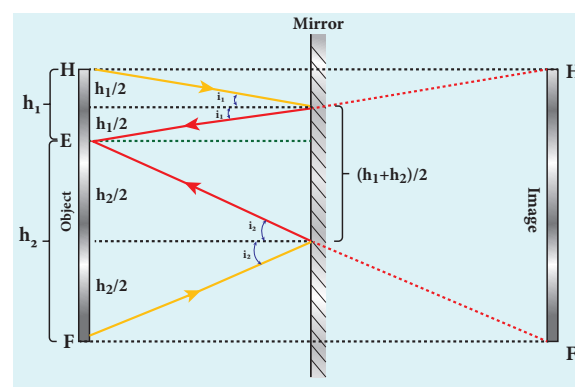

If the distance between his head H and eye E is h_1 and distance between his feet F and eye E is h_2 . The person's total height h is, $h = h_1 + h_2$

By the law of reflection, the angle of incidence and angle of reflection are the same in the two extreme reflections. The normals are now the bisectors of angles between incident and reflected rays in the two reflections. By geometry, the height of the mirror needed is only half of the height

$$\text{of the person. } \frac{h_1 + h_2}{2} = \frac{h}{2}$$

Does the height depend on the distance between the person and the mirror?

6.2 SPHERICAL MIRRORS

We shall now study about the reflections that take place in spherical surfaces.

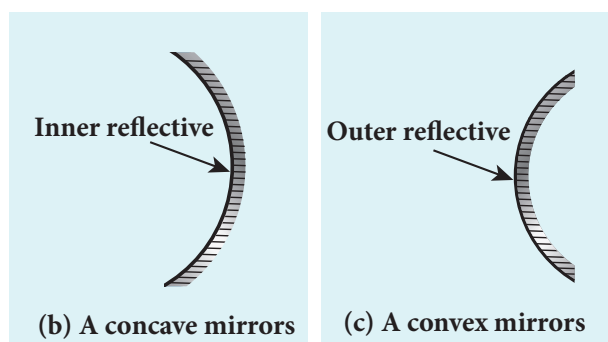
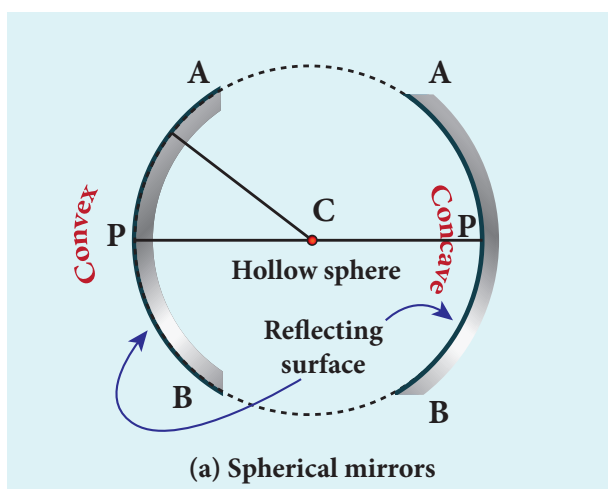

Figure 6.6 Spherical mirrors

A spherical surface is a part cut from a hollow sphere. Spherical mirrors are generally constructed from glass. One

surface of the glass is silvered. The reflection takes place at the other polished surface. **If the reflection takes place at the convex surface, it is called a convex mirror and if the reflection takes place at the concave surface, it is called a concave mirror.** These are shown in Figure 6.6.

We shall now become familiar with some of the terminologies pertaining to spherical mirrors.

Centre of curvature: The centre of the sphere of which the mirror is a part is called the *centre of curvature* (C) of the mirror.

Radius of curvature: The radius of the sphere of which the spherical mirror is a part is called the *radius of curvature* (R) of the mirror.

Pole: The middle point on the spherical surface of the mirror (or) the geometrical center of the mirror is called *pole* (P) of the mirror.

Principal axis: The line joining the pole and the centre of curvature is called the *principal axis* of the mirror. The light ray travelling along the principal axis towards the mirror after reflection travels back along the same principal axis. It is also called optical axis

Focus (or) Focal point: Light rays travelling parallel and close to the principal axis when incident on a spherical mirror, converge at a point for concave mirror or appear to diverge from a point for convex mirror on the principal axis. This point is called the *focus* or *focal point* (F) of the mirror.

Focal length: The distance between the pole and the focus is called the *focal length* (f) of the mirror.

Focal plane: The plane through the focus and perpendicular to the principal axis is called the *focal plane* of the mirror.

All the above mentioned terms are shown in Figure 6.7 for both concave and convex mirrors.

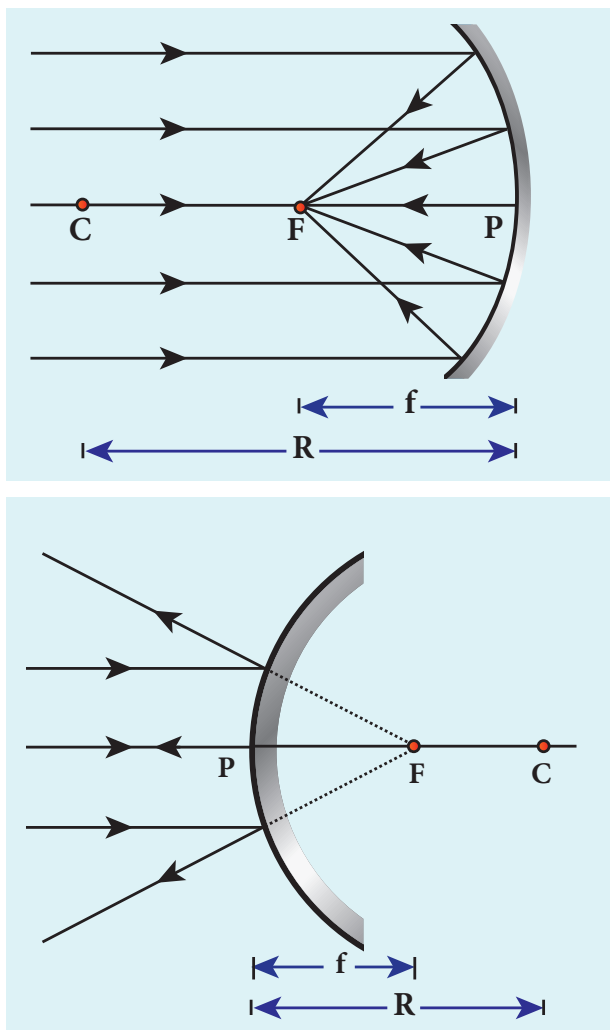

Figure 6.7 Focal length of concave and convex mirrors

6.2.1 Paraxial Rays and Marginal Rays

The rays travelling very close to the principal axis and make small angles with it are called *paraxial rays*. The paraxial rays fall on the mirror very close to the pole of the mirror. On the other hand, the rays travelling far away from the principal axis and fall on the mirror far away from the pole are called as *marginal rays*. These two rays behave differently (get focused at different points) as shown in Figure 6.8. In this chapter, we shall restrict our studies only to paraxial rays. As the angles made by the paraxial rays are very small, this helps

us to make some approximations with the angles in ray optics.

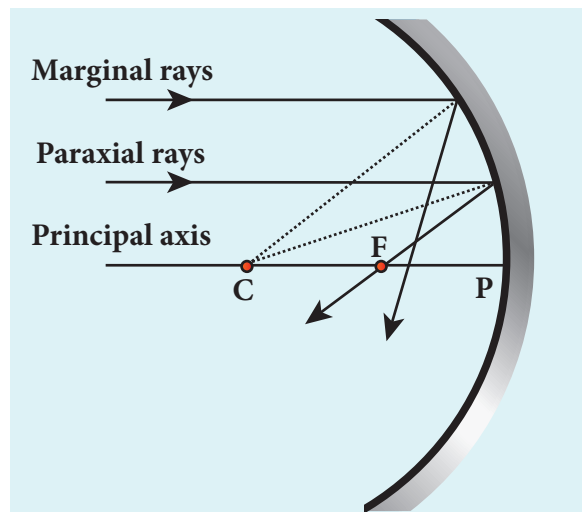

Figure 6.8 Paraxial and marginal rays

6.2.2 Relation between f and R

Let C be the centre of curvature of the mirror. Consider a light ray parallel to the principal axis is incident on the mirror at M and passes through the principal focus F after reflection. The geometry of reflection of the incident ray is shown in Figure 6.9(a). The line CM is the normal to the mirror at M . Let i be the angle of incidence and the same will be the angle of reflection.

If MP is the perpendicular from M on the principal axis, then from the geometry,

$$\text{The angles } \angle MCP = i \text{ and } \angle MFP = 2i$$

From right angle triangles $\triangle MCP$ and $\triangle MFP$,

$$\tan i = \frac{PM}{PC} \text{ and } \tan 2i = \frac{PM}{PF}$$

As the angles are small, $\tan i \approx i$,

$$i = \frac{PM}{PC} \text{ and } 2i = \frac{PM}{PF}$$

Simplifying further,

$$2 \frac{PM}{PC} = \frac{PM}{PF}; 2PF = PC$$

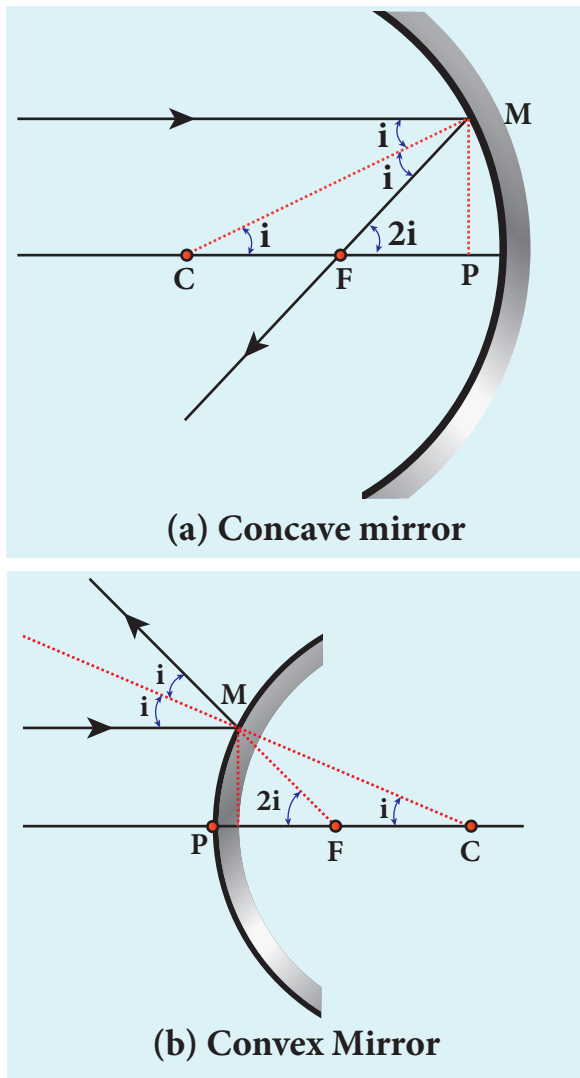

Figure 6.9 relation between R and f

PF is focal length f and PC is the radius of curvature R .

$$2f = R \quad (\text{or}) \quad f = \frac{R}{2} \quad (6.4)$$

Equation (6.4) is the relation between f and R . The construction is shown for convex mirror in figure 6.9(b)

6.2.3 Image formation in spherical mirrors

The image can be located by graphical construction. To locate the point of an image, a minimum of two rays must meet at that point. We can use at least any two of

the following rays to locate the image point as shown in Figure 6.10.

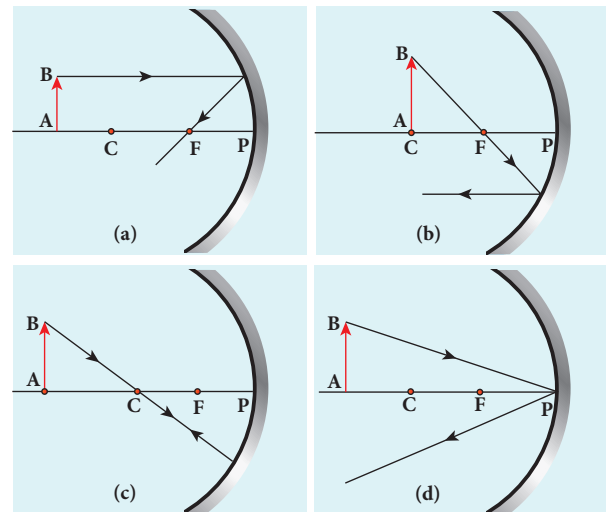

Figure 6.10 Image tracing

- (i) A ray parallel to the principal axis after reflection will pass through or appear to pass through the principal focus. (Figure 6.10(a))
- (ii) A ray passing through or appear to pass through the principal focus, after reflection will travel parallel to the principal axis. (Figure 6.10(b))
- (iii) A ray passing through the centre of curvature retraces its path after reflection as it is a case of normal incidence. (Figure 6.10(c))
- (iv) A ray falling on the pole will get reflected as per law of reflection keeping principal axis as the normal. (Figure 6.10(d))

6.2.4 Cartesian sign convention

While tracing the image, we would normally come across the object distance u , the image distance v , the object height h , the image height (h'), the focal length f and the radius of curvature R . A system of signs for these quantities must be followed so that the relations connecting them are consistent in all types of physical situations. We shall

follow the Cartesian sign convention which is now widely used as given below and also shown in Figure 6.11.

- (i) The Incident light is taken from left to right (i.e. object on the left of mirror).
- (ii) All the distances are measured from the pole of the mirror (pole is taken as origin).
- (iii) The distances measured to the right of pole along the principal axis are taken as positive.
- (iv) The distances measured to the left of pole along the principal axis are taken as negative.
- (v) Heights measured in the upward perpendicular direction to the principal axis are taken as positive.
- (vi) Heights measured in the downward perpendicular direction to the principal axis, are taken as negative.

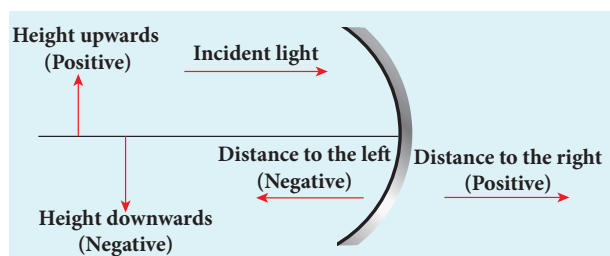

Figure 6.11 Cartesian sign convention

6.2.5 The mirror equation

The mirror equation establishes a relation among object distance u , image distance v and focal length f for a spherical mirror.

An object AB is considered on the principal axis of a concave mirror beyond the center of curvature C . The image formation is shown in the Figure 6.12. Let us consider three paraxial rays from point B on the object. The first paraxial ray BD travelling parallel to principal axis is incident on the concave mirror at D , close to the pole P . After reflection the ray passes through the focus F . The second paraxial ray BP incident

at the pole P is reflected along PB' . The third paraxial ray BC passing through centre of curvature C , falls normally on the mirror at E is reflected back along the same path. The three reflected rays intersect at the point B' . A perpendicular drawn as $A'B'$ to the principal axis is the real, inverted image of the object AB .

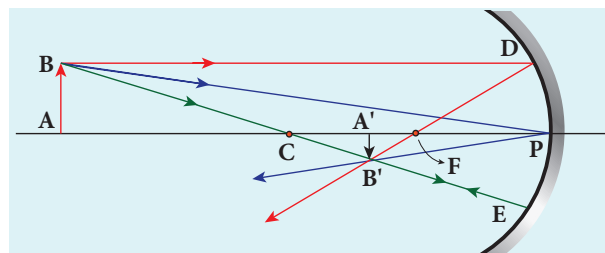

Figure 6.12 Mirror equation

As per law of reflection, the angle of incidence $\angle BPA$ is equal to the angle of reflection $\angle B'PA'$.

The triangles $\triangle BPA$ and $\triangle B'PA'$ are similar. Thus, from the rule of similar triangles,

$$\frac{A'B'}{AB} = \frac{PA'}{PA} \quad (6.5)$$

The other set of similar triangles are, $\triangle DPF$ and $\triangle B'A'F$. (PD is almost a straight vertical line)

$$\frac{A'B'}{PD} = \frac{A'F}{PF}$$

As, the distances $PD = AB$ the above equation becomes,

$$\frac{A'B'}{AB} = \frac{A'F}{PF} \quad (6.6)$$

From equations (6.5) and (6.6) we can write,

$$\frac{PA'}{PA} = \frac{A'F}{PF}$$

As, $A'F = PA' - PF$, the above equation becomes,

$$\frac{PA'}{PA} = \frac{PA' - PF}{PF} \quad (6.7)$$

We can apply the sign conventions for the various distances in the above equation.

$$PA = -u, \quad PA' = -v, \quad PF = -f$$

All the three distances are negative as per sign convention, because they are measured to the left of the pole. Now, the equation (6.7) becomes,

$$\frac{-v}{-u} = \frac{-v - (-f)}{-f}$$

On further simplification,

$$\frac{v}{u} = \frac{v-f}{f}; \quad \frac{v}{u} = \frac{v}{f} - 1$$

Dividing either side with v ,

$$\frac{1}{u} = \frac{1}{f} - \frac{1}{v}$$

After rearranging,

$$\frac{1}{v} + \frac{1}{u} = \frac{1}{f} \quad (6.8)$$

The above equation (6.8) is called **mirror equation**. Although this equation is derived for a special situation shown in Figure (6.12), it is also valid for all other situations with any spherical mirror. This is because proper sign convention is followed for u , v and f in equation (6.7).

6.2.6 Lateral magnification in spherical mirrors

The lateral or transverse magnification is defined as the ratio of the height of the image to the height of the object. The height of the object and image are measured perpendicular to the principal axis.

$$\text{magnification } (m) = \frac{\text{height of the image } (h')}{\text{height of the object } (h)}$$

$$m = \frac{h'}{h} \quad (6.9)$$



Identify the type of mirror used in each of the application shown above.

Applying proper sign conventions for equation (6.5),

$$\frac{A'B'}{AB} = \frac{PA'}{PA}$$

$$A'B' = -h, AB = h, PA' = -v, PA = -u$$

$$\frac{-h'}{h} = \frac{-v}{-u}$$

On simplifying we get,

$$m = \frac{h'}{h} = -\frac{v}{u} \quad (6.10)$$

Using mirror equation, we can further write the magnification as,

$$m = \frac{h'}{h} = \frac{f-v}{f} = \frac{f}{f-u} \quad (6.11)$$

Note

The students are advised to refresh themselves with the image tracing for the concave and convex mirrors for various predetermined positions of the object and the position of image, nature of image etc. studied in 9th standard (Science, Unit 6. Light).

EXAMPLE 6.3

An object is placed at a distance of 20.0 cm from a concave mirror of focal length 15.0 cm.

- (a) What distance from the mirror a screen should be placed to get a sharp image?
 (b) What is the nature of the image?

Solution

Given, $f = -15$ cm, $u = -20$ cm

(a) Mirror equation, $\frac{1}{v} + \frac{1}{u} = \frac{1}{f}$

Rewriting to find v , $\frac{1}{v} = \frac{1}{f} - \frac{1}{u}$

Substituting for f and u , $\frac{1}{v} = \frac{1}{-15} - \frac{1}{-20}$

$$\frac{1}{v} = \frac{(-20) - (-15)}{300} = \frac{-5}{300} = \frac{-1}{60}$$

$$v = -60.0 \text{ cm}$$

As the image is formed at 60.0 cm to the left of the concave mirror, the screen is to be placed at distance 60.0 cm to the left of the concave mirror.

(b) Magnification, $m = \frac{h'}{h} = -\frac{v}{u}$

$$m = \frac{h'}{h} = -\frac{(-60)}{(-20)} = -3$$

As the sign of magnification is negative, the image is inverted.

As the magnitude of magnification is 3, the image is enlarged three times.

As the image is formed to the left of the concave mirror, the image is real.

EXAMPLE 6.4

A thin rod of length $f/3$ is placed along the optical axis of a concave mirror of focal length f such that its image which is real and elongated just touches the rod. Calculate the longitudinal magnification.

Solution

$$\text{longitudinal magnification } (m) = \frac{\text{length of image } (l')}{\text{length of object } (l)}$$

Given: length of object, $l = \frac{f}{3}$

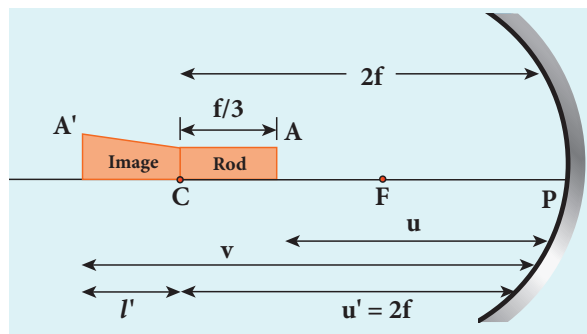

Let, l be the length of the image, then,

$$m = \frac{l'}{l} = \frac{l'}{f/3} \quad (\text{or}) \quad l = \frac{mf}{3}$$

Image of one end coincides with the object. Thus, the coinciding end must be at center of curvature.

Hence, $u' = R = 2f$

$$u' = u + \frac{f}{3}$$

$$u = u' - \frac{f}{3} = 2f - \frac{f}{3} = \frac{5f}{3}$$

$$v = u + \frac{f}{3} + \frac{mf}{3} = \frac{5f}{3} + \frac{f}{3} + \frac{mf}{3} = \frac{f(6+m)}{3}$$

Mirror equation, $\frac{1}{v} + \frac{1}{u} = \frac{1}{f}$

$$\frac{1}{-\left(\frac{f(6+m)}{3}\right)} + \frac{1}{-\left(\frac{5f}{3}\right)} = \frac{1}{-f}$$

After simplifying,

$$\frac{3}{f(6+m)} + \frac{3}{5f} = \frac{1}{f}; \frac{3}{(6+m)} = \frac{2}{5}$$

$$6+m = \frac{15}{2}; m = \frac{15}{2} - 6$$

$$m = \frac{3}{2} = 1.5$$

6.3

SPEED OF LIGHT

Light travels with the highest speed in vacuum. The speed of light in vacuum is denoted as c and its value is, $c = 3 \times 10^8 \text{ m s}^{-1}$. It is a very high value. Several attempts were made by scientists to determine the speed of light. The earliest attempt was made by a French scientist Hippolyte Fizeau (1819–1896). That paved way for the other scientists too to determine the speed of light.

6.3.1 Fizeau's method to determine speed of light

Apparatus: The apparatus used by Fizeau for determining speed of light in air is shown in Figure 6.13. The light from the source S was first allowed to fall on a partially silvered glass plate G kept at an angle of 45° to the incident light from the source. The light then was allowed to pass through a rotating toothed-wheel with N teeth and N cuts of equal widths whose speed of rotation could be varied through an external mechanism (not shown in the Figure). The light passing through one cut

in the wheel will get reflected by a mirror M kept at a long distance d , about 8 km from the toothed wheel. If the toothed wheel was not rotating, the reflected light from the mirror would again pass through the same cut and reach the eyes of the observer through the partially silvered glass plate.

Working: The angular speed of rotation of the toothed wheel was increased from zero to a value ω until light passing through one cut would completely be blocked by the adjacent tooth. This is ensured by the disappearance of light while looking through the partially silvered glass plate.

Expression for speed of light: The speed of light in air v is equal to the ratio of the distance the light travelled from the toothed wheel to the mirror and back $2d$ to the time taken t .

$$v = \frac{2d}{t} \quad (6.12)$$

The distance d is a known value from the arrangement. The time taken t for the light to travel the distance to and fro is calculated from the angular speed ω of the toothed wheel.

The angular speed ω of the toothed wheel when the light disappeared for the first time is,

$$\omega = \frac{\theta}{t} \quad (6.13)$$

Here, θ is the angle between the tooth and the slot which is rotated by the toothed wheel within that time t .

$$\theta = \frac{\text{total angle of the circle in radian}}{\text{number of teeth} + \text{number of cuts}}$$

$$\theta = \frac{2\pi}{2N} = \frac{\pi}{N}$$

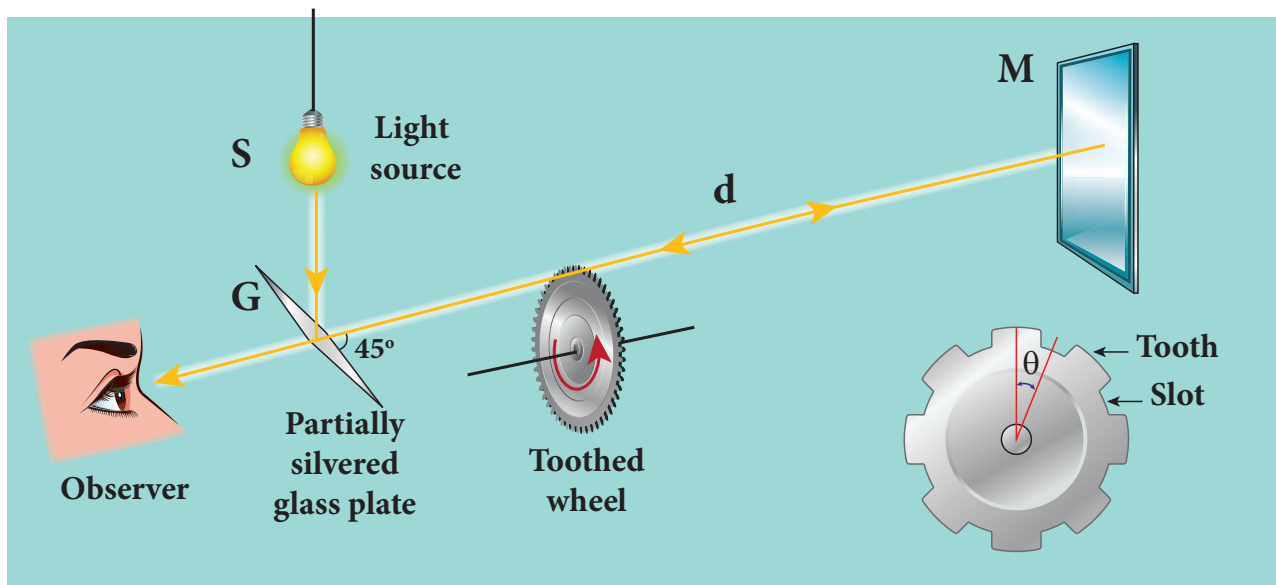

Figure 6.13 Speed of light by Fizeau's method

Substituting for θ in the equation 6.13. for ω ,

$$\omega = \frac{\pi / N}{t} = \frac{\pi}{Nt}$$

Rewriting the above equation for t ,

$$t = \frac{\pi}{N\omega} \quad (6.14)$$

Substituting t from equation (6.14) in equation (6.12),

$$v = \frac{2d}{\pi / N\omega}$$

After rearranging,

$$v = \frac{2dN\omega}{\pi} \quad (6.15)$$

Fizeau had some difficulty to visually estimate the minimum intensity of the light when blocked by the adjacent tooth, and his value for speed of light was very close to the actual value. Later on, with the same idea of Fizeau and with much sophisticated instruments, the speed of light in air was determined as, $v = 2.99792 \times 10^8 \text{ m s}^{-1}$.



Note

After the disappearance of light for the first time while increasing the speed of rotation of the toothed-wheel from zero to ω , on further increase of speed of rotation of the wheel to 2ω , the light would appear again due to the passing of reflected light through the next slot. So, for every odd value of ω , light will disappear (stopped by tooth) and for every even value of ω light will appear (allowed by slot).

6.3.2 Speed of light through different media

Different transparent media like glass, water etc. were introduced in the path of light by scientists like Foucault (1819–1868) and Michelson (1852–1931) to find the speed of light in different media. Even evacuated glass tubes were also introduced in the path of light to find the speed of light in vacuum. It was found that light travels with lesser speed in any medium than its

speed in vacuum. The speed of light in vacuum was determined as, $c = 3 \times 10^8 \text{ m s}^{-1}$. We could notice that the speed of light in vacuum and in air are almost the same.

6.3.3 Refractive index

Refractive index of a transparent medium is defined as the ratio of speed of light in vacuum (or air) to the speed of light in that medium.

$$\left. \begin{array}{l} \text{refractive} \\ \text{index } n \text{ of a} \\ \text{medium} \end{array} \right\} = \frac{\text{speed of light in vacuum } (c)}{\text{speed of light in medium } (v)}$$

$$n = \frac{c}{v} \quad (6.16)$$

Refractive index of a transparent medium gives an idea about the speed of light in that medium.

EXAMPLE 6.5

One type of transparent glass has refractive index 1.5. What is the speed of light through this glass?

Solution

$$n = \frac{c}{v}; \quad v = \frac{c}{n}$$

$$v = \frac{3 \times 10^8}{1.5} = 2 \times 10^8 \text{ m s}^{-1}$$

Light travels with a speed of $2 \times 10^8 \text{ m s}^{-1}$ through this glass.

Refractive index does not have unit. The smallest value of refractive index is for vacuum, which is 1. For any other medium refractive index is greater than 1. Refractive index is also called as optical density of the medium. Higher the refractive index of a medium, greater is its optical density and speed of light through the medium is lesser and vice versa. [Note: optical density

should not be confused with mass density of the material of the medium. They two are different entities]. The Table 6.2 shows the refractive index of different transparent media.

Table 6.2 Refractive index of different media

Media	Refractive index
Vacuum	1.00
Air	1.0003
Carbon dioxide gas	1.0005
Ice	1.31
Pure water	1.33
Ethyl alcohol	1.36
Quartz	1.46
Vegetable oil	1.47
Olive oil	1.48
Acrylic	1.49
Table salt	1.51
Glass	1.52
Sapphire	1.77
Zircon	1.92
Qubic zirconia	2.16
Diamond	2.42
Gallium phosphide	3.50

6.3.4 Optical path

Optical path of a medium is defined as the distance d' light travels in vacuum in the same time it travels a distance d in the medium.

Let us consider a medium of refractive index n and thickness d . Light travels with a speed v through the medium in a time t . Then we can write,

$$v = \frac{d}{t}; \text{ rewritten as, } t = \frac{d}{v}$$

In the same time, light can cover a greater distance d' in vacuum as it travels with greater speed c in vacuum as shown in Figure 6.14. Then we have,

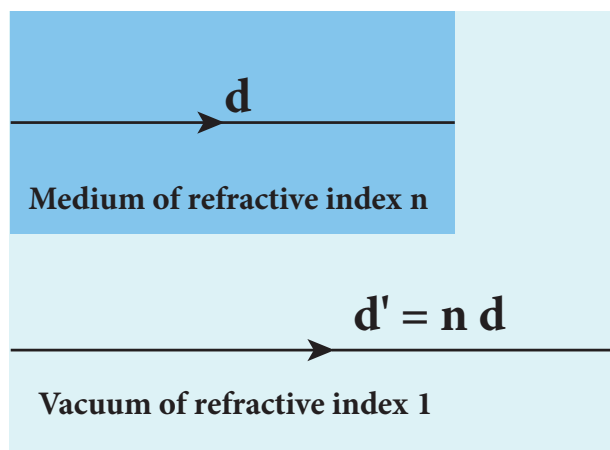

Figure 6.14 Optical path

$$c = \frac{d'}{t}; \text{ rewritten as, } t = \frac{d'}{c}$$

As the time taken in both the cases is the same, we can equate the time t as,

$$\frac{d'}{c} = \frac{d}{v}$$

rewritten for the optical path d' as, $d' = \frac{c}{v}d$

As, $\frac{c}{v} = n$; The optical path d' is,

$$d' = nd \quad (6.17)$$

As n is always greater than 1, the optical path d' of the medium is always greater than d .

EXAMPLE 6.6

Light travels from air in to glass slab of thickness 50 cm and refractive index 1.5.

- What is the speed of light in glass?
- What is the time taken by the light to travel through the glass slab?

- What is the optical path of the glass slab?

Solution

Given, thickness of glass slab, $d = 50 \text{ cm} = 0.5 \text{ m}$, refractive index, $n = 1.5$

refractive index, $n = \frac{c}{v}$

speed of light in glass is,

$$v = \frac{c}{n} = \frac{3 \times 10^8}{1.5} = 2 \times 10^8 \text{ m s}^{-1}$$

Time taken by light to travel through glass slab is,

$$t = \frac{d}{v} = \frac{0.5}{2 \times 10^8} = 2.5 \times 10^{-9} \text{ s}$$

Optical path,

$$d' = nd = 1.5 \times 0.5 = 0.75 \text{ m} = 75 \text{ cm}$$

Light would have travelled 25 cm more (75 cm – 50 cm) in vacuum by the same time had there not been a glass slab.

6.4

REFRACTION

Refraction is passing through of light from one optical medium to another optical medium through a boundary. In refraction, the angle of incidence i in one medium and the angle of reflection r in the other medium are measured with respect to the normal drawn to the surface at the point of incidence of light. Law of refraction is called *Snell's law*.

Snell's law states that,

- The incident ray, refracted ray and normal to the refracting surface are all coplanar (ie. lie in the same plane).
- The ratio of angle of incident i in the first medium to the angle of reflection r in the second medium is equal to the

ratio of refractive index of the second medium n_2 to that of the refractive index of the first medium n_1 .

$$\frac{\sin i}{\sin r} = \frac{n_2}{n_1} \quad (6.18)$$

The above equation is in the ratio form. It can also be written in a much useful product form as,

$$n_1 \sin i = n_2 \sin r \quad (6.19)$$

The refraction at a boundary is shown in Figure 6.15.

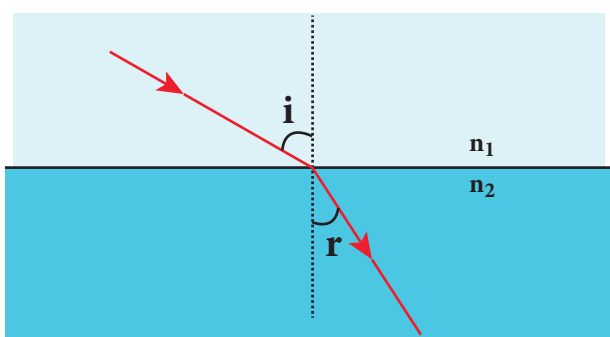

Figure 6.15 Refraction of light



Note

For normal incidence of light on a surface, the angle of incidence is zero.

6.4.1 Angle of deviation due to refraction

We know that the angle between the incident and deviated light is called angle of deviation. When light travels from rarer to denser medium it deviates towards normal as shown in Figure 6.16. The angle of deviation in this case is,

$$d = i - r \quad (6.20)$$

On the other hand, if light travels from denser to rarer medium it deviates away

from normal as shown in Figure 6.17. The angle of deviation in this case is,

$$d = r - i \quad (6.21)$$

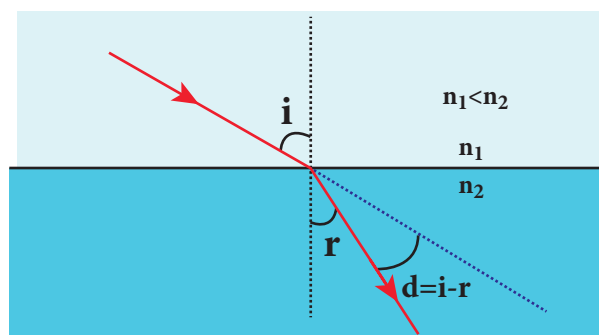

Figure 6.16 Angle of deviation due to refraction from rarer to denser medium

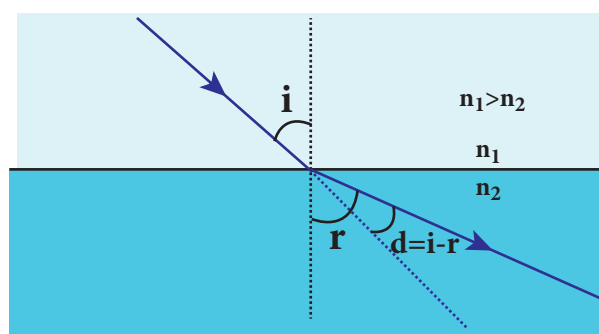

Figure 6.17 Angle of deviation due to refraction from denser to rarer medium

6.4.2 Characteristics of refraction

- When light passes from rarer medium to denser medium it deviates towards normal in the denser medium.
- When light passes from denser medium to rarer medium it deviates away from normal in the rarer medium.
- In any refracting surface there will also be some reflection taking place. Thus, the intensity of refracted light will be lesser than the incident light. **The phenomenon in which a part of light from a source undergoing reflection and the other part of light from the same source undergoing refraction at the same**

surface is called *simultaneous reflection or simultaneous refraction*. This is shown in Figure 6.18. Such surfaces are available as partially silvered glasses.

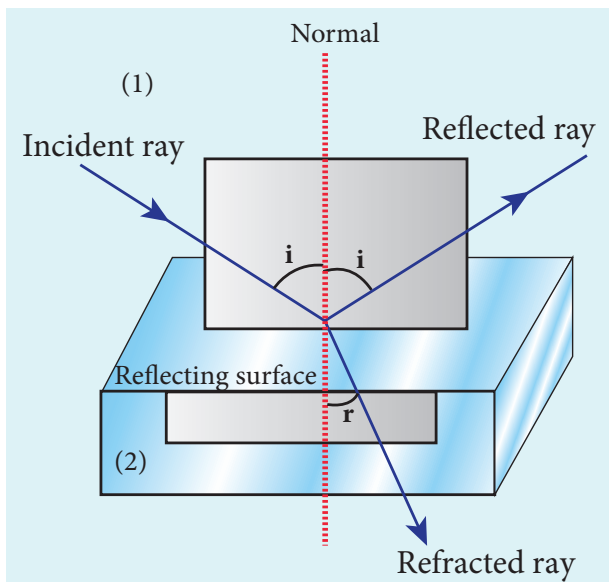

Figure 6.18 Simultaneous reflection and refraction

6.4.3 Principle of reversibility

The *principle of reversibility* states that light will follow exactly the same path if its direction of travel is reversed. This is true for both reflection and refraction as shown in Figure 6.15.

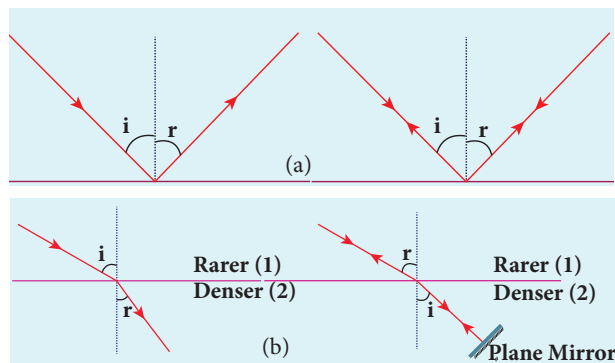
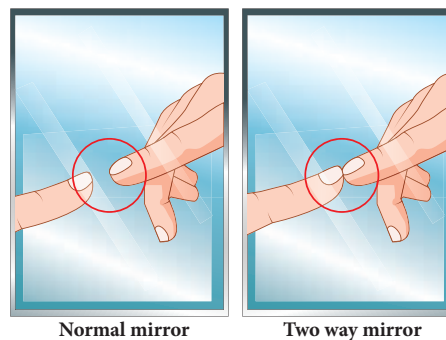
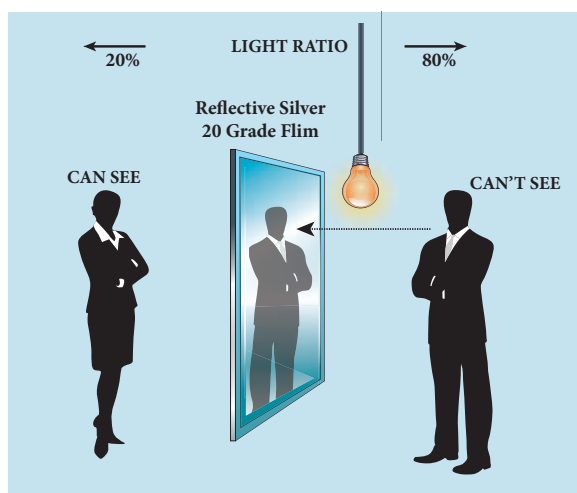

Figure 6.19 Principle of reversibility in (a) reflection and (b) refraction



Production of optical surfaces capable of refracting as well as reflecting is possible by properly coating the surfaces with suitable materials. Thus, a glass can be made partially see through and partially reflecting by varying the amount of coating on its surface. It is commercially called as two way mirror, half-silvered or semi-silvered mirror etc. This gives a perception of regular mirror if the other side is made dark. But, still hidden cameras can be kept behind such mirrors. We need to be cautious when we stand in front of mirrors kept in unknown places. There is a method to test the two way mirror. Place the finger nail against the mirror surface. If there is a gap between nail and its image, then it is a regular mirror. If the fingernail directly touches its image, then it is a two way mirror.



6.4.4 Relative refractive index

In the equation for Snell's law, the term $\left(\frac{n_2}{n_1}\right)$ is called *relative refractive index of second medium with respect to the first medium* which is denoted as (n_{21}) .

$$n_{21} = \frac{n_2}{n_1} \quad (6.22)$$

The concept of relative refractive index gives rise to other useful relation such as,

a) Inverse rule:

$$n_{12} = \frac{1}{n_{21}} \quad (\text{or}) \quad \frac{n_1}{n_2} = \frac{1}{n_2/n_1} \quad (6.23)$$

b) Chain rule:

$$n_{32} = n_{31} \times n_{12} \quad (\text{or}) \quad \frac{n_3}{n_2} = \frac{n_3}{n_1} \times \frac{n_1}{n_2} \quad (6.24)$$

EXAMPLE 6.7

Light travelling through transparent oil enters in to glass of refractive index 1.5. If the refractive index of glass with respect to the oil is 1.25, what is the refractive index of the oil?

Solution

Given, $n_{go} = 1.25$ and $n_g = 1.5$

Refractive index of glass with respect to oil,

$$n_{go} = \frac{n_g}{n_o}$$

Rewriting for refractive index of oil,

$$n_o = \frac{n_g}{n_{go}} = \frac{1.5}{1.25} = 1.2$$

The refractive index of oil is, $n_o = 1.2$

6.4.5 Apparent depth

It is a common observation that the bottom of a tank filled with water appears raised as shown in Figure 6.19(a). An equation could be derived for the apparent depth for viewing in the near normal direction. The ray diagram is shown in Figure 6.19(b) and (c).

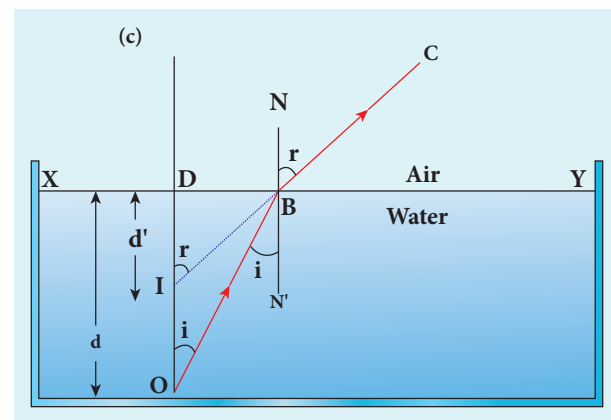
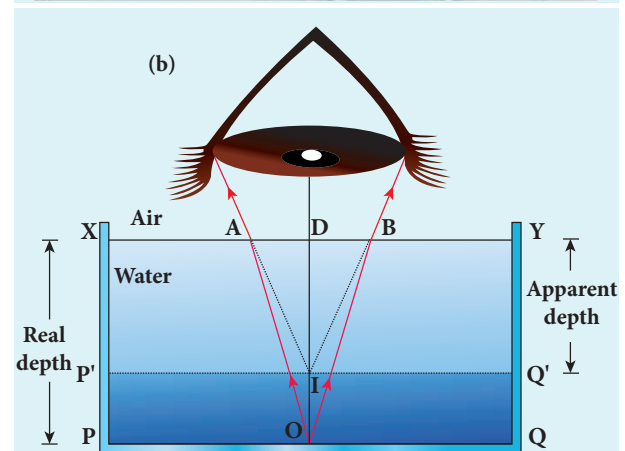

Figure 6.20 Apparent depth

Light from the object O at the bottom of the tank passes from denser medium (water) to rarer medium (air) to reach our

eyes. It deviates away from the normal in the rarer medium at the point of incidence B . The refractive index of the denser medium is n_1 and rarer medium is n_2 . Here, $n_1 > n_2$. The angle of incidence in the denser medium is i and the angle of refraction in the rarer medium is r . The lines NN' and OD are parallel. Thus angle $\angle DIB$ is also r . The angles i and r are very small as the diverging light from O entering the eye is very narrow. The Snell's law in product form for this refraction is,

$$n_1 \sin i = n_2 \sin r \quad (6.19)$$

As the angles i and r are small, we can approximate, $\sin i \approx \tan i$;

$$n_1 \tan i = n_2 \tan r$$

In triangles $\triangle DOB$ and $\triangle DIB$,

$$\tan(i) = \frac{DB}{DO} \text{ and } \tan(r) = \frac{DB}{DI}$$

$$n_1 \frac{DB}{DO} = n_2 \frac{DB}{DI}$$

DB is cancelled on both sides, DO is the actual depth d and DI is the apparent depth d' .

$$n_1 \frac{1}{d} = n_2 \frac{1}{d'}$$

$$\frac{d'}{d} = \frac{n_2}{n_1} \quad (6.25)$$

Rearranging the above equation for the apparent depth d' ,

$$d' = \frac{n_2}{n_1} d \quad (6.26)$$

As the rarer medium is air and its refractive index n_2 can be taken as 1, ($n_2=1$). And the refractive index n_1 of denser medium could then be taken as n , ($n_1=n$).

In that case, the equation for apparent depth becomes,

$$d' = \frac{d}{n} \quad (6.27)$$

The bottom appears to be elevated by $d-d'$,

$$d - d' = d - \frac{d}{n} \text{ or } d - d' = d \left(1 - \frac{1}{n}\right) \quad (6.28)$$

EXAMPLE 6.8

A coin is at the bottom of a trough containing three immiscible liquids of refractive indices 1.3, 1.4 and 1.5 poured one above the other of heights 30 cm, 16 cm, and 20 cm respectively. What is the apparent depth at which the coin appears to be when seen from air medium outside? In which medium the coin will be seen?

Solution

When seen from top, the coin will still appear to be at the bottom with each medium appearing to have shrunk with respect to the air medium outside. This situation is illustrated below.

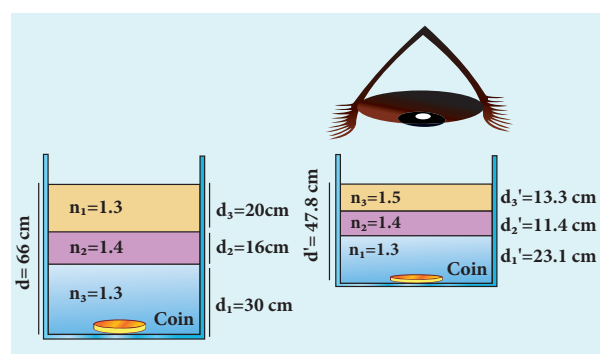

The equations for apparent depth for each medium is,

$$d'_1 = \frac{d_1}{n_1}; \quad d'_2 = \frac{d_2}{n_2}; \quad d'_3 = \frac{d_3}{n_3}$$

$$d' = d'_1 + d'_2 + d'_3 = \frac{d_1}{n_1} + \frac{d_2}{n_2} + \frac{d_3}{n_3}$$



Atmospheric refraction: Due to refraction of light through different layers of atmosphere which vary in refractive index, the path of light deviates continuously when it passes through atmosphere. For example, the Sun is visible a little before the actual sunrise and also until a little after the actual sunset due to refraction of light through the atmosphere. By actual sunrise what we mean is the actual crossing of the sun at the horizon. Figure shows the actual and apparent positions of the sun with respect to the horizon. The figure is highly exaggerated to show the effect. The apparent shift in the direction of the sun is around half a degree and the corresponding time difference between actual and apparent positions is about 2 minutes. Sun appears flattened (oval shaped) during sun rise and sunset due to the same phenomenon.

The same is also applicable for the positions of stars as shown in Figure. The stars actually do not twinkle. They appear twinkling because of the movement of the atmospheric layers with varying refractive indices which is clearly seen in the night sky.

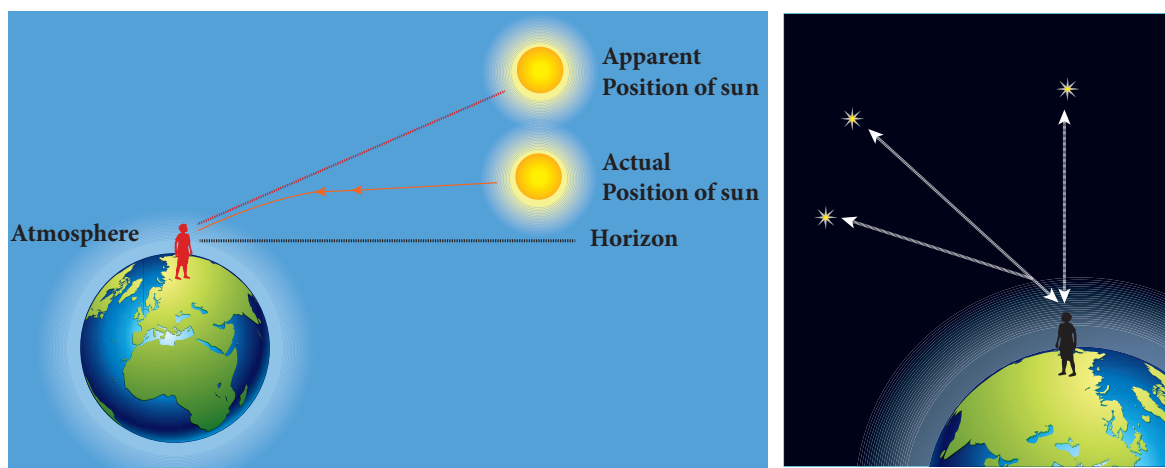

$$d' = \frac{30}{1.3} + \frac{16}{1.4} + \frac{30}{1.5} = 23.1 + 11.4 + 13.3$$

$$d' = 47.8 \text{ cm}$$

6.4.6 Critical angle and total internal reflection

When a ray passes from an optically denser medium to an optically rarer medium, it bends away from normal. Because of this, the angle of refraction r on the rarer medium is greater than the corresponding angle of incidence i in the denser medium. As angle of incidence i is gradually increased, r rapidly increases and at a certain stage it becomes 90° or gracing the boundary. **The angle of**

incidence in the denser medium for which the refracted ray graces the boundary is called *critical angle* i_c .

If the angle of incidence in the denser medium is increased beyond the critical angle, there is no refraction possible into the rarer medium. **The entire light is reflected back into the denser medium itself. This phenomenon is called *total internal reflection*.** These are shown in Figure 6.21.

The two conditions for total internal reflection are,

- light must travel from denser to rarer medium,
- angle of incidence in the denser medium must be greater than critical angle ($i > i_c$).

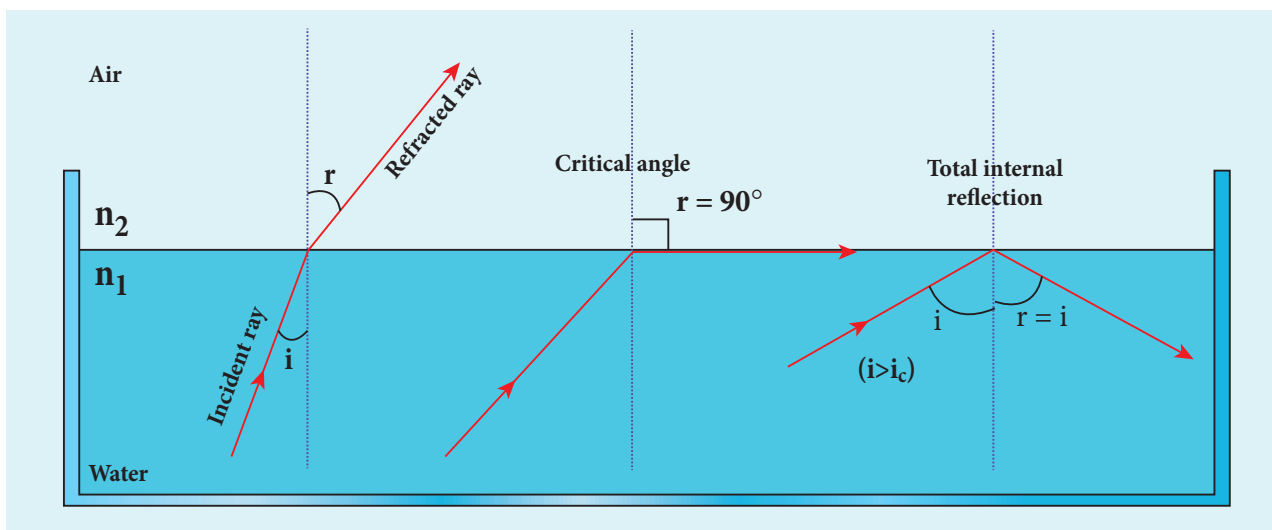

Figure 6.21 Critical angle and total internal reflection

Snell's law in the product form, equation (6.19) for critical angle incidence becomes,

$$n_1 \sin i_c = n_2 \sin 90^\circ \quad (6.29)$$

$$n_1 \sin i_c = n_2 \quad \because \sin 90^\circ = 1$$

$$\sin i_c = \frac{n_2}{n_1} \quad (6.30)$$

Here, $n_1 > n_2$

If the rarer medium is air, then its refractive index is 1 and can be taken as n itself. i.e. ($n_2=1$) and ($n_1=n$).

$$\sin i_c = \frac{1}{n} \text{ (or) } i_c = \sin^{-1} \left(\frac{1}{n} \right) \quad (6.31)$$

For example the refractive index of glass is about 1.5. The critical angle for glass-air interface is, $i_c = \sin^{-1} \left(\frac{1}{1.5} \right) = 41.8^\circ$.

The critical angle for water-air interface is, $i_c = \sin^{-1} \left(\frac{1}{1.3} \right) = 48.6^\circ$.

The critical angle i_c depends on the refractive index of the medium. Table 6.3 shows the refractive index and the critical angle for different materials.

Table 6.3 Refractive index and critical angle of different media

Material	Refractive index	Critical Angle
Ice	1.310	49.8°
Water	1.333	48.6°
Fused Quartz (SiO ₂)	1.458	43.3°
Crown Glass	1.541	40.5°
Flint Glass	1.890	31.9°
Calcite (CaCO ₂)	1.658	37.0°
Diamond	2.417	24.4°
Strontium Titanate (SrTiO ₃)	2.417	24.4°
Rutile	2.621	22.4°

6.4.7 Effects due to total internal reflection

6.4.7.1 Glittering of diamond

Diamond appears dazzling because the total internal reflection of light happens inside the diamond. The refractive index of only diamond is about 2.417. It is much larger than that for ordinary glass which is about only 1.5. The critical angle of diamond is about 24.4°. It is much less than that of

glass. A skilled diamond cutter makes use of this larger range of angle of incidence (24.4° to 90° inside the diamond), to ensure that light entering the diamond is total internally reflected from the many cut faces before getting out as shown in Figure 6.22. This gives a sparkling effect for diamond.

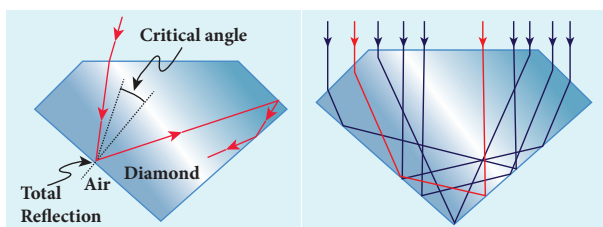

Figure 6.22 Total internal reflection in diamond

6.4.7.2 Mirage and looming

The refractive index of air increases with its density. In hot places, air near the ground is hotter than air at a height. Hot air is less dense. Hence, in still air the refractive index of air increases with height. Because of this, light from tall objects like a tree, passes through a medium whose refractive index decreases towards the ground. Hence, a ray of light successively deviates away from the normal at different layers of air and undergoes total internal reflection when the angle of incidence near the ground exceeds the critical angle. This gives an illusion as if the light comes from somewhere below the ground. For of the shaky nature of the layers of air, the observer feels as if the object is getting reflected by a pool of water or wet surface beneath the object as shown in Figure 6.23(a). This phenomenon is called *mirage*.

In the cold places the refractive index increases towards the ground because the temperature of air close to the ground is lesser than the temperature above the surface of earth. Thus, the density and refractive index of air near the ground is greater than

at a height. In the cold regions like glaciers and frozen lakes and seas, the reverse effect of mirage will happen. Hence, an inverted image is formed little above the surface as shown in Figure 6.23(b). This phenomenon is called *looming*.

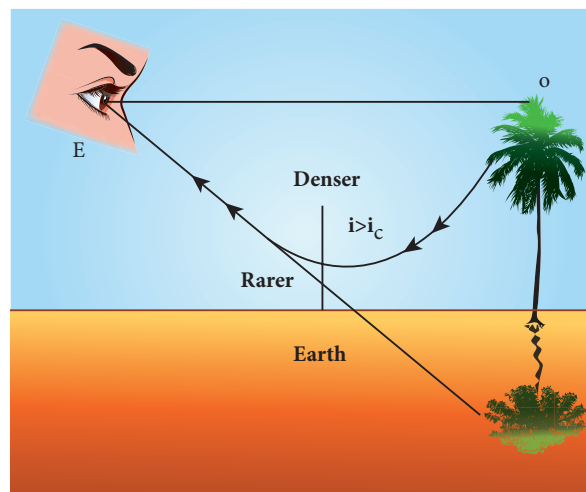

(a) Mirage

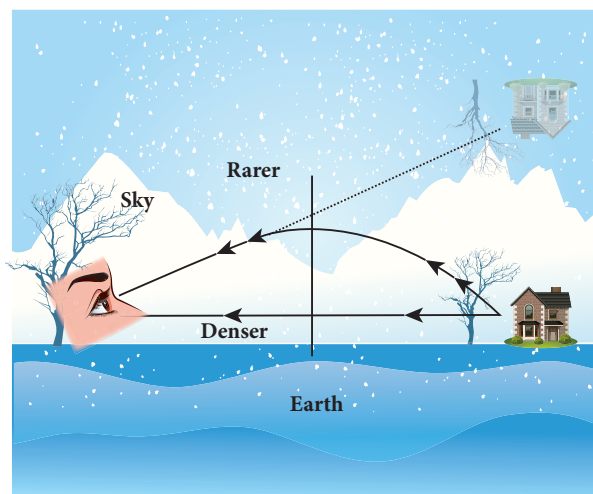

(b) Looming

Figure 6.23 Mirage and looming

6.4.7.3 Prisms making using of total internal reflection

Prisms can be designed to reflect light by 90° or by 180° by making use of total internal reflection as shown in Figure 6.24(a) and (b). In the first two cases, the critical angle i_c for the material of the prism must be less than 45° . We see from Table 6.3 that this is true for both crown glass and

flint glass. Prisms are also used to invert images without changing their size as shown in Figure. 6.24(c).

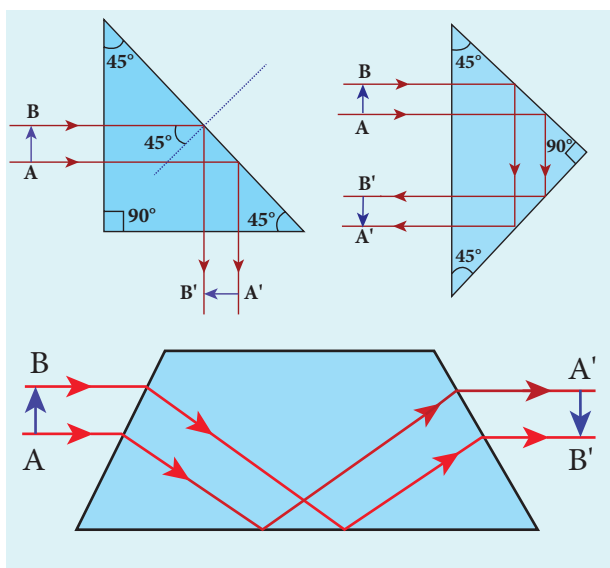

Figure 6.24 Prisms making use of total internal reflection

6.4.7.4 Radius of illumination (Snell's window)

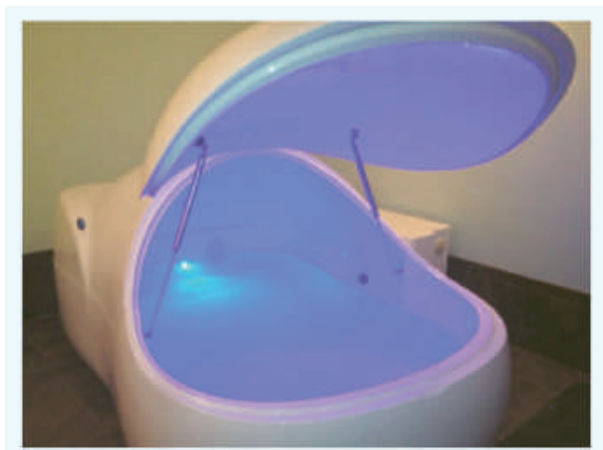

Figure 6.25 Light source inside water tank

When a light source like electric bulb is kept inside a water tank, the light from the source travels in all direction inside the water. The light that is incident on the water surface at an angle less than the critical angle will undergo refraction and emerge out from the water. The light incident at an angle greater than critical angle will

undergo total internal reflection. The light falling particularly at critical angle graces the surface. Thus, the entire surface of water appears illuminated when seen from outside as shown in Figure 6.25.

On the other hand, when light entering the water from outside is seen from inside the water, the view is restricted to a particular angle equal to the critical angle i_c . The restricted illuminated circular area is called *Snell's window* as shown in Figure 6.26(a). The Figure 6.26(b) shows the angle of view for water animals.

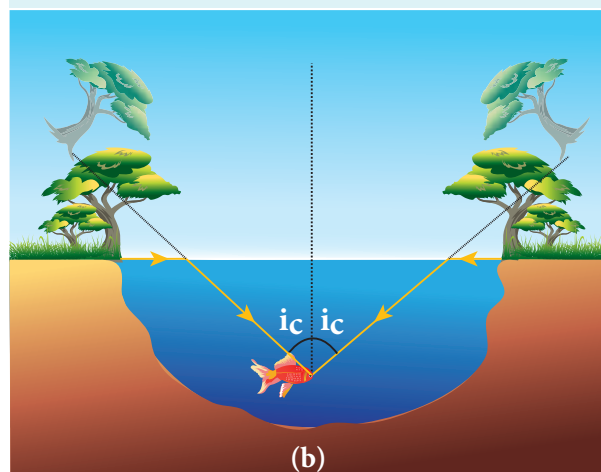

Figure 6.26 (a) Snell's window and (b) angle of view for water animals

The angle of view for water animals is restricted to twice the critical angle $2i_c$. The critical angle for water is 48.6° . Thus the angle of view is 97.2° . The radius R of the circular area depends on the depth d from which it

is seen and also the refractive indices of the media. The radius of Snell's window can be deduced with the illustration as shown in Figure 6.27.

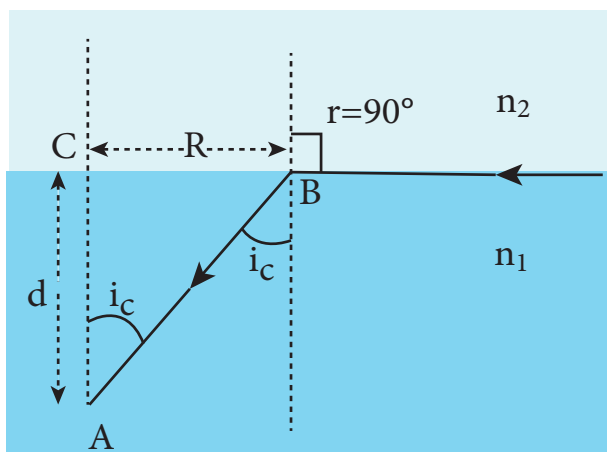

Figure 6.27 Radius of Snell's window

Light is seen from a point A at a depth d . The Snell's law in product form, equation (6.19) for the refraction happening at the point B on the boundary between the two media is,

$$n_1 \sin i_c = n_2 \sin 90^\circ \quad (6.32)$$

$$n_1 \sin i_c = n_2 \quad \because \sin 90^\circ = 1$$

$$\sin i_c = \frac{n_2}{n_1} \quad (6.33)$$

From the right angle triangle ΔABC ,

$$\sin i_c = \frac{CB}{AB} = \frac{R}{\sqrt{d^2 + R^2}} \quad (6.34)$$

Equating the above two equation 6.34 and equation 6.35, $\frac{R}{\sqrt{d^2 + R^2}} = \frac{n_2}{n_1}$

$$\text{Squaring on both sides, } \frac{R^2}{R^2 + d^2} = \left(\frac{n_2}{n_1}\right)^2$$

$$\text{Taking reciprocal, } \frac{R^2 + d^2}{R^2} = \left(\frac{n_1}{n_2}\right)^2$$

On further simplifying,

$$1 + \frac{d^2}{R^2} = \left(\frac{n_1}{n_2}\right)^2; \quad \frac{d^2}{R^2} = \left(\frac{n_1}{n_2}\right)^2 - 1;$$

$$\frac{d^2}{R^2} = \frac{n_1^2}{n_2^2} - 1 = \frac{n_1^2 - n_2^2}{n_2^2}$$

Again taking reciprocal and rearranging,

$$\frac{R^2}{d^2} = \frac{n_2^2}{n_1^2 - n_2^2}; \quad R^2 = d^2 \left(\frac{n_2^2}{n_1^2 - n_2^2}\right)$$

The radius of illumination is,

$$R = d \sqrt{\frac{n_2^2}{n_1^2 - n_2^2}} \quad (6.35)$$

If the rarer medium outside is air, then, $n_2 = 1$, and we can take $n_1 = n$

$$R = d \left(\frac{1}{\sqrt{n^2 - 1}}\right) \quad (\text{or}) \quad R = \frac{d}{\sqrt{n^2 - 1}} \quad (6.36)$$

EXAMPLE 6.9

What is the radius of the illumination when seen above from inside a swimming pool from a depth of 10 m on a sunny day? What is the total angle of view? [Given, refractive index of water is $4/3$]

Solution

Given, $n = 4/3$, $d = 10$ m.

Radius of illumination, $R = \frac{d}{\sqrt{n^2 - 1}}$

$$R = \frac{10}{\sqrt{(4/3)^2 - 1}} = \frac{10 \times 3}{\sqrt{16 - 9}}$$

$$R = \frac{30}{\sqrt{7}} = 11.32 \text{ m}$$

To find the angle of the view of the cone,

$$i_c = \sin^{-1} \left(\frac{1}{n}\right)$$

$$i_c = \sin^{-1} \left(\frac{1}{4/3}\right) = \sin^{-1} \left(\frac{3}{4}\right) = 48.6^\circ$$

The total angle of view is,

$$2i_c = 2 \times 48.6^\circ = 97.2^\circ$$

6.4.7.5 Optical fiber

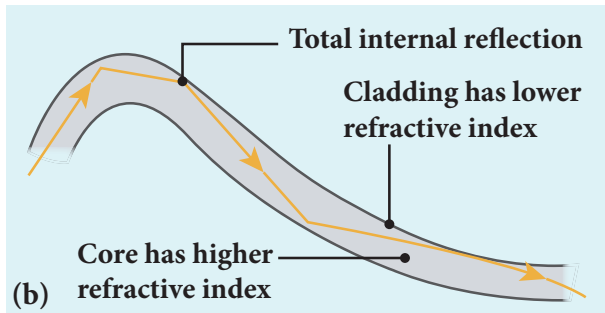
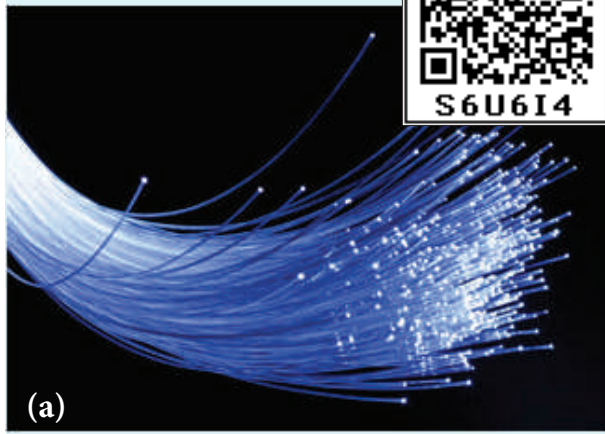

Figure 6.28 Optical fibre

Transmitting signals through optical fibres is possible due to the phenomenon of total internal reflection. **Optical fibres consists of inner part called core and outer part called cladding (or) sleeving.** The refractive index of the material of the core must be higher than that of the cladding for total internal reflection to happen. Signal in the form of light is made to incident inside the core-cladding boundary at an angle greater than the critical angle. Hence, it undergoes repeated total internal reflections along the length of the fibre without undergoing any refraction. The light travels inside the core with no appreciable loss in the intensity of the light as shown in Figure 6.28(a). Even while bending the optic fiber, it is done in such a way that the condition

for total internal reflection is ensured at every reflection as shown in Figure 6.28(b).

6.4.7.6 Acceptance angle in optical fibre

To ensure the critical angle incidence in the core-cladding boundary inside the optical fibre, the light should be incident at a certain angle at the end of the optical fiber while entering in to it. This angle is called **acceptance angle**. It depends on the refractive indices of the core n_1 , cladding n_2 and the outer medium n_3 . Assume the light is incident at an angle called acceptance angle i_a at the outer medium and core boundary at A.

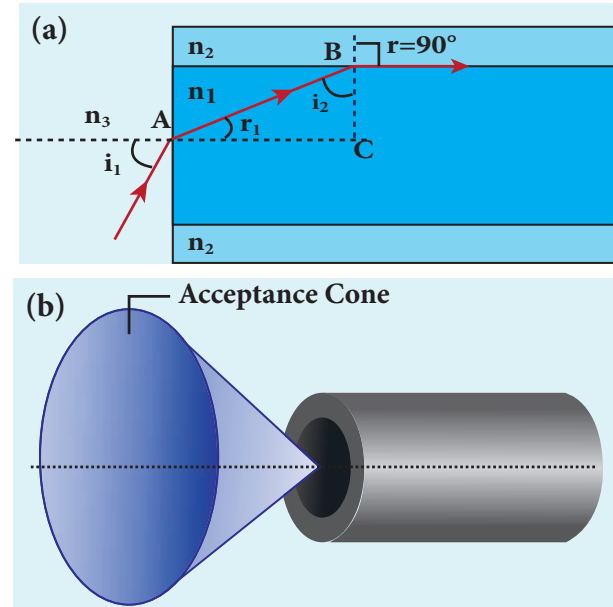

Figure 6.29 (a) acceptance angle and (b) acceptance cone.

The Snell's law in the product form, equation (6.19) for this refraction at the point A is as shown in the Figure 6.29(a),

$$n_3 \sin i_a = n_1 \sin r_a \quad (6.37)$$

To have the total internal reflection inside optical fibre, the angle of incidence at the core-cladding interface at B should be atleast critical angle i_c . Snell's law in the product form, equation (6.19) for the refraction at point B is,

$$n_1 \sin i_c = n_2 \sin 90^\circ \quad (6.38)$$

$$n_1 \sin i_c = n_2 \quad \because \sin 90^\circ = 1$$

$$\therefore \sin i_c = \frac{n_2}{n_1} \quad (6.39)$$

From the right angle triangle ΔABC ,

$$i_c = 90^\circ - r_a$$

Now, equation (6.39) becomes,

$$\sin(90^\circ - r_a) = \frac{n_2}{n_1}$$

$$\text{Using trigonometry, } \cos r_a = \frac{n_2}{n_1} \quad (6.40)$$

$$\sin r_a = \sqrt{1 - \cos^2 r_a}$$

Substituting for $\cos r_a$

$$\sin r_a = \sqrt{1 - \left(\frac{n_2}{n_1}\right)^2} = \sqrt{\frac{n_1^2 - n_2^2}{n_1^2}} \quad (6.41)$$

Substituting this in equation (6.37).

$$n_3 \sin i_a = n_1 \sqrt{\frac{n_1^2 - n_2^2}{n_1^2}} = \sqrt{n_1^2 - n_2^2} \quad (6.42)$$

On further simplification,

$$\sin i_a = \frac{\sqrt{n_1^2 - n_2^2}}{n_3} \quad (\text{or}) \quad \sin i_a = \sqrt{\frac{n_1^2 - n_2^2}{n_3^2}} \quad (6.43)$$

$$i_a = \sin^{-1} \left(\sqrt{\frac{n_1^2 - n_2^2}{n_3^2}} \right) \quad (6.44)$$

If outer medium is air, then $n_3 = 1$. The acceptance angle i_a becomes,

$$i_a = \sin^{-1} \left(\sqrt{n_1^2 - n_2^2} \right) \quad (6.45)$$

Light can have any angle of incidence from 0 to i_a with the normal at the end of the optical fibre forming a conical shape called **acceptance cone** as shown in Figure 6.29(b). In the equation (6.42), **the term $(n_3 \sin i_a)$ is**

called numerical aperture NA of the optical fibre.

$$NA = n_3 \sin i_a = \sqrt{n_1^2 - n_2^2} \quad (6.46)$$

If outer medium is air, then $n_3 = 1$. The numerical aperture NA becomes,

$$NA = \sin i_a = \sqrt{n_1^2 - n_2^2} \quad (6.47)$$

EXAMPLE 6.10

A optical fibre is made up of a core material with refractive index 1.68 and a cladding material of refractive index 1.44. What is the acceptance angle of the fibre kept in air medium? What is the answer if there is no cladding?

Solution

Given, $n_1 = 1.68$, $n_2 = 1.44$, $n_3 = 1$

Acceptance angle, $i_a = \sin^{-1} \left(\sqrt{n_1^2 - n_2^2} \right)$

$$i_a = \sin^{-1} \left(\sqrt{(1.68)^2 - (1.44)^2} \right) = \sin^{-1}(0.865)$$

$$i_a \approx 60^\circ$$

If there is no cladding then, $n_2 = 1$

Acceptance angle, $i_a = \sin^{-1} \left(\sqrt{n_1^2 - 1} \right)$

$$i_a = \sin^{-1} \left(\sqrt{(1.68)^2 - 1} \right) = \sin^{-1}(1.35)$$

\sin^{-1} (more than 1) is not possible. But, this includes the range 0° to 90° . Hence, all the rays entering the core from flat surface will undergo total internal reflection.

Note: If there is no cladding then there is a condition on the refractive index (n_1) of the core.

$$i_a = \sin^{-1} \left(\sqrt{n_1^2 - 1} \right)$$

Here, as per mathematical rule, $(n_1^2 - 1) \leq 1$ or $(n_1^2) \leq 2$

$$\text{or } n_1 \leq \sqrt{2}$$

Hence, in air (no cladding) the refractive index n_1 of the core should be, $n_1 \leq 1.414$



An endoscope is an instrument used by doctors which has a bundle of optical fibres that are used to see inside a patient's body. Endoscopes work on the phenomenon of total internal reflection. The optical fibres are inserted in to the body through mouth, nose or a special hole made in the body. Even operations could be carried out with the endoscope cable which has the necessary instruments attached at their ends.

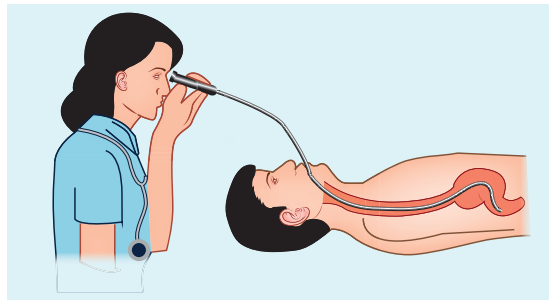
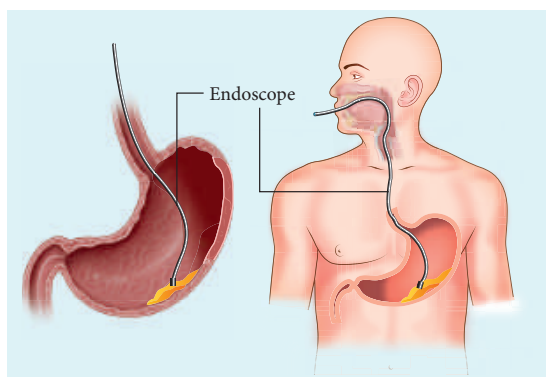

6.4.8 Refraction in glass slab

When a ray of light passes through a glass slab it refracts at two refracting surfaces. When the light ray enters the slab it travels from rarer medium (air) to denser medium (glass). This results in deviation of ray towards the normal. When the light ray

leaves the slab it travels from denser medium to rarer medium resulting in deviation of ray away from the normal. After the two refractions, the emerging ray has the same direction as that of the incident ray on the slab with a lateral displacement or shift L . i.e. There is no change in the direction of ray but the path of the incident ray and refracted ray are different and parallel to each other. To calculate the lateral displacement, a perpendicular is drawn in between the paths of incident ray and refracted ray as shown in Figure 6.30.

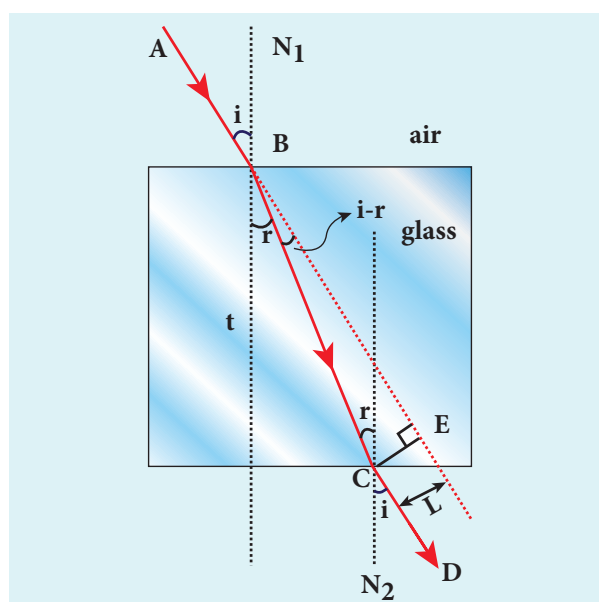

Figure 6.30 Refraction in glass slab

Consider a glass slab of thickness t and refractive index n is kept in air medium. The path of the light is $ABCD$ and the refractions occur at two points B and C in the glass slab. The angles of incidence i and refraction r are measured with respect to the normal N_1 and N_2 at the two points B and C respectively. The lateral displacement L is the perpendicular distance CE drawn between the path of light and the undeviated path of light at point C .

In the right angle triangle $\triangle BCE$,

$$\sin(i - r) = \frac{L}{BC}; BC = \frac{L}{\sin(i - r)} \quad (6.48)$$

In the right angle triangle $\triangle BCF$,

$$\cos(r) = \frac{t}{BC}; BC = \frac{t}{\cos(r)} \quad (6.49)$$

Equating equations (6.48) and (6.49),

$$\frac{L}{\sin(i-r)} = \frac{t}{\cos(r)}$$

After rearranging,

$$L = t \left(\frac{\sin(i-r)}{\cos(r)} \right) \quad (6.50)$$

Lateral displacement depends upon the thickness of the slab. Thicker the slab, greater will be the lateral displacement. Greater the angle of incidence, larger will be the lateral displacement.

EXAMPLE 6.11

The thickness of a glass slab is 0.25 m. it has a refractive index of 1.5. A ray of light is incident on the surface of the slab at an angle of 60° . Find the lateral displacement of the light when it emerges from the other side of the mirror.

Solution

Given, thickness of the slab, $t = 0.25$ m, refractive index, $n = 1.5$, angle of incidence, $i = 60^\circ$.

Using Snell's law, $1 \times \sin i = n \sin r$

$$\sin r = \frac{\sin i}{n} = \frac{\sin 60}{1.5} = 0.58$$

$$r = \sin^{-1} 0.58 = 35.25^\circ$$

Lateral displacement is, $L = t \left(\frac{\sin(i-r)}{\cos(r)} \right)$

$$L = (0.25) \times \left(\frac{\sin(60 - 35.25)}{\cos(35.25)} \right) = 0.1281 \text{ m}$$

The lateral displacement is, $L = 12.81 \text{ cm}$

6.5

REFRACTION AT SINGLE SPHERICAL SURFACE

We have so far studied only the refraction at a plane surfaces. The refractions also do take place at spherical surface between two transparent media. The laws of refraction hold good at every point on the spherical surface. The normal at the point of incidence is perpendicular to the tangent plane to the spherical surface at that point. Therefore, the normal always passes through its center of curvature. The study of refraction at single spherical surface paves way to the understanding of thin lenses which consist of two surfaces of which one or both must be spherical.

The following assumptions are made while considering refraction at spherical surfaces.

- The incident light is assumed to be monochromatic (single colour)
- The incident ray of light is very close to the principal axis (paraxial rays).

The sign conventions are similar to that of the spherical mirrors.

6.5.1 Equation for refraction at single spherical surface

Let us consider two transparent media having refractive indices n_1 and n_2 are separated by a spherical surface as shown in Figure 6.31. Let C be the centre of curvature of the spherical surface. Let a point object O be in the medium n_1 . The line OC cuts the spherical surface at the pole P of the surface. As the rays considered are paraxial rays, the perpendicular dropped for the point of incidence to the principal axis is very close to the pole or passes through the pole itself.

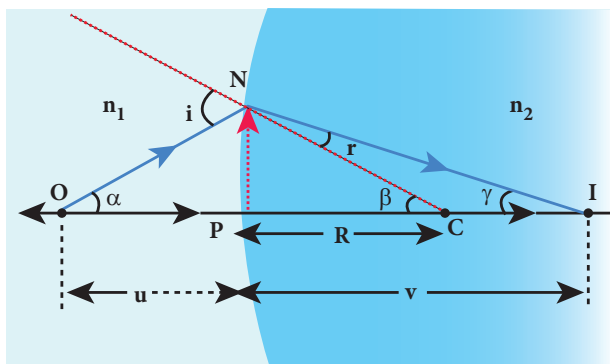

Figure 6.31 Refraction at single spherical surface

Light from O falls on the refracting surface at N . The normal drawn at the point of incidence passes through the centre of curvature C . As $n_2 > n_1$, light in the denser medium deviates towards the normal and meets the principal axis at I where the image is formed.

Snell's law in product form for the refraction at the point N could be written as,

$$n_1 \sin i = n_2 \sin r \quad (6.19)$$

As the angles are small, sine of the angle could be approximated to the angle itself.

$$n_1 i = n_2 r \quad (6.51)$$

Let the angles,

$$\angle NOP = \alpha, \angle NCP = \beta, \angle NIP = \gamma$$

$$\tan \alpha = \frac{PN}{PO}; \quad \tan \beta = \frac{PN}{PC}; \quad \tan \gamma = \frac{PN}{PI}$$

As these angles are small, tan of the angle could be approximated to the angle itself.

$$\alpha = \frac{PN}{PO}; \quad \beta = \frac{PN}{PC}; \quad \gamma = \frac{PN}{PI} \quad (6.52)$$

For the triangle, $\triangle ONC$,

$$i = \alpha + \beta \quad (6.53)$$

For the triangle, $\triangle INC$,

$$\beta = r + \gamma \text{ (or) } r = \beta - \gamma \quad (6.54)$$

Substituting for i and r from equations (6.53) and (6.54) in the equation (6.51).

$$n_1(\alpha + \beta) = n_2(\beta - \gamma)$$

Rearranging,

$$n_1\alpha + n_2\gamma = (n_2 - n_1)\beta$$

Substituting for α , β and γ from equation (6.52),

$$n_1 \left(\frac{PN}{PO} \right) + n_2 \left(\frac{PN}{PI} \right) = (n_2 - n_1) \left(\frac{PN}{PC} \right)$$

Further simplifying by cancelling PN ,

$$\frac{n_1}{PO} + \frac{n_2}{PI} = \frac{n_2 - n_1}{PC} \quad (6.55)$$

Following sign conventions, $PO = -u$, $PI = +v$ and $PC = +R$ in equation (6.55),

$$\frac{n_1}{-u} + \frac{n_2}{v} = \frac{(n_2 - n_1)}{R}$$

After rearranging, finally we get,

$$\frac{n_2}{v} - \frac{n_1}{u} = \frac{(n_2 - n_1)}{R} \quad (6.56)$$

Equation (6.56) gives the relation among the object distance u , image distance v , refractive indices of the two media (n_1 and n_2) and the radius of curvature R of the spherical surface. It holds for any spherical surface.

If the first medium is air then, $n_1 = 1$ and the second medium is taken just as $n_2 = n$, then the equation is reduced to,

$$\frac{n}{v} - \frac{1}{u} = \frac{(n-1)}{R} \quad (6.57)$$

EXAMPLE 6.12

Locate the image of the point object O in the situation shown. The point C denotes

the centre of curvature of the separating surface.

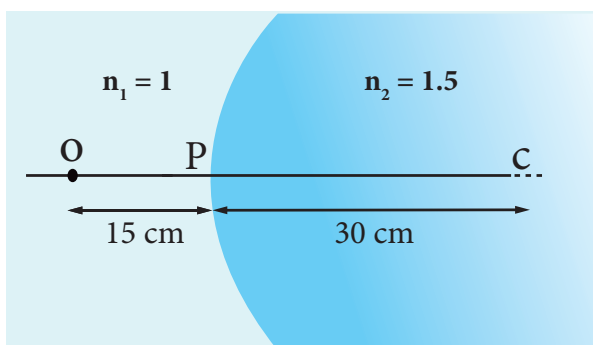

Solution

Given, $u = -15$ cm, $R = 30$ cm, $n_1 = 1$ and $n_2 = 1.5$

Equation for single spherical surface is,

$$\frac{n_2}{v} - \frac{n_1}{u} = \frac{(n_2 - n_1)}{R}$$

Substituting the values,

$$\frac{1.5}{v} - \frac{1}{-15} = \frac{(1.5 - 1)}{30}; \quad \frac{1.5}{v} + \frac{1}{15} = \frac{0.5}{30}$$

$$\frac{1.5}{v} + \frac{1}{15} = \frac{1}{60}; \quad \frac{1.5}{v} = \frac{1}{60} - \frac{1}{15};$$

$$\frac{1.5}{v} = \frac{1 - 4}{60} = \frac{-3}{60}; \quad = -\frac{1}{20}$$

$$v = -30 \text{ cm}$$

The image is a virtual image formed 30 cm to the left of the spherical surface.

6.5.2 Lateral magnification in single spherical surface

Let us, consider an extended object OO' is kept perpendicular to the principal axis to the left of the single spherical surface as shown in Figure 6.32. The image formed on the other side of the surface is $I'I'$. Consider a ray from O' in the first medium towards C in the second medium. As this ray is incident normal to the spherical surface, it

goes undeviated in the second medium. The position of image may be located using the Equation (6.60).

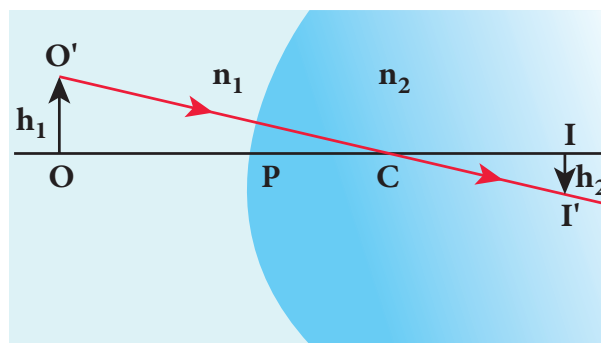

Figure 6.32 Lateral magnification in single spherical surface

The lateral or transverse magnification m is defined as the ratio of height of the image to the height of the object.

$$m = \frac{II'}{OO'} \quad (6.58)$$

From the two similar triangles $\triangle COO'$ and $\triangle CII'$, we can write,

$$\frac{II'}{OO'} = \frac{CI}{CO}$$

From the geometry,

$$\frac{CI}{CO} = \frac{PI - PC}{PC + PO}$$

Hence,

$$m = \frac{II'}{OO'} = \frac{PI - PC}{PC + PO} \quad (6.59)$$

Applying sign conventions in the above equation (6.59),

$$II' = -h_2, \quad OO' = h_1, \quad PI = +v, \\ PC = +R, \quad PO = -u$$

Where, h_1 is the height of the object and h_2 is the height of the image.

$$m = \frac{-h_2}{h_1} = \frac{v - R}{R + (-u)}; \quad m = \frac{h_2}{h_1} = -\left(\frac{v - R}{R - u}\right)$$

After rearranging,

$$m = \frac{h_2}{h_1} = \frac{R - v}{R - u} \quad (6.60)$$

We can also arrive at an equation for lateral magnification involving the refractive indices of the two media.

Let us consider the equation for single spherical surface as,

$$\frac{n_2}{v} - \frac{n_1}{u} = \frac{(n_2 - n_1)}{R}$$

Further simplifying, $\frac{n_2 u - n_1 v}{vu} = \frac{(n_2 - n_1)}{R}$

Rewriting for R , $R = \frac{(n_2 - n_1)vu}{n_2 u - n_1 v}$

Rearranging,

$$R - u = \frac{n_2 u (v - u)}{n_2 u - n_1 v} \quad (6.61)$$

$$R - v = \frac{n_1 v (v - u)}{n_2 u - n_1 v} \quad (6.62)$$

Substituting equations (6.61) and (6.62) in equation (6.60) we get the equation for lateral magnification as,

$$m = \frac{h_2}{h_1} = \frac{n_1 v}{n_2 u} \quad (6.63)$$

EXAMPLE 6.13

Find the size of the image formed in the given figure.

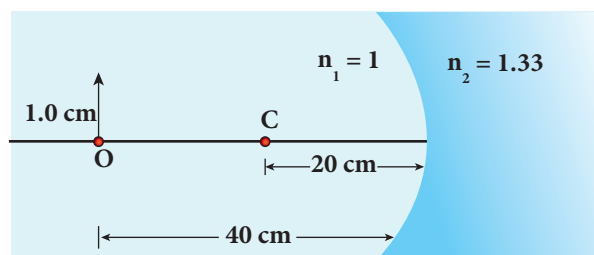

Solution

Given, $u = -40$ cm, $R = -20$ cm, $n_1 = 1$ and $n_2 = 1.33$

Equation for single spherical surface is,

$$\frac{n_2}{v} - \frac{n_1}{u} = \frac{(n_2 - n_1)}{R}$$

Substituting the values,

$$\frac{1.33}{v} - \frac{1}{-40} = \frac{(1.33 - 1)}{-20}; \quad \frac{1.33}{v} + \frac{1}{40} = \frac{(0.33)}{-20}$$

$$\frac{1.33}{v} = -\frac{(0.33)}{20} - \frac{1}{40};$$

$$\frac{1.33}{v} = \frac{-0.66 - 1}{40} = -\frac{1.66}{40}$$

$$v = -40 \times \frac{1.33}{1.66} = -32.0 \text{ cm}$$

Equation for magnification is, $m = \frac{h_2}{h_1} = \frac{n_1 v}{n_2 u}$

$$\frac{h_2}{1.0} = \frac{(1.0) \times (-32)}{(1.33) \times (-40)} = 0.6 \text{ cm (or) } h_2 = 0.6 \text{ cm}$$

The erect virtual image of height 0.6 cm is formed at 32.0 cm to the left of the single spherical surface.

6.6

THIN LENS

A lens is formed by a transparent material bounded between two spherical surfaces or one plane and another spherical surface. In a thin lens, the distance between the surfaces is very small. If there are two spherical surfaces, then there will be two centres of curvature C_1 and C_2 and correspondingly two radii of curvature R_1 and R_2 . A plane surface has its center of curvature C at infinity and its radius of curvature R is infinity ($R = \infty$). The terminologies of spherical mirrors also hold good very much for thin lens except for focal length.

6.6.1 Primary and secondary focal points

As the thin lens is formed by two spherical surfaces, the lens may separate two different media. i.e. the media to the left and right of the lens may be different. Hence, we have two focal lengths.

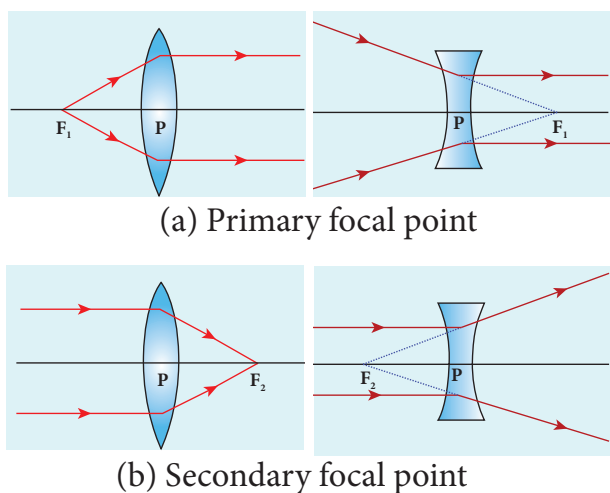

Figure 6.33 Focal length of convex and concave lenses

The **primary focus** F_1 is defined as a point where an object should be placed to give parallel emergent rays to the principal axis as shown in Figure 6.33(a). For a convergent lens, such an object is a real object and for a divergent lens, it is a virtual object. The distance PF_1 is the **primary focal length** f_1 .

The **secondary focus** F_2 is defined as a point where all the parallel rays travelling close to the principal axis converge to form an image on the principal axis as shown in Figure 6.33(b). For a convergent lens, such an image is a real image and for a divergent lens, it is a virtual image. The distance PF_2 is the secondary focal length f_2 .

If the media on the two sides of a thin lens have same refractive index, then the two focal lengths are equal. We will mostly be using the secondary focus F_2 in our further discussions.

6.6.2 Sign conventions for lens on focal length

The sign conventions for thin lenses differ only in the signs followed for focal lengths.

- The sign of focal length is *not decided* on the direction of measurement of the focal length from the pole of the lens as they have two focal lengths, one to the left and another to the right (primary and secondary focal lengths on either side of the lens).
- The focal length of the thin lens is taken as positive for a converging lens and negative for a diverging lens.

The other sign conventions for object distance, image distance, radius of curvature, object height and image height (except for the focal lengths as mentioned above) remain the same for thin lenses as that of spherical mirrors.

6.6.3 Lens maker's formula and lens equation

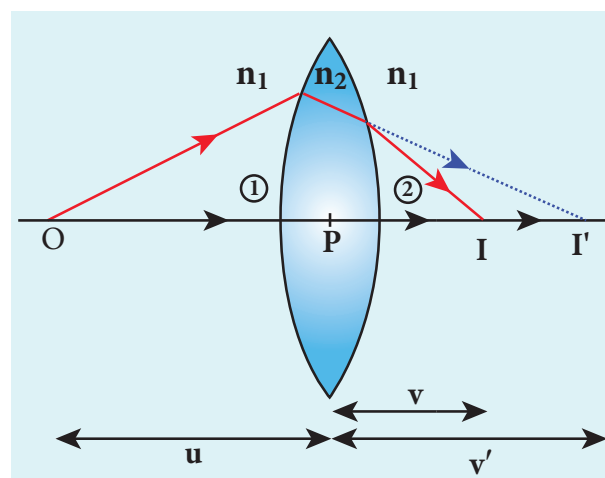

Figure 6.34 Refraction through thin lens

Let us consider a thin lens made up of a medium of refractive index n_2 is placed in a medium of refractive index n_1 . Let R_1 and R_2 be the radii of curvature of two spherical

surfaces ① and ② respectively and P be the pole as shown in figure 6.34. Consider a point object O on the principal axis. The ray which falls very close to P , after refraction at the surface ① forms image at I' . Before it does so, it is again refracted by the surface ②. Therefore the final image is formed at I .

The general equation for the refraction at a spherical surface is given from Equation (6.59),

$$\frac{n_2}{v} - \frac{n_1}{u} = \frac{(n_2 - n_1)}{R}$$

For the refracting surface ①, the light goes from n_1 to n_2 .

$$\frac{n_2}{v'} - \frac{n_1}{u} = \frac{(n_2 - n_1)}{R_1} \quad (6.64)$$

For the refracting surface ②, the light goes from medium n_2 to n_1 .

$$\frac{n_1}{v} - \frac{n_2}{v'} = \frac{(n_1 - n_2)}{R_2} \quad (6.65)$$

Adding the above two equations (6.64) and (6.65)

$$\frac{n_1}{v} - \frac{n_1}{u} = (n_2 - n_1) \left(\frac{1}{R_1} - \frac{1}{R_2} \right)$$

Further simplifying and rearranging,

$$\frac{1}{v} - \frac{1}{u} = \left(\frac{n_2 - n_1}{n_1} \right) \left(\frac{1}{R_1} - \frac{1}{R_2} \right)$$

$$\frac{1}{v} - \frac{1}{u} = \left(\frac{n_2}{n_1} - 1 \right) \left(\frac{1}{R_1} - \frac{1}{R_2} \right) \quad (6.66)$$

If the object is at infinity, the image is formed at the focus of the lens. Thus, for $u = \infty$, $v = f$. Then the equation becomes.

$$\frac{1}{f} - \frac{1}{\infty} = \left(\frac{n_2}{n_1} - 1 \right) \left(\frac{1}{R_1} - \frac{1}{R_2} \right)$$

$$\frac{1}{f} = \left(\frac{n_2}{n_1} - 1 \right) \left(\frac{1}{R_1} - \frac{1}{R_2} \right) \quad (6.67)$$

If the refractive index of the lens is n_2 and it is placed in air, then $n_2 = n$ and $n_1 = 1$. So the equation (6.67) becomes,

$$\frac{1}{f} = (n - 1) \left(\frac{1}{R_1} - \frac{1}{R_2} \right) \quad (6.68)$$

The above equation is called the **lens maker's formula**, because it tells the lens manufactures what curvature is needed to make a lens of desired focal length with a material of particular refractive index. This formula holds good also for a concave lens. By comparing the equations (6.66) and (6.67) we can write,

$$\frac{1}{v} - \frac{1}{u} = \frac{1}{f} \quad (6.69)$$

This equation is known as **lens equation** which relates the object distance u and image distance v with the focal length f of the lens. This formula holds good for a any type of lens.

6.6.4 Lateral magnification in thin lens

Let us consider an object OO' of height h_1 placed on the principal axis with its height perpendicular to the principal axis as shown in Figure 6.35. The ray OP passing through the pole of the lens goes undeviated. The inverted real image II' formed has a height h_2 .

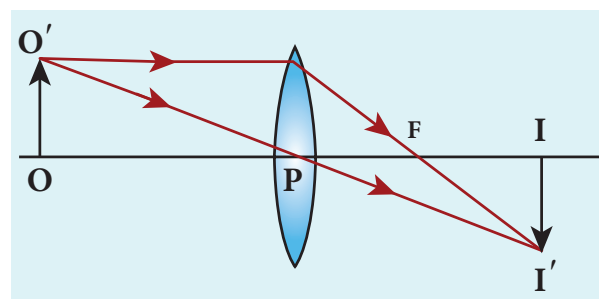

Figure 6.35 Lateral magnification in thin lens

The lateral or transverse magnification m is defined as the ratio of the height of the image to that of the object.

$$m = \frac{II'}{OO'} \quad (6.70)$$

From the two similar triangles $\triangle POO'$ and $\triangle PII'$, we can write,

$$\frac{II'}{OO'} = \frac{PI}{PO} \quad (6.71)$$

Applying sign convention,

$$\frac{-h_2}{h_1} = \frac{v}{-u}$$

Substituting this in the equation (6.70) for magnification,

$$m = \frac{-h_2}{h_1} = \frac{v}{-u}$$

After rearranging,

$$m = \frac{h_2}{h_1} = \frac{v}{u} \quad (6.72)$$

The magnification is negative for real image and positive for virtual image. In the case of a concave lens, the magnification is always positive and less than one.

We can also have the equations for magnification by combining the lens equation with the formula for magnification as,

$$m = \frac{h_2}{h_1} = \frac{f}{f+u} \quad (\text{or}) \quad m = \frac{h_2}{h_1} = \frac{f-v}{f} \quad (6.73)$$

EXAMPLE 6.14

A biconvex lens has radii of curvature 20 cm and 15 cm each. The refractive index of the material of the lens is 1.5. What is its focal length? Will the focal length change if the lens is flipped by the side?

Solution

For a biconvex lens, radius of curvature of the first surface is positive and that of the second surface is negative side as shown in the figure.

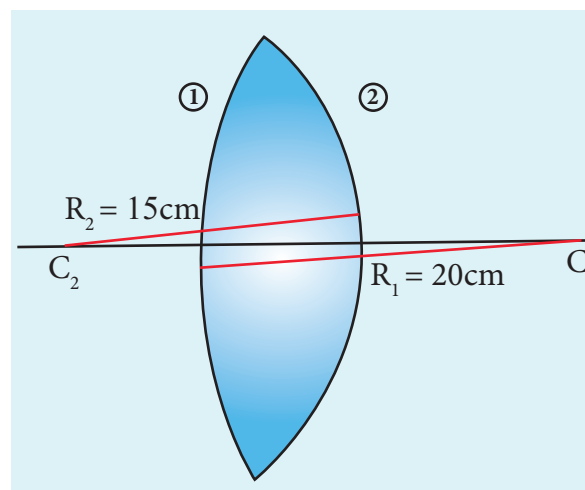

Given, $n = 1.5$, $R_1 = 20$ cm and $R_2 = -15$ cm

Lens maker's formula, $\frac{1}{f} = (n-1) \left(\frac{1}{R_1} - \frac{1}{R_2} \right)$

Substituting the values,

$$\frac{1}{f} = (1.5-1) \left(\frac{1}{20} - \frac{1}{-15} \right)$$

$$\frac{1}{f} = (0.5) \left(\frac{1}{20} + \frac{1}{15} \right) = (0.5) \left(\frac{3+4}{60} \right) = \left(\frac{1}{2} \times \frac{7}{60} \right) = \frac{7}{120}$$

$$f = \frac{120}{7} = 17.14 \text{ cm}$$

As the focal length is positive the lens is a converging lens.

If the lens is flipped back to front,

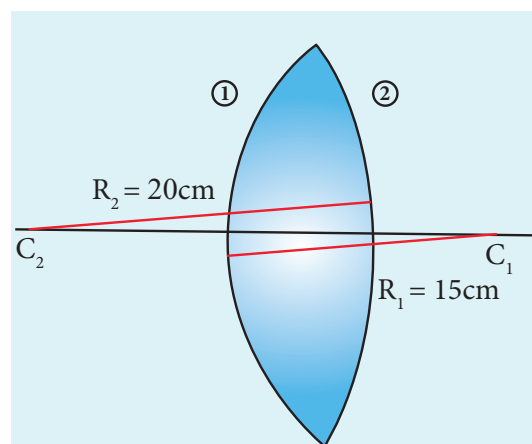

Now, $R_1 = 15 \text{ cm}$ and $R_2 = -20 \text{ cm}$, $n = 1.5$

Substituting the values,

$$\frac{1}{f} = (1.5 - 1) \left(\frac{1}{15} - \frac{1}{-20} \right)$$

$$\frac{1}{f} = (1.5 - 1) \left(\frac{1}{15} + \frac{1}{20} \right)$$

This will also result in, $f = 17.14 \text{ cm}$

Thus, it is concluded that the focal length of the lens will not change if it is flipped side wise. This is true for any lens. Students can verify this for any lens.

EXAMPLE 6.15

Determine the focal length of the lens made up of a material of refractive index 1.52 as shown in the diagram. (Points C_1 and C_2 are the centers of curvature of the first and second surface.)

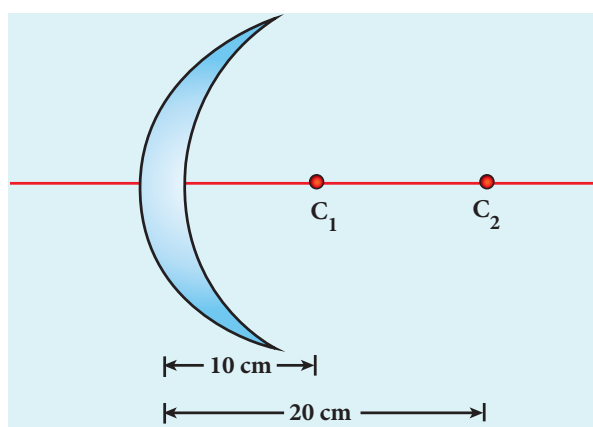

Solution

This lens is called convexo-concave lens

Given, $n = 1.52$, $R_1 = 10 \text{ cm}$ and $R_2 = 20 \text{ cm}$

Lens makers formula, $\frac{1}{f} = (n - 1) \left(\frac{1}{R_1} - \frac{1}{R_2} \right)$

Substituting the values,

$$\frac{1}{f} = (1.52 - 1) \left(\frac{1}{10} - \frac{1}{20} \right)$$

$$\frac{1}{f} = (0.52) \left(\frac{2-1}{20} \right) = (0.52) \left(\frac{1}{20} \right) = \frac{0.52}{20}$$

$$f = \frac{20}{0.52} = 38.46 \text{ cm}$$

As the focal length is positive, the lens is a converging lens.

6.6.5 Power of a lens

Power of lens is the measurement of deviating strength of a lens i.e. when a ray is incident on a lens then the degree with which the lens deviates the ray is determined by the power of the lens. Power of the lens is inversely proportional to focal length i.e. greater the power of lens, greater will be the deviation of ray and smaller will be the focal length. In Figure 6.36, the lens (b) has greater deviating strength than that of (a). As (b) has greater deviating strength, its focal length is less and vice versa.

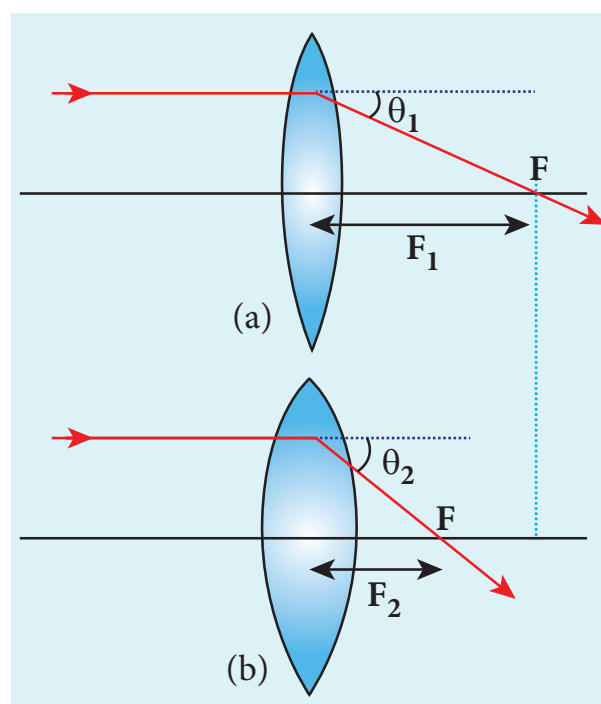

Figure 6.36 Power of lens

In other words, the *power* of a lens is a measure of the degree of convergence or

divergence of light falling on it. The power of a lens P is defined as the reciprocal of its focal length.

$$P = \frac{1}{f} \quad (6.74)$$

The unit of power is diopter D . $1 D = 1 \text{ m}^{-1}$. Power is positive for converging lens and negative for diverging lens.

From the lens makers formula, equation (6.68), the equation for power can be written as,

$$P = \frac{1}{f} = (n-1) \left(\frac{1}{R_1} - \frac{1}{R_2} \right) \quad (6.75)$$

The outcome of this equation of power is that larger the value of refractive index, greater is the power of lens and vice versa. Also for lenses with small radius of curvature (bulky) the power is large and for lenses with large the radius of curvature (skinny), the power is small.

EXAMPLE 6.16

If the focal length is 150 cm for a glass lens, what is the power of the lens?

Solution

Given, focal length, $f = 150 \text{ cm}$ (or) $f = 1.5 \text{ m}$

Equation for power of lens is, $P = \frac{1}{f}$

Substituting the values,

$$P = \frac{1}{1.5} = 0.67 \text{ diopter}$$

As the power is positive, it is a converging lens.

6.6.6 Focal length of lenses in contact

Let us consider two lenses ① and ② of focal length f_1 and f_2 are placed coaxially in

contact with each other so that they have a common principal axis. For an object placed at O beyond the focus of the first lens ① on the principal axis, an image is formed by it at I' . This image I' acts as an object for the second lens ② and the final image is formed at I as shown in Figure. 6.37. As these two lenses are thin, the measurements are done with respect to the common optical centre P in the middle of the two lenses.

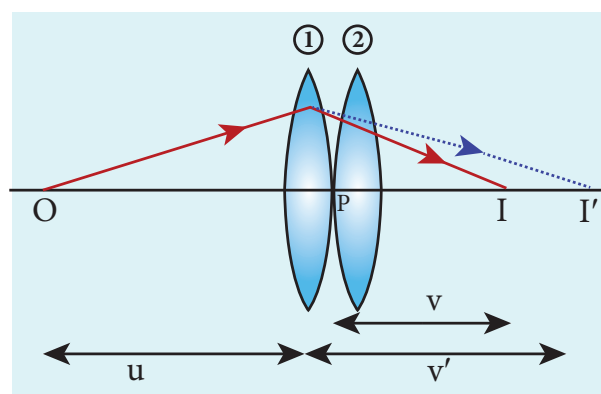

Figure. 6.37 Lenses in contact

Let, PO be object distance u and PI' be the image distance (v') for the first lens ① and object distance for the second lens ② and $PI = v$ be the image distance for the second lens ②.

Writing the lens equation for first lens ①,

$$\frac{1}{v'} - \frac{1}{u} = \frac{1}{f_1} \quad (6.76)$$

Writing the lens equation for second lens ②,

$$\frac{1}{v} - \frac{1}{v'} = \frac{1}{f_2} \quad (6.77)$$

Adding the above two equations (6.76) and (6.77),

$$\frac{1}{v} - \frac{1}{u} = \frac{1}{f_1} + \frac{1}{f_2} \quad (6.78)$$

If the combination acts as a single lens of focal length f so that for an object at the position O it forms the image at I then,

$$\frac{1}{v} - \frac{1}{u} = \frac{1}{F} \quad (6.79)$$

Comparing equations (6.78) and (6.79) we can write,

$$\frac{1}{F} = \frac{1}{f_1} + \frac{1}{f_2} \quad (6.80)$$

The above equation can be extended for any number of lenses in contact as,

$$\frac{1}{F} = \frac{1}{f_1} + \frac{1}{f_2} + \frac{1}{f_3} + \frac{1}{f_4} + \dots \quad (6.81)$$

The above equation can be written as power of the lenses as,

$$P = P_1 + P_2 + P_3 + P_4 + \dots \quad (6.82)$$

Where, P is the net power of the lens combination of lenses in contact. One should note that the sum in equation (6.82) is an algebraic sum. The powers of individual lenses may be positive (for convex lenses) or negative (for concave lenses). Combination of lenses helps to obtain diverging or converging lenses of desired magnification. Also, combination of lenses enhances the sharpness of the images. As the image formed by the first lens becomes the object for the second and so on, the total magnification m of the combination is a product of magnification of individual lenses. We can write, $m = m_1 \times m_2 \times m_3 \dots$ (without proof).

EXAMPLE 6.17

What is the focal length of the combination if a lens of focal length -70 cm is brought in contact with a lens of focal length 150 cm? What is the power of the combination?

Solution

Given, focal length of first lens, $f_1 = -70$ cm, focal length of second lens, $f_2 = 150$ cm.

Equation for focal length of lenses in contact, $\frac{1}{F} = \frac{1}{f_1} + \frac{1}{f_2}$

Substituting the values,

$$\frac{1}{F} = \frac{1}{-70} + \frac{1}{150} = -\frac{1}{70} + \frac{1}{150}$$

$$\frac{1}{F} = \frac{-150 + 70}{70 \times 150} = \frac{-80}{70 \times 150} = -\frac{80}{10500}$$

$$F = \frac{-10500}{8} = -1312.5 \text{ cm}$$

As the focal length is negative, the combination of two lenses is a diverging system of lenses.

The power of combination is,

$$P = \frac{1}{F} = \frac{1}{-1.3125 \text{ m}} = -0.76 \text{ diopter}$$

6.6.7 Focal length of lenses in out of contact

When two thin lenses are separated by a distance d common optical center cannot be chosen for them. Hence, they cannot be treated as a single thin lens. Actually, such a combination should be treated as a thick lens for which the theory is more involved (beyond the scope of present study). However, as a special case, only when the object is placed at infinity, the combination can be replaced by a single thin lens. The focal length and position of the equivalent lens can be derived by considering the concept of angle of deviation.

Let O be a point object on the principal axis of a lens as shown in Figure 6.38. OA is the incident ray on the lens at a point A at a height h above the optical centre. The ray is deviated through an angle δ and forms the image at I on the principal axis.

The incident and refracted rays subtend the angles, $\angle AOP = \alpha$ and $\angle AIP = \beta$ with the principal axis respectively.

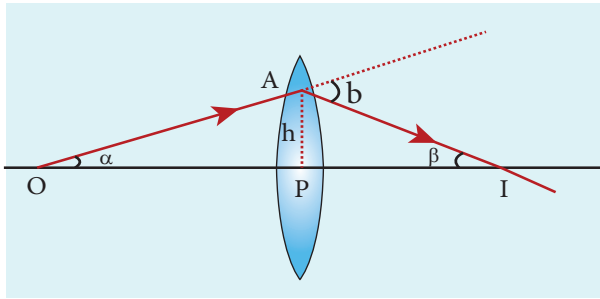

Figure 6.38 Angle of deviation in lens

In the triangle ΔOAI , the angle of deviation δ can be written as,

$$\delta = \alpha + \beta \quad (6.83)$$

If the height h is small as compared to PO and PI , the angles α , β and δ are also small. Then,

$$\alpha \approx \tan \alpha = \frac{PA}{PO}; \text{ and } \beta \approx \tan \beta = \frac{PA}{PI} \quad (6.84)$$

$$\text{Then, } \delta = \frac{PA}{PO} + \frac{PA}{PI} \quad (6.85)$$

Here, $PA = h$, $PO = -u$ and $PI = v$

$$\delta = \frac{h}{-u} + \frac{h}{v} = h \left(\frac{1}{-u} + \frac{1}{v} \right) \quad (6.86)$$

After rearranging

$$\delta = h \left(\frac{1}{v} - \frac{1}{u} \right) = \frac{h}{f}$$

$$\delta = \frac{h}{f} \quad (6.87)$$

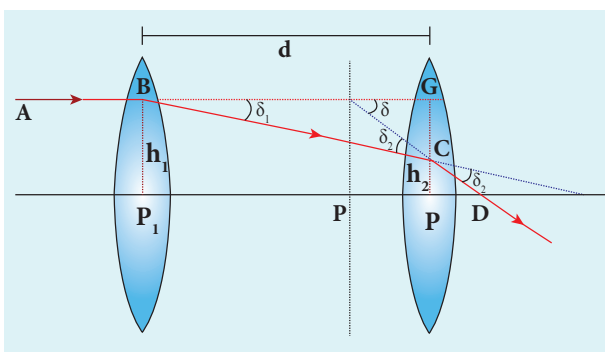

Figure 6.39 Lens in out of contact

The above equation tells that the angle of deviation is the ratio of height to the focal length. Now, the case of two lenses of focal length f_1 and f_2 arranged coaxially but separated by a distance d can be considered as shown in Figure 6.39.

For a parallel ray that falls on the arrangement, the two lenses produce deviations δ_1 and δ_2 respectively and The net deviation δ is.

$$\delta = \delta_1 + \delta_2 \quad (6.88)$$

From Equation (6.87),

$$\delta_1 = \frac{h_1}{f_1}; \delta_2 = \frac{h_2}{f_2} \text{ and } \delta = \frac{h_1}{f} \quad (6.89)$$

The equation (6.88) becomes,

$$\frac{h_1}{f} = \frac{h_1}{f_1} + \frac{h_2}{f_2} \quad (6.90)$$

From the geometry,

$$h_2 - h_1 = P_2G - P_2C = CG$$

$$h_2 - h_1 = BG \tan \delta_1 \approx BG \delta_1$$

$$h_2 - h_1 = d \frac{h_1}{f_1}$$

$$h_2 = h_1 + d \frac{h_1}{f_1} \quad (6.91)$$

Substituting the above equation in Equation (6.90)

$$\frac{h_1}{f} = \frac{h_1}{f_1} + \frac{h_1}{f_2} + \frac{h_1 d}{f_1 f_2}$$

On further simplification,

$$\frac{1}{f} = \frac{1}{f_1} + \frac{1}{f_2} + \frac{d}{f_1 f_2} \quad (6.92)$$

The above equation could be used to find the equivalent focal length. To find

the position of the equivalent lens, we can further write from the geometry,

$$PP_2 = EG = \frac{GC}{\tan \delta}$$

$$PP_2 = EG = \frac{h_1 - h_2}{\tan \delta} = \frac{h_1 - h_2}{\delta}$$

From equations (6.89) and (6.91)

$$h_2 - h_1 = d \frac{h_1}{f_1} \quad \text{and} \quad \delta = \frac{h_1}{f}$$

$$PP_2 = \left(d \frac{h_1}{f_1} \right) \times \left(\frac{f}{h_1} \right)$$

$$PP_2 = \left(d \frac{f}{f_1} \right) \quad (6.93)$$

POINTS TO PONDER



System of combination of lenses is commonly used in designing lenses for cameras, microscopes, telescopes and other optical instruments. They produce better magnification as well as sharpness of the images.

The above equation (6.93) is the position of the equivalent single lens from the second lens. Its position from the first lens is,

$$PP_1 = d - \left(d \frac{f}{f_1} \right)$$

$$PP_1 = d \left(1 - \frac{f}{f_1} \right) \quad (6.94)$$



The Equation (6.92), (6.93) and (6.94) hold good only for the special case of parallel incident rays or object at infinity. We cannot use these equations if the object is at a finite distance. For finite distance of the object, the image positions must be calculated separately using the lens equation for the two lenses.

EXAMPLE 6.18

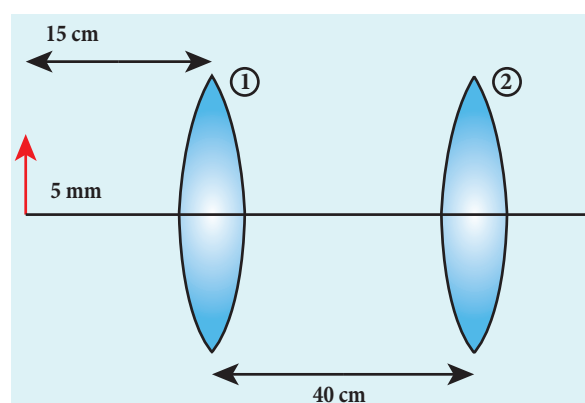

An object of 5 mm height is placed at a distance of 15 cm from a convex lens of focal length 10 cm. A second lens of focal length 5 cm is placed 40 cm from the first lens and 55 cm from the object. Find (a) the position of the final image, (b) its nature and (c) its size.

Solution

Given, $h_1 = 5 \text{ mm} = 0.5 \text{ cm}$, $u_1 = -15 \text{ cm}$, $f_1 = 10 \text{ cm}$, $f_2 = 5 \text{ cm}$, $d = 40 \text{ cm}$

For the first lens, the lens equation is,

$$\frac{1}{v_1} - \frac{1}{u_1} = \frac{1}{f_1}$$

Substituting the values,

$$\frac{1}{v_1} - \frac{1}{-15} = \frac{1}{10}; \quad \frac{1}{v_1} + \frac{1}{15} = \frac{1}{10}$$

$$\frac{1}{v_1} = \frac{1}{10} - \frac{1}{15} = \frac{15-10}{150} = \frac{5}{150} = \frac{1}{30}$$

$$v_1 = 30 \text{ cm}$$

First lens forms image 30 cm to the right of first lens.

Let us find the height of this image.

$$\text{Equation for magnification is, } m = \frac{h_2}{h_1} = \frac{v}{u}$$

$$\text{Substituting the values, } \frac{h_2}{0.5} = \frac{30}{-15}$$

$$h_2 = 0.5 \times \frac{30}{-15} = -1 \text{ cm}$$

As the height of the lens is negative, the image is inverted, real image.

Object is at 10 cm to the left of the second lens (40-30=10 cm). Hence, $u_2 = -10$ cm

For the second, the lens equation is,

$$\frac{1}{v_2} - \frac{1}{u_2} = \frac{1}{f_2}$$

Substituting the values,

$$\frac{1}{v_2} - \frac{1}{-10} = \frac{1}{5}; \quad \frac{1}{v_2} + \frac{1}{10} = \frac{1}{5}$$

$$\frac{1}{v_2} = \frac{1}{5} - \frac{1}{10} = \frac{10-5}{50} = \frac{5}{50} = \frac{1}{10}$$

$$v_2 = 10 \text{ cm}$$

The image is formed 10 cm to the right of the second lens.

Let us find the height of the final image. Assume, the final height of the image formed by the second lens is h_2' and the height of the object for the second lens

h_1' is the image height of the first lens,
 $h_1' = h_1$

$$\text{Equation for magnification is, } m = \frac{h_2'}{h_1'} = \frac{v_2}{u_2}$$

$$\text{Substituting the values, } \frac{h_2'}{-1} = \frac{10}{-10}$$

$$h_2' = (-1) \times \left(\frac{10}{-10} \right) = 1 \text{ cm} = 10 \text{ mm}$$

As the height of the image is positive, the image is erect, and it is real.

6.7

PRISM

A prism is a triangular block of glass or plastic. It is bounded by the three plane faces not parallel to each other. Its one face is grounded which is called base of the prism. The other two faces are polished which are called refracting faces of the prism. The angle between the two refracting faces is called angle of prism (or) refracting angle (or) apex angle of the prism represented as A as shown in Figure 6.40.

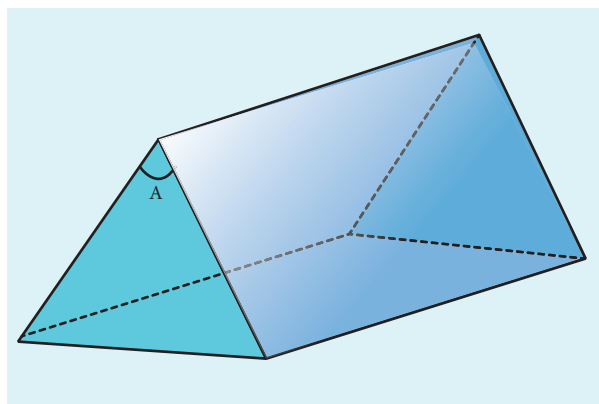

Figure 6.40 Prism

6.7.1 Angle of deviation produced by prism

Let light ray PQ is incident on one of the refracting faces of the prism as shown

in Figure 6.41. The angles of incidence and refraction at the first face AB are i_1 and r_1 . The path of the light inside the prism is QR . The angle of incidence and refraction at the second face AC is r_2 and i_2 respectively. RS is the ray emerging from the second face. Angle i_2 is also called angle of emergence. **The angle between the direction of the incident ray PQ and the emergent ray RS is called the angle of deviation d .** The two normals drawn at the point of incidence Q and emergence R are QN and RN . They meet at point N . The incident ray and the emergent ray meet at a point M .

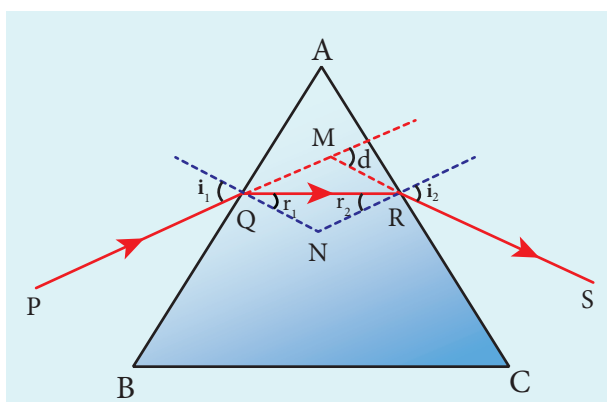

Figure 6.41 Refraction through prism

The deviation d_1 at the surface AB is,

$$\text{angle } \angle RQM = d_1 = i_1 - r_1 \quad (6.95)$$

The deviation d_2 at the surface AC is,

$$\text{angle } \angle QRM = d_2 = i_2 - r_2 \quad (6.96)$$

Total angle of deviation d produced is,

$$d = d_1 + d_2 \quad (6.97)$$

Substituting for d_1 and d_2 ,

$$d = (i_1 - r_1) + (i_2 - r_2)$$

After rearranging,

$$d = (i_1 - r_1) + (i_2 - r_2) \quad (6.98)$$

In the quadrilateral $AQNR$, two of the angles (at the vertices Q and R) are right angles. Therefore, the sum of the other angles of the quadrilateral is 180° .

$$\angle A + \angle QNR = 180^\circ \quad (6.99)$$

From the triangle $\triangle QNR$,

$$r_1 + r_2 + \angle QNR = 180^\circ \quad (6.100)$$

Comparing these two equations (6.99) and (6.100) we get,

$$r_1 + r_2 = A \quad (6.101)$$

Substituting this in equation (6.98) for angle of deviation,

$$d = i_1 + i_2 - A \quad (6.102)$$

Thus, the angle of deviation depends on the angle of incidence angle of emergence and the angle for the prism. For a given angle of incidence the angle of emergence is decided by the refractive index of the material of the prism. Hence, the angle of deviation depends on these following factors.

- (i) the angle of incidence
- (ii) the angle of the prism
- (iii) the material of the prism
- (iv) the wave length of the light

EXAMPLE 6.19

A monochromatic light is incident on an equilateral prism at an angle 30° and emerges at an angle of 75° . What is the angle of deviation produced by the prism?

Solution

Given, as the prism is equilateral,

$$A = 60^\circ; \quad i_1 = 30^\circ; \quad i_2 = 75^\circ$$

Equation for angle of deviation, $d = i_1 + i_2 - A$

Substituting the values, $d = 30^\circ + 75^\circ - 60^\circ = 45^\circ$

The angle of deviation produced is, $d = 45^\circ$

EXAMPLE 6.20

Light ray falls at normal incidence on the first face of an equilateral prism and emerges grazing the second face. What is the angle of deviation? What is the refractive index of the material of the prism?

Solution

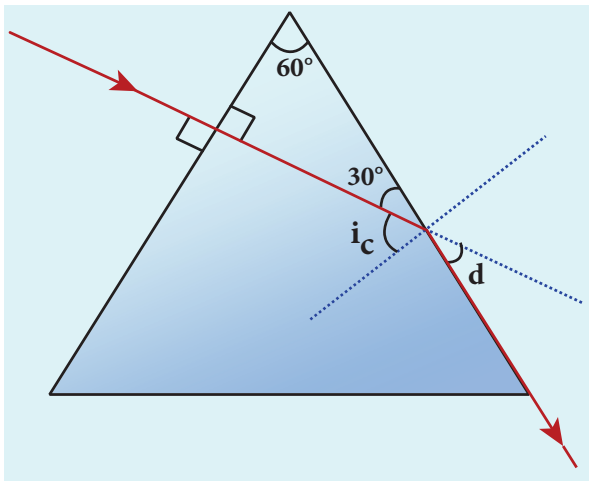

The given situation is shown in the figure.

Here, $A = 60^\circ$; $i_1 = 0^\circ$; $i_2 = 90^\circ$

Equation for angle of deviation,

$$d = i_1 + i_2 - A$$

Substituting the values,

$$d = 0^\circ + 90^\circ - 60^\circ = 30^\circ$$

The angle of deviation produced is, $d = 30^\circ$

The light inside the prism must be falling on the second face at critical angle as it grazes the boundary.

Equation for critical angle is, $\sin i_c = \frac{1}{n}$

$$n = \frac{1}{\sin i_c}; \quad n = \frac{1}{\sin 30^\circ} = \frac{1}{1/2} = 2$$

The refractive index of the material of the prism is, $n = 2$

6.7.2 Angle of minimum deviation

A graph plotted between the angle of incidence and angle of deviation is shown in Figure 6.42. One could observe that the angle of deviation decreases with increase in angle of incidence and reaches a minimum value and then continues to increase.

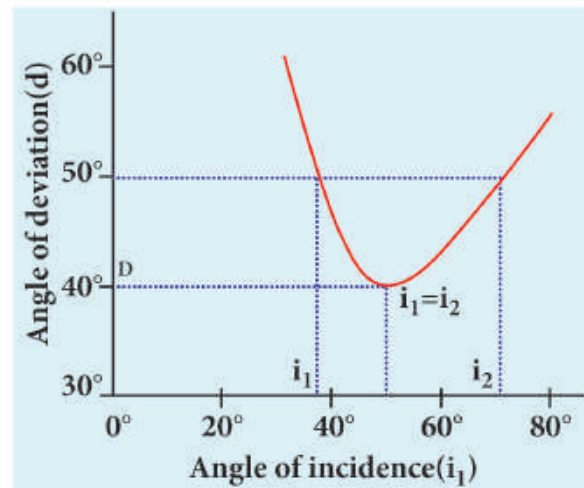

Figure 6.42 Graph between i and d

The minimum value of angle of deviation is called angle of *minimum deviation* D . At minimum deviation,

- the angle of incidence is equal to the angle of emergence, $i_1 = i_2$.
- the angle of refraction at the face one and face two are equal, $r_1 = r_2$.

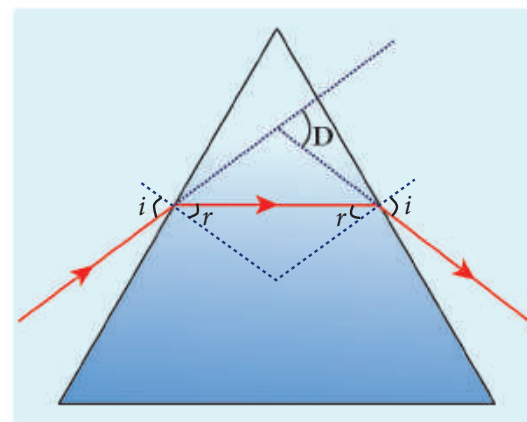

Figure 6.43 Angle of minimum deviation

- (c) the incident ray and emergent ray are symmetrical with respect to the prism.
 (d) the refracted ray inside the prism is parallel to its base of the prism.

The case of angle of minimum deviation is shown in Figure 6.43.

6.7.3 Refractive index of the material of the prism

At minimum deviation, $i_1 = i_2 = i$ and $r_1 = r_2 = r$

Now, the equation (6.102) becomes,

$$D = i_1 + i_2 - A = 2i - A \quad (\text{or}) \quad i = \frac{(A + D)}{2}$$

The equation (6.101) becomes,

$$r_1 + r_2 = A \Rightarrow 2r = A \quad (\text{or}) \quad r = \frac{A}{2}$$

Substituting i and r in Snell's law,

$$n = \frac{\sin i}{\sin r}$$

$$n = \frac{\sin\left(\frac{A + D}{2}\right)}{\sin\left(\frac{A}{2}\right)} \quad (6.103)$$

The above equation is used to find the refractive index of the material of the prism. The angles A and D can be measured experimentally.

EXAMPLE 6.21

The angle of minimum deviation for a prism is 37° . If the angle of prism is 60° , find the refractive index of the material of the prism.

Solution

Given, $A = 60^\circ$; $D = 37^\circ$

Equation for refractive index is,

$$n = \frac{\sin\left(\frac{A + D}{2}\right)}{\sin\left(\frac{A}{2}\right)}$$

Substituting the values,

$$n = \frac{\sin\left(\frac{60^\circ + 37^\circ}{2}\right)}{\sin\left(\frac{60^\circ}{2}\right)} = \frac{\sin(48.5^\circ)}{\sin(30^\circ)} = \frac{0.75}{0.5} = 1.5$$

The refractive index of the material of the prism is, $n = 1.5$

6.7.4 Dispersion of white light through prism

So far the angle of deviation produced by a prism is discussed for monochromatic light (i.e. light of single colour). When white light enter in to a prism, the effect called *dispersion* takes place. **Dispersion is splitting of white light into its constituent colours. This band of colours of light is called its spectrum.** When a narrow beam of parallel rays of white light is incident on the face of a prism and the refracted beam is received on a white screen, a band of colours is obtained in the order, recollected by the word: VIBGYOR i.e., Violet, Indigo, Blue, Green, Yellow, Orange and Red. Violet is the most deviated and red is the least deviated colour as shown in Figure 6.44.

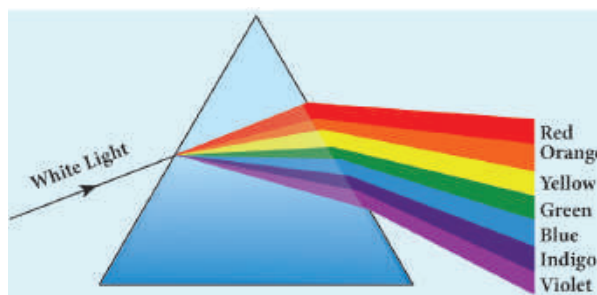

Figure 6.44 Dispersion of white light in to its constituent colours

The colours obtained in a spectrum depend on the nature of the source of the light used. Each colour of light is associated with a definite wavelength. Red light is at the longer wavelength end (700 nm) while the violet light is at the shorter wavelength end (400 nm). Therefore the violet ray travels with a smaller velocity in glass prism than red ray.

POINTS TO PONDER

Sir Isaac Newton has demonstrated through a classic experiment to produce white light when all the colours of VIBGYOR are recombined. He used a prism to produce dispersion and made all the colours to incident on another inverted prism to combine all the colours to get white light as shown in figure.



Dispersion takes place because light of different wave lengths travel with different speeds inside the prism. In other words, the refractive index of the material of the prism is different for different colours. For violet, the refractive index is high and for red the refractive index is the low. In Vacuum, all the colours travel with the same speed. The refractive index of two different glasses for different colours is shown in Table 6.4.

The speed of light is independent of wavelength in vacuum. Therefore, vacuum is a non-dispersive medium in which all colours travel with the same speed.

Table 6.4 Refractive indices for different wavelengths

Colour	Wavelength (nm)	Crown glass	Flint glass
Violet	396.9	1.533	1.663
Blue	486.1	1.523	1.639
Yellow	589.3	1.517	1.627
Red	656.3	1.515	1.622

6.7.5 Dispersive Power

Consider a beam of white light passes through a prism; it gets dispersed into its constituent colours as shown in Figure 6.45. Let δ_V , δ_R are the angles of deviation for violet and red light. Let n_V and n_R are the refractive indices for the violet and red light respectively.

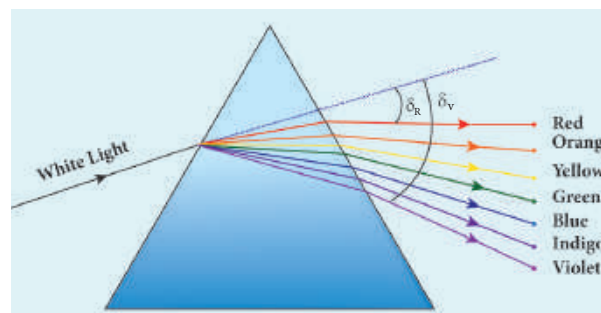

Figure 6.45 Angle of deviation for different colours

The refractive index of the material of a prism is given by the equation (6.103),

$$n = \frac{\sin\left(\frac{A+D}{2}\right)}{\sin\left(\frac{A}{2}\right)}$$

Here A is the angle of the prism and D is the angle of minimum deviation. If the angle of prism is small of the order of 10° , the prism is said to be a small angle prism. When rays of light pass through such prisms, the angle of deviation also becomes small. If A be the angle of a small angle prism and

δ the angle of deviation then the prism formula becomes.

$$n = \frac{\sin\left(\frac{A + \delta}{2}\right)}{\sin\left(\frac{A}{2}\right)} \quad (6.104)$$

For small angles of A and δ ,

$$\sin\left(\frac{A + \delta}{2}\right) \approx \left(\frac{A + \delta}{2}\right) \quad (6.105)$$

$$\sin\left(\frac{A}{2}\right) \approx \left(\frac{A}{2}\right) \quad (6.106)$$

$$\therefore n = \frac{\left(\frac{A + \delta}{2}\right)}{\left(\frac{A}{2}\right)} = \frac{A + \delta}{A} = 1 + \frac{\delta}{A}$$

Further simplifying, $\frac{\delta}{A} = n - 1$

$$\delta = (n - 1)A \quad (6.107)$$

When white light enters the prism, the deviation is different for different colours. Thus, the refractive index is also different for different colours.

$$\text{For Violet light, } \delta_V = (n_V - 1)A \quad (6.108)$$

$$\text{For Red light, } \delta_R = (n_R - 1)A \quad (6.109)$$

As, angle of deviation for violet colour δ_V is greater than angle of deviation for red colour δ_R , the refractive index for violet colour n_V is greater than the refractive index for red colour n_R .

Subtracting δ_V from δ_R we get,

$$\delta_V - \delta_R = (n_V - n_R)A \quad (6.110)$$

The term $(\delta_V - \delta_R)$ is the angular separation between the two extreme colours (violet and red) in the spectrum

is called the **angular dispersion**. Clearly, the angular dispersion produced by a prism depends upon.

- (i) Angle of the prism
- (ii) Nature of the material of the prism.

If we take δ is the angle of deviation for any middle ray (green or yellow) and n the corresponding refractive index. Then,

$$\delta = (n - 1)A \quad (6.111)$$

Dispersive power (ω) is the ability of the material of the prism to cause dispersion. It is defined as the ratio of the angular dispersion for the extreme colours to the deviation for any mean colour.

Dispersive power (ω),

$$\omega = \frac{\text{angular dispersion}}{\text{mean deviation}} = \frac{\delta_V - \delta_R}{\delta} \quad (6.112)$$

Substituting for $(\delta_V - \delta_R)$ and (δ) ,

$$\omega = \frac{(n_V - n_R)}{(n - 1)} \quad (6.113)$$

Dispersive power is a dimensionless quantity. It has no unit. Dispersive power is always positive. The dispersive power of a prism depends only on the nature of material of the prism and it is independent of the angle of the prism.

EXAMPLE 6.22

Find the dispersive power of flint glass if the refractive indices of flint glass for red, green and violet light are 1.613, 1.620 and 1.632 respectively.

Solution

Given, $n_V = 1.632$; $n_R = 1.613$; $n_G = 1.620$

Equation for dispersive power is,

$$\omega = \frac{(n_V - n_R)}{(n_G - 1)}$$



Substituting the values,

$$\omega = \frac{1.632 - 1.613}{1.620 - 1} = \frac{0.019}{0.620} = 0.0306$$

The dispersive power of flint glass is,
 $\omega = 0.0306$

6.7.6 Scattering of sunlight

When sunlight enters the atmosphere of the earth, the atmospheric particles present in the atmosphere change the direction of the light. This process is known as scattering of light.



If the scattering of light is by atoms and molecules which have size a very less than that of the wave length λ of light $a \ll \lambda$, the

scattering is called Rayleigh's scattering. The intensity of Rayleigh's scattering is inversely proportional to fourth power of wavelength.

$$I \propto \frac{1}{\lambda^4} \quad (6.114)$$

According to equation 6.114, violet colour which has the shortest wavelength gets much scattered during day time. The next scattered colour is blue. As our eyes are more sensitive to blue colour than violet colour the sky appears blue during day time as shown in Figure 6.46(a). But, during sunrise and sunset, the light from sun travels a greater distance through the atmosphere. Hence, the blue light which has shorter wavelength is scattered away and the less-scattered red light of longer wavelength manages to reach



Rainbow is an example of dispersion of sunlight through droplets of water during rainy days. Rainbow is observed during a rainfall or after the rainfall or when we look at a water fountain provided the sun is at the back of the observer. When sunlight falls on the water drop suspended in air, it splits (or dispersed) into its constituent seven colours. Thus, water drop suspended in air behaves as a glass prism. Primary rainbow is formed when light entering the drop undergoes one total internal reflection inside the drop before coming out from the drop as shown in figure. The angle of view for violet to red in primary rainbow is 40° to 42° . A secondary rainbow appears outside of a primary rainbow and develops when light entering a raindrop undergoes two internal reflections. The angle of view for red to violet in a secondary rainbow is, 52° to 54° .

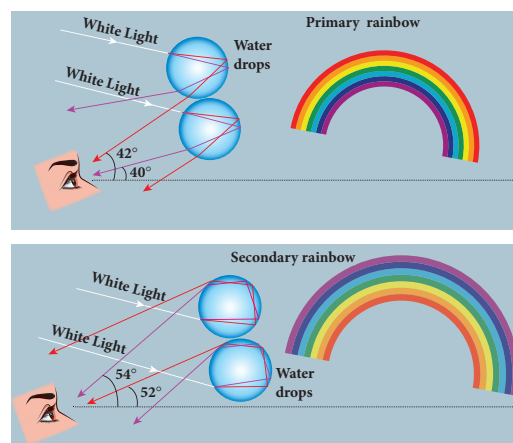

our eye. This is the reason for the reddish appearance of sky during sunrise and sunset as shown in Figure 6.46(b).

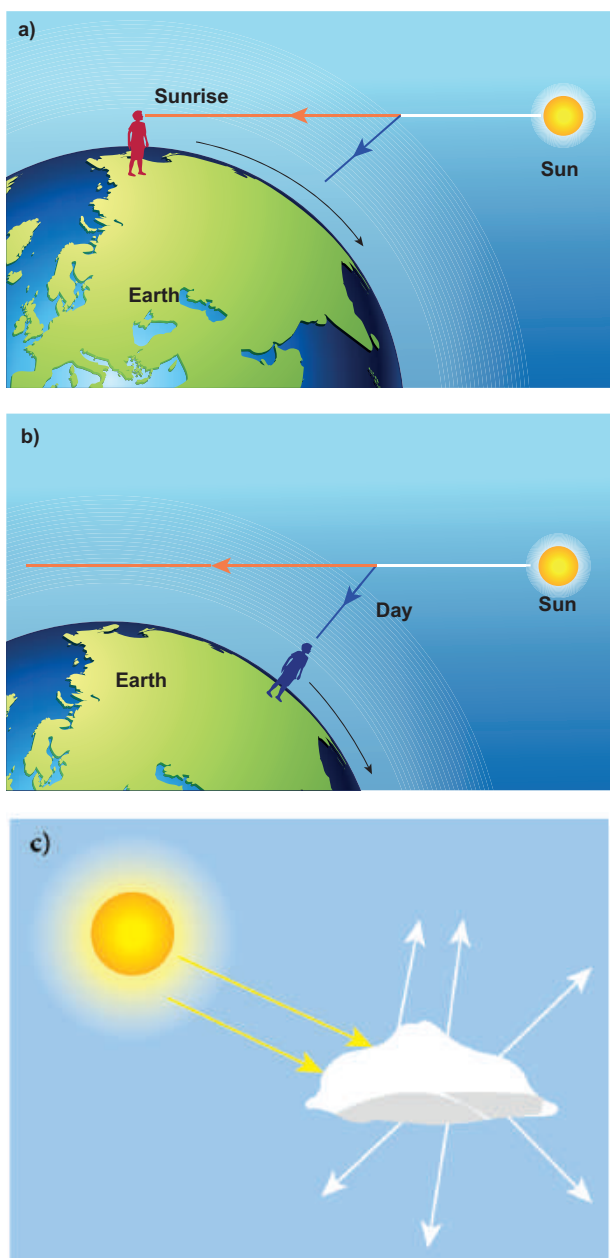

Figure 6.46. Scattering of different types

If light is scattered by large particles like dust and water droplets present in the atmosphere which have size a greater than the wavelength λ of light, $a \gg \lambda$, the intensity of scattering is equal for all the wavelengths. It is happening in clouds which contains large amount of dust and water droplets. Thus, in clouds all the colours get equally scattered irrespective

of wavelength. This is the reason for the whitish appearance of cloud as shown in Figure 6.46(c). But, the rain clouds appear dark because of the condensation of water droplets on dust particles that makes the cloud become opaque.

If earth has no atmosphere there would not have been any scattering and the sky would appear dark. That is why sky appears dark for the astronauts who could see the sky from above the atmosphere.

6.8 THEORIES ON LIGHT

Light is a form of energy that is transferred from one place to another. A glance at the evolution of various theories of light put forward by scientists will give not only an over view of the nature of light but also its propagation and some phenomenon demonstrated by it.

6.8.1 Corpuscular theory

Sir Isaac Newton (1672) gave the corpuscular theory of light which was also suggested earlier by Descartes (1637) to explain the laws of reflection and refraction. According this theory, light is emitted as tiny, massless (negligibly small mass) and perfectly elastic particles called corpuscles. As the corpuscles are very small, the source of light does not suffer appreciable loss of mass even if it emits light for a long time. On account of high speed, they are unaffected by the force of gravity and their path is a straight line in a medium of uniform refractive index. The energy of light is the kinetic energy of these corpuscles. When these corpuscles impinge on the retina of the eye, the vision is produced. The

different size of the corpuscles is the reason for different colours of light. When the corpuscles approach a surface between two media, they are either attracted or repelled. The reflection of light is due to the repulsion of the corpuscles by the medium and refraction of light is due to the attraction of the corpuscles by the medium.

This theory could not explain the reason why the speed of light is lesser in denser medium than in rarer medium and also the phenomena like interference, diffraction and polarisation.

6.8.2 Wave theory

Christian Huygens (1678) proposed the wave theory to explain the propagation of light through a medium. According to him, light is a disturbance from a source that travels as longitudinal mechanical waves through the ether medium that was presumed to pervade all space as mechanical wave requires medium for its propagation. The wave theory could successfully explain phenomena of reflection, refraction, interference and diffraction of light.

Later, the existence of ether in all space was proved to be wrong. Hence, this theory could not explain the propagation of light through vacuum. The phenomenon of polarisation could not be explained by this theory as it is the property of only transverse waves.

6.8.3 Electromagnetic wave theory

Maxwell (1864) proved that light is an electromagnetic wave which is transverse in nature carrying electromagnetic energy. He could also show that no medium is necessary for the propagation of electromagnetic

waves. All the phenomenon of light could be successfully explained by this theory.

Nevertheless, the interaction phenomenon of light with matter like photoelectric effect, Compton effect could not be explained by this theory.

6.8.4 Quantum theory

Albert Einstein (1905), endorsing the views of Max Planck (1900), was able to explain photoelectric effect (discussed in Unit 7) in which light interacts with matter as photons to eject the electrons. A *photon* is a discrete packet of energy. Each photon has energy E of,

$$E = h\nu \quad (6.115)$$

Where, h is Planck's constant ($h = 6.625 \times 10^{-34}$ J s) and ν is frequency of electromagnetic wave.

As light has both wave as well as particle nature it is said to have dual nature. Thus, it is concluded that light propagates as a wave and interacts with matter as a particle.

6.9 WAVE NATURE OF LIGHT

Light is a transverse, electromagnetic wave. The wave nature of light was first illustrated through experiments on interference and diffraction. Like all electromagnetic waves, light can travel through vacuum. The transverse nature of light is demonstrated in polarization.

6.9.1 Wave optics

Wave optics deals with the wave characteristics of light. With the help of

wave optics, we are going to learn in details the phenomena of interference, diffraction and polarization. Even the law of reflection and refraction are proved only with the help of wave optics. Though light propagates as a wave, its direction of propagation is still represented as a ray.

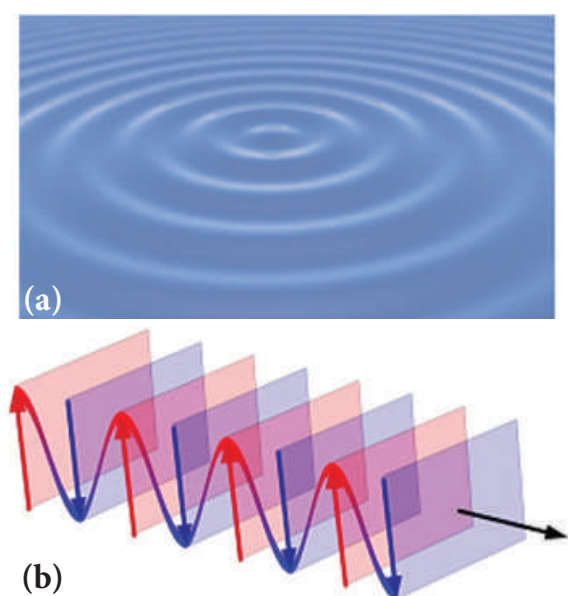

Figure 6.47 (a) Ripples on water surface
(b) Wavefront and ray

An example for wave propagation is the spreading of circular ripples on the surface of still water from a point at which a stone is dropped. The molecules or particles of water are moving only up and down (oscillate) when a ripple passes out that part. All these particles on the circular ripple are in the same phase of vibration as they are all at the same distance from the center. The ripple represents a wavefront as shown in Figure 6.47(a). A **wavefront is the locus of points which are in the same state or phase of vibration**. When a wave propagates it is treated as the propagation of wavefront. The wavefront is always perpendicular to the direction of the propagation of the wave. As the direction of ray is in the direction of propagation of the wave, the wavefront is always perpendicular to the ray as shown in Figure 6.47(b).

The shape of a wavefront observed at a point depends on the shape of the source and also the distance at which the source is located. A point source located at a finite distance gives spherical wavefronts. An extended (or) line source at finite distance gives cylindrical wavefronts. The plane wavefronts are received from any source that is located at infinity as shown in Figure 6.48.

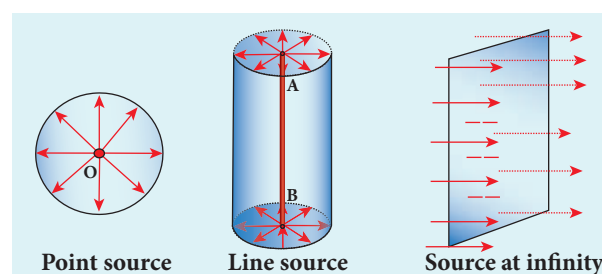

Figure 6.48 Wavefronts

6.9.2 Huygens' Principle

Huygens principle is a geometrical construction which gives the shape of the wavefront at any time if we know its shape at $t = 0$. **According to Huygens principle, each point of the wavefront is the source of secondary wavelets emanating from these points spreading out in all directions with the speed of the wave. These are called as secondary wavelets.** The common tangent, in other words the envelope to all these wavelets gives the position and shape of the new wavefront at a later time. Thus, Huygens' principle explains the propagation of a wavefront.

The propagation of a spherical and plane wavefront is explained in using Huygens' principle. Let, AB be the wavefront at a time, $t = 0$. According to Huygens' principle, every point on AB acts as a source of secondary wavelet which travels with the speed of the wave (speed of light c). To find the position of the wavefront after a time t , circles of

radius equal to ct are drawn with points $P, Q, R \dots$ etc., as centers on AB . The tangent or forward envelope $A'B'$ of the small circles is the new wavefront at that instant. The wavefront $A'B'$ will be a spherical wavefront from a point object which is at a finite distance as shown in Figure 49(a) and it is a plane wavefront if the source of light is at a large distance (infinity) as shown in Figure 6.49(b).

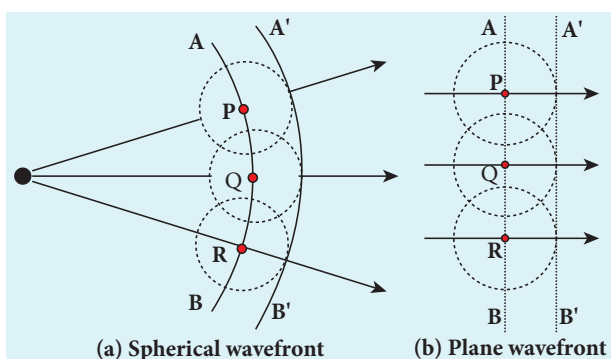

Figure 6.49 Huygens' Principle

There is one shortcoming in the above Huygens' construction for propagation of a wavefront. It could not explain the absence of backwave which also arises in the above construction. According to electromagnetic wave theory, the backwave is ruled out inherently. However, Huygens' construction diagrammatically explains the propagation of the wavefront.

6.9.3 Proof for laws of reflection using Huygens' Principle

Let us consider a parallel beam of light, incident on a reflecting plane surface such as a plane mirror XY as shown in Figure 6.50. The incident wavefront is AB and the reflected wavefront is $A'B'$ in the same medium. These wavefronts are perpendicular to the incident rays L, M and reflected rays L', M' respectively. By

the time point A of the incident wavefront touches the reflecting surface, the point B is yet to travel a distance BB' to touch the reflecting surface at B' . When the point B falls on the reflecting surface at B' , the point A would have reached A' . This is applicable to all the points on the wavefront. Thus, the reflected wavefront $A'B'$ emanates as a plane wavefront. The two normals N and N' are considered at the points where the rays L and M fall on the reflecting surface. As reflection happens in the same medium, the speed of light is same before and after the reflection. Hence, the time taken for the ray to travel from B to B' is the same as the time taken for the ray to travel from A to A' . Thus, the distance BB' is equal to the distance AA' ; ($AA' = BB'$).

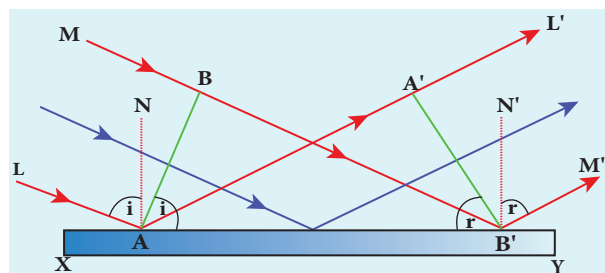

Figure 6.50 Laws of reflection

(i) The incident rays, the reflected rays and the normal are in the same plane.

(ii) Angle of incidence,
 $\angle i = \angle NAL = 90^\circ - \angle NAB = \angle BAB'$

Angle of reflection,
 $\angle r = \angle N'B'M' = 90^\circ - \angle N'B'A' = \angle A'B'A$

For the two right angle triangles, $\triangle ABB'$ and $\triangle B'A'A$, the right angles, $\angle B$ and $\angle A'$ are equal, ($\angle B$ and $\angle A' = 90^\circ$); the two sides, AA' and BB' are equal, ($AA' = BB'$); the side AB' is the common. Thus, the two triangles are congruent. As per the property of congruency, the two angles, $\angle BAB'$ and $\angle A'B'A$ must also be equal.

$$i = r \quad (6.1)$$

Hence, the laws of reflection are proved.

6.9.4 Proof for laws of refraction using Huygens' Principle

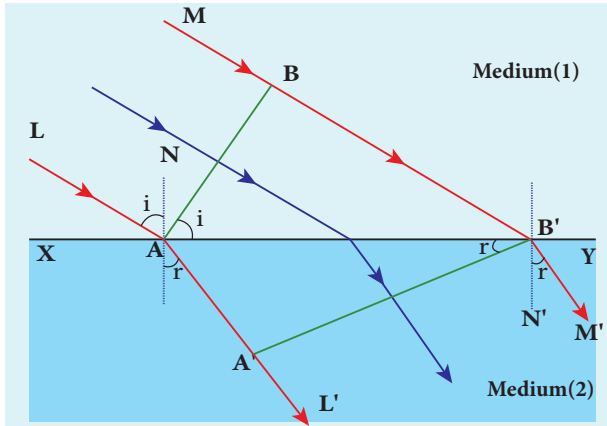

Figure 6.51 Law of refraction

Let us consider a parallel beam of light is incident on a refracting plane surface XY such as a glass surface as shown in Figure 6.51. The incident wavefront AB is in rarer medium (1) and the refracted wavefront $A'B'$ is in denser medium (2). These wavefronts are perpendicular to the incident rays L, M and refracted rays L', M' respectively. By the time the point A of the incident wavefront touches the refracting surface, the point B is yet to travel a distance BB' to touch the refracting surface at B' . When the point B falls on the refracting surface at B' , the point A would have reached A' in the other medium. This is applicable to all the points on the wavefront. Thus, the refracted wavefront $A'B'$ emanates as a plane wavefront. The two normals N and N' are considered at the points where the rays L and M fall on the refracting surface. As refraction happens from rarer medium (1) to denser medium (2), the speed of light is

v_1 and v_2 before and after refraction and v_1 is greater than v_2 ($v_1 > v_2$). But, the time taken t for the ray to travel from B to B' is the same as the time taken for the ray to travel from A to A' .

$$t = \frac{BB'}{v_1} = \frac{AA'}{v_2} \quad (\text{or}) \quad \frac{BB'}{AA'} = \frac{v_1}{v_2}$$

(i) The incident rays, the refracted rays and the normal are in the same plane.

(ii) Angle of incidence,

$$i = \angle NAL = 90^\circ - \angle NAB = \angle BAB'$$

Angle of refraction,

$$r = \angle N'B'M' = 90^\circ - \angle N'B'A' = \angle A'B'A$$

For the two right angle triangles $\triangle ABB'$ and $\triangle B'A'A$,

$$\frac{\sin i}{\sin r} = \frac{BB'/AB'}{AA'/AB'} = \frac{BB'}{AA'} = \frac{v_1}{v_2} = \frac{c/v_2}{c/v_1}$$

Here, c is speed of light in vacuum. The ratio c/v is the constant, called refractive index of the medium. The refractive index of medium (1) is, $c/v_1 = n_1$ and that of medium (2) is, $c/v_2 = n_2$.

$$\frac{\sin i}{\sin r} = \frac{n_2}{n_1} \quad (6.18)$$

In product form,

$$n_1 \sin i = n_2 \sin r \quad (6.19)$$

Hence, the laws of refraction are proved.

In the same way the laws of refraction can also be proved for wavefront travelling from denser to rarer medium.

Light travels with greater speed in rarer medium and lesser speed in denser medium. Hence, the wavelength of the light is longer in rarer medium and shorter in denser medium.

$$\frac{\lambda_1}{\lambda_2} = \frac{n_2}{n_1} \quad (6.116)$$

Note

If light of a particular frequency travels through different media, then, its frequency remains unchanged in all the media. Only the wavelength changes according to speed of light in that medium.

EXAMPLE 6.23

The wavelength of light from sodium source in vacuum is 5893\AA . What are its (a) wavelength, (b) speed and (c) frequency when this light travels in water which has a refractive index of 1.33.

Solution

The refractive index of vacuum, $n_1 = 1$

The wavelength in vacuum, $\lambda_1 = 5893\text{\AA}$.

The speed in vacuum, $c = 3 \times 10^8 \text{ m s}^{-1}$

The refractive index of water, $n_2 = 1.33$

The wavelength of light in water, λ_2

The speed of light in water, v_2

(a) The equation relating the wavelength and refractive index is,

$$\frac{\lambda_1}{\lambda_2} = \frac{n_2}{n_1}$$

Rewriting, $\lambda_2 = \frac{n_1}{n_2} \times \lambda_1$

Substituting the values,

$$\lambda_2 = \frac{1}{1.33} \times 5893\text{\AA} = 4431\text{\AA}$$

$$\lambda_2 = 4431\text{\AA}$$

(b) The equation relating the speed and refractive index is,

$$\frac{v_1}{v_2} = \frac{n_2}{n_1}$$

Rewriting, $v_2 = \frac{n_1}{n_2} \times v_1$

Substituting the values,

$$v_2 = \frac{1}{1.33} \times 3 \times 10^8 = 2.256 \times 10^8$$

$$v_2 = 2.256 \times 10^8 \text{ m s}^{-1}$$

(c) Frequency of light in vacuum is,

$$v_1 = \frac{c}{\lambda_1}$$

Substituting the values,

$$v_1 = \frac{3 \times 10^8}{5893 \times 10^{-10}} = 5.091 \times 10^{14} \text{ Hz}$$

Frequency of light in water is, $v_2 = \frac{v}{\lambda_2}$

Substituting the values,

$$v_2 = \frac{2.256 \times 10^8 \text{ m s}^{-1}}{4431 \times 10^{-10}} = 5.091 \times 10^{14} \text{ Hz}$$

The results show that the frequency remains same in all media.

6.10**INTERFERENCE**

The phenomenon of addition or superposition of two light waves which produces increase in intensity at some points and decrease in intensity at some other points is called *interference of light*.

Superposition of waves refers to addition of waves. The concept of superposition of mechanical waves is studied in (XI Physics 11.7). When two waves simultaneously pass through a particle in a medium, the resultant displacement of that particle is the vector addition of the displacements due to the individual waves. The resultant displacement will be maximum or minimum depending upon the phase difference between the two superimposing waves. These concepts hold good for light as well.

Let us consider two light waves from the two sources S_1 and S_2 meeting at a point P as shown in Figure 6.52.

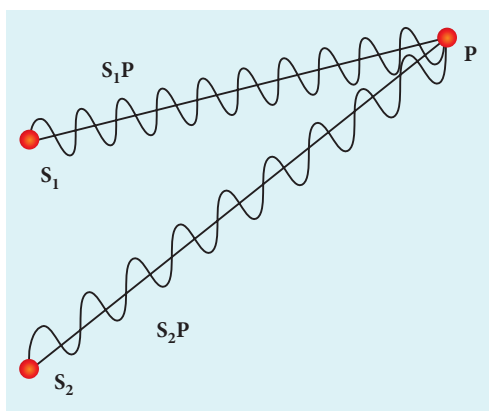

Figure 6.52 Superposition principle

The wave from S_1 at an instant t at P is,

$$y_1 = a_1 \sin \omega t \quad (6.117)$$

The wave form S_2 at an instant t at P is,

$$y_2 = a_2 \sin (\omega t + \phi) \quad (6.118)$$

The two waves have different amplitudes a_1 and a_2 , same angular frequency ω , and a phase difference of ϕ between them. The resultant displacement will be given by,

$$y = y_1 + y_2 = a_1 \sin \omega t + a_2 \sin (\omega t + \phi) \quad (6.119)$$

The simplification of the above equation by using trigonometric identities as done in (XI Physics 11.7) gives the equation,

$$y = A \sin (\omega t + \theta) \quad (6.120)$$

$$\text{Where, } A = \sqrt{a_1^2 + a_2^2 + 2a_1a_2 \cos \phi} \quad (6.121)$$

$$\theta = \tan^{-1} \frac{a_2 \sin \phi}{a_1 + a_2 \cos \phi} \quad (6.122)$$

The resultant amplitude is maximum,

$$A_{\max} = \sqrt{(a_1 + a_2)^2}; \text{ when } \phi = 0, \pm 2\pi, \pm 4\pi \dots, \quad (6.123)$$

The resultant amplitude is minimum,

$$A_{\min} = \sqrt{(a_1 - a_2)^2}; \text{ when } \phi = \pm \pi, \pm 3\pi, \pm 5\pi \dots, \quad (6.124)$$

The intensity of light is proportional to square of amplitude,

$$I \propto A^2 \quad (6.125)$$

Now, equation 6.121 becomes,

$$I \propto I_1 + I_2 + 2\sqrt{I_1 I_2} \cos \phi \quad (6.126)$$

In equation 6.126 if the phase difference, $\phi = 0, \pm 2\pi, \pm 4\pi \dots$, it corresponds to the condition for maximum intensity of light called as **constructive interference**.

The resultant maximum intensity is,

$$I_{\max} \propto (a_1 + a_2)^2 \propto I_1 + I_2 + 2\sqrt{I_1 I_2} \quad (6.127)$$

In equation 6.126 if the phase difference, $\phi = \pm \pi, \pm 3\pi, \pm 5\pi \dots$, it corresponds to the condition for minimum intensity of light called **destructive interference**.

The resultant minimum intensity is,

$$I_{\min} \propto (a_1 - a_2)^2 \propto I_1 + I_2 - 2\sqrt{I_1 I_2} \quad (6.128)$$

As a special case, if $a_1 = a_2 = a$, then equation 6.121. becomes,

$$A = \sqrt{2a^2 + 2a^2 \cos \phi} = \sqrt{2a^2(1 + \cos \phi)} \\ = \sqrt{2a^2 \cdot 2 \cos^2(\phi/2)}$$

$$A = 2a \cos(\phi/2) \quad (6.129)$$

$$I \propto 4a^2 \cos^2(\phi/2) \quad [\because I \propto A^2] \quad (6.130)$$

$$I = 4 I_0 \cos^2(\phi/2) \quad [\because I_0 \propto a^2] \quad (6.131)$$

$$I_{\max} = 4I_0 \text{ when, } \phi = 0, \pm 2\pi, \pm 4\pi \dots, \quad (6.132)$$

$$I_{\min} = 0 \text{ when, } \phi = \pm\pi, \pm 3\pi, \pm 5\pi \dots, \text{ (6.133)}$$

We conclude that the phase difference ϕ , between the two waves decides the intensity of light at that point where the two waves meet.

EXAMPLE 6.24

Two light sources with amplitudes 5 units and 3 units respectively interfere with each other. Calculate the ratio of maximum and minimum intensities.

Solution

Amplitudes, $a_1 = 5, a_2 = 3$

Resultant amplitude,

$$A = \sqrt{a_1^2 + a_2^2 + 2a_1a_2 \cos \phi}$$

Resultant amplitude is maximum when,

$$\phi = 0, \cos 0 = 1, A_{\max} = \sqrt{a_1^2 + a_2^2 + 2a_1a_2}$$

$$A_{\max} = \sqrt{(a_1 + a_2)^2} = \sqrt{(5 + 3)^2} = \sqrt{(8)^2} \\ = 8 \text{ units}$$

Resultant amplitude is minimum when,

$$\phi = \pi, \cos \pi = -1, A_{\min} = \sqrt{a_1^2 + a_2^2 - 2a_1a_2}$$

$$A_{\min} = \sqrt{(a_1 - a_2)^2} = \sqrt{(5 - 3)^2} = \sqrt{(2)^2} \\ = 2 \text{ units}$$

$$I \propto A^2$$

$$\frac{I_{\max}}{I_{\min}} = \frac{(A_{\max})^2}{(A_{\min})^2}$$

Substituting,

$$\frac{I_{\max}}{I_{\min}} = \frac{(8)^2}{(2)^2} = \frac{64}{4} = 16 \text{ (or)}$$

$$I_{\max} : I_{\min} = 16 : 1$$

EXAMPLE 6.25

Two light sources of equal amplitudes interfere with each other. Calculate the ratio of maximum and minimum intensities.

Solution

Let the amplitude be a .

The intensity is, $I \propto 4a^2 \cos^2(\phi/2)$

$$\text{or } I = 4I_0 \cos^2(\phi/2)$$

Resultant intensity is maximum when,

$$\phi = 0, \cos 0 = 1, I_{\max} \propto 4a^2$$

Resultant amplitude is minimum when,

$$\phi = \pi, \cos(\pi/2) = 0, I_{\min} = 0$$

$$I_{\max} : I_{\min} = 4a^2 : 0$$

EXAMPLE 6.26

Two light sources have intensity of light as I_0 . What is the resultant intensity at a point where the two light waves have a phase difference of $\pi/3$?

Solution

Let the intensities be I_0 .

The resultant intensity is, $I = 4 I_0 \cos^2(\phi/2)$

Resultant intensity when, $\phi = \pi/3$, is

$$I = 4I_0 \cos^2(\pi/6)$$

$$I = 4I_0 \left(\frac{\sqrt{3}}{2}\right)^2 = 3I_0$$

6.10.1 Phase difference and path difference

Phase is the angular position of a vibration. As a wave is progressing, there is a relation between the phase of the vibration and the path travelled by the wave. One

can express the phase in terms of path and vice versa. In the path of the wave, one wavelength λ corresponds to a phase of 2π as shown in Figure 6.53. A path difference δ corresponds to a phase difference ϕ as given by the equation,

$$\delta = \frac{\lambda}{2\pi} \times \phi \text{ (or) } \phi = \frac{2\pi}{\lambda} \times \delta \quad (6.134)$$

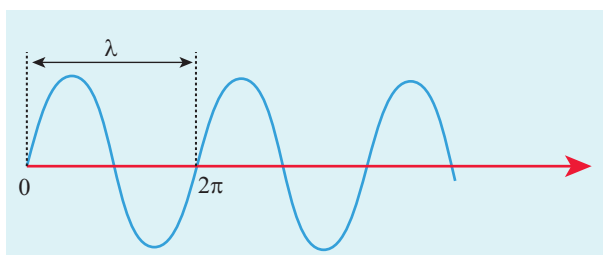

Figure 6.53 Path difference and phase difference

For constructive interference, the phase difference should be, $\phi = 0, 2\pi, 4\pi \dots$. Hence, the path difference must be, $\delta = 0, \lambda, 2\lambda \dots$. In general, the integral multiples of λ .

$$\delta = n\lambda \text{ where, } n = 0, 1, 2, 3 \dots \quad (6.135)$$

For destructive interference, phase difference should be, $\phi = \pi, 3\pi, 5\pi \dots$. Hence, the path difference must be, $\delta = \frac{\lambda}{2}, \frac{3\lambda}{2} \dots$.

In general, the half integral multiples of λ .

$$\delta = (2n - 1) \frac{\lambda}{2} \text{ where, } n = 1, 2, 3 \dots \quad (6.136)$$

EXAMPLE 6.27

The wavelength of a light is 450 nm. How much phase it will differ for a path of 3 mm?

Solution

The wavelength is, $\lambda = 450 \text{ nm} = 450 \times 10^{-9} \text{ m}$

Path difference is, $\delta = 3 \text{ mm} = 3 \times 10^{-3} \text{ m}$

Relation between phase difference and path difference is, $\phi = \frac{2\pi}{\lambda} \times \delta$

Substituting,

$$\phi = \frac{2\pi}{450 \times 10^{-9}} \times 3 \times 10^{-3} = \frac{\pi}{75} \times 10^6$$

$$\phi = \frac{\pi}{75} \times 10^6 \text{ rad}$$

6.10.2 Coherent sources

Two light sources are said to be coherent if they produce waves which have same phase or constant phase difference, same frequency or wavelength (monochromatic), same waveform and preferably same amplitude. Coherence is a property of waves that enables to obtain stationary interference patterns.

Two independent monochromatic sources can never be coherent, because they may emit waves of same frequency and same amplitude, but not with same phase. This is because, atoms while emitting light, produce change in phase due to thermal vibrations. Hence, these sources are said to be incoherent sources.

To obtain coherent light waves, we have three techniques. They are,

- (i) Intensity or amplitude division
- (ii) wavefront division
- (iii) source and images.

(i) **Intensity or amplitude division:** If we allow light to pass through a partially silvered mirror (beam splitter), both reflection and refraction take place simultaneously. As the two light beams are obtained from the same light source, the two divided light beams will be coherent beams. They will be either in-phase or at constant phase difference as shown in Figure 6.54. Instruments like

Michelson's interferometer, Fabry-Perrot etalon work on this principle.

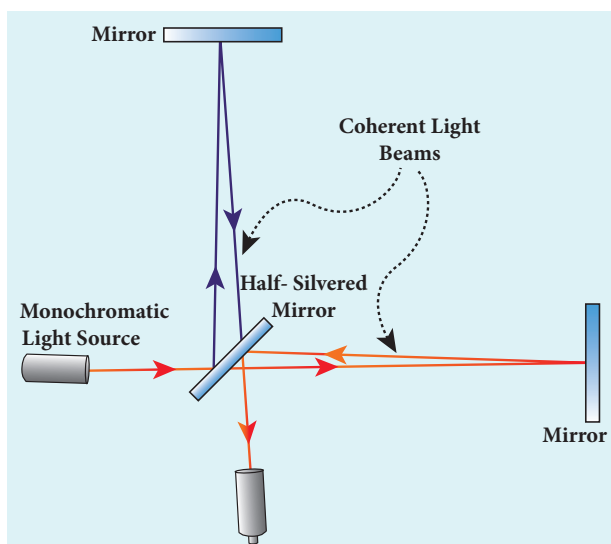

Figure 6.54 Intensity or amplitude division

(ii) **Wavefront division:** This is the most commonly used method for producing two coherent sources. We know a point source produces spherical wavefronts. All the points on the wavefront are at the same phase. If two points are chosen on the wavefront by using a double slit, the two points will act as coherent sources as shown in Figure 6.55.

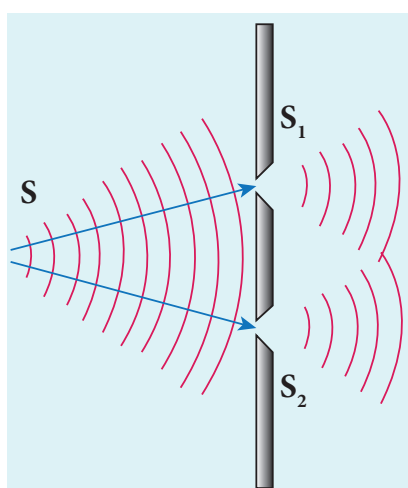

Figure 6.55 Wavefront division

(iii) **Source and images:** In this method a source and its image will act as a set of

coherent source, because the source and its image will have waves in-phase or constant phase difference as shown in Figure 6.56. The Instrument, Fresnel's biprism uses two virtual sources as two coherent sources and the instrument, Lloyd's mirror uses a source and its virtual image as two coherent sources.

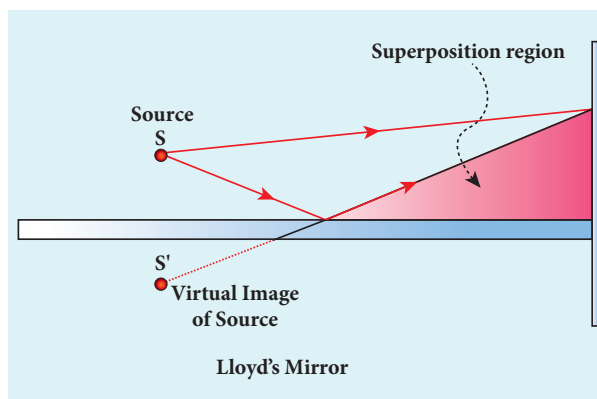
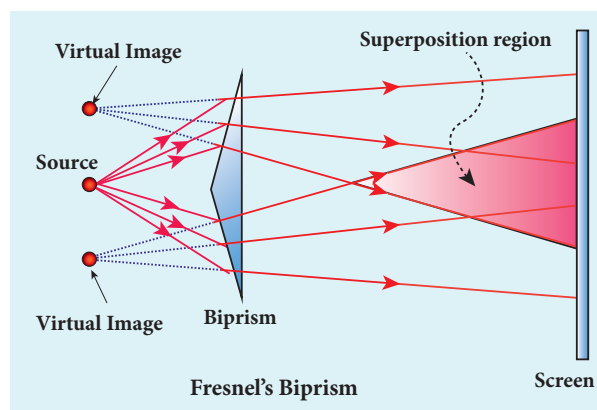

Figure 6.56 Using virtual and real images of a source as coherent sources

6.10.3 Double slit as coherent sources

Double slit uses the principle of wavefront division. Two slits S_1 and S_2 illuminated by a single monochromatic source S act as a set of coherent sources. The waves from these two coherent sources travel in the same medium and superpose. The constructive and destructive interference are shown in Figure 6.57(a). The crests of the waves are shown by thick continuous lines and troughs are shown by broken lines in Figure 6.57(b).

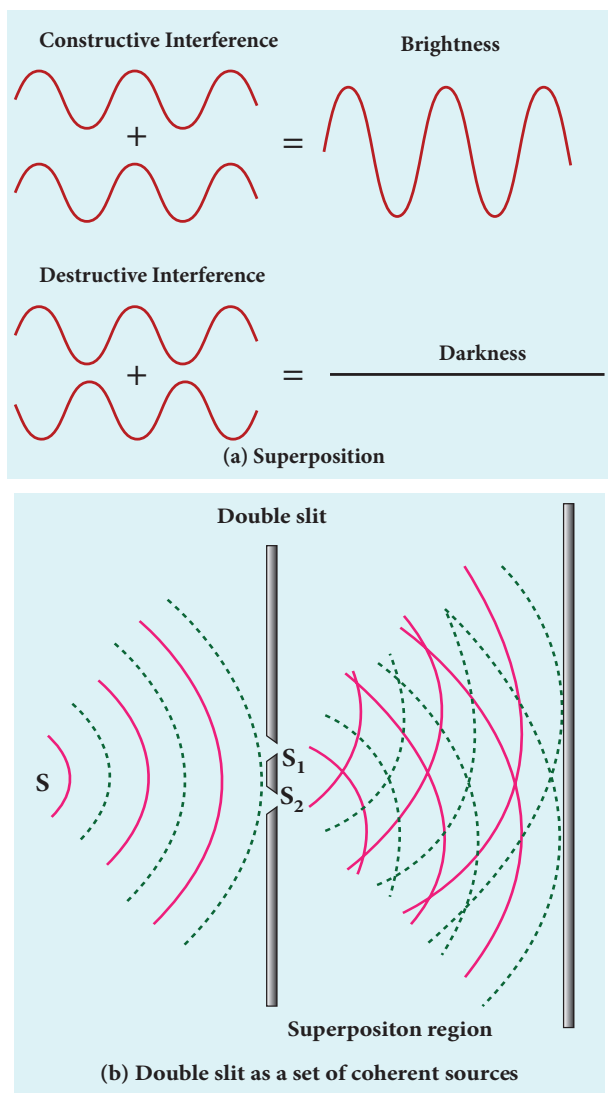

Figure 6.57 Interference due to double slit

At points where the crest of one wave meets the crest of the other wave or the trough of one wave meets the trough of the other wave, the waves are in-phase. Hence, the displacement is maximum and these points appear bright. This type of interference is said to be **constructive interference**.

At points where the crest of one wave meets the trough of the other wave and vice versa, the waves are out-of-phase. Hence, the displacement is minimum and these points appear dark. This type of interference is said to be **destructive interference**.

On a screen the intensity of light will be alternatively maximum and minimum i.e.

bright and dark bands which are referred to as interference fringes.

6.10.4 Young's double slit experiment

Thomas Young, a British Physicist used an opaque screen with two small openings called double slit S_1 and S_2 kept equidistance from a source S as shown in Figure 6.62. The width of each slit is about 0.03 mm and they are separated by a distance of about 0.3 mm. As S_1 and S_2 are equidistant from S , the light waves from S reach S_1 and S_2 in-phase. So, S_1 and S_2 act as coherent sources which are the requirement of obtaining interference pattern.

Experimental setup

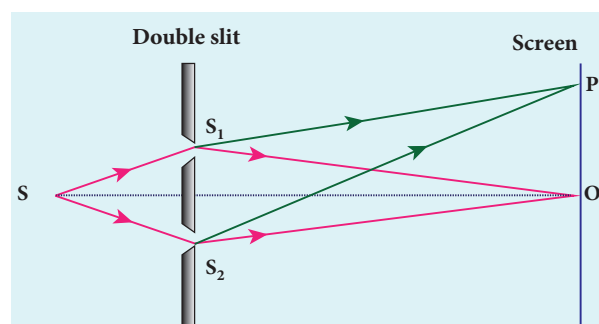

Figure 6.58 Young's double slit experiment

Wavefronts from S_1 and S_2 spread out and overlapping takes place to the right side of double slit. When a screen is placed at a distance of about 1 meter from the slits, alternate bright and dark fringes which are equally spaced appear on the screen. These are called interference fringes or bands. Using an eyepiece the fringes can be seen directly. At the center point O on the screen, waves from S_1 and S_2 travel equal distances and arrive in-phase as shown in Figure 6.58. These two waves constructively interfere and bright fringe is observed at O . This is called central bright fringe. The fringes

disappear and there is uniform illumination on the screen when one of the slits is covered. This shows clearly that the bands are due to interference.

Equation for path difference

The schematic diagram of the experimental set up is shown in Figure 6.59. Let d be the distance between the double slits S_1 and S_2 which act as coherent sources of wavelength λ . A screen is placed parallel to the double slit at a distance D from it. The mid-point of S_1 and S_2 is C and the mid-point of the screen O is equidistant from S_1 and S_2 . P is any point at a distance y from O . The waves from S_1 and S_2 meet at P either in-phase or out-of-phase depending upon the path difference between the two waves.

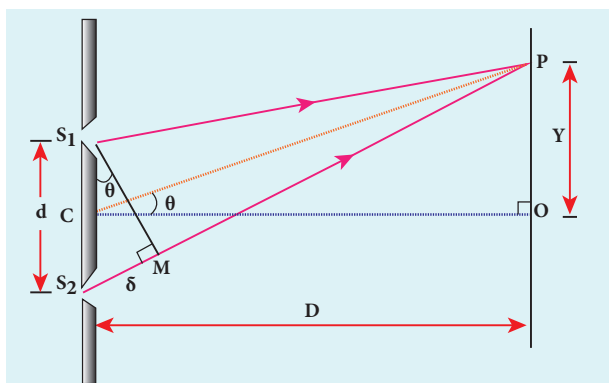

Figure 6.59 Young's double slit experimental setup

The path difference δ between the light waves from S_1 and S_2 to the point P is, $\delta = S_2P - S_1P$

A perpendicular is dropped from the point S_1 to the line S_2P at M to find the path difference more precisely.

$$\delta = S_2P - MP = S_2M \quad (6.137)$$

The angular position of the point P from C is θ . $\angle OCP = \theta$.

From the geometry, the angles $\angle OCP$ and $\angle S_2S_1M$ are equal.

$$\angle OCP = \angle S_2S_1M = \theta.$$

In right angle triangle ΔS_1S_2M , the path difference, $S_2M = d \sin \theta$

$$\delta = d \sin \theta \quad (6.138)$$

If the angle θ is small, $\sin \theta \approx \tan \theta \approx \theta$

From the right angle triangle ΔOCP , $\tan \theta = \frac{y}{D}$

$$\text{The path difference, } \delta = \frac{d y}{D} \quad (6.139)$$

Based on the condition on the path difference, the point P may have a bright or dark fringe.

Condition for bright fringe (or) maxima

The condition for the constructive interference or the point P to be have a bright fringe is,

$$\text{Path difference, } \delta = n\lambda$$

where, $n = 0, 1, 2, \dots$

$$\therefore \frac{d y}{D} = n\lambda$$

$$y = n \frac{\lambda D}{d} \quad (\text{or}) \quad y_n = n \frac{\lambda D}{d} \quad (6.140)$$

This is the condition for the point P to be a bright fringe. The distance is the distance of the n^{th} bright fringe from the point O .

Condition for dark fringe (or) minima

The condition for the destructive interference or the point P to be have a dark fringe is,

$$\text{Path difference, } \delta = (2n-1) \frac{\lambda}{2}$$

where, $n = 1, 2, 3 \dots$

$$\therefore \frac{d y}{D} = (2n-1) \frac{\lambda}{2}$$

$$y = \frac{(2n-1) \lambda D}{2 d} \quad (\text{or}) \quad y_n = \frac{(2n-1) \lambda D}{2 d} \quad (6.141)$$

This is the condition for the point P to be a dark fringe. The distance y_n is the distance of the n^{th} dark fringe from the point O.

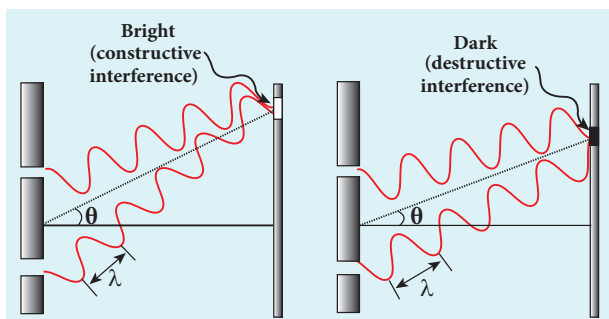

Figure 6.60 Formation of bright and dark fringes

The formation of bright and dark fringes is shown in Figure 6.60.

This shows that on the screen, alternate bright and dark bands are seen on either side of the central bright fringe. The central bright is referred as 0^{th} bright followed by 1^{st} dark and 1^{st} bright and then 2^{nd} dark and 2^{nd} bright and so on, on either side of O successively as shown in Figure 6.61.

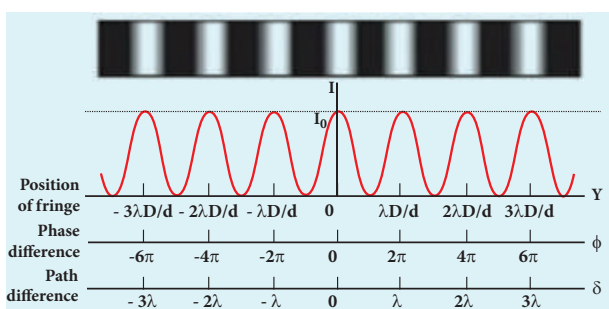

Figure 6.61 Interference fringe pattern

Equation for bandwidth

The **bandwidth** (β) is defined as the distance between any two consecutive bright or dark fringes.

The distance between $(n+1)^{\text{th}}$ and n^{th} consecutive bright fringes from O is given by,

$$\beta = y_{(n+1)} - y_n = \left((n+1) \frac{\lambda D}{d} \right) - \left(n \frac{\lambda D}{d} \right)$$

$$\beta = \frac{\lambda D}{d} \quad (6.142)$$

Similarly, the distance between $(n+1)^{\text{th}}$ and n^{th} consecutive dark fringes from O is given by,

$$\beta = y_{(n+1)} - y_n = \left(\frac{(2(n+1)-1) \lambda D}{2} \right) - \left(\frac{(2n-1) \lambda D}{2} \right)$$

$$\beta = \frac{\lambda D}{d} \quad (6.142)$$

Equations (6.142) show that the bright and dark fringes are of same width equally spaced on either side of central bright fringe.

Conditions for obtaining clear and broad interference bands

- The screen should be as far away from the source as possible.
- The wavelength of light used must be larger.
- The two coherent sources (here S_1 and S_2) must be as close as possible.

EXAMPLE 6.28

In Young's double slit experiment, the two slits are 0.15 mm apart. The light source has a wavelength of 450 nm. The screen is 2 m away from the slits.

- Find the distance of the second bright fringe and also third dark fringe from the central maximum.
- Find the fringe width.
- How will the fringe pattern change if the screen is moved away from the slits?
- What will happen to the fringe width if the whole setup is immersed in water of refractive index $4/3$.

Solution

$$d = 0.15 \text{ mm} = 0.15 \times 10^{-3} \text{ m}; D = 2 \text{ m};$$
$$\lambda = 450 \text{ nm} = 450 \times 10^{-9} \text{ m}; n = 4/3$$

(i) Equation for n^{th} bright fringe is,

$$y_n = n \frac{\lambda D}{d}$$

Distance of 2nd bright fringe is,

$$y_2 = 2 \times \frac{450 \times 10^{-9} \times 2}{0.15 \times 10^{-3}}$$

$$y_2 = 12 \times 10^{-3} \text{ m} = 12 \text{ mm}$$

Equation for n^{th} dark fringe is,

$$y_n = \frac{(2n-1) \lambda D}{2d}$$

Distance of 3rd dark fringe is,

$$y_3 = \frac{5}{2} \times \frac{450 \times 10^{-9} \times 2}{0.15 \times 10^{-3}}$$

$$y_3 = 15 \times 10^{-3} \text{ m} = 15 \text{ mm}$$

(ii) Equation for fringe width is, $\beta = \frac{\lambda D}{d}$

$$\text{Substituting, } \beta = \frac{450 \times 10^{-9} \times 2}{0.15 \times 10^{-3}}$$

$$\beta = 6 \times 10^{-3} \text{ m} = 6 \text{ mm}$$

(iii) The fringe width will increase as D is increased, $\beta = \frac{\lambda D}{d}$ (or) $\beta \propto D$

(iv) The fringe width will decrease as the setup is immersed in water of refractive index $4/3$

$$\beta = \frac{\lambda D}{d} \quad (\text{or}) \quad \beta \propto \lambda$$

The wavelength will decrease refractive index n times. Hence, $\beta \propto \lambda$ and $\beta' \propto \lambda'$

$$\text{We know that, } \lambda' = \frac{\lambda}{n}$$

$$\frac{\beta'}{\beta} = \frac{\lambda'}{\lambda} = \frac{\lambda/n}{\lambda} = \frac{1}{n} \quad (\text{or}) \quad \beta' = \frac{\beta}{n} = \frac{6 \times 10^{-3}}{4/3}$$

$$\beta' = 4.5 \times 10^{-3} \text{ m} = 4.5 \text{ mm}$$

6.10.5 Interference with polychromatic light

When a polychromatic light (white light) is used in interference experiment, coloured fringes of varied thickness will be formed on the screen. This is because, different colours have different wavelengths. However, the central fringe or 0th fringe will always be bright and white in colour, because for all the colours falling at the point O will have no path difference. Hence, only constructive interference is possible at O for all the colours.

EXAMPLE 6.29

Two lights of wavelengths 560 nm and 420 nm are used in Young's double slit experiment. Find the least distance from the central fringe where the bright fringe of the two wavelengths coincides. Given $D = 1 \text{ m}$ and $d = 3 \text{ mm}$.

Solution

$$\lambda_1 = 560 \text{ nm} = 560 \times 10^{-9} \text{ m};$$

$$\lambda_2 = 420 \text{ nm} = 420 \times 10^{-9} \text{ m};$$

$$D = 1 \text{ m}; d = 3 \text{ mm} = 3 \times 10^{-3} \text{ m}$$

For a given y , n and λ are inversely proportional.

Let n^{th} order bright fringe of λ_1 coincides with $(n+1)^{\text{th}}$ order bright fringe of λ_2 .

$$\text{Equation for } n^{\text{th}} \text{ bright fringe is, } y_n = n \frac{\lambda D}{d}$$

$$\text{Here, } n \frac{\lambda_1 D}{d} = (n+1) \frac{\lambda_2 D}{d} \quad (\text{as } \lambda_1 > \lambda_2)$$

$$n\lambda_1 = (n+1)\lambda_2 \quad (\text{or}) \quad \frac{\lambda_1}{\lambda_2} = \frac{(n+1)}{n}$$

$$1 + \frac{1}{n} = \frac{560 \times 10^{-9}}{420 \times 10^{-9}} \quad (\text{or}) \quad 1 + \frac{1}{n} = \frac{4}{3}$$



Dazzling colours are exhibited by thin films of oil spread on the surface of water and also by soap bubbles as shown in the figure. These colours are due to interference of white light undergoing multiple reflections from the top and the bottom surfaces of thin films. The colour depends upon the thickness of the film, refractive index of the film and also the angle of incidence of the light.



$$\frac{1}{n} = \frac{1}{3} \text{ (or) } n = 3$$

Thus, the 3rd bright fringe of λ_1 and 4th bright fringe of λ_2 coincide at the least distance y .

The least distance from the central fringe where the bright fringes of the two wavelengths coincides is, $y_n = n \frac{\lambda D}{d}$

$$y_n = 3 \times \frac{560 \times 10^{-9} \times 1}{3 \times 10^{-3}} = 560 \times 10^{-6} \text{ m}$$

$$y_n = 0.560 \times 10^{-3} \text{ m} = 0.560 \text{ mm}$$

6.10.6 Interference in thin films

Let us consider a thin film of transparent material of refractive index μ (not to confuse with order of fringe n) and thickness d . A parallel beam of light is incident on the film at an angle i as shown in Figure 6.62. The wave is divided into two parts at the upper surface, one is reflected and the other is refracted. The refracted part, which enters into the film, again gets divided at

the lower surface into two parts; one is transmitted out of the film and the other is reflected back in to the film. Reflected as well as refracted waves are sent by the film as multiple reflections take place inside the film. The interference is produced by both the reflected and transmitted light.

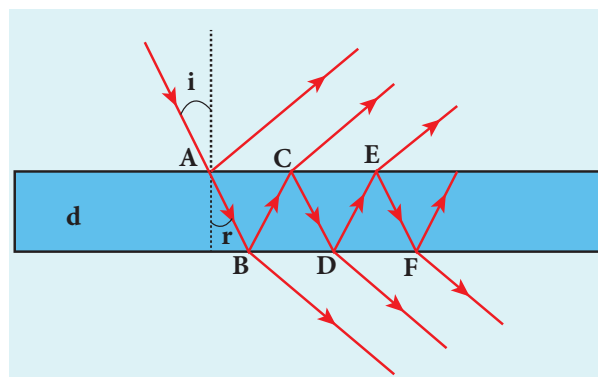

Figure 6.62 Interference in thin films

For transmitted light

The light transmitted may interfere to produce a resultant intensity. Let us consider the path difference between the two light waves transmitted from B and D. The two waves moved together and remained in phase up to B where splitting

occurred. The extra path travelled by the wave transmitted from D is the path inside the film, $BC + CD$. If we approximate the incidence to be nearly normal ($i = 0$), then the points B and D are very close to each other. The extra distance travelled by the wave is approximately twice thickness of the film, $BC + CD = 2d$. As this extra path is traversed in a medium of refractive index μ , the optical path difference is, $\delta = 2\mu d$.

The condition for constructive interference in transmitted ray is,

$$2\mu d = n\lambda \quad (6.143)$$

Similarly, the condition for destructive interference in transmitted ray is,

$$2\mu d = (2n - 1)\frac{\lambda}{2} \quad (6.144)$$

For reflected light

It is experimentally and theoretically proved that a wave while travelling in a rarer medium and getting reflected by a denser medium, undergoes a phase change of π . Hence, an additional path difference of $\lambda/2$ should be considered.

Let us consider the path difference between the light waves reflected by the upper surface at A and the other wave coming out at C after passing through the film. The additional path travelled by wave coming out from C is the path inside the film, $AB + BC$. For nearly normal incidence this distance could be approximated as, $AB + BC = 2d$. As this extra path is travelled in the medium of refractive index μ , the optical path difference is, $\delta = 2\mu d$.

The condition for constructive interference for reflected ray is,

$$2\mu d + \frac{\lambda}{2} = n\lambda \quad (\text{or}) \quad 2\mu d = (2n - 1)\frac{\lambda}{2} \quad (6.145)$$

The additional path difference $\lambda/2$ is due to the phase change of π in rarer to denser reflection taking place at A .

The condition for destructive interference for reflected ray is,

$$2\mu d + \frac{\lambda}{2} = (2n + 1)\frac{\lambda}{2} \quad (\text{or}) \quad 2\mu d = n\lambda \quad (6.146)$$



If the incidence is not nearly normal, but at an angle of incidence i which has an angle of refraction r , then the expression for path difference $2\mu d$ on the left hand side of the above equations are to be replaced with the expression, $2\mu d \cos r$.

EXAMPLE 6.30

Find the minimum thickness of a film of refractive index 1.25, which will strongly reflect the light of wavelength 589 nm. Also find the minimum thickness of the film to be anti-reflecting.

Solution

$$\lambda = 589 \text{ nm} = 589 \times 10^{-9} \text{ m}$$

For the film to have strong reflection, the reflected waves should interfere constructively. The least optical path difference introduced by the film should be $\lambda/2$. The optical path difference between the waves reflected from the two surfaces of the film is $2\mu d$. Thus, for strong reflection, $2\mu d = \lambda/2$ [As given in equation 6.145. with $n = 1$]

$$\text{Rewriting, } d = \frac{\lambda}{4\mu}$$

$$\text{Substituting, } d = \frac{589 \times 10^9}{4 \times 1.25} = 117.8 \times 10^{-9}$$

$$d = 117.8 \times 10^{-9} = 117.8 \text{ nm}$$

For the film to be anti-reflecting, the reflected rays should interfere destructively. The least optical path difference introduced by the film should be λ . The optical path difference between the waves reflected from the two surfaces of the film is $2\mu d$. For strong reflection, $2\mu d = \lambda$ [As given in equation 6.146. with $n = 1$].

$$\text{Rewriting, } d = \frac{\lambda}{2\mu}$$

$$\text{Substituting, } d = \frac{589 \times 10^9}{2 \times 1.25} = 235.6 \times 10^{-9}$$

$$d = 235.6 \times 10^{-9} = 235.6 \text{ nm}$$

is a violation to the rectilinear propagation of light, we have studied in ray optics, which says light should travel in straight line in a medium without bending. But, the diffraction is prominent only when the size of the obstacle is comparable to the wavelength of light. This is the reason why sound waves get diffracted prominently by obstacles like doors, windows, buildings etc. The wavelength of sound wave is large and comparable to the geometry of these obstacles. But the diffraction in light is more pronounced when the obstacle size is of the order of wavelength of light.

6.11 DIFFRACTION

Diffraction is a general characteristic of all types of waves, be it sound wave, light wave, water wave etc. **Diffraction is bending of waves around sharp edges into the geometrically shadowed region.** This

6.11.1 Fresnel and Fraunhofer diffractions

Based on the type of wavefront which undergoes diffraction, the diffraction could be classified as Fresnel and Fraunhofer diffractions. The differences between Fresnel and Fraunhofer diffractions are shown in Table 6.4.

Table 6.4 Difference between Fresnel and Fraunhofer diffractions

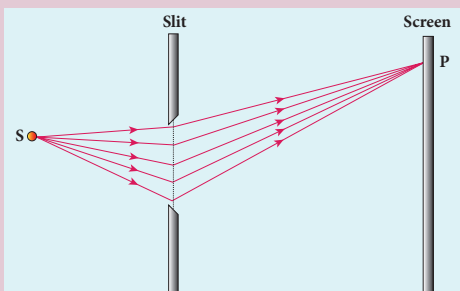
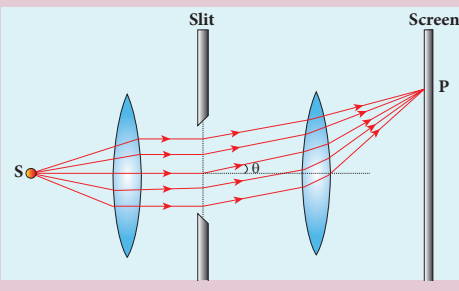
S.No.	Fresnel diffraction	Fraunhofer diffraction
1	Spherical or cylindrical wavefront undergoes diffraction	Plane wavefront undergoes diffraction
2	Light wave is from a source at finite distance	Light wave is from a source at infinity
3	For laboratory conditions, convex lenses need not be used	In laboratory conditions, convex lenses are to be used
4	Difficult to observe and analyse	Easy to observe and analyse
5		

As Fraunhofer diffraction is easy to observe and analyse, let us take it up for further discussions.

6.11.2. Diffraction at single slit

Let a parallel beam of light fall normally on a single slit AB of width a as shown in Figure 6.63. The diffracted beam falls on a screen kept at a distance. The center of the slit is C . A straight line through C perpendicular to the plane of slit meets the center of the screen at O . We would like to find the intensity at any point P on the screen. The lines joining P to the different points on the slit can be treated as parallel lines, making an angle θ with the normal CO .

All the waves start parallel to each other from different points of the slit and interfere at point P and other points to give the resultant intensities. The point P is in the geometrically shadowed region, up to which the central maximum is spread due to diffraction as shown Figure 6.63. We need to give the condition for the point P to be of various minima.

The basic idea is to divide the slit into much smaller even number of parts. Then, add their contributions at P with the proper path difference to show that destructive interference takes place at that point to make it minimum. To explain maximum, the slit is divided into odd number of parts.

Condition for P to be first minimum

Let us divide the slit AB into two half's AC and CB . Now the width of AC is $(a/2)$. We have different points on the slit which are separated by the same width (here $a/2$) called *corresponding points* as shown in Figure 6.64.

The path difference of light waves from different corresponding points meeting at point P and interfere destructively to make it first minimum. The path difference δ between waves from these corresponding points is, $\delta = \frac{a}{2} \sin \theta$

The condition for P to be first minimum,

$$\frac{a}{2} \sin \theta = \frac{\lambda}{2}$$

$$a \sin \theta = \lambda \text{ (first minimum) (6.147)}$$

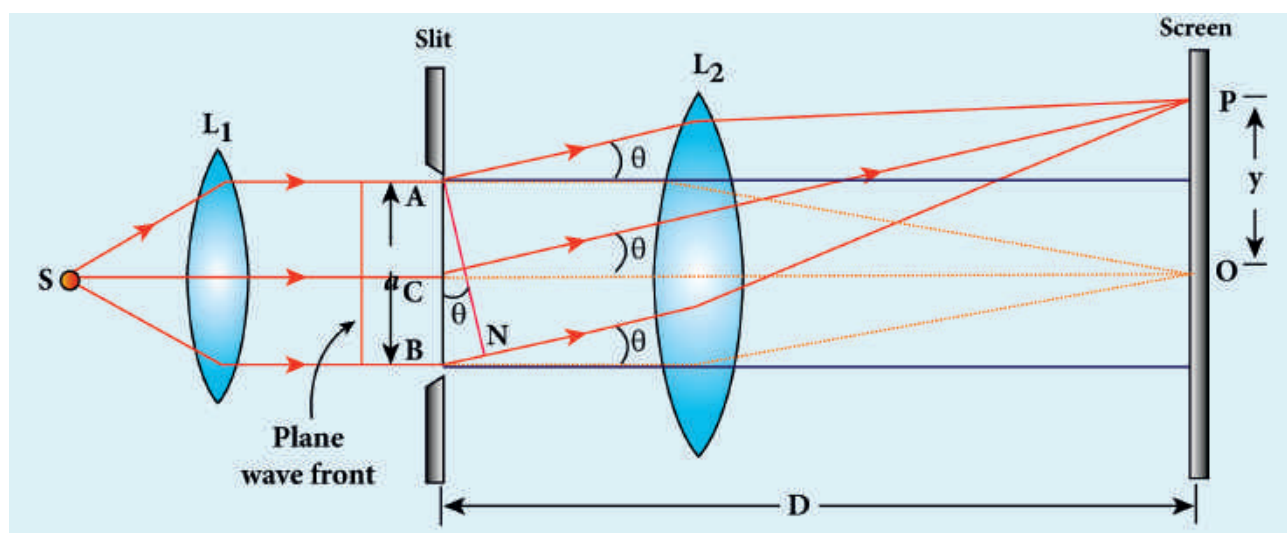

Figure 6.63 Diffraction at single slit

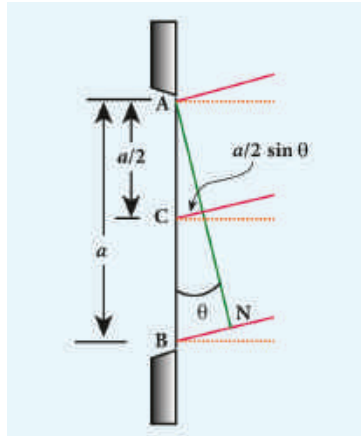

Figure 6.64 Corresponding points

Condition for P to be second minimum

Let us divide the slit AB into four equal parts. Now, the width of each part is $a/4$. We have several corresponding points on the slit which are separated by the same width $a/4$. The path difference δ between waves from these corresponding points is, $\delta = \frac{a}{4} \sin \theta$.

The condition for P to be second minimum, $\frac{a}{4} \sin \theta = \frac{\lambda}{2}$

$$a \sin \theta = 2\lambda \text{ (second minimum) } \quad (6.148)$$

Condition for P to be third order minimum

The same way the slit is divided in to six equal parts to explain the condition for P to be third minimum is, $\frac{a}{6} \sin \theta = \frac{\lambda}{2}$

$$a \sin \theta = 3\lambda \text{ (third minimum) } \quad (6.149)$$

Condition for P to be nth order minimum

Dividing the slit into $2n$ number of (even number of) equal parts makes the light produced by one of the corresponding points to be cancelled by its counterpart. Thus, the condition for n^{th} order minimum is, $\frac{a}{2n} \sin \theta = \frac{\lambda}{2}$

$$a \sin \theta = n\lambda \text{ (nth minimum) } \quad (6.150)$$

Condition for maxima

For points of maxima, the slit is to be divided in to odd number of equal parts so that one part remains un-cancelled making the point P appear bright.

The condition for first maximum is,

$$\frac{a}{3} \sin \theta = \frac{\lambda}{2} \text{ (or) } a \sin \theta = \frac{3\lambda}{2} \quad (6.151)$$

The condition for second maximum is,

$$\frac{a}{5} \sin \theta = \frac{\lambda}{2} \text{ (or) } a \sin \theta = \frac{5\lambda}{2} \quad (6.152)$$

The condition for third maximum is,

$$\frac{a}{7} \sin \theta = \frac{\lambda}{2} \text{ (or) } a \sin \theta = \frac{7\lambda}{2} \quad (6.153)$$

In the same way, condition for n^{th} maximum is,

$$a \sin \theta = (2n + 1) \frac{\lambda}{2} \text{ (nth maximum) } \quad (6.154)$$

where, $n = 0, 1, 2, 3, \dots$, is the order of diffraction maximum.

The central maximum is called 0^{th} order maximum. The points of the maximum intensity lie nearly midway between the successive minima.



Here, $\sin \theta$ gives the angular spread of the diffraction. The position of the minimum or maximum in terms of y may be expressed by replacing $\sin \theta$ approximated by $\tan \theta$, as θ is small, $\sin \theta = \tan \theta \frac{y}{D}$

Where, y is the position of the minimum from the center of the screen and D is the distance between single slit and the screen.

EXAMPLE 6.31

Light of wavelength 500 nm passes through a slit of 0.2 mm wide. The diffraction pattern is formed on a screen 60 cm away. Determine the,

- angular spread of central maximum
- the distance between the central maximum and the second minimum.

Solution

$\lambda = 500 \text{ nm} = 500 \times 10^{-9} \text{ m}$; $a = 0.2 \text{ mm} = 0.2 \times 10^{-3} \text{ m}$; $D = 60 \text{ cm} = 60 \times 10^{-2} \text{ m}$

- Equation for diffraction minimum is, $a \sin \theta = n\lambda$

The central maximum is spread up to the first minimum. Hence, $n = 1$

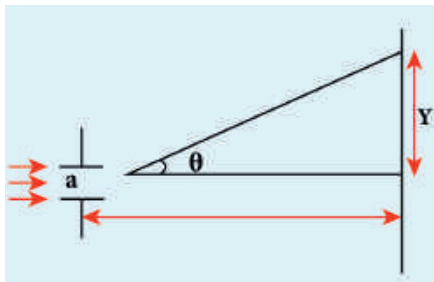

Rewriting, $\sin \theta = \frac{\lambda}{a}$ (or) $\theta = \sin^{-1} \left(\frac{\lambda}{a} \right)$

Substituting,

$$\theta = \sin^{-1} \left(\frac{500 \times 10^{-9}}{0.2 \times 10^{-3}} \right) = \sin^{-1} (2.5 \times 10^{-3})$$

$$\theta = 0.0025 \text{ rad}$$

- To find the value of y_1 for central maximum, which is spread up to first minimum with ($n = 1$) is, $a \sin \theta = \lambda$

As θ is very small, $\sin \theta \approx \tan \theta = \frac{y_1}{D}$

$$a \frac{y_1}{D} = \lambda \quad \text{rewriting, } y_1 = \frac{\lambda D}{a}$$

Substituting,

$$y_1 = \frac{500 \times 10^{-9} \times 60 \times 10^{-2}}{0.2 \times 10^{-3}} = 1.5 \times 10^{-3} = 1.5 \text{ mm}$$

To find the value of y_2 for second minimum with ($n = 2$) is, $a \sin \theta = 2\lambda$

$$a \frac{y_2}{D} = 2\lambda \quad \text{rewriting, } y_2 = \frac{2\lambda D}{a}$$

Substituting,

$$y_2 = \frac{2 \times 500 \times 10^{-9} \times 60 \times 10^{-2}}{0.2 \times 10^{-3}} = 3 \times 10^{-3} = 3 \text{ mm}$$

The distance between the central maximum and second minimum is, $y_2 - y_1$

$$y_2 - y_1 = 3 \text{ mm} - 1.5 \text{ mm} = 1.5 \text{ mm}$$

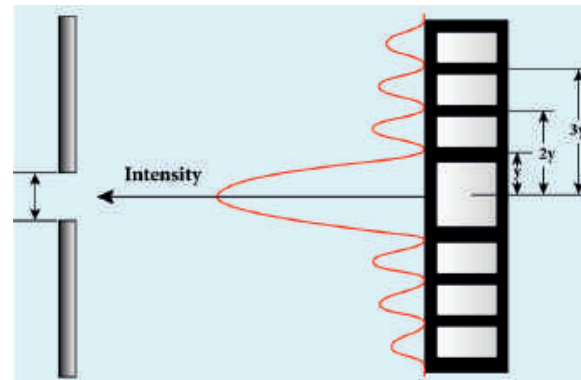

Note: The above calculation shows that in the diffraction pattern caused by single slit, the width of each maximum is equal with central maximum as the double that of others. But the bright and dark fringes are not of equal width.

EXAMPLE 6.32

A monochromatic light of wavelength 5000 Å passes through a single slit producing diffraction pattern for the central maximum as shown in the figure. Determine the width of the slit.

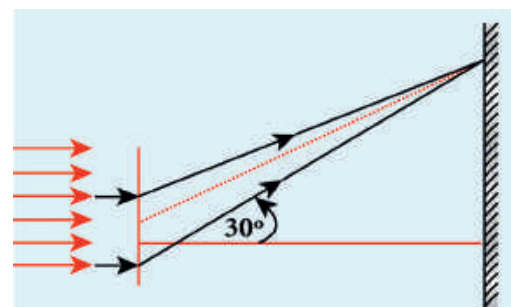

Solution

$$\lambda = 5000 \text{ \AA} = 5000 \times 10^{-10} \text{ m}; \sin 30^\circ = 0.5;$$
$$n = 1; a = ?$$

Equation for diffraction minimum is,
 $a \sin \theta = n\lambda$

The central maximum is spread up to the first minimum. Hence, $n = 1$

$$\text{Rewriting, } a = \frac{\lambda}{\sin \theta}$$

$$\text{Substituting, } a = \frac{5000 \times 10^{-10}}{0.5}$$

$$a = 1 \times 10^{-6} \text{ m} = 0.001 \times 10^{-3} \text{ m} = 0.001 \text{ mm}$$

6.11.3 Discussion on first minimum

Let us consider the condition for first minimum with ($n = 1$). $a \sin \theta = \lambda$

The first minimum has an angular spread of, $\sin \theta = \frac{\lambda}{a}$

Now, we have special cases to discuss on the above condition.

(i) When $a < \lambda$, the diffraction is not possible, because $\sin \theta$ can never be greater than 1.

(ii) When $a \geq \lambda$, the diffraction is possible.

- ▶ For $a = \lambda$, $\sin \theta = 1$ i.e., $\theta = 90^\circ$. That means the first minimum is at 90° . Hence, the central maximum spreads fully in to the geometrically shadowed region leading to bending of the diffracted light to 90° .
- ▶ For $a \gg \lambda$, $\sin \theta \ll 1$ i.e., the first minimum will fall within the width of the slit itself. The diffraction will not be noticed at all.

(iii) When $a > \lambda$ and also comparable, say $a = 2\lambda$, $\sin \theta = \frac{\lambda}{a} = \frac{\lambda}{2\lambda} = \frac{1}{2}$; then

$$\text{say } a = 2\lambda, \sin \theta = \frac{\lambda}{a} = \frac{\lambda}{2\lambda} = \frac{1}{2}; \text{ then}$$

$\theta = 30^\circ$. These are practical cases where diffraction could be observed effectively.

6.11.4 Fresnel's distance

Fresnel's distance is the distance up to which the ray optics is valid in terms of rectilinear propagation of light. As there is bending of light in diffraction, the rectilinear propagation of light is violated. But, this bending is not significant till the diffracted ray crosses the central maximum at a distance z as shown in Figure 6.65. Hence, Fresnel's distance is the distance upto which ray optics is obeyed and beyond which ray optics is not obeyed but, wave optics becomes significant.

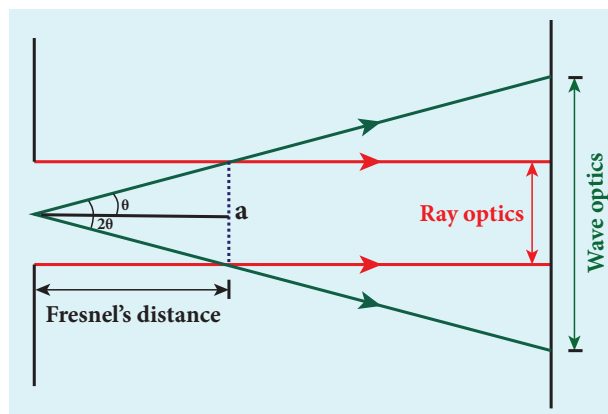

Figure 6.65 Fresnel's distance

From the diffraction equation for first minimum, $\sin \theta = \frac{\lambda}{a}$; $\theta = \frac{\lambda}{a}$

From the definition of Fresnel's distance,

$$\sin 2\theta = \frac{a}{z}; 2\theta = \frac{a}{z}$$

Equating the above two equation gives,

$$\frac{\lambda}{a} = \frac{a}{2z}$$

After rearranging, we get Fresnel's distance z as,

$$z = \frac{a^2}{2\lambda} \quad (6.155)$$

EXAMPLE 6.33

Calculate the distance for which ray optics is good approximation for an aperture of 5 mm and wavelength 500 nm.

Solution

$$a = 5 \text{ mm} = 5 \times 10^{-3} \text{ m};$$

$$\lambda = 500 \text{ nm} = 500 \times 10^{-9} \text{ m}; z = ?$$

Equation for Fresnel's distance, $z = \frac{a^2}{2\lambda}$

Substituting,

$$z = \frac{(5 \times 10^{-3})^2}{2 \times 500 \times 10^{-9}} = \frac{25 \times 10^{-6}}{1 \times 10^{-6}} = 25 \text{ m}$$

$$z = 25 \text{ m}$$

6.11.5 Difference between interference and diffraction

It is very difficult to distinguish between interference and diffraction as they both exhibit the wave nature of light. In both the phenomena the light reaches the geometrically shadowed regions and also interferes to produce maxima and minima. Nevertheless, based on the appearance, the differences are given in Table 6.5.

Table 6.5 Difference between interference and diffraction

S.No.	Interference	Diffraction
1	Superposition of two waves	Bending of waves around edges
2	Superposition of waves from two coherent sources.	Superposition wavefronts emitted from various points of the same wavefront.
3	Equally spaced fringes.	Unequally spaced fringes
4	Intensity of all the bright fringes is almost same	Intensity falls rapidly for higher orders
5	Large number of fringes are obtained	Less number of fringes are obtained

6.11.6 Diffraction in grating

Grating has multiple slits with equal widths of size comparable to the wavelength of diffracting light. Grating is a plane sheet of transparent material on which opaque rulings are made with a fine diamond pointer. The modern commercial grating contains about 6000 lines per centimetre. The rulings act as obstacles having a definite width b and the transparent space between the rulings act as slit of width a . **The combined width of a ruling and a slit is called grating element ($e = a + b$).** Points on successive slits separated by a distance equal to the grating element are called **corresponding points**.

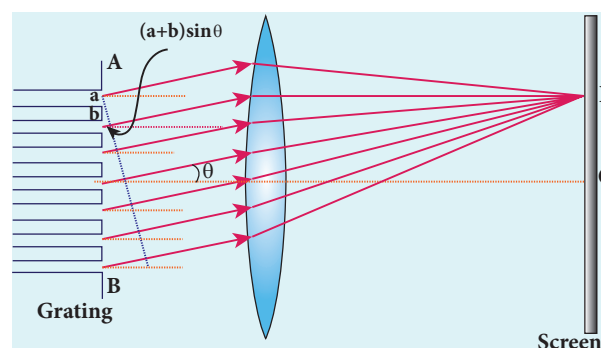

Figure 6.66 Diffraction grating experiment

A plane transmission grating is represented by AB in Figure 6.66. Let a

plane wavefront of monochromatic light with wave length λ be incident normally on the grating. As the slits size is comparable to that of wavelength, the incident light diffracts at the grating.

A diffraction pattern is obtained on the screen when the diffracted waves are focused on a screen using a convex lens. Let us consider a point P at an angle θ with the normal drawn from the center of the grating to the screen. The path difference δ between the diffracted waves from one pair of corresponding points is,

$$\delta = (a + b) \sin\theta \quad (6.156)$$

This path difference is the same for any pair of corresponding points. The point P will be bright, when

$$\delta = m \lambda \text{ where } m = 0, 1, 2, 3 \quad (6.157)$$

Combining the above two equations, we get,

$$(a + b) \sin\theta = m \lambda \quad (6.158)$$

Here, m is called order of diffraction.

Condition for zero order maximum, $m = 0$

For $(a + b) \sin\theta = 0$, the position, $\theta = 0$. $\sin\theta = 0$ and $m = 0$. This is called zero order diffraction or central maximum.

Condition for first order maximum, $m = 1$

If $(a + b) \sin\theta_1 = \lambda$, the diffracted light meet at an angle θ_1 to the incident direction and the first order maximum is obtained.

Condition for second order maximum, $m = 2$

Similarly, $(a + b) \sin\theta_2 = 2\lambda$ forms the second order maximum at the angular position θ_2 .

Condition for higher order maximum

On either side of central maxima different higher orders of diffraction maxima are formed at different angular positions.

If we take,

$$N = \frac{1}{a + b} \quad (6.159)$$

Then, N gives the number of grating elements or rulings drawn per unit width of the grating. Normally, this number N is specified on the grating itself. Now, the equation becomes,

$$\frac{1}{N} \sin\theta = m\lambda \text{ (or) } \sin\theta = Nm\lambda \quad (6.160)$$



Note The students should remember that in a single slit experiment the formula, $a \sin\theta = n\lambda$ is condition for minimum with n as order of minimum. But, the formula in diffraction grating, $\sin\theta = Nm\lambda$ is condition for maxima with m as the order of diffraction.

EXAMPLE 6.34

A diffraction grating consisting of 4000 slits per centimeter is illuminated with a monochromatic light that produces the second order diffraction at an angle of 30° . What is the wavelength of the light used?

Solution

Number of lines per cm = 4000; $m = 2$;

$\theta = 30^\circ$; $\lambda = ?$

Number of lines per unit length,

$$N = \frac{4000}{1 \times 10^{-2}} = 4 \times 10^5$$

Equation for diffraction maximum in grating is, $\sin\theta = Nm\lambda$

Rewriting, $\lambda = \frac{\sin\theta}{Nm}$

Substituting,

$$\lambda = \frac{\sin 30^\circ}{4 \times 10^5 \times 2} = \frac{0.5}{4 \times 10^5 \times 2}$$

$$= \frac{1}{2 \times 4 \times 10^5 \times 2} = \frac{1}{16 \times 10^5}$$

$$\lambda = 6250 \times 10^{-10} \text{ m} = 6250 \text{ \AA}$$

number of lines per centimeter =

$$2.5 \times 10^5 \times 10^{-2} = 2500 \text{ lines per centimetre}$$

EXAMPLE 6.35

A monochromatic light of wavelength of 500 nm strikes a grating and produces fourth order bright line at an angle of 30° . Find the number of slits per centimeter.

Solution

$$\lambda = 500 \text{ nm} = 500 \times 10^{-9} \text{ m}; m = 4;$$

$$\theta = 30^\circ; \text{ number of lines per cm} = ?$$

Equation for diffraction maximum in grating is, $\sin \theta = Nm \lambda$

$$\text{Rewriting, } N = \frac{\sin \theta}{m \lambda}$$

Substituting,

$$N = \frac{0.5}{4 \times 500 \times 10^{-9}} = \frac{1}{2 \times 4 \times 500 \times 10^{-9}}$$

$$= 2.5 \times 10^5 \text{ lines per meter}$$

6.11.7 Experiment to determine the wavelength of monochromatic light

The wavelength of a spectral line can be very accurately determined with the help of a diffraction grating and a spectrometer. Initially all the preliminary adjustments of the spectrometer are made. The slit of collimator is illuminated by a monochromatic light, whose wavelength is to be determined. The telescope is brought in line with collimator to view the image of the slit. The given plane transmission grating is then mounted on the prism table with its plane perpendicular to the incident beam of light coming from the collimator. The telescope is turned to one side until the first order diffraction image of the slit coincides with the vertical cross wire of the eye piece. The reading of the position of the telescope is noted.

Similarly the first order diffraction image on the other side is made to coincide with

DO YOU KNOW? You would have noticed the colourful appearance of the compact disc. On the read/writable side which is polished, there are many narrow circular tracks with widths comparable to the wavelength of visible light. Hence, the diffraction takes place after reflection for incident white light to give colourful appearance. The tracks act as reflecting grating.



the vertical cross wire and corresponding reading is noted. The difference between two positions gives 2θ . Half of its value gives θ , the diffraction angle for first order maximum as shown in Figure 6.67. The wavelength of light is calculated from the equation,

$$\lambda = \frac{\sin \theta}{Nm} \quad (6.161)$$

Here, N is the number of rulings per metre in the grating and m is the order of the diffraction image.

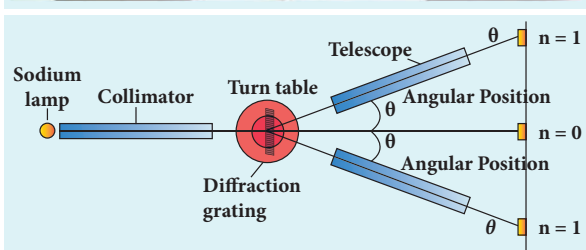

Figure 6.67 Determination of wavelength using grating and spectrometer

6.11.8 Determination of wavelength of different colours

When white light is used, the diffraction pattern consists of a white central maximum and on both sides continuous coloured diffraction patterns are formed. The central maximum is white as all the colours meet here constructively with no path difference. As θ increases, the path difference, $(a+b)\sin\theta$, passes through condition for maxima of

diffraction of different orders for all colours from violet to red. It produces a spectrum of diffraction pattern from violet to red on either side of central maximum as shown in Figure 6.68. By measuring the angle at which these colours appear for various orders of diffraction, the wavelength of different colours could be calculated using the formula,

$$\lambda = \frac{\sin \theta}{Nm} \quad (6.161)$$

Here, N is the number of rulings per metre in the grating and m is the order of the diffraction image.

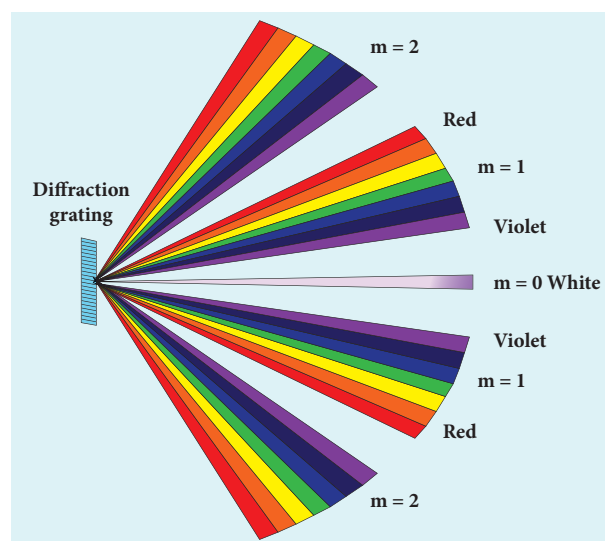

Figure 6.68 Diffraction with white light

6.11.9 Resolution

The effect of diffraction has an adverse impact in the image formation by the optical instruments such as microscope and telescope. For a single rectangular slit, the half angle θ subtended by the spread of central maximum (or position of first minimum) is given by the relation,

$$a \sin \theta = \lambda \quad (6.162)$$

Similar to a rectangular slit, when a circular aperture or opening (like a lens or the iris of our eye) forms an image of a point object, the image formed will not be a point

but a diffraction pattern of concentric circles that becomes fainter while moving away from the center as shown in Figure 6.69. These are known as Airy's discs. The circle of central maximum has the half angular spread given by the equation,

$$a \sin \theta = 1.22 \lambda \quad (6.163)$$

Here, the numerical value 1.22 comes for central maximum formed by circular apertures. This involves higher level mathematics which is avoided in this discussion.

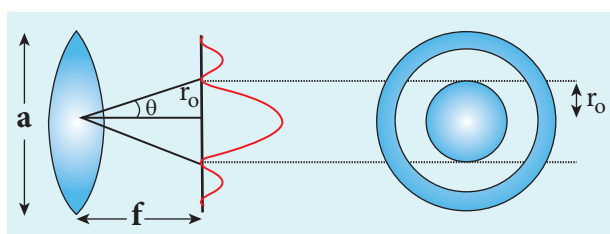

Figure 6.69 Airy's discs

For small angles, $\sin \theta \approx \theta$

$$a \theta = 1.22 \lambda \quad (6.164)$$

Rewriting further,

$$\theta = \frac{1.22 \lambda}{a} \text{ and } \frac{r_0}{f} = \frac{1.22 \lambda}{a}$$

$$r_0 = \frac{1.22 \lambda f}{a} \quad (6.165)$$

When two point sources close to each other form image on the screen, the diffraction pattern of one point source can overlap with another and produce a blurred image as shown in Figure 6.70(a). To obtain a good image of the two sources, the two point sources must be resolved i.e., the point sources must be imaged in such a way that their images are sufficiently far apart that their diffraction patterns do not overlap. According to *Rayleigh's criterion*, for two point objects to be just resolved, the

minimum distance between their diffraction images must be in such a way that the central maximum of one coincides with the first minimum of the other and vice versa as shown in Figure 6.70(b). Such an image is said to be just resolved image of the object. The Rayleigh's criterion is said to be limit of resolution.

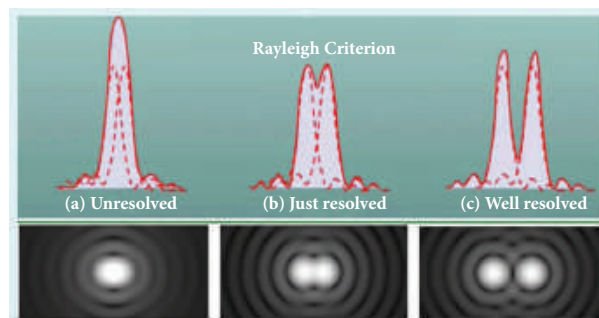

Figure 6.70 Rayleigh's criterion

According to Rayleigh's criterion the two point sources are said to be just resolved when the distance between the two maxima is at least r_0 . The **angular resolution** has a unit in radian (rad) and it is given by the equation,

$$\theta = \frac{1.22 \lambda}{a} \quad (6.166)$$

It shows that the first order diffraction angle must be as small as possible for greater resolution. This further shows that for better resolution, the wavelength of light used must be as small as possible and the size of the aperture of the instrument used must be as large as possible. The Equation 6.165 is used to calculate **spacial resolution**.

The inverse of resolution is called resolving power. This implies, smaller the resolution, greater is the resolving power of the instrument. **The ability of an optical instrument to separate or distinguish small or closely adjacent objects through the image formation is said to be resolving power of the instrument.** In general, the

term resolution is pertaining to the quality of the image formed and the term resolving power is associated with the ability of the optical instrument.

EXAMPLE 6.36

The optical telescope in the Vainu Bappu observatory at Kavalur has an objective lens of diameter 2.3 m. What is its angular resolution if the wavelength of light used is 589 nm?

Solution

$$a = 2.3 \text{ m}; \lambda = 589 \text{ nm} = 589 \times 10^{-9} \text{ m}; \theta = ?$$

The equation for angular resolution is,

$$\theta = \frac{1.22\lambda}{a}$$

Substituting,

$$\theta = \frac{1.22 \times 589 \times 10^{-9}}{2.3} = 321.4 \times 10^{-9}$$

$$\theta = 3.214 \times 10^{-7} \text{ rad} \approx 0.0011'$$

Note: The angular resolution of human eye is approximately, $3 \times 10^{-4} \text{ rad} \approx 1.03'$.

6.12 POLARISATION

The phenomena of interference and diffraction demonstrated that light is propagated in the form of waves. They did not specify whether the light waves are transverse or longitudinal. The phenomena of interference and diffraction are possible in both transverse and longitudinal waves. The phenomenon of polarization distinctly proves that light waves are only transverse in nature. Light is propagated in the form of electromagnetic waves. **The phenomenon of restricting the vibrations of light (electric or magnetic field vector)**

to a particular direction perpendicular to the direction of propagation of wave is called *polarization of light*. In this lesson only the electric field is considered for discussion.

6.12.1 Plane polarised light

A transverse wave which has vibrations in all directions in a plane perpendicular to the direction of propagation of wave is said to be *unpolarised light* as shown in Figure 6.71(a). All these vibrations could be resolved into parallel and perpendicular components as shown in Figure 6.71(b) which represents unpolarised light. **If the vibrations of a wave are present in only one direction in a plane perpendicular to the direction of propagation of wave is said to be *polarised or plane polarised light*** as shown in Figure 6.71(c) and 6.71(d).

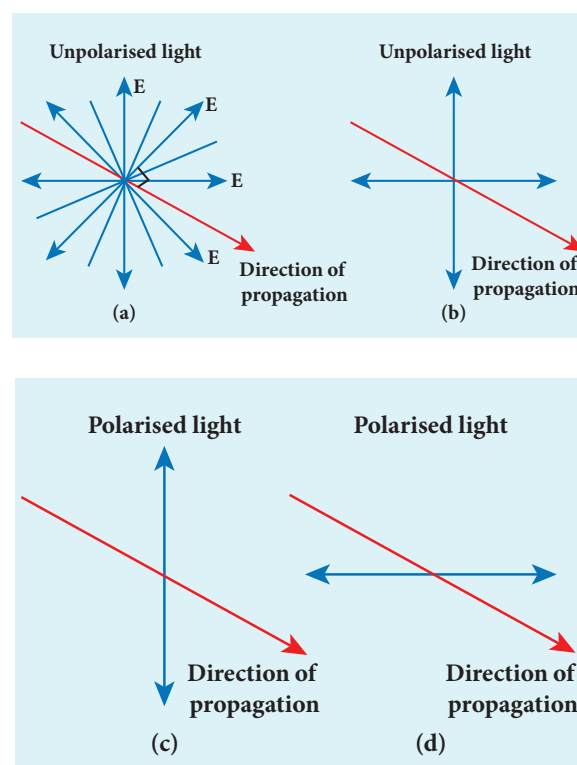

Figure 6.71 Unpolarised and polarised light

The plane containing the vibrations of the electric field vector is known as the *plane of vibration* ABCD as shown in Figure 6.72. The plane perpendicular to the plane of vibration and containing the ray of light is known as the *plane of polarisation* EFGH.

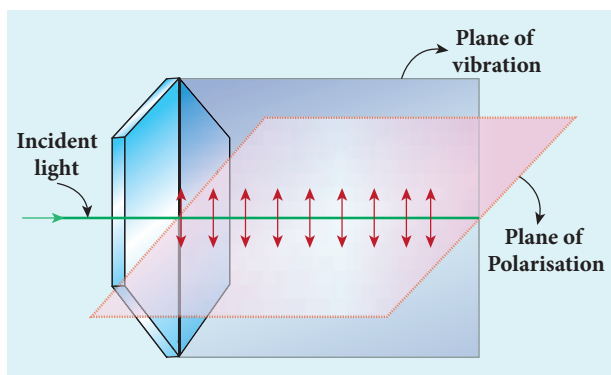

Figure 6.72 Plane of vibration and plane of polarisation

The Table 6.6 consolidates few characteristics of polarised and unpolarised light.

6.12.2 Polarisation Techniques

The unpolarised light can be polarised by several techniques. Here, we are discussing the following four methods,

- (i) polarisation by selective absorption
- (ii) polarisation by reflection
- (iii) polarisation by double refraction
- (iv) polarisation by scattering.

6.12.3 Polarisation by selective absorption

Selective absorption is the property of a material which transmits waves whose electric fields vibrate in a plane parallel to a certain direction of orientation and absorbs all other waves. The *polaroids* or *polarisers* are thin commercial sheets which make use of the property of selective absorption to produce an intense beam of plane polarised light. Selective absorption is also called as *dichroism*.

In 1932, an American scientist Edwin Land developed polarisers in the form of sheets. Tourmaline is a natural polarising material. Polaroids are also made artificially. It was discovered that small needle shaped crystals of quinine iodosulphate have the property of polarising light. A number of these crystals with their axes parallel to one another packed in between two transparent plastic sheets serve as a good polaroid. Recently new types of polaroids are prepared in which thin film of polyvinyl alcohol is used. These are colourless crystals which transmit more light, and give better polarisation. Polaroids have many applications as the one shown in Figure 6.73.

Table 6.6 Characteristics of polarised light and unpolarised light

S.No	Polarised light	Unpolarised light
1	Consists of waves having their electric field vibrations in a single plane normal to the direction of ray.	Consists of waves having their electric field vibrations equally distributed in all directions normal to the direction of ray.
2	Asymmetrical about the ray direction	Symmetrical about the ray direction
3	It is obtained from unpolarised light with the help of polarisers	Produced by conventional light sources.

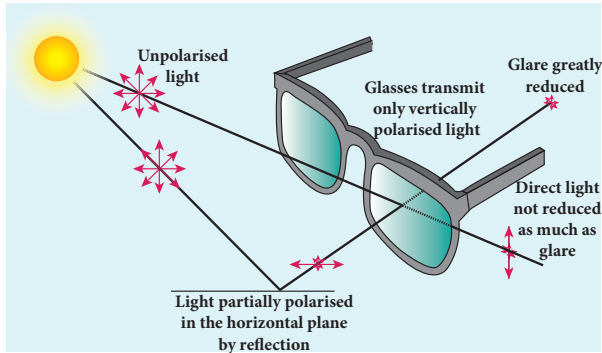

Figure 6.73 Polaroid sun glasses

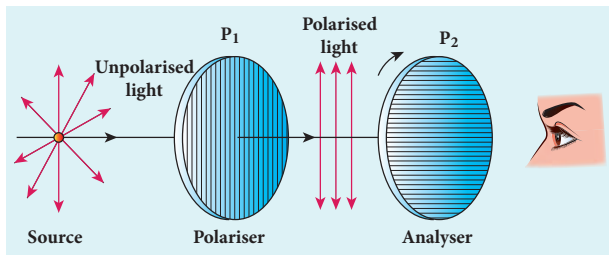

Figure 6.74 Polariser and analyser

6.12.3.1 Polariser and analyser

Let us consider an unpolarised beam of light. The vibrations can be in all possible directions all of them being perpendicular to the direction of propagation as shown in Figure 6.74. When this light passes through polaroid P_1 the vibrations are restricted to only one plane. The emergent beam can be further passed through another polaroid P_2 . If the polaroid P_2 is rotated about the ray of light as axis, for a particular position of P_2 the intensity is maximum. When the polaroid P_2 is rotated from this position the intensity starts decreasing. There is complete extinction of the light when P_2 is rotated through 90° . On further rotation of P_2 the light reappears and the intensity increases and becomes a maximum for a further rotation through 90° . The light coming out from polaroid P_1 is said to be plane polarised. The Polaroid (here P_1) which plane polarises the unpolarised

light passing through it is called a *polariser*. The polaroid (here P_2) which is used to examine whether a beam of light is polarised or not is called an *analyser*.

If the intensity of the unpolarised light is I then the intensity of plane polarised light will be $\left(\frac{I}{2}\right)$. The other half of intensity is restricted by the polariser.

6.12.3.2 Plane and partially polarised light

In *plane polarised light* the intensity varies from maximum to zero for every rotation of 90° of the analyser as shown in Figure 6.75(a). This is because the vibrations are allowed in one axis and completely restricted in the perpendicular axis. On the other hand, if the intensity of light varies between maximum and minimum for every rotation of 90° of the analyser, the light is said to be *partially polarised light* as shown in Figure 6.75(b). This is because the light is not fully restricted in that particular axis which shows a minimum intensity.

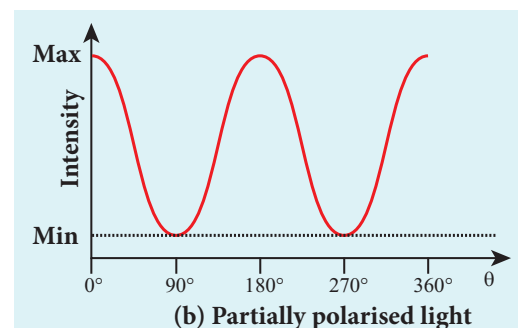
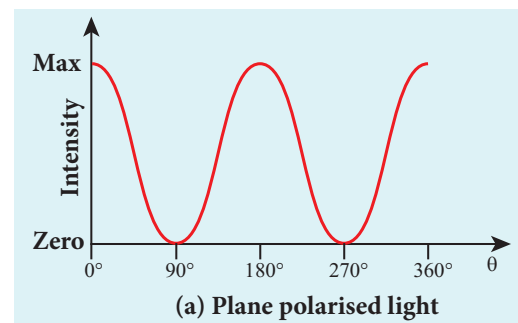

Figure 6.75 Intensity variation in plane and partially polarised light

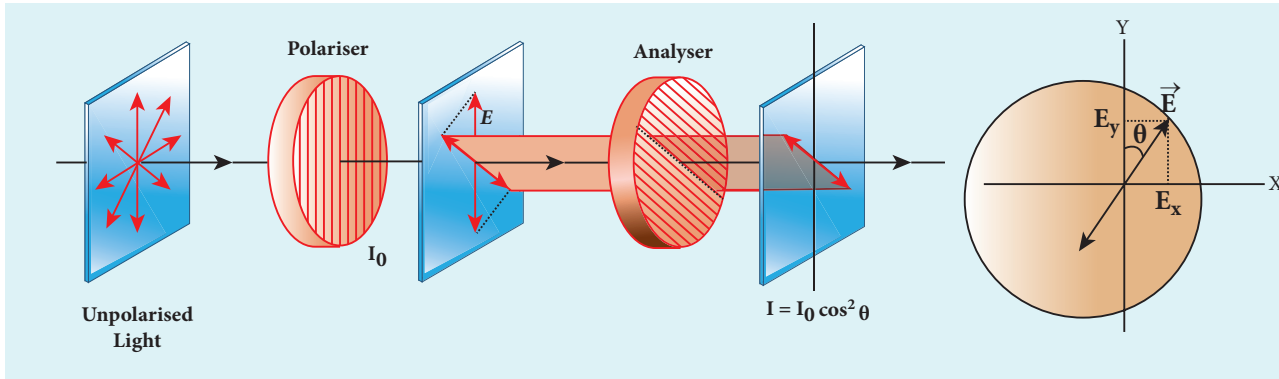

Figure 6.76 Malus's law

6.12.3.3 Malus' law

When a plane polarised light is seen through an analyser, the intensity of transmitted light varies as the analyser is rotated through an angle perpendicular to the incident direction. In 1809, French Physicist E.N Malus discovered that when a beam of plane polarised light of intensity I_0 is incident on an analyser, the light transmitted of intensity I from the analyser varies directly as the square of the cosine of the angle θ between the transmission axis of polariser and analyser as shown in Figure 6.76. This is known as Malus' law.

$$I = I_0 \cos^2 \theta \quad (6.167)$$

The proof of Malus's law is as follows. Let us consider the plane of polariser and analyser are inclined to each other at an angle θ is as shown in Figure 6.77. Let I_0 be the intensity and a be the amplitude of the electric vector transmitted by the polariser. The amplitude a of the incident light has two rectangular components, $a \cos \theta$ and $a \sin \theta$ which are the parallel and perpendicular components to the axis of transmission of the analyser.

Only the component $a \cos \theta$ will be transmitted by the analyser. The intensity of light transmitted from the analyser is proportional to the square of the component of the amplitude transmitted by the analyser.

$$I \propto (a \cos \theta)^2$$

$$I = k(a \cos \theta)^2$$

Where k is constant of proportionality.

$$I = ka^2 \cos^2 \theta$$

$$I = I_0 \cos^2 \theta$$

Where, $I_0 = ka^2$ is the maximum intensity of light transmitted from the analyser.

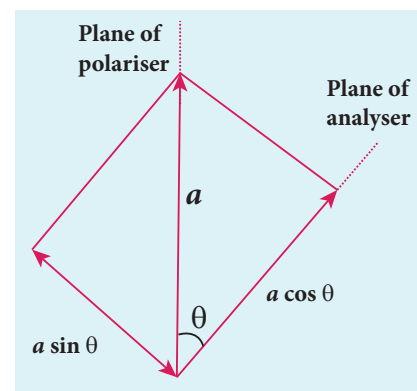

Figure 6.77 Malus' law

The following are few special cases.

Case (i) When $\theta = 0^\circ$, $\cos 0^\circ = 1$, $I = I_0$

When the transmission axis of polariser is along that of the analyser, the intensity of light transmitted from the analyser is equal to the incident light that falls on it from the polariser.

Case (ii) When $\theta = 90^\circ$, $\cos 90^\circ = 0$, $I = 0$

When the transmission axes of polariser and analyser are perpendicular to each other, the intensity of light transmitted from the analyser is zero.

EXAMPLE 6.37

Two polaroids are kept with their transmission axes inclined at 30° . Unpolarised light of intensity I falls on the first polaroid. Find out the intensity of light emerging from the second polaroid.

Solution

As the intensity of the unpolarised light falling on the first polaroid is I , the intensity of polarized light emerging will be, $I_0 = \left(\frac{I}{2}\right)$.

Let I' be the intensity of light emerging from the second polaroid.

Malus' law, $I' = I_0 \cos^2 \theta$

Substituting,

$$I' = \left(\frac{I}{2}\right) \cos^2(30^\circ) = \left(\frac{I}{2}\right) \left(\frac{\sqrt{3}}{2}\right)^2 = I \frac{3}{8}$$

$$I' = \left(\frac{3}{8}\right) I$$

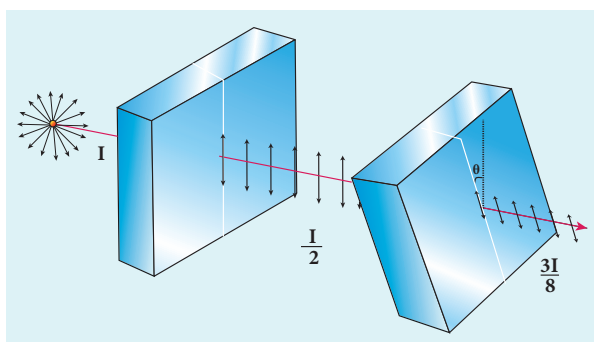

EXAMPLE 6.38

Two polaroids are kept crossed (transmission axes at 90°) to each other.

(i) What will be the intensity of the light coming out from the second polaroid when an unpolarised light of intensity I falls on the first polaroid?

(ii) What will be the intensity of light coming out from the second polaroid if a third polaroid is kept at 45° inclination to both of them.

Solution

(i) As the intensity of the unpolarised light falling on the first polaroid is I , the intensity of polarized light emerging from it will be $I_0 = \left(\frac{I}{2}\right)$. Let I' be the intensity of light emerging from the second polaroid.

Malus' law, $I' = I_0 \cos^2 \theta$

Here θ is 90° as the transmission axes are perpendicular to each other.

Substituting,

$$I' = \left(\frac{I}{2}\right) \cos^2(90^\circ) = 0 \quad [\because \cos(90^\circ) = 0]$$

No light comes out from the second polaroid.

(ii) Let the first polaroid be P_1 and the second polaroid be P_2 . They are oriented at 90° . The third polaroid P_3 is introduced between them at 45° . Let I' be the intensity of light emerging from P_3 .

Angle between P_1 and P_3 is 45° . The intensity of light coming out from P_3 is, $I' = I_0 \cos^2 \theta$

Substituting,

$$I' = \left(\frac{I}{2}\right) \cos^2(45^\circ) = \left(\frac{I}{2}\right) \left(\frac{1}{\sqrt{2}}\right)^2 = \frac{I}{4}; \quad I' = \frac{I}{4}$$

Angle between P_3 and P_2 is 45° . Let I'' is the intensity of light coming out from P_2

$$I'' = I' \cos^2 \theta$$

Here, the intensity of polarized light existing between P_3 and P_2 is $\frac{I}{4}$.

Substituting,

$$I'' = \left(\frac{I}{4}\right) \cos^2(45^\circ) = \left(\frac{I}{4}\right) \left(\frac{1}{\sqrt{2}}\right)^2 = \frac{I}{8}$$

$$I'' = \frac{I}{8}$$

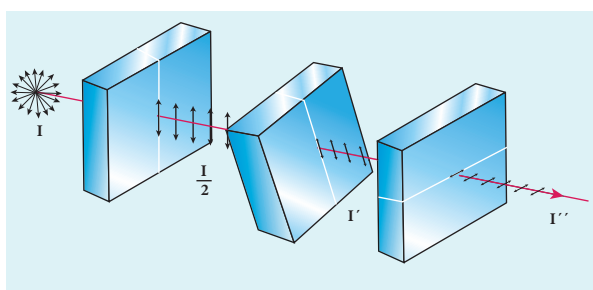

6.12.3.4. Uses of polaroids

1. Polaroids are used in goggles and cameras to avoid glare of light.
2. Polaroids are useful in three dimensional motion pictures i.e., in holography.
3. Polaroids are used to improve contrast in old oil paintings.
4. Polaroids are used in optical stress analysis.
5. Polaroids are used as window glasses to control the intensity of incoming light.
6. Polarised laser beam acts as needle to read/write in compact discs (CDs).
7. Polaroids produce polarised lights to be used in liquid crystal display (LCD).

6.12.4 Polarisation by reflection

The simplest method of producing plane polarised light is by reflection. Consider a beam of unpolarised light AB is incident at any angle on the reflecting glass surface XY .

Vibrations in AB which are parallel to the plane of the diagram are shown by arrows. The vibrations which are perpendicular to the plane of the diagram and parallel to the reflecting surface are shown by dots in Figure 6.78. A part of the light is reflected along BC , and the rest is refracted along BD . On examining the reflected beam BC with an analyser, it is found that the ray is partially plane polarised. When the light is allowed to be incident at a particular angle the reflected beam is found to be plane polarised. **The angle of incidence at which the reflected beam is plane polarised is called polarising angle i_p .**

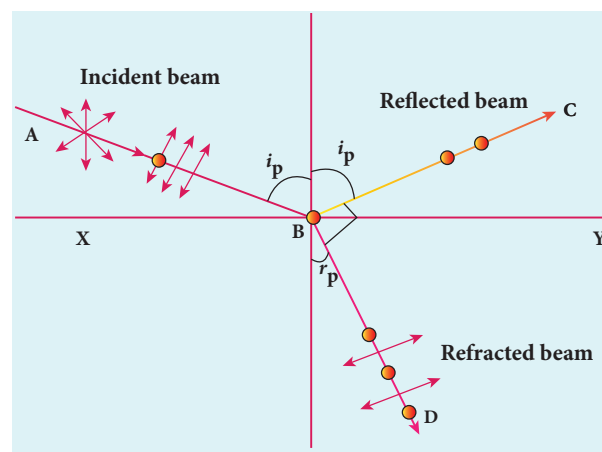

Figure 6.78 Polarisation by reflection

6.12.4.1 Brewster's Law

In 1808, Malus discovered that when ordinary light is incident on the surface of a transparent medium, the reflected light is partially plane polarised. The extent of polarisation depends on the angle of incidence. For a particular angle of incidence, the reflected light is found to be plane polarised. The angle of incidence at which a beam of unpolarised light falling on a transparent surface is reflected as a beam of plane polarised light is called *polarising angle* or *Brewster's angle*. It is denoted by i_p .

Further, the British Physicist, Sir. David Brewster found that at the incidence of polarising angle, the reflected and transmitted rays are perpendicular to each other. Suppose, i_p is the polarising angle and r_p is the corresponding angle of refraction. Then from Figure 6.82,

$$i_p + 90^\circ + r_p = 180^\circ \quad (6.168)$$

$$r_p = 90^\circ - i_p \quad (6.169)$$

From Snell's law, the refractive index of the transparent medium is,

$$\frac{\sin i_p}{\sin r_p} = n \quad (6.170)$$

where n is the refractive index of the medium with respect to air.

Substituting the value of r_p from Equation 6.163, we get,

$$\frac{\sin i_p}{\sin(90^\circ - i_p)} = \frac{\sin i_p}{\cos i_p} = n$$

$$\tan i_p = n \quad (6.171)$$

This relation is known as *Brewster's law*. The law states that the tangent of the polarising angle for a transparent medium is equal to its refractive index. The value of Brewster's angle depends on the nature of the transparent refracting medium and the wavelength of light used.

EXAMPLE 6.39

Find the polarizing angles for (i) glass of refractive index 1.5 and (ii) water of refractive index 1.33.

Solution

Brewster's law, $\tan i_p = n$

For glass, $\tan i_p = 1.5$; $i_p = \tan^{-1} 1.5$; $i_p = 56.3^\circ$

For water, $\tan i_p = 1.33$; $i_p = \tan^{-1} 1.33$; $i_p = 53.1^\circ$

6.12.4.2 Pile of plates

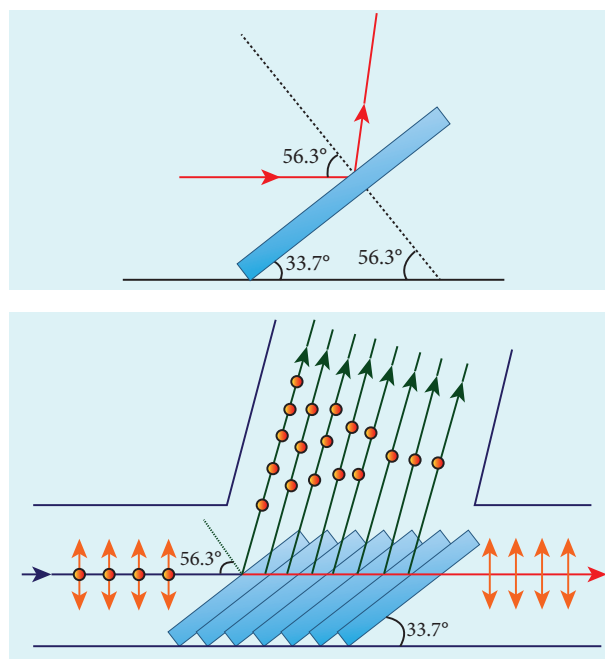

Figure 6.79 Pile of plates

The phenomenon of polarisation by reflection is used in the construction of pile of plates. It consists of a number of glass plates placed one over the other in a tube as shown in Figure 6.79. The plates are inclined at an angle of 33.7° ($90^\circ - 56.3^\circ$) to the axis of the tube. A beam of unpolarised light is allowed to fall on the pile of plates along the axis of the tube. So, the angle of incidence of light will be at 56.3° which is the polarising angle for glass. The vibrations perpendicular to the plane of incidence are reflected at each surface and those parallel to it are transmitted. The larger the number of surfaces, the greater is the intensity of the reflected plane polarised light. The pile of plates is used as a polarizer and also as an analyser.

EXAMPLE 6.40

What is the angle at which a glass plate of refractive index 1.65 is to be kept with respect to the horizontal surface so that an unpolarised light travelling horizontal after reflection from the glass plate is found to be plane polarised?

Solution

$$n = 1.65$$

Brewster's law, $\tan i_p = n$

$$\tan i_p = 1.65; i_p = \tan^{-1} 1.65; i_p = 58.8^\circ$$

The inclination with the horizontal surface is, $(90^\circ - 58.8^\circ) = 31.2^\circ$

laws of refraction, called as extraordinary rays. The extraordinary ray is found to be plane polarised. Inside a double refracting crystal the ordinary ray travels with same velocity in all directions and the extraordinary ray travels with different velocities along different directions. A point source inside a refracting crystal produces spherical wavefront corresponding to ordinary ray and elliptical wavefront corresponding to extraordinary ray. Inside the crystal, there is a particular direction in which both the rays travel with same velocity. This direction is called *optic axis*. Along the optic axis, the refractive index is same for both the rays and there is no double refraction along this direction.

6.12.5 Polarisation by double refraction

Erasmus Bartholinus, a Danish physicist discovered that when a ray of unpolarised light is incident on a calcite crystal, two refracted rays are produced. Hence, two images of a single object are formed. This phenomenon is called *double refraction* as shown in Figure 6.80. Double refraction is also called *birefringence*. This phenomenon is also exhibited by several other crystals like quartz, mica etc.

When an ink dot on a sheet of paper is viewed through a calcite crystal, two images will be seen. On rotating the crystal, one image remains stationary, while the other rotates around the first. The stationary image is known as the ordinary image *O*, produced by the refracted rays which obey the laws of refraction, called as ordinary rays. The other image is extraordinary image *E*, produced by the refracted rays which do not obey the

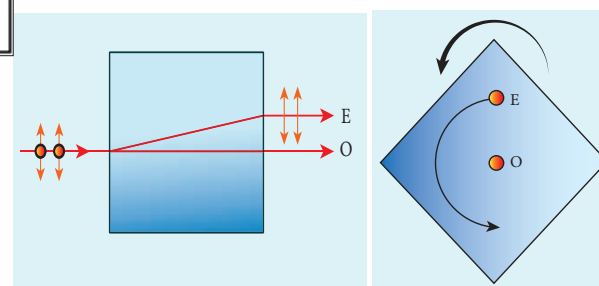
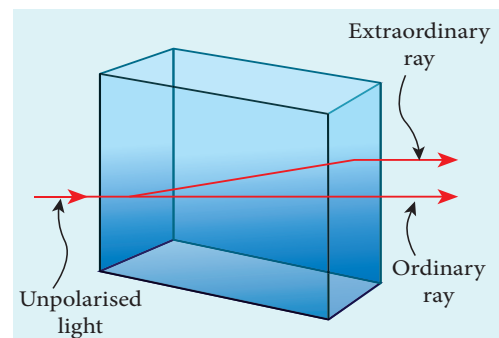

Figure 6.80 Double refraction

6.12.6 Types of optically active crystals

Crystals like calcite, quartz, tourmaline and ice having only one optic axis are called uniaxial crystals.

Crystals like mica, topaz, selenite and aragonite having two optic axes are called biaxial crystals.

6.12.7 Nicol prism

Nicol prism is an optical device incorporated in optical instruments both for producing and analysing plane polarised light. The construction of a Nicol prism is based on the phenomenon of Double refraction and was designed by William Nicol in 1828.

One of the most common forms of the Nicol prism is made by taking a calcite crystal which is a double refracting crystal with its length three times its breadth. As shown in Figure 6.81, $ABCD$ represents the principal section of a calcite crystal. It is cut into two halves along the diagonal so that their face angles are 72° and 108° . The two halves are joined together by a layer of *canada balsam*, a transparent cement.

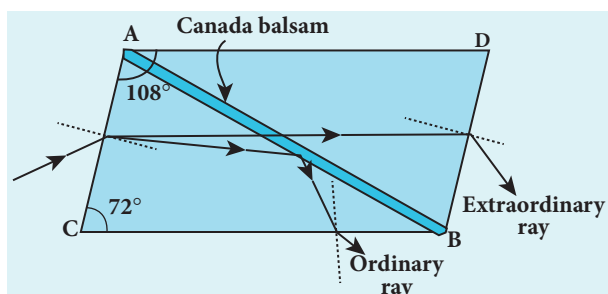

Figure 6.81 Nicol Prism

Let us consider a ray of unpolarised light from monochromatic source such as a sodium vapour lamp is incident on the face AC of the Nicol prism. Double refraction takes place and the ray is split into ordinary and extraordinary rays. They travel with different velocities. The refractive index of the crystal for the ordinary ray (monochromatic sodium light) is 1.658 and for extraordinary ray is 1.486. The refractive index of *canada balsam* is 1.523. *Canada balsam* does not polarise light.

The ordinary ray is total internally reflected at the layer of *canada balsam* and is prevented from emerging from the

other face. The extraordinary ray alone is transmitted through the crystal which is plane polarised.

Uses of Nicol prism

- (i) It produces plane polarised light and functions as a polariser
- (ii) It can also be used to analyse the plane polarised light i.e used at an analyser.

Drawbacks of Nicol prism

- (i) Its cost is very high due to scarcity of large and flawless calcite crystals
- (ii) Due to extraordinary ray passing obliquely through it, the emergent ray is always displaced a little to one side.
- (iii) The effective field of view is quite limited
- (iv) Light emerging out of it is not uniformly plane polarised.

6.12.8 Polarisation by scattering

The light from a clear blue portion of the sky shows a rise and fall of intensity when viewed through a polaroid which is rotated. This is because of sunlight, which has changed its direction (having been scattered) on encountering the molecules of the earth's atmosphere. As Figure 6.81 shows, the incident sunlight is unpolarised. The electric field of light interact with the electrons present in the air molecules. Under the influence of the electric field of the incident wave the electrons in the molecules acquire components of motion in both these directions. We have shown an observer looking at 90° to the direction of the sun. Clearly, charges accelerating parallel do not radiate energy towards this observer since their acceleration has no transverse component. The radiation scattered by the molecule is therefore

polarized perpendicular to the plane of the Figure 6.82. This explains the reason for polarisation of sunlight by scattering.

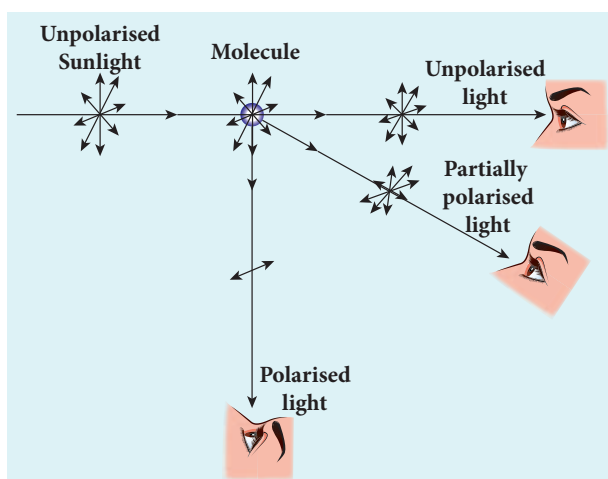

Figure 6.82 Polarisation by scattering

6.13

OPTICAL INSTRUMENTS

There are plenty of optical instruments we used in our daily life. We shall discuss here about microscopes, telescopes, spectrometer and of course human eye.

6.13.1 Simple microscope

A simple microscope is a single magnifying (converging) lens of small focal length. The idea is to get an erect, magnified and virtual image of the object. For this the object is placed between F and P on one side of the lens and viewed from other side of the lens. There are two magnifications to be discussed for two kinds of focussing.

(1) *Near point focusing* – The image is formed at near point, i.e. 25 cm for normal eye. This distance is also called as *least distance D* of distinct vision. In this position, the eye feels comfortable but there is little strain on the eye. This is shown in Figure 6.83

(2) *Normal focusing* – The image is formed at infinity. In this position the eye is most relaxed to view the image. This is shown in Figure 6.84(b).

6.13.1.1 Magnification in near point focusing

The near point focusing is shown in Figure 6.83. Object distance u is less than f . The image distance is the near point D . The magnification m is given by the relation,

$$m = \frac{v}{u} \quad (6.172)$$

With the help of lens equation, $\frac{1}{v} - \frac{1}{u} = \frac{1}{f}$ the magnification can further be written as,

$$m = 1 - \frac{v}{f} \quad (6.173)$$

Substituting for v with sign convention, $v = -D$

$$m = 1 + \frac{D}{f} \quad (6.174)$$

This is the magnification for near point focusing.

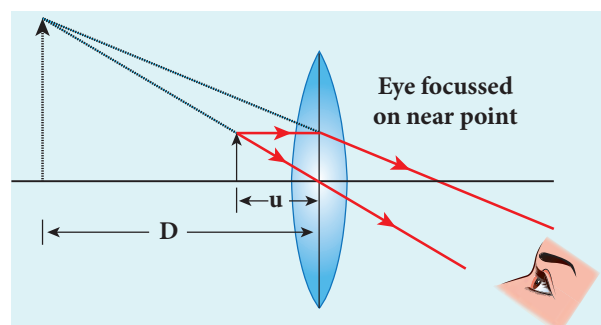

Figure 6.83 Near point focusing

6.13.1.2 Magnification in normal focusing (angular magnification)

The normal focusing is shown in Figure 6.84(b). We will now find the magnification for the image formed at infinity. If we take the ratio of height of image to height of

object $\left(m = \frac{h'}{h}\right)$ to find the magnification, we will not get a practical relation, as the image will also be of infinite size when the image is formed at infinity. Hence, we can practically use the angular magnification. The angular magnification is defined as the ratio of angle θ_i subtended by the image with aided eye to the angle θ_0 subtended by the object with unaided eye.

$$m = \frac{\theta_i}{\theta_0} \quad (6.175)$$

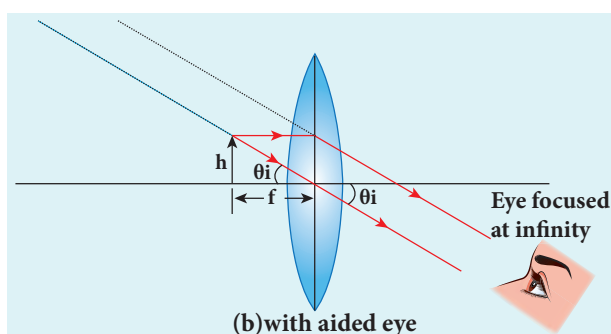
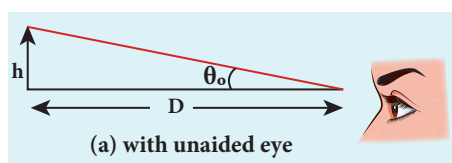

Figure 6.84 Normal focusing

For unaided eye shown in Figure 6.84(a),

$$\tan \theta_0 \approx \theta_0 = \frac{h}{D} \quad (6.176)$$

For aided eye shown in Figure 6.83(b),

$$\tan \theta_i \approx \theta_i = \frac{h}{f} \quad (6.177)$$

The angular magnification is,

$$m = \frac{\theta_i}{\theta_0} = \frac{h/f}{h/D}$$

$$m = \frac{D}{f} \quad (6.178)$$

This is the magnification for normal focusing.

The magnification for normal focusing is one less than that for near point focusing. But, the viewing is more comfortable in normal focusing than near point focusing. For large values of D/f , the difference in magnification is usually small. In subsequent discussions, we shall only consider the normal focusing.

EXAMPLE 6.41

A man with a near point of 25 cm reads a book with small print using a magnifying glass, a convex lens of focal length 5 cm. (a) What is the closest and the farthest distance at which he should keep the lens from the page so that he can read the book when viewing through the magnifying glass? (b) What is the maximum and the minimum angular magnification (magnifying power) possible using the above simple microscope?

Solution

$$D = 25 \text{ cm}; f = 5 \text{ cm};$$

For closest object distance, u ; the image distance, v is, -25 cm. (near point focusing)

For farthest object distance, u' ; the corresponding image distance, v' is, $v' = \infty$ (normal focusing)

(a) To find closest image distance, lens equation, $\frac{1}{v} - \frac{1}{u} = \frac{1}{f}$

Rewriting for closest object distance, $\frac{1}{u} = \frac{1}{v} - \frac{1}{f}$

Substituting,

$$\frac{1}{u} = \frac{1}{-25} - \frac{1}{5} = \frac{1}{25} - \frac{1}{5} = \left(\frac{-1-5}{25}\right) = -\frac{6}{25}$$

$$u = -\frac{25}{6} = -4.167 \text{ cm}$$

The closest distance at which the person should can keep the book is, $u = -4.167 \text{ cm}$

To find farthest object distance, lens equation is, $\frac{1}{v'} - \frac{1}{u'} = \frac{1}{f'}$

Rewriting for farthest object distance, $\frac{1}{u'} = \frac{1}{v'} - \frac{1}{f'}$

Substituting, $\frac{1}{u'} = \frac{1}{\infty} - \frac{1}{5}; u = -5 \text{ cm}$

The farthest distance at which the person can keep the book is, $u' = -5 \text{ cm}$

(b) To find magnification in near point focusing, $m = 1 + \frac{D}{f} = 1 + \frac{25}{5} = 6$

To find magnification in normal focusing, $m = \frac{D}{f} = \frac{25}{5} = 5$

6.13.1.3. Resolving power of microscope

The diagram related to the calculation of resolution of microscope is illustrated in Figure 6.85. A microscope is used to see the details of the object under observation. The ability of microscope depends not only in magnifying the object but also in resolving two points on the object separated by a small distance d_{min} . Smaller the value of d_{min} better will be the resolving power of the microscope.

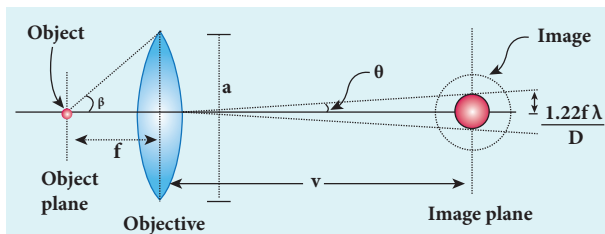

Figure 6.85 Resolving power of microscope

The radius of central maxima is already derived as equation 6.159,

$$r_o = \frac{1.22\lambda v}{a} \quad (6.179)$$

In the place of focal length f we have the image distance v . If the difference between the two points on the object to be resolved is d_{min} , then the magnification m is,

$$m = \frac{r_o}{d_{min}} \quad (6.180)$$

$$d_{min} = \frac{r_o}{m} = \frac{1.22\lambda v}{am} = \frac{1.22\lambda v}{a(v/u)} = \frac{1.22\lambda u}{a} [\because m = v/u]$$

$$d_{min} = \frac{1.22\lambda f}{a} [\because u \approx f] \quad (6.181)$$

On the object side,

$$2 \tan \beta \approx 2 \sin \beta = \frac{a}{f} \therefore [a = f 2 \sin \beta] \quad (6.182)$$

$$d_{min} = \frac{1.22\lambda}{2 \sin \beta} \quad (6.183)$$

To further reduce the value of d_{min} the optical path of the light is increased by immersing the objective of the microscope in to a bath containing oil of refractive index n .

$$d_{min} = \frac{1.22\lambda}{2n \sin \beta} \quad (6.184)$$

Such an objective is called oil immersed objective. **The term $n \sin \beta$ is called numerical aperture NA.**

$$d_{min} = \frac{1.22\lambda}{2(NA)} \quad (6.185)$$

6.13.2 Compound microscope

The diagram of a compound microscope is shown in Figure 6.86. The lens near the

object, called the **objective**, forms a real, inverted, magnified image of the object. This serves as the object for the second lens which is the **eyepiece**. Eyepiece serves as a simple microscope that produces finally an enlarged and virtual image. The first inverted image formed by the objective is to be adjusted close to, but within the focal plane of the eyepiece so that the final image is formed nearly at infinity or at the near point. The final image is inverted with respect to the original object. We can obtain the magnification for a compound microscope.

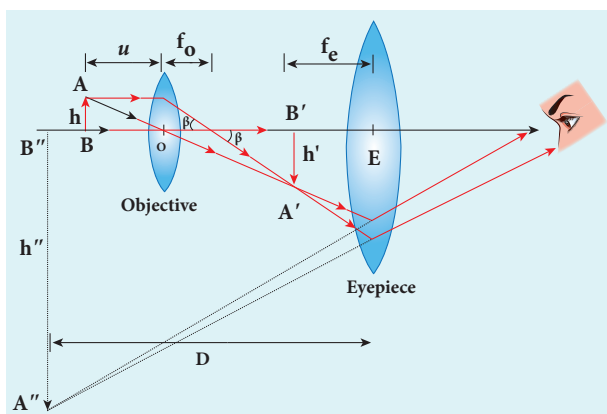

Figure 6.86 Compound microscope

6.13.2.1. Magnification of compound microscope

From the ray diagram, the linear magnification due to the objective is,

$$m_o = \frac{h'}{h} \quad (6.186)$$

From the Figure 6.85, $\tan \beta = \frac{h}{f_o} = \frac{h'}{L}$, then

$$\frac{h'}{h} = \frac{L}{f_o} \quad (6.187)$$

$$m_o = \frac{L}{f_o} \quad (6.188)$$

Here, the distance L is between the first focal point of the eyepiece to the second focal point of the objective. This is called the tube length L of the microscope as f_o and f_e are comparatively smaller than L .

If the final image is formed at P (near point focussing), the magnification m_e of the eyepiece is,

$$m_e = 1 + \frac{D}{f_e} \quad (6.189)$$

The total magnification m in near point focusing is,

$$m = m_o m_e = \left(\frac{L}{f_o}\right) \left(1 + \frac{D}{f_e}\right) \quad (6.190)$$

If the final image is formed at infinity (normal focusing), the magnification m_e of the eyepiece is,

$$m_e = \frac{D}{f_e} \quad (6.191)$$

The total magnification m in normal focusing is,

$$m = m_o m_e = \left(\frac{L}{f_o}\right) \left(\frac{D}{f_e}\right) \quad (6.192)$$

EXAMPLE 6.42

A microscope has an objective and eyepiece of focal lengths 5 cm and 50 cm respectively with tube length 30 cm. Find the magnification of the microscope in the (i) near point and (ii) normal focusing.

Solution

$$f_o = 5\text{cm} = 5 \times 10^{-2}\text{m}; \quad f_e = 50\text{cm} = 50 \times 10^{-2}\text{m};$$

$$L = 30\text{cm} = 30 \times 10^{-2}\text{m}; \quad D = 25\text{cm} = 25 \times 10^{-2}\text{m}$$

(i) The total magnification m in near point focusing is, $m = m_o m_e = \left(\frac{L}{f_o}\right) \left(1 + \frac{D}{f_e}\right)$

Substituting,

$$m = m_o m_e = \left(\frac{30 \times 10^{-2}}{5 \times 10^{-2}} \right) \left(1 + \frac{25 \times 10^{-2}}{50 \times 10^{-2}} \right)$$

$$= (6)(1.5) = 9$$

(ii) The total magnification m in normal focusing is, $m = m_o m_e = \left(\frac{L}{f_o} \right) \left(\frac{D}{f_e} \right)$

Substituting,

$$m = m_o m_e = \left(\frac{30 \times 10^{-2}}{5 \times 10^{-2}} \right) \left(\frac{25 \times 10^{-2}}{50 \times 10^{-2}} \right)$$

$$= (6)(0.5) = 3$$

6.13.3 Astronomical telescope

An astronomical telescope is used to get the magnification of distant astronomical objects like stars, planets, moon etc. The image formed by astronomical telescope will be inverted. It has an objective of long focal length and a much larger aperture than the eyepiece as shown in Figure 6.87. Light from a distant object enters the objective and a real image is formed in the tube at its second focal point. The eyepiece magnifies this image producing a final inverted image.

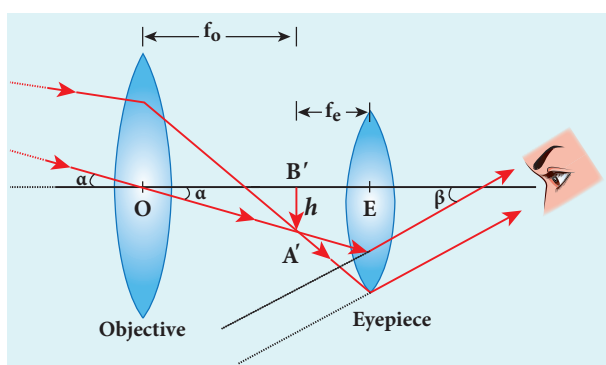

Figure 6.87 Astronomical telescope

6.13.3.1 Magnification of astronomical telescope

The magnification m is the ratio of the angle β subtended at the eye by the final

image to the angle α which the object subtends at the lens or the eye.

$$m = \frac{\beta}{\alpha} \quad (6.193)$$

$$\text{From the diagram, } m = \frac{h/f_e}{h/f_o} \quad (6.194)$$

$$m = \frac{f_o}{f_e} \quad (6.195)$$

The length of the telescope is approximately, $L = f_o + f_e$

EXAMPLE 6.43

A small telescope has an objective lens of focal length 125 cm and an eyepiece of focal length 2 cm. What is the magnification of the telescope? What is the separation between the objective and the eyepiece? Two stars separated by $1'$ will appear at what separation when viewed through the telescope?

Solution

$$f_o = 125 \text{ cm}; f_e = 2 \text{ cm}; m = ?; L = ?; \theta_i = ?$$

Equation for magnification of telescope,

$$m = \frac{f_o}{f_e}$$

$$\text{Substituting, } m = \frac{125}{2} = 62.5$$

Equation for approximate length of telescope, $L = f_o + f_e$

$$\text{Substituting, } L = 125 + 2 = 127 \text{ cm} = 1.27 \text{ m}$$

$$\text{Equation for angular magnification, } m = \frac{\theta_i}{\theta_o}$$

$$\text{Rewriting, } \theta_i = m \times \theta_o$$

Substituting,

$$\theta_i = 62.5 \times 1' = 62.5' = \frac{62.5}{60} = 1.04^\circ$$

6.13.4 Terrestrial telescope

A terrestrial telescope is used to see object at long distance on the surface of earth. Hence, image should be erect. A terrestrial telescope has an additional erecting lens to make the final image erect as shown in Figure 6.88.

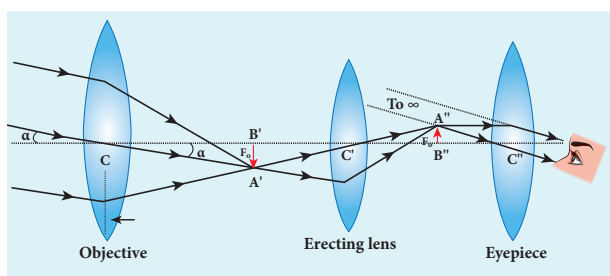

Figure 6.88 Terrestrial telescope

6.13.5 Reflecting telescope

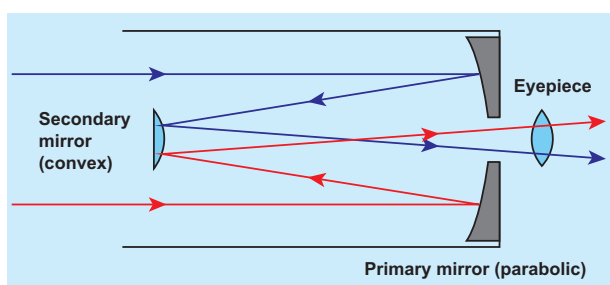

Figure 6.89 Reflecting telescope

Modern telescopes use a concave mirror rather than a lens for the objective. It is rather difficult and expensive to make lenses of large size which form images that are free from any optical defect. **Telescopes with mirror objectives are called reflecting telescopes.** They have several advantages. Only one surface it to be polished and maintained. Support can be given from the entire back of the mirror rather than only at the rim for lens. Mirrors weigh much less compared to lens. But the one obvious problem with a reflecting telescope is that the objective mirror would focus the light inside the telescope tube. One must have

an eye piece inside obstructing some light. This problem could also be overcome by introducing a secondary mirror which would take the light outside the tube for view as shown in the Figure 6.89.

6.13.6 Spectrometer

The spectrometer is an optical instrument used to study the spectra of different sources of light and to measure the refractive indices of materials. It is shown in Figure 6.90. It consists of basically three parts. They are (i) collimator (ii) prism table and (iii) Telescope.



Figure 6.90 Spectrometer

(i) Collimator

The collimator is an arrangement to produce a parallel beam of light. It consists of a long cylindrical tube with a convex lens at the inner end and a vertical slit at the outer end of the tube. The distance between the slit and the lens can be adjusted such that the slit is at the focus of the lens. The slit is kept facing the source of light. The width of the slit can be adjusted. The collimator is rigidly fixed to the base of the instrument.

(ii) Prism table

The prism table is used for mounting the prism, grating etc. It consists of two circular metal discs provided with three levelling screws. It can be rotated about a vertical axis passing through its centre and its position

can be read with verniers V_1 and V_2 . The prism table can be raised or lowered and can be fixed at any desired height.

(iii) Telescope

The telescope is an astronomical type. It consists of an eyepiece provided with cross wires at one end and an objective lens at its other end. The distance between the objective lens and the eyepiece can be adjusted so that the telescope forms a clear image at the cross wires, when a parallel beam from the collimator is incident on it.

The telescope is attached to an arm which is capable of rotation about the same vertical axis as the prism table. A circular scale graduated in half degree is attached to it. Both the telescope and prism table are provided with radial screws for fixing them in a desired position and tangential screws for fine adjustments.

Adjustments of the spectrometer

The following adjustments must be made before doing the experiment using spectrometer.

(a) **Adjustment of the eyepiece** The telescope is turned towards an illuminated surface and the eyepiece is moved to and fro until the cross wires are clearly seen.

(b) **Adjustment of the telescope** The telescope is adjusted to receive parallel rays by turning it towards a distant object and adjusting the distance between the objective lens and the eyepiece to get a clear image on the cross wire.

(c) **Adjustment of the collimator** The telescope is brought along the axial line with the collimator. The slit of the collimator is illuminated by a source of light. The distance between the slit and the lens of the collimator is adjusted until a clear image of the slit is seen at

the cross wire of the telescope. Since the telescope is already adjusted for parallel rays, a well-defined image of the slit can be formed, only when the light rays emerging from the collimator are parallel.

(d) **Levelling the prism table** The prism table is adjusted or levelled to be in horizontal position by means of levelling screws and a spirit level.

6.13.6.1 Determination of refractive index of material of the prism

The preliminary adjustments of the telescope, collimator and the prism table of the spectrometer are made. The refractive index of the prism can be determined by knowing the angle of the prism and the angle of minimum deviation.

(i) Angle of the prism (A)

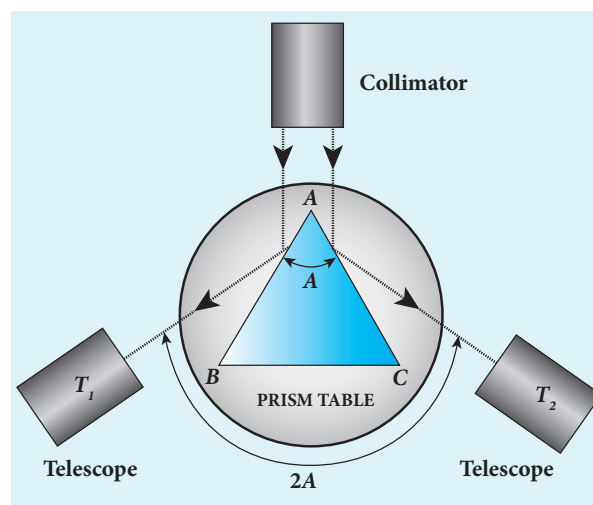

Figure 6.91 Angle of prism

The prism is placed on the prism table with its refracting edge facing the collimator as shown in Figure 6.91. The slit is illuminated by a sodium light (monochromatic light). The parallel rays coming from the collimator fall on the two faces AB and AC . The telescope is rotated to the position T_1 until the image of the slit formed by the reflection at the face AB is made to coincide

with the vertical cross wire of the telescope. The readings of the verniers are noted. The telescope is then rotated to the position T_2 where the image of the slit formed by the reflection at the face AC coincides with the vertical cross wire. The readings are again noted.

The difference between these two readings gives the angle rotated by the telescope, which is twice the angle of the prism. Half of this value gives the angle of the prism A .

(ii) Angle of minimum deviation (D)

The prism is placed on the prism table so that the light from the collimator falls on a refracting face, and the refracted image is observed through the telescope as shown in Figure 6.92. The prism table is now rotated so that the angle of deviation decreases. A stage comes when the image stops for a moment and if we rotate the prism table further in the same direction, the image is seen to recede and the angle of deviation increases. The vertical cross wire of the telescope is made to coincide with the image of the slit where it turns back. This gives the minimum deviation position.

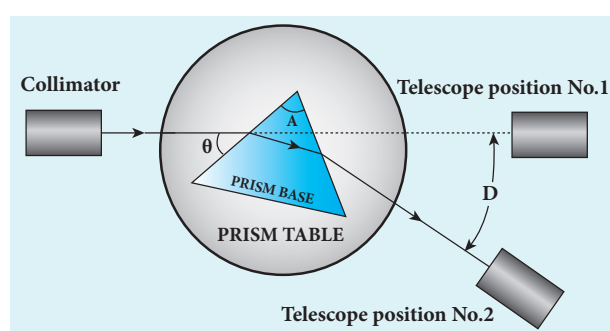

Figure 6.92 Angle of minimum deviation

The readings of the verniers are noted. Now, the prism is removed and the telescope is turned to receive the direct ray and the vertical cross wire is made to coincide with the

image. The readings of the verniers are noted. The difference between the two readings gives the angle of minimum deviation D . The refractive index of the material of the prism n is calculated using the formula,

$$n = \frac{\sin\left(\frac{A+D}{2}\right)}{\sin\left(\frac{A}{2}\right)} \quad (6.103)$$

The refractive index of a liquid may be determined in the same way using a hollow glass prism filled with the given liquid. Spectrometer experiments are discussed in the Practicals given in Volume 1 of this book.

6.13.7 The eye

Eye is a natural optical instrument given by God to the human beings. The internal structure and the Physics aspect of the functioning of different parts of human eye are discussed already in (X Physics Unit-2). As the eye lens is flexible, its focal length can be changed to some extent. When the eye is fully relaxed, the focal length is maximum and when it is strained the focal length is minimum. The image must be formed on the retina for a clear vision. The diameter of eye for a normal adult is about 2.5 cm. Hence, the image-distance, in other words, the distance between eye lens and retina is fixed always at 2.5 cm for a normal eye. We can just discuss the optical functioning of eye without giving importance to the refractive indices of the two liquids, aqueous humor and vitreous humor present in the eye. A person with normal vision can see objects kept at infinity in the relaxed condition with maximum focal length f_{max} of the eye as shown in Figure 6.93(a). Also at a distance of 25 cm in the strained condition

with minimum focal length f_{min} of the eye as shown in Figure 6.93(b).

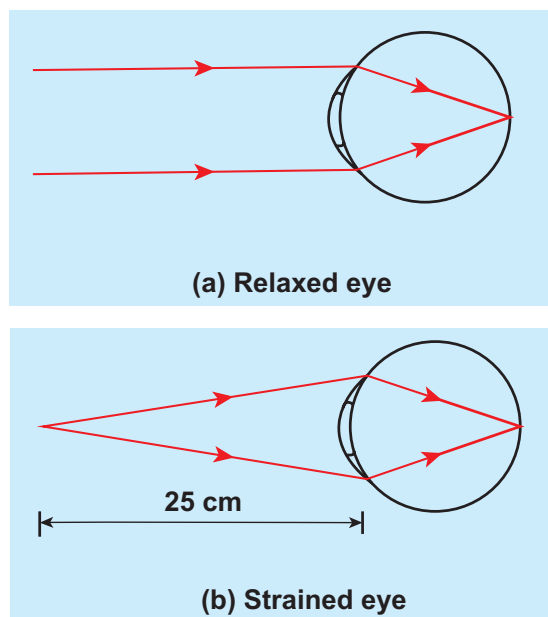

Figure 6.93 Focusing of normal eye

Let us find f_{max} and f_{min} of human eye from the lens equation given below.

$$\frac{1}{f} = \frac{1}{v} - \frac{1}{u} \quad (6.69)$$

When the object is at infinity, $u = -\infty$, and $v = 2.5$ cm (distance between eye lens and retina), the eye can see the object in relaxed condition with f_{max} . Substituting these values in the lens equation gives,

$$\frac{1}{f_{max}} = \frac{1}{2.5 \text{ cm}} - \frac{1}{-\infty}$$

$$f_{max} = 2.5 \text{ cm}$$

When the object is at near point, $u = -25$ cm, and $v = 2.5$ cm, the eye can see the object in strained condition with f_{min} . Substituting these values in the lens equation gives,

$$\frac{1}{f_{min}} = \frac{1}{2.5 \text{ cm}} - \frac{1}{-25 \text{ cm}}$$

$$f_{min} = 2.27 \text{ cm}$$

See, the small variation of $f_{max} - f_{min} = 0.23 \text{ cm}$ of the focal length of eye lens makes objects visible from infinity to near point for a normal person. Now, we can discuss some common defects of vision in the eye.

6.13.7.1 Nearsightedness (*myopia*)

A person suffering from nearsightedness or *myopia* cannot see distant objects clearly. This may result because the lens has too short focal length due to thickening of the lens or larger diameter of the eyeball than usual. These people have difficulty in relaxing their eye more than what is needed to overcome this difficulty. Thus, they need correcting lens.

The parallel rays coming from the distant object get focused before reaching the retina as shown in Figure 6.94(a). But, these persons can see objects which are nearer. Let x be the maximum distance up to which a person with nearsightedness can see as shown in Figure 6.94(b). To overcome this difficulty, the virtual image of the object at infinity should be formed at a distance x from the eye using a correcting lens as shown in Figure 6.93(c).

The focal length of the correcting lens for a myopic eye can be calculated using the lens equation.

$$\frac{1}{f} = \frac{1}{v} - \frac{1}{u} \quad (6.69)$$

Here, $u = -\infty$, $v = -x$. Substituting these values in the lens equation gives,

$$\frac{1}{f} = \frac{1}{-x} - \frac{1}{-\infty}$$

Focal length f of the correcting lens is,

$$f = -x \quad (6.196)$$

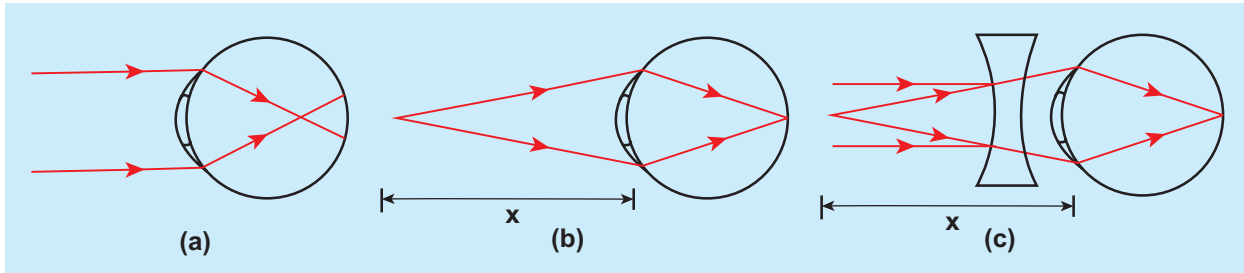

Figure 6.94 Myopic eye and correction

The negative sign in the above result suggests that the lens should be a concave lens. Basically, the concave lens slightly diverges the parallel rays from infinity and makes them focus now at the retina which got earlier focused before reaching retina in the unaided condition.

6.13.7.2 Farsightedness (*hypermetropia*)

A person suffering from farsightedness or *hypermetropia* or *hyperopia* cannot clearly see objects close to the eye. It occurs when the eye lens has too long focal length due to thinning of eye lens or shortening of the eyeball than normal. The least distance for clear vision for these people is appreciably more than 25 cm and the person has to keep the object inconveniently away from the eye. Thus, reading or viewing smaller things held in the hands is difficult for them. This kind of farsightedness arising due to aging is called *presbyopia* as the aged people cannot strain their eye more to reduce the focal length of the eye lens.

The rays coming from the object at near point get focused beyond the retina as shown in Figure 6.95(a). But, these persons can see objects which are far say, more than 25 cm. Let y be the minimum distance from the eye beyond which a person with farsightedness can see as shown in Figure 6.95(b). To overcome this difficulty, the virtual image of the object at y should be formed at a distance of 25 cm (near point) from the eye using a correcting lens as shown in Figure 6.95(c).

The focal length of the correcting lens for a hypermetropic eye can be calculated using the lens equation.

$$\frac{1}{f} = \frac{1}{v} - \frac{1}{u} \quad (6.69)$$

Here, $u = -y$, $v = -25$ cm. Substituting these values in the lens equation gives,

$$\frac{1}{f} = \frac{1}{-25} - \frac{1}{-y}$$

Simplifying the above equation gives,

$$\frac{1}{f} = \frac{1}{25} - \frac{1}{y} = \frac{y - 25}{y \times 25}$$

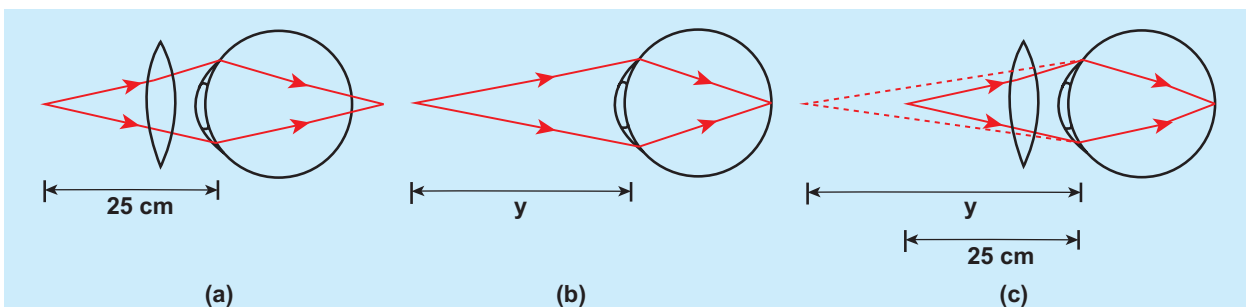

Figure 6.95 Hypermetropic eye and correction



$$f = \frac{y \times 25 \text{ cm}}{y - 25 \text{ cm}} \quad (6.197)$$

The focal length calculated using above formula will be positive as y is always greater than 25 cm. The positive sign of the focal length suggests that the lens should be a convex lens. In principle, the convex lens slightly converges the rays coming from beyond y and makes them focus now at the retina which got earlier focused beyond retina for the unaided eye.

6.13.6.3 Astigmatism

Astigmatism is the defect arising due to different curvatures along different planes in the *eye* lens. Astigmatic person cannot see all the directions equally well. The defect due to astigmatism is more serious than myopia and hyperopia. The remedy to astigmatism is using of lenses with different curvatures in different planes to rectify the defect. In general, these specially made glasses with different curvature for different planes are called as cylindrical lenses.

Due to aging people may develop combination of more than one defect. If it is the combination of nearsightedness and farsightedness then, such persons may need a converging glass for reading purpose and a diverging glass for seeing at a distance. Bifocal lenses and progressive lenses provide solution for these problems.

EXAMPLE 6.44

Calculate the power of the lens of the spectacles necessary to rectify the defect of nearsightedness for a person who could see clearly only up to a distance of 1.8 m.

Solution

The maximum distance the person could see is, $x = 1.8 \text{ m}$.

The lens should have a focal length of, $f = -x \text{ m} = -1.8 \text{ m}$.

It is a concave or diverging lens.

The power of the lens is,

$$P = -\frac{1}{1.8 \text{ m}} = -0.56 \text{ diopter}$$

EXAMPLE 6.45

A person has farsightedness with the minimum distance he could see clearly is 75 cm. Calculate the power of the lens of the spectacles necessary to rectify the defect.

Solution

The minimum distance the person could see clearly is, $y = 75 \text{ cm}$.

The lens should have a focal length of,

$$f = \frac{y \times 25 \text{ cm}}{y - 25 \text{ cm}}$$

$$f = \frac{75 \text{ cm} \times 25 \text{ cm}}{75 \text{ cm} - 25 \text{ cm}} = 37.5 \text{ cm}$$

It is a convex or converging lens.

The power of the lens is,

$$P = \frac{1}{0.375 \text{ m}} = 2.67 \text{ diopter}$$

SUMMARY

- In ray optics, light is treated as a ray in the direction of light.
- Light undergoes reflection at polished surfaces and it is governed by laws of reflection.
- In general, plane mirrors form virtual and laterally inverted images at equal distance inside the mirror.
- The height of plane mirror needed to see a person fully in a mirror is half of the height of person.
- Spherical mirrors form a part of a sphere.
- Paraxial rays are the rays travelling close to the principal axis of the mirror and make small angles with it.
- There is a relation between f and R in spherical mirrors for paraxial rays.
- Image formation in spherical mirrors is based on mirror equation.
- There is a set of Cartesian sign conventions to be followed to trace image formed by spherical mirrors.
- Light travels with lesser velocity in optically denser medium.
- Optical path is the equivalent path travelled in vacuum in the same time light travels through an optically denser medium.
- The phenomenon of refraction is governed by laws of refraction (Snell's law).
- The apparent depth is always lesser than actual depth.
- Refraction takes place in atmosphere due to different layers of air with varying refractive indices.
- Total internal reflection takes place when light travels from denser to rarer medium with the angle of incidence greater than critical angle.
- There are several applications of total internal reflection.
- A glass slab produces lateral displacement or shift of ray entering into it.
- Thin lenses are formed by two spherical refracting surfaces.
- The image tracing in thin lenses is done with the Cartesian sign conventions and with the help of lens equation.
- Power and focal length are inverse to each other.
- There is effective focal length for lenses in contact and out of contact.
- Prism produces deviation on the incident ray.
- Angle of deviation depends on angle of prism, angle of incidence and refractive index of material of prism.
- The refractive index of prism depends on angle of prism and angle of minimum deviation.
- When white light travels through a medium, different colours travel with different speeds leading to dispersion of light.
- Dispersive power is the measure of ability of the medium to disperse white light.
- Rainbow is formed by dispersion of light by droplets of water.



- Light can be scattered by the particles present in atmosphere.
- The scattering of light by particles of size less than wavelength of light is called Rayleigh scattering which is inversely proportional to fourth power of wavelength.
- If the scattering is by suspended dust particles whose size is greater than wavelength of light, the scattering is independent of wavelength.
- There are four theories on light each explaining few aspects of light.
- Light has wave and particle nature.
- In wave optics we treat light propagating as a wavefront.
- Huygens' principle explains the propagation of light as wavefront.
- Laws of reflection and refraction are proved by Huygens' principle.
- In interference, two light waves are added to get varying intensities at different points.
- Coherent sources produce monochromatic light waves in phase or with constant phase difference.
- Coherent sources are obtained by intensity division, wavefront division and real and virtual images of light source.
- Young's double slit uses wavefront division to obtain coherent sources.
- Interference with polychromatic (white) light produces coloured interference fringes.
- Thin films appear coloured due to interference of white light.
- Bending of light around sharp edges is called diffraction.
- There are two types of diffractions called Fresnel and Fraunhofer diffractions
- Diffraction takes place at single slit which has a width comparable to the wavelength of light.
- Fresnel's distance is the distance up to which ray optics is obeyed.
- Diffraction can also happen in grating which has multiple slits of thickness comparable to wavelength of light used.
- Using diffraction grating and spectrometer wavelength of monochromatic light and also different colours of polychromatic light can be determined.
- Resolution is the quality of image which is decided by diffraction effect and Rayleigh criterion.
- Resolution is measured by the smallest distance which could be seen clearly without the blur due to diffraction.
- Polarisation is restricting electric or magnetic field vibrations to one plane.
- Polarisation is obtained by selective absorption, reflection, double refraction and scattering.
- Malus' law gives the intensity of emerging light when a polarised light enters two polaroids kept at an angle.
- Brewster's law relates angle of polarisation and refractive index of the medium.
- Optically active crystals can be classified as uniaxial and biaxial crystals.
- When light enters in to optically active crystals, double refraction takes place.



- In double refraction, ordinary ray obeys laws of refraction and extraordinary ray does not obey laws of refraction.
- Nicol prism separates ordinary and extraordinary rays by transparent cement called Canada balsam.
- Light scattered by molecules at perpendicular direction to the incident light is found to be plane polarised.
- Single convex lens can act as a simple microscope when object is within the focal length.
- Two focusing namely, near point focusing and normal focusing are possible.
- In near point focusing, the image is formed at 25 cm which is the distance of distinct vision for normal eye. Whereas, in normal focusing the image is formed at infinity.
- To find magnification in near point focusing we use lateral magnification and for normal focusing we use angular magnification.
- Resolution of microscope could be improved by using oil immersed eye piece.
- Compound microscope has improved magnification.
- Astronomical telescope has an eye piece of long focal length and eye piece of short focal length.
- Terrestrial telescopes have one addition lens for producing erect image.
- Reflecting telescopes have advantages as well as disadvantages.
- Eye has three problems (i) nearsightedness, (ii) farsightedness, (iii) astigmatism.

CONCEPT MAP

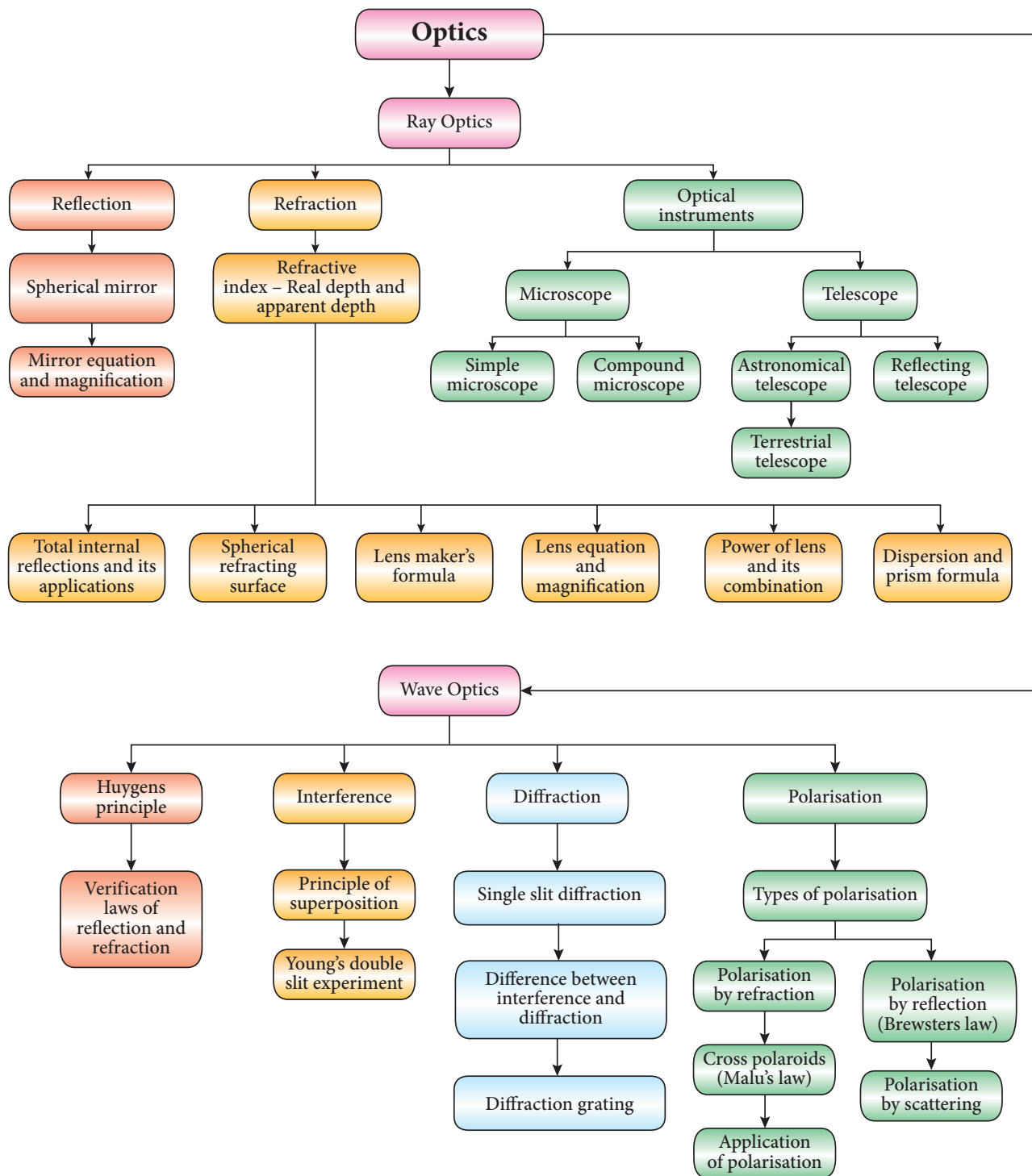



EVALUATION



Multiple choice questions

1. The speed of light in an isotropic medium depends on,

- (a) its intensity
- (b) its wavelength
- (c) the nature of propagation
- (d) the motion of the source w.r.t medium



2. A rod of length 10 cm lies along the principal axis of a concave mirror of focal length 10 cm in such a way that its end closer to the pole is 20 cm away from the mirror. The length of the image is, (AIPMT Main 2012)

- (a) 2.5 cm
- (b) 5 cm
- (c) 10 cm
- (d) 15 cm

3. An object is placed in front of a convex mirror of focal length of f and the maximum and minimum distance of an object from the mirror such that the image formed is real and magnified.

(IEE Main 2009)]

- (a) $2f$ and c
- (b) c and ∞
- (c) f and O
- (d) None of these

4. For light incident from air on a slab of refractive index 2, the maximum possible angle of refraction is,

- (a) 30°
- (b) 45°
- (c) 60°
- (d) 90°

5. If the velocity and wavelength of light in air is V_a and λ_a and that in water is V_w and λ_w , then the refractive index of water is,

- (a) $\frac{V_w}{V_a}$
- (b) $\frac{V_a}{V_w}$
- (c) $\frac{\lambda_w}{\lambda_a}$
- (d) $\frac{V_a \lambda_a}{V_w \lambda_w}$

6. Stars twinkle due to,

- (a) reflection
- (b) total internal reflection
- (c) refraction
- (d) polarisation

7. When a biconvex lens of glass having refractive index 1.47 is dipped in a liquid, it acts as a plane sheet of glass. This implies that the liquid must have refractive index,

- (a) less than one
- (b) less than that of glass
- (c) greater than that of glass
- (d) equal to that of glass

8. The radius of curvature of curved surface at a thin planoconvex lens is 10 cm and the refractive index is 1.5. If the plane surface is silvered, then the focal length will be,

- (a) 5 cm
- (b) 10 cm
- (c) 15 cm
- (d) 20 cm

9. An air bubble in glass slab of refractive index 1.5 (near normal incidence) is 5 cm deep when viewed from one surface and 3 cm deep when viewed from the opposite face. The thickness of the slab is,

- (a) 8 cm
- (b) 10 cm
- (c) 12 cm
- (d) 16 cm

10. A ray of light travelling in a transparent medium of refractive index n falls, on a surface separating the medium from air at an angle of incidence of 45° . The ray can undergo total internal reflection for the following n ,

- (a) $n = 1.25$
- (b) $n = 1.33$
- (c) $n = 1.4$
- (d) $n = 1.5$

11. A plane glass is placed over a various coloured letters (violet, green, yellow, red) The letter which appears to be raised more is,
 (a) red (b) yellow
 (c) green (d) violet
12. Two point white dots are 1 mm apart on a black paper. They are viewed by eye of pupil diameter 3 mm approximately. The maximum distance at which these dots can be resolved by the eye is, [take wavelength of light, $\lambda = 500 \text{ nm}$]
 (a) 1 m (b) 5 m
 (c) 3 m (d) 6m
13. In a Young's double-slit experiment, the slit separation is doubled. To maintain the same fringe spacing on the screen, the screen-to-slit distance D must be changed to,
 (a) $2D$ (b) $\frac{D}{2}$
 (c) $\sqrt{2}D$ (d) $\frac{D}{\sqrt{2}}$
14. Two coherent monochromatic light beams of intensities I and $4I$ are superposed. The maximum and minimum possible intensities in the resulting beam are [IIT-JEE 1988]
 (a) $5I$ and I (b) $5I$ and $3I$
 (c) $9I$ and I (d) $9I$ and $3I$
15. When light is incident on a soap film of thickness $5 \times 10^{-5} \text{ cm}$, the wavelength of light reflected maximum in the visible region is 5320 \AA . Refractive index of the film will be,
 (a) 1.22 (b) 1.33
 (c) 1.51 (d) 1.83.
16. First diffraction minimum due to a single slit of width $1.0 \times 10^{-5} \text{ cm}$ is at 30° . Then wavelength of light used is,
 (a) 400 \AA (b) 500 \AA
 (c) 600 \AA (d) 700 \AA
17. A ray of light strikes a glass plate at an angle 60° . If the reflected and refracted rays are perpendicular to each other, the refractive index of the glass is,
 (a) $\sqrt{3}$ (b) $\frac{3}{2}$
 (c) $\sqrt{\frac{3}{2}}$ (d) 2
18. One of the of Young's double slits is covered with a glass plate as shown in figure. The position of central maximum will,
 (a) get shifted downwards
 (b) get shifted upwards
 (c) will remain the same
 (d) data insufficient to conclude

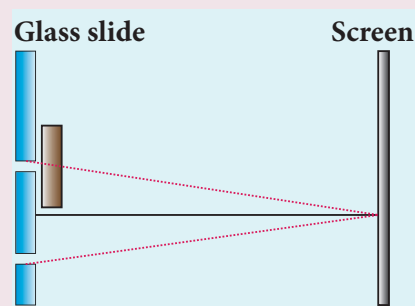

19. Light transmitted by Nicol prism is,
 (a) partially polarised
 (b) unpolarised
 (c) plane polarised
 (d) elliptically polarised
20. The transverse nature of light is shown in,
 (a) interference
 (b) diffraction
 (c) scattering
 (d) polarisation

Answers

- 1) b 2) b 3) d 4) a 5) b
6) c 7) d 8) b 9) c 10) d
11) d 12) b 13) a 14) c 15) b
16) b 17) a 18) b 19) c 20) d

Short Answer Questions

1. State the laws of reflection.
2. What is angle of deviation due to reflection?
3. Give the characteristics of image formed by a plane mirror.
4. Derive the relation between f and R for a spherical mirror.
5. What are the Cartesian sign conventions for a spherical mirror?
6. What is optical path? Obtain the equation for optical path of a medium of thickness d and refractive index n .
7. State the laws of refraction.
8. What is angle of deviation due to refraction?
9. What is principle of reversibility?
10. What is relative refractive index?
11. Obtain the equation for apparent depth.
12. Why do stars twinkle?
13. What is critical angle and total internal reflection?
14. Obtain the equation for critical angle.
15. Explain the reason for glittering of diamond.
16. What are mirage and looming?
17. Write a short notes on the prisms making use of total internal reflection.
18. What is Snell's window?
19. Write a note on optical fibre.
20. Explain the working of an endoscope.
21. What are primary focus and secondary focus of convex lens?
22. What are the sign conventions followed for lenses?
23. Arrive at lens equation from lens maker's formula.
24. Obtain the equation for lateral magnification for thin lens.
25. What is power of a lens?
26. Derive the equation for effective focal length for lenses in contact.
27. What is angle of minimum deviation?
28. What is dispersion?
29. How are rainbows formed?
30. What is Rayleigh's scattering?
31. Why does sky appear blue?
32. What is the reason for reddish appearance of sky during sunset and sunrise?
33. Why do clouds appear white?
34. What are the salient features of corpuscular theory of light?
35. What is wave theory of light?
36. What is electromagnetic wave theory of light?
37. Write a short note on quantum theory of light.
38. What is a wavefront?
39. What is Huygens' principle?
40. What is interference of light?
41. What is phase of a wave?
42. Obtain the relation between phase difference and path difference.
43. What are coherent sources?
44. What is intensity division?

45. How does wavefront division provide coherent sources?
46. How do source and images behave as coherent sources?
47. What is bandwidth of interference pattern?
48. What is diffraction?
49. Differentiate between Fresnel and Fraunhofer diffraction.
50. Discuss the special cases on first minimum in Fraunhofer diffraction.
51. What is Fresnel's distance? Obtain the equation for Fresnel's distance.
52. Mention the differences between interference and diffraction.
53. What is a diffraction grating?
54. What are resolution and resolving power?
55. What is Rayleigh's criterion?
56. What is polarisation?
57. Differentiate between polarised and unpolarised light
58. Discuss polarisation by selective absorption.
59. What are polariser and analyser?
60. What are plane polarised, unpolarised and partially polarised light?
61. State and obtain Malus' law.
62. List the uses of polaroids.
63. State Brewster's law.
64. What is angle of polarisation and obtain the equation for angle of polarisation.
65. Discuss about pile of plates.
66. What is double refraction?
67. Mention the types of optically active crystals with example.
68. Discuss about Nicol prism.
69. How is polarisation of light obtained by scattering of light?
70. Discuss about simple microscope and obtain the equations for magnification for near point focusing and normal focusing.
71. What are near point and normal focusing?
72. Why is oil immersed objective preferred in a microscope?
73. What are the advantages and disadvantages of using a reflecting telescope?
74. What is the use of an erecting lens in a terrestrial telescope?
75. What is the use of collimator?
76. What are the uses of spectrometer?
77. What is myopia? What is its remedy?
78. What is hypermetropia? What is its remedy?
79. What is presbyopia?
80. What is astigmatism?

Long Answer Questions

1. Derive the mirror equation and the equation for lateral magnification.
2. Describe the Fizeau's method to determine speed of light.
3. Obtain the equation for radius of illumination (or) Snell's window.
4. Derive the equation for acceptance angle and numerical aperture, of optical fiber.
5. Obtain the equation for lateral displacement of light passing through a glass slab.
6. Derive the equation for refraction at single spherical surface.

7. Obtain lens maker's formula and mention its significance.
8. Derive the equation for thin lens and obtain its magnification.
9. Derive the equation for effective focal length for lenses in out of contact.
10. Derive the equation for angle of deviation produced by a prism and thus obtain the equation for refractive index of material of the prism.
11. What is dispersion? Obtain the equation for dispersive power of a medium.
12. Prove laws of reflection using Huygens' principle.
13. Prove laws of refraction using Huygens' principle.
14. Obtain the equation for resultant intensity due to interference of light.
15. Explain the Young's double slit experimental setup and obtain the equation for path difference.
16. Obtain the equation for bandwidth in Young's double slit experiment.
17. Obtain the equations for constructive and destructive interference for transmitted and reflected waves in thin films.
18. Discuss diffraction at single slit and obtain the condition for n^{th} minimum.
19. Discuss the diffraction at a grating and obtain the condition for the m^{th} maximum.
20. Discuss the experiment to determine the wavelength of monochromatic light using diffraction grating.
21. Discuss the experiment to determine the wavelength of different colours using diffraction grating.
22. Obtain the equation for resolving power of optical instrument.
23. Discuss about simple microscope and obtain the equations for magnification for near point focusing and normal focusing.
24. Explain about compound microscope and obtain the equation for magnification.
25. Obtain the equation for resolving power of microscope.
26. Discuss about astronomical telescope.
27. Mention different parts of spectrometer and explain the preliminary adjustments.
28. Explain the experimental determination of material of the prism using spectrometer.

Conceptual Questions

1. Why are dish antennas curved?
2. What type of lens is formed by a bubble inside water?
3. It is possible for two lenses to produce zero power?
4. Why does sky look blue and clouds look white?
5. Why is yellow light preferred to during fog?
6. Two independent monochromatic sources cannot act as coherent sources, why?
7. Does diffraction take place at the Young's double slit?
8. Is there any difference between coloured light obtained from prism and colours of soap bubble?

9. A small disc is placed in the path of the light from distance source. Will the center of the shadow be bright or dark?
10. When a wave undergoes reflection at a denser medium, what happens to its phase?

Numerical Problems

1. An object is placed at a certain distance from a convex lens of focal length 20 cm. Find the distance of the object if the image obtained is magnified 4 times.

[Ans: -15 cm.]

2. A compound microscope has a magnification of 30. The focal length of eye piece is 5 cm. Assuming the final image to be at least distance of distinct vision, find the magnification produced by the objective.

[Ans: 5]

3. An object is placed in front of a concave mirror of focal length 20 cm. The image formed is three times the size of the object. Calculate two possible distances of the object from the mirror.

[Ans: -40/3 cm and -80/3 cm]

4. A small bulb is placed at the bottom of a tank containing water to a depth of 80 cm. What is the area of the surface of water through which light from the bulb can emerge out? Refractive index of water is 1.33. (Consider the bulb to be a point source.)

[Ans: 2.6 m²]

5. A thin converging glass lens made of glass with refractive index 1.5 has a power of + 5.0 D. When this lens is immersed in a liquid of refractive

index n , it acts as a divergent lens of focal length 100 cm. What must be the value of n ?

[Ans: 5/3]

6. If the distance D between an object and screen is greater than 4 times the focal length of a convex lens, then there are two positions of the lens for which images are formed on the screen. This method is called conjugate foci method. If d is the distance between the two positions of the lens, obtain the equation for focal length of the convex lens.

$$[\text{Ans: } \left(f = \frac{D^2 - d^2}{4D} \right)]$$

7. A beam of light of wavelength 600 nm from a distant source falls on a single slit 1 mm wide and the resulting diffraction pattern is observed on a screen 2 m away. What is the distance between the first dark fringe on either side of the central bright fringe?

[Ans: 2.4 mm]

8. In Young's double slit experiment, the slits are 2 mm apart and are illuminated with a mixture of two wavelength $\lambda_0 = 750$ nm and $\lambda = 900$ nm. What is the minimum distance from the common central bright fringe on a screen 2 m from the slits where a bright fringe from one interference pattern coincides with a bright fringe from the other?

[Ans: 4.5 mm]

9. In Young's double slit experiment, 62 fringes are seen in visible region for sodium light of wavelength 5893 Å. If violet light of wavelength 4359 Å is used in place of sodium light, then

what is the number of fringes seen?

[Ans: 84]

10. A compound microscope has a magnifying power of 100 when the image is formed at infinity. The objective has a focal length of 0.5 cm

and the tube length is 6.5 cm. What is the focal length of the eyepiece.

[Ans: 2 cm]

BOOKS FOR REFERENCE

1. Frances A. Jenkins and Harvey E. White, Fundamentals of Optics, 4th Edition, McGraw Hill Book Company, (2011).
2. David Halliday, Robert Resnick and Jearl Walker, Fundamentals of Physics, 6th Edition, John Wiley & Sons Inc., (2004).
3. H.C. Verma, Concepts of Physics [Part-1], 1st Edition, Bharathi Bhawan Publishers & Distributers Pvt. Ltd., (2008).
4. Roger A. Freedman, Hugh D. Young, Sears and Zemansky's University Physics, 12th Edition, Pearson, (2011).



ICT CORNER

Optics

In this activity you will be able to explore the behaviour of a Young's double slit experiment by adjusting the slit separation, the distance to the screen, and the wavelength of the light.

Topic: Young's double slit experiment.

STEPS:

- Open the browser and type
- 'tutor-homework.com/Physics_Help/double_slit_experiment.html' in the address bar.
- Change the slit separation (distance between two sources) and observe how the pattern of bright and dark fringes changes.
- What happens to the fringe width if distance between the source and screen decreases?
- Observe how does the fringe width in interference pattern vary with the wavelength of incident light?

Observe the pattern of bright and dark fringes by clicking the Run button.

Step1

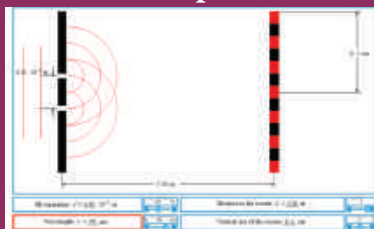

Step2

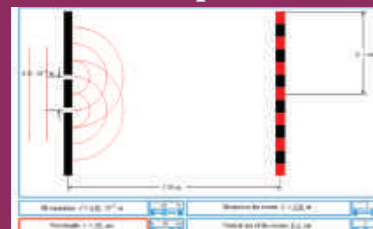

Step3

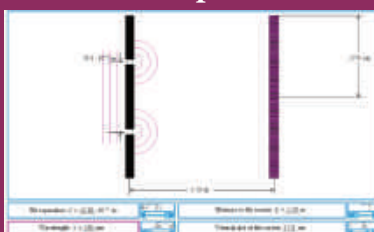

Step4



Note:

Use flash enabled browser or install flash player in your system.

URL:

http://tutor-homework.com/Physics_Help/double_slit_experiment.html

* Pictures are indicative only.

* If browser requires, allow **Flash Player** or **Java Script** to load the page.



B263_12_PHYSICS_EM

UNIT 7

DUAL NATURE OF RADIATION AND MATTER

"If quantum mechanics has not profoundly shocked you, you have not understood it yet"

– Neils Bohr

In this unit, the students are exposed to

- the phenomenon of electron emission and its types
- the observations of Hertz, Hallwachs and Lenard
- photoelectric effect and its laws
- the concept of quantization of energy
- photo cell and its applications
- particle nature of radiation
- the wave nature of matter
- de Broglie equation and de Broglie wavelength of electron
- the construction and working of electron microscope
- Davisson and Germer experiment
- X-rays and its production
- X-rays spectra and its types



7.1

INTRODUCTION

We are familiar with the concepts of particle and wave in our everyday experience. Marble balls, grains of sand, atoms, electrons and so on are some examples of particles while the examples of waves are sea waves, ripples in a pond, sound waves and light waves.

Particle is a material object which is considered as a tiny concentration of matter (localized in space and time) whereas wave is a broad distribution of energy (not localized in space and time). They, both particles and waves, have the ability to carry energy and momentum from one place to another.

Classical physics which describes the motion of the macroscopic objects treats particles and waves as separate components of physical reality. The mechanics of particles and the optics of waves are traditionally independent subjects, each with its own experiments and principles.

Electromagnetic radiations are regarded as waves because they exhibit wave phenomena such as interference, diffraction and polarization under some suitable circumstances. Similarly, under other circumstances like black body radiation and photo electric effect, electromagnetic radiations behave as though they consist of stream of particles.

When electrons, protons and other particles are discovered, they are considered as particles because they possess mass and

charge. However, later experiments showed that under certain circumstance, they exhibit wave-like properties.

In this unit, the particle nature of waves (radiation) and then the wave nature of particles (matter) – that is, wave-particle duality of radiation and matter are discussed with the relevant experimental observations which support this dual nature.

7.1.1 Electron emission

In metals, the electrons in the outer most shells are loosely bound to the nucleus. Even at room temperature, there are a large number of free electrons which are moving inside the metal in a random manner. Though they move freely inside the metal, they cannot leave the surface of the metal. The reason is that when free electrons reach the surface of the metal, they are attracted by the positive nuclei of the metal. It is this attractive pull which will not allow free electrons to leave the metallic surface at room temperature.

In order to leave the metallic surface, the free electrons must cross a potential barrier created by the positive nuclei of the metal. **The potential barrier which prevents free electrons from leaving the metallic surface is called surface barrier.**

Free electrons possess some kinetic energy and this energy is different for different electrons. The kinetic energy of the free electrons is not sufficient to overcome the surface barrier. Whenever an additional energy is given to the free electrons, they will have sufficient energy to cross the surface barrier. And they escape from the metallic surface. **The liberation of electrons from any surface of a substance is called electron emission.**

The minimum energy needed for an electron to escape from the metal surface is called work function of that metal. The work function of the metal is denoted by ϕ_0 and is measured in electron volt (eV).



Note

The SI unit of energy is joule. But electron volt is a commonly used unit of energy in atomic and nuclear physics.

One electron volt is defined as the kinetic energy gained by an electron when accelerated by a potential difference of 1 V.

$$\begin{aligned} 1 \text{ eV} &= \text{KE gained by the electron} \\ &= \text{Work done by the electric field} \\ &= qV \\ &= 1.602 \times 10^{-19} \text{ C} \times 1 \text{ V} \\ &= 1.602 \times 10^{-19} \text{ J} \end{aligned}$$

Suppose the maximum kinetic energy of the free electron inside the metal is 0.5 eV and the energy needed to overcome the surface barrier of a metal is 3 eV , then the minimum energy needed for electron emission from the metallic surface is $3 - 0.5 = 2.5 \text{ eV}$. Here 2.5 eV is the work function of the metal.

The work function is different for different metals and is a typical property of metals and the nature of their surface. Table 7.1 gives the approximate value of work function for various metals. The material with smaller work function is more effective in electron emission because extra energy required to release the free electrons from the metal surface is smaller.

Table 7.1 Work function of some materials

Metal	Symbol	Work function (eV)	Metal	Symbol	Work function (eV)
Cesium	Cs	2.14	Aluminium	Al	4.28
Potassium	K	2.30	Mercury	Hg	4.49
Sodium	Na	2.75	Copper	Cu	4.65
Calcium	Ca	3.20	Silver	Ag	4.70
Molybdenum	Mo	4.17	Nickel	Ni	5.15
Lead	Pb	4.25	Platinum	Pt	5.65

So the metal selected for electron emission should have low work function. The electron emission is categorized into different types depending upon the form of energy being utilized. There are mainly four types of electron emission which are given below.

i) Thermionic emission

When a metal is heated to a high temperature, the free electrons on the surface of the metal get sufficient energy in the form of thermal energy so that they are emitted from the metallic surface (Figure 7.1). This type of emission is known as **thermionic emission**.

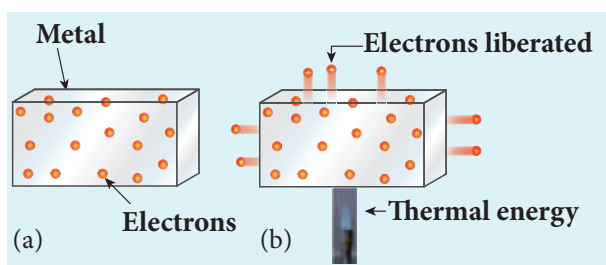

Figure 7.1 Electrons in the (a) metal (b) heated metal

The intensity of the thermionic emission (the number of electrons emitted) depends on the metal used and its temperature. **Examples:** cathode ray tubes, electron microscopes, X-ray tubes etc (Figure 7.2).

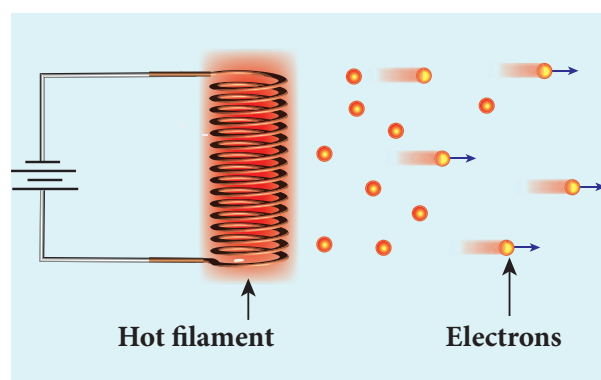

Figure 7.2 Thermionic emission from hot filament of cathode ray tube or X-ray tube

ii) Field emission

Electric field emission occurs when a very strong electric field is applied across the metal. This strong field pulls the free electrons and helps them to overcome the surface barrier of the metal (Figure 7.3). **Examples:** Field emission scanning electron microscopes, Field-emission display etc.

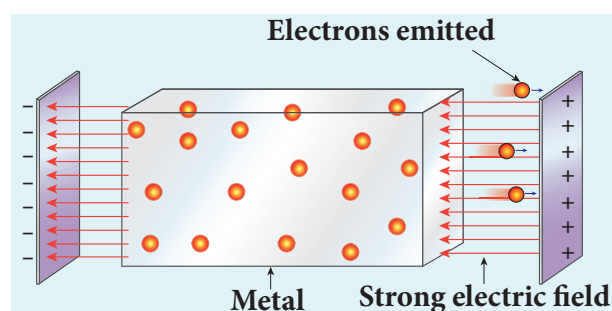

Figure 7.3 Field emission

iii) Photo electric emission

When an electromagnetic radiation of suitable frequency is incident on the surface of the metal, the energy is transferred from the radiation to the free electrons. Hence, the free electrons get sufficient energy to cross the surface barrier and the photo electric emission takes place (Figure 7.4). The number of electrons emitted depends on the intensity of the incident radiation. **Examples:** Photo diodes, photo electric cells etc.

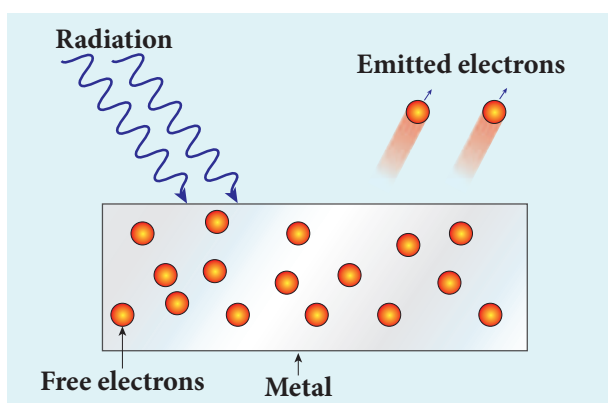

Figure 7.4 Photo electric emission

iv) Secondary emission

When a beam of fast moving electrons strikes the surface of the metal, the kinetic energy of the striking electrons is transferred to the free electrons on the metal surface. Thus the free electrons get sufficient kinetic energy so that the secondary emission of electron occurs (Figure 7.5). **Examples:** Image intensifiers, photo multiplier tubes etc.

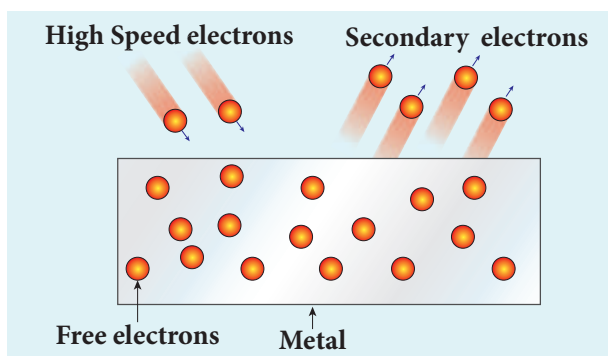

Figure 7.5 Secondary emission of electrons

7.2

PHOTO ELECTRIC EFFECT

7.2.1 Hertz, Hallwachs and Lenard's observation

Hertz observation

Maxwell's theory of electromagnetism predicted the existence of electromagnetic waves and concluded that light itself is just an electromagnetic wave. Then the experimentalists tried to generate and detect electromagnetic waves through various experiments.

In 1887, Heinrich Hertz first became successful in generating and detecting electromagnetic wave with his high voltage induction coil to cause a spark discharge between two metallic spheres (we have learnt this in Unit 5 of XII standard physics). When a spark is formed, the charges will oscillate back and forth rapidly and the electromagnetic waves are produced.

The electromagnetic waves thus produced were detected by a detector that has a copper wire bent in the shape of a circle. Although the detection of waves is successful, there is a problem in observing the tiny spark produced in the detector.

In order to improve the visibility of the spark, Hertz made many attempts and finally noticed an important thing that small detector spark became more vigorous when it was exposed to ultraviolet light.

The reason for this behaviour of the spark was not known at that time. Later it was found that it is due to the photoelectric emission. Whenever ultraviolet light is incident on the metallic sphere, the electrons on the outer surface are emitted which caused the spark to be more vigorous.



It is interesting to note that the experiment of Hertz confirmed that light is an electromagnetic wave. But the same experiment also produced the first evidence for particle nature of light.

Hallwachs' observation

In 1888, Wilhelm Hallwachs, a German physicist, confirmed that the strange behaviour of the spark is due to the action of ultraviolet light with his simple experiment.

A clean circular plate of zinc is mounted on an insulating stand and is attached to a gold leaf electroscope by a wire. When the uncharged zinc plate is irradiated by ultraviolet light from an arc lamp, it becomes positively charged and the leaves will open as shown in Figure 7.6(a).

Further, if the negatively charged zinc plate is exposed to ultraviolet light, the leaves will close as the charges leaked away quickly (Figure 7.6(b)). If the plate is positively charged, it becomes more positive upon UV rays irradiation and the leaves will open further (Figure 7.6(c)). From these observations, it was concluded that negatively charged electrons were emitted from the zinc plate under the action of ultraviolet light.

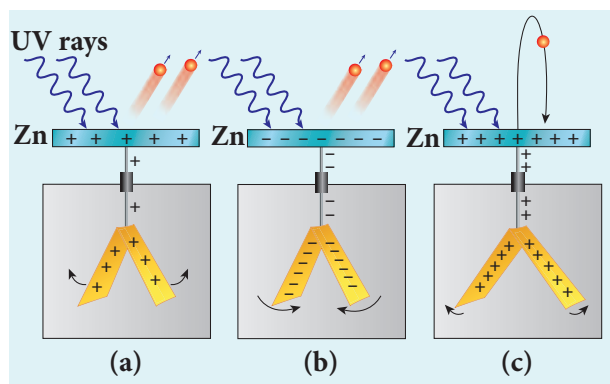

Figure 7.6 Irradiation of ultraviolet light on (a) uncharged zinc plate (b) negatively charged plate (c) positively charged plate

Lenard's observation

In 1902, Lenard studied this electron emission phenomenon in detail. His simple experimental setup is as shown in Figure 7.7. The apparatus consists of two metallic plates A and C placed in an evacuated quartz bulb. The galvanometer G and battery B are connected in the circuit.

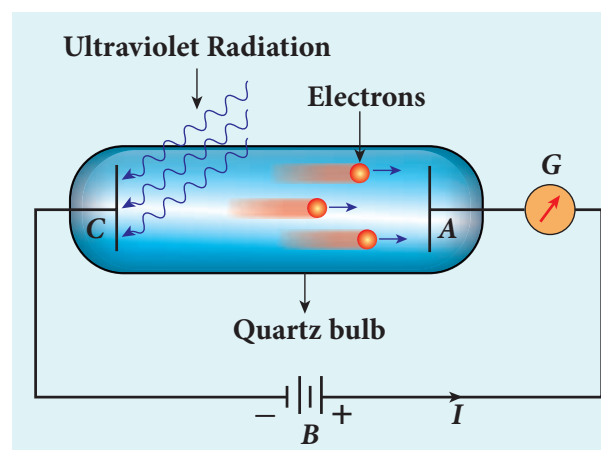

Figure 7.7 Experimental setup of Lenard

When ultraviolet light is incident on the negative plate C, an electric current flows in the circuit that is indicated by the deflection in the galvanometer. On other hand, if the positive plate is irradiated by the ultraviolet light, no current is observed in the circuit.

From these observations, it is concluded that when ultraviolet light falls on the negative plate, electrons are ejected from it which are attracted by the positive plate A. On reaching the positive plate through the evacuated bulb, the circuit is completed and the current flows in it. Thus, the ultraviolet light falling on the negative plate causes the electron emission from the surface of the plate.

Photoelectric effect

The ejection of electrons from a metal plate when illuminated by light or any other electromagnetic radiation

of suitable wavelength (or frequency) is called **photoelectric effect**. Although these electrons are not different from all other electrons, it is customary to call them as **photoelectrons** and the corresponding current as **photoelectric current or photo current**.

Metals like cadmium, zinc, magnesium etc show photoelectric emission for ultraviolet light while some alkali metals lithium, sodium, caesium respond well even to larger wavelength radiation like visible light. The materials which eject photoelectrons upon irradiation of electromagnetic wave of suitable wavelength are called **photosensitive materials**.

7.2.2 Effect of intensity of incident light on photoelectric current

Experimental setup

The apparatus shown in Figure 7.8 is employed to study the phenomenon of photoelectric effect in detail. S is a source of electromagnetic waves of known and variable frequency ν and intensity I . C is

the cathode (negative electrode) made up of photosensitive material and is used to emit electrons. The anode (positive electrode) A collects the electrons emitted from C . These electrodes are taken in an evacuated glass envelope with a quartz window that permits the passage of ultraviolet and visible light.

The necessary potential difference between C and A is provided by high tension battery B which is connected across a potential divider arrangement PQ through a key K . C is connected to the centre terminal while A to the sliding contact J of the potential divider. The plate A can be maintained at a desired positive or negative potential with respect to C . To measure both positive and negative potential of A with respect to C , the voltmeter is designed to have its zero marking at the centre and is connected between A and C . The current is measured by a micro ammeter μA in series.

If there is no light falling on the cathode C , no photoelectrons are emitted and the microammeter reads zero. When ultraviolet or visible light is allowed to fall on C , the photoelectrons are liberated and are attracted towards anode. As a result, the

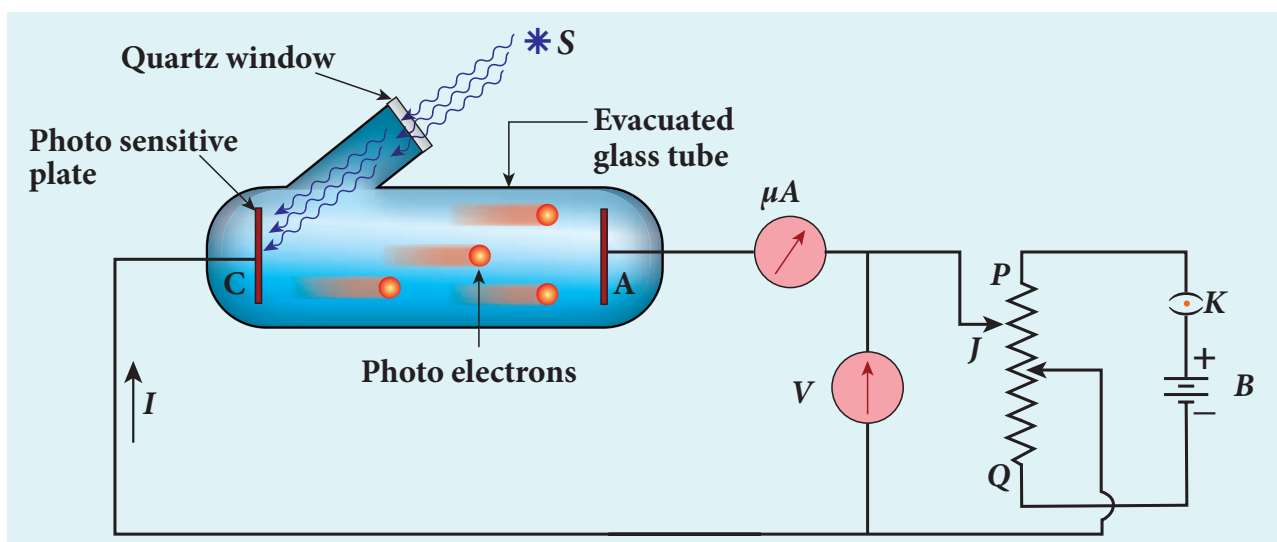

Figure 7.8 Experimental setup for the study of photoelectric effect

photoelectric current is set up in the circuit which is measured using micro ammeter.

The variation of photocurrent with respect to (i) intensity of incident light (ii) the potential difference between the electrodes (iii) the nature of the material and (iv) frequency of incident light can be studied with the help of this apparatus.

Effect of intensity of incident light on photoelectric current

To study the effect of intensity of incident light on photoelectric current, the frequency of the incident light and the accelerating potential V of the anode are kept constant. Here the potential of A is kept positive with respect to that of C so that the electrons emitted from C are attracted towards A . Now, the intensity of the incident light is varied and the corresponding photoelectric current is measured.

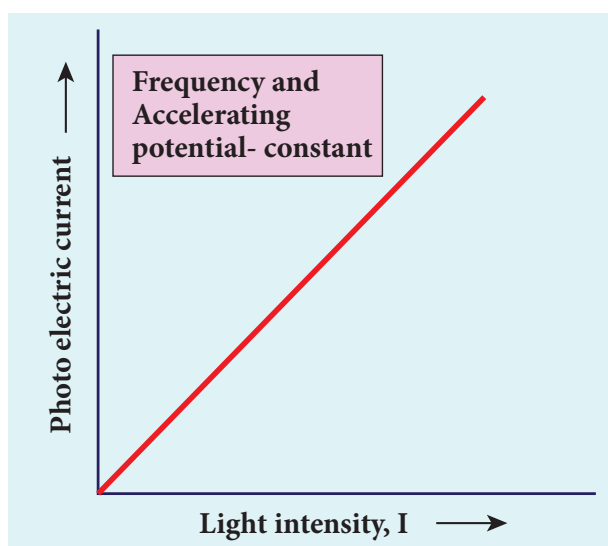

Figure 7.9 Variation of photocurrent with intensity

A graph is drawn between light intensity along x-axis and the photocurrent along y-axis. From the graph in Figure 7.9, it is evident that *photocurrent – the number of electrons emitted per second – is directly proportional to the intensity of the incident light.*



Here, intensity of light means brightness. A bright light has more intensity than a dim light.

7.2.3 Effect of potential difference on photoelectric current

To study the effect of potential difference V between the electrodes on photoelectric current, the frequency and intensity of the incident light are kept constant. Initially the potential of A is kept positive with respect to C and the cathode is irradiated with the given light.

Now, the potential of A is increased and the corresponding photocurrent is noted. As the potential of A is increased, photocurrent is also increased. However a stage is reached where photocurrent reaches a saturation value (saturation current) at which all the photoelectrons from C are collected by A . This is represented by the flat portion of the graph between potential of A and photocurrent (Figure 7.10).

When a negative (retarding) potential is applied to A with respect to C , the current does not immediately drop to zero because the photoelectrons are emitted with some definite and different kinetic energies. The kinetic energy of some of the photoelectrons is such that they could overcome the retarding electric field and reach the electrode A .

When the negative (retarding) potential of A is gradually increased, the photocurrent starts to decrease because more and more photoelectrons are being repelled away from reaching the electrode A . The photocurrent becomes zero at a

particular negative potential V_0 , called stopping or cut-off potential.

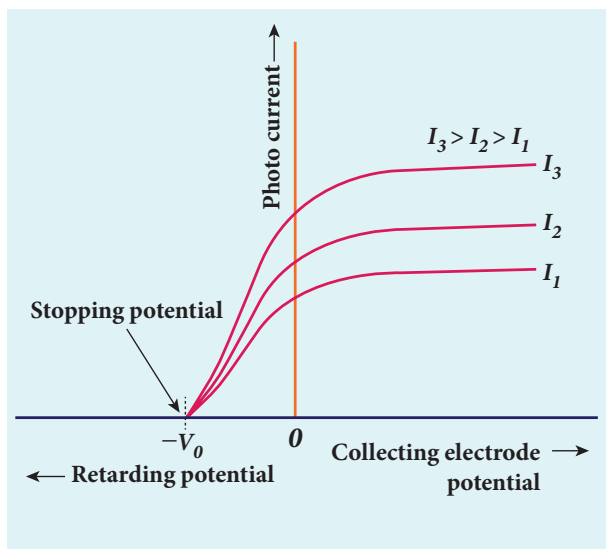

Figure 7.10 Variation of photocurrent with potential difference

Stopping potential is that the value of the negative (retarding) potential given to the collecting electrode A which is just sufficient to stop the most energetic photoelectrons emitted and make the photocurrent zero.

At the stopping potential, even the most energetic electron is brought to rest. Therefore, the initial kinetic energy of the fastest electron (K_{\max}) is equal to the work done by the stopping potential to stop it (eV_0).

$$K_{\max} = \frac{1}{2} m v_{\max}^2 = eV_0 \quad (7.1)$$

where v_{\max} is the maximum speed of the emitted photoelectron.

$$v_{\max} = \sqrt{\frac{2eV_0}{m}}$$

$$v_{\max} = \sqrt{\frac{2 \times 1.602 \times 10^{-19}}{9.1 \times 10^{-31}} \times V_0}$$

$$= 5.93 \times 10^5 \sqrt{V_0} \quad (7.2)$$

From equation (7.1),

$$K_{\max} = eV_0 \text{ (in joule) (or) } \quad (7.3)$$

$$K_{\max} = V_0 \text{ (in eV)}$$

From the Figure 7.10, when the intensity of the incident light alone is increased, the saturation current also increases but the value of V_0 remains constant.

Thus, for a given frequency of the incident light, the stopping potential is independent of intensity of the incident light. This also implies that *the maximum kinetic energy of the photoelectrons is independent of intensity of the incident light.*

7.2.4 Effect of frequency of incident light on stopping potential

To study the effect of frequency of incident light on stopping potential, the intensity of the incident light is kept constant. The variation of photocurrent with the collector electrode potential is studied for radiations of different frequencies and a graph drawn between them is shown in Figure 7.11. From the graph, it is clear that stopping potential vary over different frequencies of incident light.

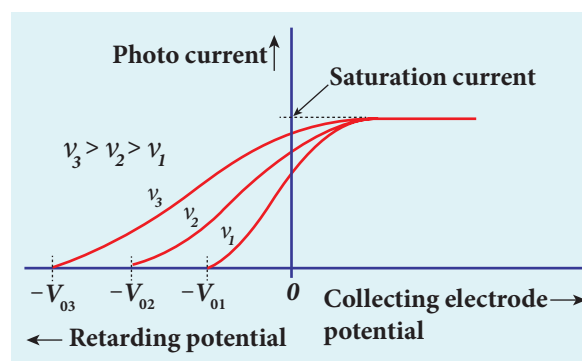

Figure 7.11 Variation of photocurrent with collector electrode potential for different frequencies of the incident radiation

Greater the frequency of the incident radiation, larger is the corresponding stopping potential. This implies that *as the frequency is increased, the photoelectrons are emitted with greater kinetic energies so that the retarding potential needed to stop the photoelectrons is also greater.*

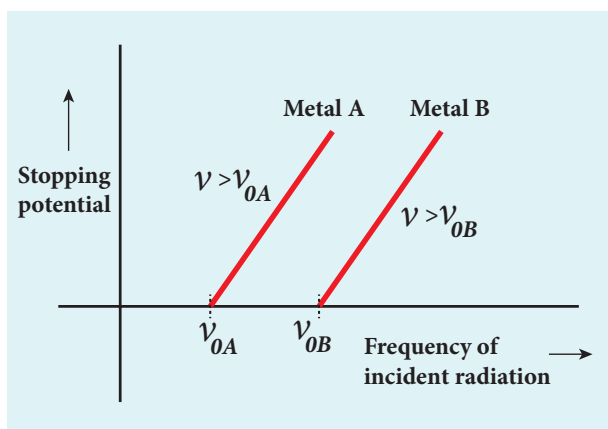

Figure 7.12 Variation of stopping potential with frequency of the incident radiation for two metals

Now a graph is drawn between frequency and the stopping potential for different metals (Figure 7.12). From this graph, it is found that stopping potential varies linearly with frequency. Below a certain frequency called threshold frequency, no electrons are emitted; hence stopping potential is zero for that reason. But as the frequency is increased above threshold value, the stopping potential varies linearly with the frequency of incident light.

7.2.5 Laws of photoelectric effect

The above detailed experimental investigations of photoelectric effect revealed the following results:

- i) For a given frequency of incident light, the number of photoelectrons emitted is directly proportional to the intensity

of the incident light. The saturation current is also directly proportional to the intensity of incident light.

- ii) Maximum kinetic energy of the photoelectrons is independent of intensity of the incident light.
- iii) Maximum kinetic energy of the photoelectrons from a given metal is directly proportional to the frequency of incident light.
- iv) For a given surface, the emission of photoelectrons takes place only if the frequency of incident light is greater than a certain minimum frequency called the threshold frequency.
- v) There is no time lag between incidence of light and ejection of photoelectrons.

Once photoelectric phenomenon has been thoroughly examined through various experiments, the attempts were made to explain it on the basis of wave theory of light.

7.2.6 Concept of quantization of energy

Failures of classical wave theory

From Maxwell's theory (Refer unit 5 of volume 1), we learnt that light is an electromagnetic wave consisting of coupled electric and magnetic oscillations that move with the speed of light and exhibit typical wave behaviour. Let us try to explain the experimental observations of photoelectric effect using wave picture of light.

- i) When light is incident on the target, there is a continuous supply of energy to the electrons. According to wave theory, light of greater intensity should impart greater kinetic energy to the liberated electrons (Here, Intensity of light is the energy delivered per unit area per unit time).

But this does not happen. The experiments show that maximum kinetic energy of the photoelectrons does not depend on the intensity of the incident light.

ii) According to wave theory, if a sufficiently intense beam of light is incident on the surface, electrons will be liberated from the surface of the target, however low the frequency of the radiation is.

From the experiments, we know that photoelectric emission is not possible below a certain minimum frequency. Therefore, the wave theory fails to explain the existence of threshold frequency.

iii) Since the energy of light is spread across the wavefront, the electrons which receive energy from it are large in number. Each electron needs considerable amount of time (a few hours) to get energy sufficient to overcome the work function and to get liberated from the surface.

But experiments show that photoelectric emission is almost instantaneous process (the time lag is less than 10^{-9} s after the surface is illuminated) which could not be explained by wave theory.

Thus, the experimental observations of photoelectric emission could not be explained on the basis of the wave theory of light.

EXAMPLE 7.1

For the photoelectric emission from cesium, show that wave theory predicts that

i) maximum kinetic energy of the photoelectrons (K_{max}) depends on the intensity I of the incident light

ii) K_{max} does not depend on the frequency of the incident light and

iii) the time interval between the incidence of light and the ejection of photoelectrons is very long.

(Given : The work function for cesium is 2.14 eV and the power absorbed per unit area is $1.60 \times 10^{-6} \text{ Wm}^{-2}$ which produces a measurable photocurrent in cesium.)

Solution

i) According to wave theory, the energy in a light wave is spread out uniformly and continuously over the wavefront. For the sake of simplicity, the following assumptions are made.

- Light is absorbed in the top atomic layer of the metal
- For a given element, each atom absorbs an equal amount of energy and this energy is proportional to its cross-sectional area A
- Each atom gives this energy to one of the electrons.

The energy absorbed by each electron in time t is given by

$$E = IAt$$

With this energy absorbed, the most energetic electron is released with K_{max} by overcoming the surface energy barrier or work function ϕ_0 and this is expressed as

$$K_{max} = IAt - \phi_0 \quad (1)$$

Thus, wave theory predicts that for a unit time, at low light intensities when $IA < \phi_0$, no electrons are emitted. At higher intensities, when $IA \geq \phi_0$, electrons are emitted. This implies that higher the light intensity, greater will be K_{max} .

Therefore, the predictions of wave theory contradict experimental observations at both very low and very high light intensities.

K_{max} is dependent only on the intensity under given conditions – that is, by suitably increasing the intensity, one can produce

photoelectric effect even if the frequency is less than the threshold frequency. So the concept of threshold frequency does not even exist in wave theory.

ii) According to wave theory, the intensity of a light wave is proportional to the square of the amplitude of the electric field (E_0^2). The amplitude of this electric field increases with increasing intensity and imparts an increasing acceleration and kinetic energy to an electron.

Now I is replaced with a quantity proportional to E_0^2 in equation (1). This means that K_{max} should not depend at all on the frequency of the classical light wave which again contradicts the experimental results.

iii) If an electron accumulates light energy just enough to overcome the work function, then it is ejected out of the atom with zero kinetic energy. Therefore, from equation (1),

$$0 = IAt - \phi_0$$

$$t = \frac{\phi_0}{IA} = \frac{\phi_0}{I(\pi r^2)}$$

By taking the atomic radius $r = 1.0 \times 10^{-10} \text{ m}$ and substituting the given values of I and ϕ_0 , we can estimate the time interval as

$$t = \frac{2.14 \times 1.6 \times 10^{-19}}{1.60 \times 10^{-6} \times 3.14 \times (1 \times 10^{-10})^2}$$

$$= 0.68 \times 10^7 \text{ s} \approx 79 \text{ days}$$

Thus, wave theory predicts that there is a large time gap between the incidence of light and the ejection of photoelectrons but the experiments show that photo emission is an instantaneous process.

Concept of quantization of energy

Max Planck proposed quantum concept in 1900 in order to explain the thermal

radiations emitted by a black body and the shape of its radiation curves.

According to Planck, matter is composed of a large number of oscillating particles (atoms) which vibrate with different frequencies. Each atomic oscillator - which vibrates with its characteristic frequency - emits or absorbs electromagnetic radiation of the same frequency. It also says that

i) If an oscillator vibrates with frequency ν , its energy can have only certain discrete values, given by the equation.

$$E_n = nh\nu \quad n=1,2,3,\dots \quad (7.4)$$

where h is a constant, called Planck's constant.

ii) The oscillators emit or absorb energy in small packets or quanta and the energy of each quantum is $E = h\nu$.

This implies that the energy of the oscillator is quantized - that is, energy is not continuous as believed in the wave picture. This is called **quantization of energy**.

7.2.7 Particle nature of light: Einstein's explanation

Einstein extended Planck's quantum concept to explain the photoelectric effect in 1905. According to Einstein, the energy in light is not spread out over wavefronts but is concentrated in small packets or energy quanta. Therefore, light (or any other electromagnetic waves) of frequency ν from any source can be considered as a stream of quanta and the energy of each light quantum is given by $E = h\nu$.

He also proposed that a quantum of light has linear momentum and the magnitude of that linear momentum is $p = \frac{h\nu}{c}$. The individual light quantum of definite energy and momentum can be associated with a

particle. The light quantum can behave as a particle and this is called photon. Therefore, photon is nothing but particle manifestation of light.

Characteristics of photons:

According to particle nature of light, photons are the basic constituents of any radiation and possess the following characteristic properties:

- i) The photons of light of frequency ν and wavelength λ will have energy, given by

$$E = h\nu = \frac{hc}{\lambda}.$$

- ii) The energy of a photon is determined by the frequency of the radiation and not by its intensity and the intensity has no relation with the energy of the individual photons in the beam.

- iii) The photons travel with the velocity of light and its momentum is given by

$$p = \frac{h}{\lambda} = \frac{h\nu}{c}$$

- iv) Since photons are electrically neutral, they are unaffected by electric and magnetic fields.
- v) When a photon interacts with matter (photon-electron collision), the total energy, total linear momentum and angular momentum are conserved. Since photon may be absorbed or a new photon may be produced in such interactions, the number of photons may not be conserved.



Note According to quantum concept, intensity of light of given wavelength is defined as the number of energy quanta or photons incident per unit area per unit time, with each photon having same energy. The unit is Wm^{-2} .

Einstein's explanation of photoelectric equation

When a photon of energy $h\nu$ is incident on a metal surface, it is completely absorbed by a single electron and the electron is ejected. In this process, a part of the photon energy is used for the ejection of the electrons from the metal surface (photoelectric work function ϕ_0) and the remaining energy as the kinetic energy of the ejected electron. From the law of conservation of energy,

$$h\nu = \phi_0 + \frac{1}{2}mv^2 \quad (7.6)$$

where m is the mass of the electron and v its velocity. This is shown in Figure 7.13(a).

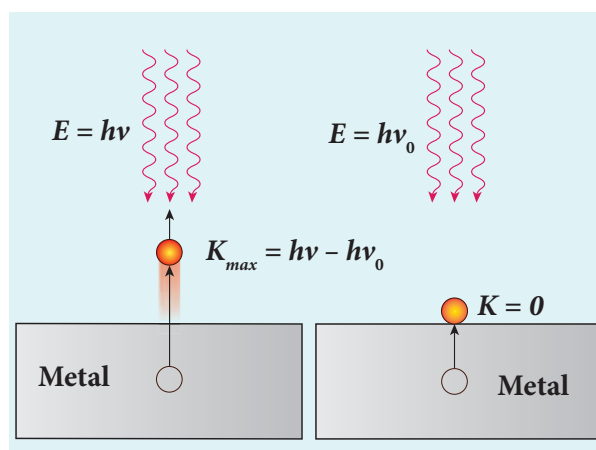

Figure 7.13 Emission of photoelectrons

If we reduce the frequency of the incident light, the speed or kinetic energy of photo electrons is also reduced. At some frequency ν_0 of incident radiation, the photo electrons are ejected with almost zero kinetic energy (Figure 7.13(b)). Then the equation (7.6) becomes

$$h\nu_0 = \phi_0$$

where ν_0 is the threshold frequency. By

rewriting the equation (7.6), we get

$$h\nu = h\nu_0 + \frac{1}{2}m\nu_{\max}^2 \quad (7.7)$$

The equation (7.7) is known as **Einstein's photoelectric equation**.

If the electron does not lose energy by internal collisions, then it is emitted with maximum kinetic energy K_{\max} . Then

$$K_{\max} = \frac{1}{2}m\nu_{\max}^2$$

where ν_{\max} is the maximum velocity of the electron ejected. The equation (7.6) is rearranged as follows:

$$K_{\max} = h\nu - \phi_0 \quad (7.8)$$

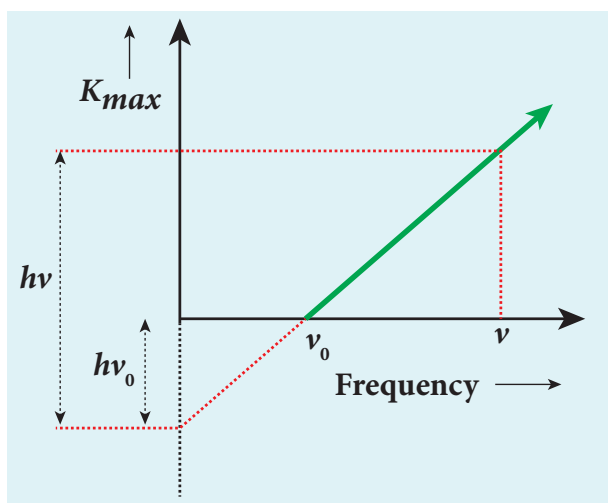

Figure 7.14 K_{\max} vs ν graph

A graph between maximum kinetic energy K_{\max} of the photoelectron and frequency ν of the incident light is a straight line as shown in Figure 7.14. The slope of the line is h and its y-intercept is $-\phi_0$.

Einstein's equation was experimentally verified by R.A. Millikan. He drew K_{\max} versus ν graph for many metals (cesium, potassium, sodium and lithium) as shown in Figure 7.15 and found that the slope is independent of the metals.

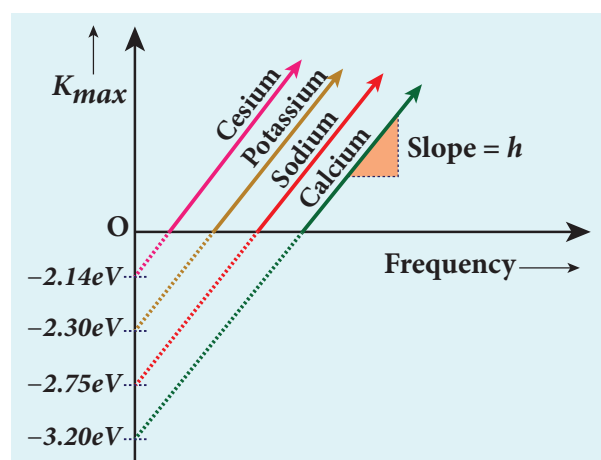

Figure 7.15 K_{\max} vs ν graph for different metals

Millikan also calculated the value of Planck's constant ($h=6.626 \times 10^{-34}$ Js) and work function of many metals (Cs, K, Na, Ca); these values are in agreement with the theoretical prediction.

Explanation for the photoelectric effect:

The experimentally observed facts of photoelectric effect can be explained with the help of Einstein's photoelectric equation.

i) As each incident photon liberates one electron, then the increase of intensity of the light (the number of photons per unit area per unit time) increases the number of electrons emitted thereby increasing the photocurrent. The same has been experimentally observed.

ii) From $K_{\max} = h\nu - \phi_0$, it is evident that K_{\max} is proportional to the frequency of the light and is independent of intensity of the light.

iii) As given in equation (7.7), there must be minimum energy (equal to the work function of the metal) for incident photons to liberate electrons from the metal surface. Below which, emission of electrons is not possible. Correspondingly, there exists minimum frequency called threshold frequency below which there is no photoelectric emission.

iv) According to quantum concept, the transfer of photon energy to the electrons is instantaneous so that there is no time lag between incidence of photons and ejection of electrons.

Thus, the photoelectric effect is explained on the basis of quantum concept of light.

The nature of light: wave - particle duality

We have learnt that wave nature of light explains phenomena such as interference, diffraction and polarization. Certain phenomena like black body radiation, photoelectric effect can be explained by assigning particle nature to light. Therefore, both theories have enough experimental evidences.

In the past, many scientific theories have been either revised or discarded when they contradicted with new experimental results. Here, two different theories are needed to answer the question: what is nature of light?

It is therefore concluded that light possesses dual nature, that of both particle and wave. It behaves like a wave at some circumstances and it behaves like a particle at some other circumstances.

In other words, light behaves as a wave during its propagation and behaves as a particle during its interaction with matter. Both theories are necessary for complete description of physical phenomena. Hence, the wave nature and quantum nature complement each other.

7.2.8 Photo electric cells and their applications

Photo cell

Photo electric cell or photo cell is a device which converts light energy into electrical energy. It works on the principle of photo electric effect. When light is incident on the photosensitive materials, their electric properties will get affected, based on which photo cells are classified into three types. They are

- i) **Photo emissive cell:** Its working depends on the electron emission from a metal cathode due to irradiation of light or other radiations.
- ii) **Photo voltaic cell:** Here sensitive element made of semiconductor is used which generates voltage proportional to the intensity of light or other radiations.
- iii) **Photo conductive cell:** In this, the resistance of the semiconductor changes in accordance with the radiant energy incident on it.

In this section, we discuss about photo emissive cell and its applications.

Photo emissive cell

Construction:

It consists of an evacuated glass or quartz bulb in which two metallic electrodes – that is, a cathode and an anode are fixed as shown in Figure 7.16.



A reader may find it difficult to understand how light can be both a wave and a stream of particle. This is the case even for great scientist like Albert Einstein.

Einstein once wrote a letter to his friend Michel Besso in 1954 expressing his frustration:

“All these fifty years of conscious brooding have brought me no closer to answer the question, ‘What are light quanta?’ Of course today everyone thinks he knows the answer, but he is deluding himself”.

The cathode C is semi-cylindrical in shape and is coated with a photo sensitive material. The anode A is a thin rod or wire kept along the axis of the semi-cylindrical cathode. A potential difference is applied between the anode and the cathode through a galvanometer G .

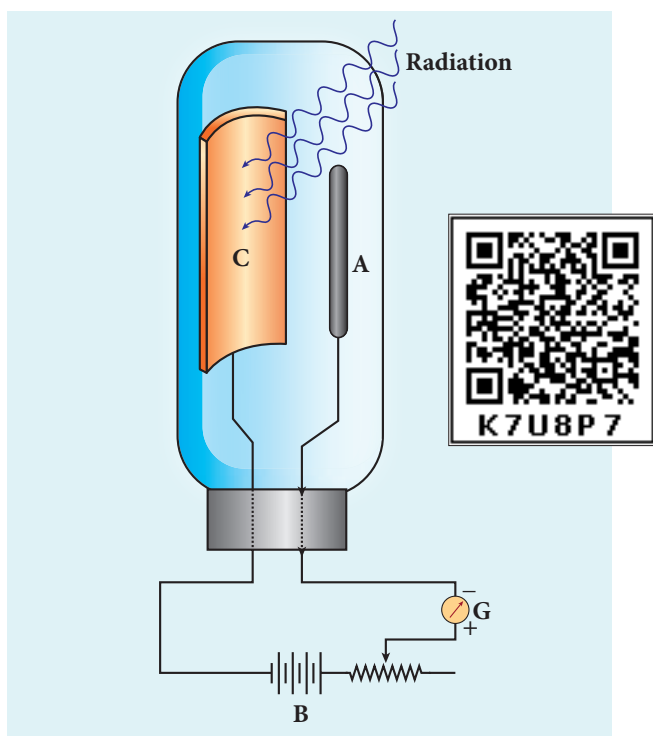

Figure 7.16 Construction of photo cell

Working:

When cathode is illuminated, electrons are emitted from it. These electrons are attracted by anode and hence a current is produced which is measured by the galvanometer. For a given cathode, the magnitude of the current depends on

- i) the intensity to incident radiation and
- ii) the potential difference between anode and cathode.

Applications of photo cells:

Photo cells have many applications, especially as switches and sensors. Automatic lights that turn on when it gets dark use photocells, as well as street lights

that switch on and off according to whether it is night or day.

Photo cells are used for reproduction of sound in motion pictures and are used as timers to measure the speeds of athletes during a race. Photo cells of exposure meters in photography are used to measure the intensity of the given light and to calculate the exact time of exposure.

EXAMPLE 7.2

A radiation of wavelength 300 nm is incident on a silver surface. Will photoelectrons be observed?

Solution:

Energy of the incident photon is

$$E = h\nu = \frac{hc}{\lambda} \text{ (in joules)}$$

$$E = \frac{hc}{\lambda e} \text{ (in eV)}$$

Substituting the known values, we get

$$E = \frac{6.626 \times 10^{-34} \times 3 \times 10^8}{300 \times 10^{-9} \times 1.6 \times 10^{-19}}$$

$$E = 4.14 \text{ eV}$$

From Table 7.1, the work function of silver = 4.7 eV . Since the energy of the incident photon is less than the work function of silver, photoelectrons are not observed in this case.

EXAMPLE 7.3

When light of wavelength 2200 \AA falls on Cu, photo electrons are emitted from it. Find (i) the threshold wavelength and (ii) the stopping potential. Given: the work function for Cu is $\phi_0 = 4.65 \text{ eV}$.

Solution

i) The threshold wavelength is given by

$$\begin{aligned}\lambda_0 &= \frac{hc}{\phi_0} = \frac{6.626 \times 10^{-34} \times 3 \times 10^8}{4.65 \times 1.6 \times 10^{-19}} \\ &= 2672 \text{ \AA}\end{aligned}$$

ii) Energy of the photon of wavelength 2200 \AA is

$$\begin{aligned}E &= \frac{hc}{\lambda} = \frac{6.626 \times 10^{-34} \times 3 \times 10^8}{2200 \times 10^{-10}} \\ &= 9.035 \times 10^{-19} \text{ J} = 5.65 \text{ eV}\end{aligned}$$

We know that kinetic energy of fastest photo electron is

$$\begin{aligned}K_{\max} &= h\nu - \phi_0 = 5.65 - 4.65 \\ &= 1 \text{ eV}\end{aligned}$$

From equation (7.3), $K_{\max} = eV_0$

$$V_0 = \frac{K_{\max}}{e} = \frac{1 \times 1.6 \times 10^{-19}}{1.6 \times 10^{-19}}$$

Therefore, stopping potential = 1 V

EXAMPLE 7.4

The work function of potassium is 2.30 eV . UV light of wavelength 3000 \AA and intensity 2 Wm^{-2} is incident on the potassium surface.

i) Determine the maximum kinetic energy of the photo electrons ii) If 40% of incident photons produce photo electrons, how many electrons are emitted per second if the area of the potassium surface is 2 cm^2 ?

Solution

i) The energy of the photon is

$$\begin{aligned}E &= \frac{hc}{\lambda} = \frac{6.626 \times 10^{-34} \times 3 \times 10^8}{3000 \times 10^{-10}} \\ E &= 6.626 \times 10^{-19} \text{ J} = 4.14 \text{ eV}\end{aligned}$$

Maximum KE of the photoelectrons is

$$K_{\max} = h\nu - \phi_0 = 4.14 - 2.30 = 1.84 \text{ eV}$$

ii) The number of photons reaching the surface per second is

$$\begin{aligned}n_p &= \frac{P}{E} \times A \\ &= \frac{2}{6.626 \times 10^{-19}} \times 2 \times 10^{-4} \\ &= 6.04 \times 10^{14} \text{ photons / sec}\end{aligned}$$

The rate of emission of photoelectrons is

$$\begin{aligned}&= (0.40)n_p = 0.4 \times 6.04 \times 10^{14} \\ &= 2.415 \times 10^{14} \text{ photoelectrons / sec}\end{aligned}$$

EXAMPLE 7.5

Light of wavelength 390 nm is directed at a metal electrode. To find the energy of electrons ejected, an opposing potential difference is established between it and another electrode. The current of photoelectrons from one to the other is stopped completely when the potential difference is 1.10 V . Determine i) the work function of the metal and ii) the maximum wavelength of light that can eject electrons from this metal.

Solution

i) The work function is given by

$$\begin{aligned}\phi_0 &= h\nu - K_{\max} = \frac{hc}{\lambda} - eV_0 \\ &\quad \text{since } K_{\max} = eV_0 \\ &= \left[\frac{6.626 \times 10^{-34} \times 3 \times 10^8}{390 \times 10^{-9}} \right] - [1.6 \times 10^{-19} \times 1.10] \\ &= 5.10 \times 10^{-19} - 1.76 \times 10^{-19} = 3.34 \times 10^{-19} \text{ J} \\ &= 2.09 \text{ eV}\end{aligned}$$

ii) The threshold wavelength is

$$\begin{aligned}\lambda_0 &= \frac{hc}{\phi_0} = \frac{6.626 \times 10^{-34} \times 3 \times 10^8}{3.33 \times 10^{-19}} \\ &= 5.969 \times 10^{-7} \text{ m} = 5963 \text{ \AA}\end{aligned}$$

7.3

MATTER WAVES

7.3.1 Introduction - Wave nature of particles

So far, we learnt that the characteristics of particles and waves are different. A wave is specified by its frequency, wavelength, wave velocity, amplitude and intensity. It spreads out and occupies a relatively large region of space. A particle specified by its mass, velocity, momentum and energy occupies a definite position in space and is very small in size.

Classical physics treated particles and waves as distinct entities. But quantum theory suggested dual character for radiations – that is, radiation behaves as a wave at times and as a particle at other times.

From this wave – particle duality of radiation, the concept of wave nature of matter arises which we will see in this section.

De Broglie wave:

The wave–particle duality of radiation was extended to matter by a French physicist Louis de Broglie (pronounced as de Broy) in 1924.

Greatly influenced by the symmetry in nature, de Broglie suggested that if radiation like light can act as particles at times, then matter particles like electrons should also act as waves at times.

According to de Broglie hypothesis, all matter particles like electrons, protons, neutrons in motion are associated with waves. These waves are called de Broglie waves or matter waves.

7.3.2 De Broglie wave length:

The momentum of photon of frequency ν is given by

$$p = \frac{h\nu}{c} = \frac{h}{\lambda} \quad \text{since } c = \nu\lambda$$

The wavelength of a photon in terms of its momentum is

$$\lambda = \frac{h}{p} \quad (7.9)$$

According to de Broglie, the above equation is completely a general one and this is applicable to material particles as well. Therefore, for a particle of mass m travelling with speed v , the wavelength is given by

$$\lambda = \frac{h}{mv} = \frac{h}{p} \quad (7.10)$$

This wavelength of the matter waves is known as **de Broglie wavelength**. This equation relates the wave character (the wave length λ) and the particle character (the momentum p) through Planck's constant.

7.3.3 De Broglie wave length of electrons:

An electron of mass m is accelerated through a potential difference of V volt. The kinetic energy acquired by the electron is given by

$$\frac{1}{2}mv^2 = eV$$

Therefore, the speed v of the electron is

$$v = \sqrt{\frac{2eV}{m}} \quad (7.11)$$

Hence, the de Broglie wavelength of the electron is

$$\lambda = \frac{h}{mv} = \frac{h}{\sqrt{2emV}} \quad (7.12)$$

Substituting the known values in the above equation, we get

$$\begin{aligned} \lambda &= \frac{6.626 \times 10^{-34}}{\sqrt{2V \times 1.6 \times 10^{-19} \times 9.11 \times 10^{-31}}} \\ &= \frac{12.27 \times 10^{-10}}{\sqrt{V}} \text{ meter (or)} \\ \lambda &= \frac{12.27}{\sqrt{V}} \text{ \AA} \end{aligned}$$

For example, if an electron is accelerated through a potential difference of 100V, then its de Broglie wavelength is 1.227 Å.

Since the kinetic energy of the electron, $K = eV$, then the de Broglie wavelength associated with electron can be also written as

$$\lambda = \frac{h}{\sqrt{2mK}} \quad (7.13)$$

7.3.4 Davisson – Germer experiment

De Broglie hypothesis of matter waves was experimentally confirmed by Clinton Davisson and Lester Germer in 1927. They demonstrated that electron beams are diffracted when they fall on crystalline solids. Since crystal can act as a three-dimensional diffraction grating for matter waves, the electron waves incident on crystals are diffracted off in certain specific directions. Figure 7.17 shows a schematic representation of the apparatus for the experiment.

The filament F is heated by a low tension (L.T.) battery. Electrons are emitted from the hot filament by thermionic emission. They are then accelerated due to the potential difference between the filament and the anode aluminium cylinder by a high tension (H.T.) battery. Electron beam is collimated by using two thin aluminium diaphragms and is allowed to strike a single crystal of Nickel.

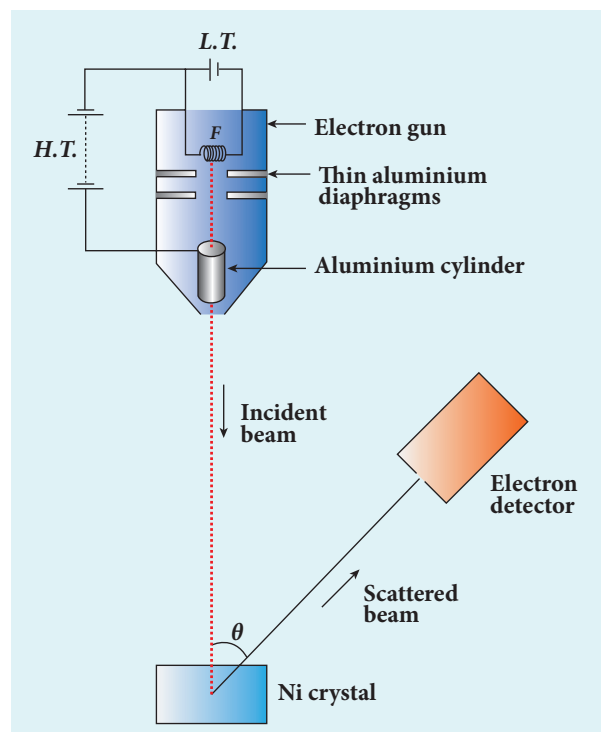

Figure 7.17 Experimental set up of Davisson – Germer experiment

The electrons scattered by Ni atoms in different directions are received by the electron detector which measures the intensity of scattered electron beam. The detector is rotatable in the plane of the paper so that the angle ϕ between the incident beam and the scattered beam can be changed at our will. The intensity of the scattered electron beam is measured as a function of the angle θ .

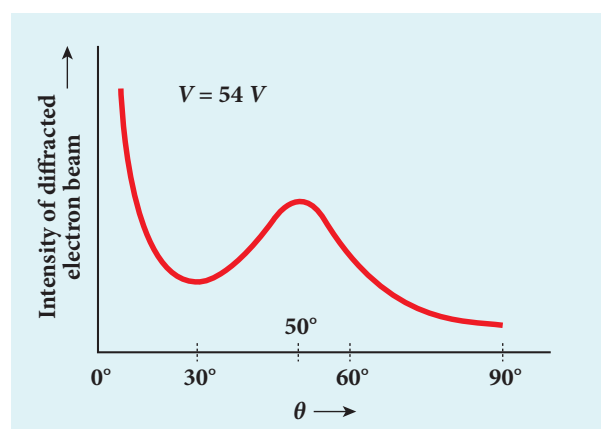

Figure 7.18 Variation of intensity of diffracted electron beam with the angle θ



Note

It is to be noted that electrons are not the only particles with which wave nature can be demonstrated. The particles like neutrons and alpha particle are also associated with waves. They undergo diffraction when they are scattered by suitable crystals. Neutron diffraction studies are highly useful for investigating crystal structures.

Note

Diffraction is one of the properties of waves. Whenever waves are incident on an obstacle, they bend around the edges of the obstacle. This bending of waves is called diffraction. The amount of bending depends on the wavelength of the waves.

We have learnt in unit 6 that as the wavelength of light is very small, diffraction effects of light are very small. In order to study diffraction of light, diffraction gratings are used.

Since X-rays and de Broglie waves of electrons have wavelengths (in the order of 10^{-10}m) much shorter than that of the light wave, diffraction grating cannot be used for their diffraction. In a crystal, the spacing between atomic planes is comparable to the wavelength of x-rays and de Broglie waves of electrons. Hence, for their diffraction, the crystals are used which serve as three-dimensional grating.

Figure 7.18 shows the variation of intensity of the scattered electrons with the angle θ for the accelerating voltage of 54V . For a given accelerating voltage V , the

scattered wave shows a peak or maximum at an angle of 50° to the incident electron beam. This peak in intensity is attributed to the constructive interference of electrons diffracted from various atomic layers of the target material. From the known value of interplanar spacing of Nickel, the wavelength of the electron wave has been experimentally calculated as 1.65\AA .

The wavelength can also be calculated from de Broglie relation for $V = 54\text{V}$ from equation (7.18) as

$$\lambda = \frac{12.27}{\sqrt{V}} \text{\AA} = \frac{12.27}{\sqrt{54}}$$

$$\lambda = 1.67 \text{\AA}$$

This value agrees well with the experimentally observed wavelength of 1.65\AA . Thus this experiment directly verifies de Broglie's hypothesis of the wave nature of moving particles.

7.3.5 Electron Microscope

Principle

This is the direct application of wave nature of particles. The wave nature of the electron is used in the construction of microscope called **electron microscope**.

The resolving power of a microscope is inversely proportional to the wavelength of the radiation used for illuminating the object under study. Higher magnification as well as higher resolving power can be obtained by employing the waves of shorter wavelengths.

De Broglie wavelength of electron is very much less than (a few thousands less) that of the visible light being used in optical microscopes. As a result, the microscopes employing de Broglie waves of electrons have very much higher resolving power than

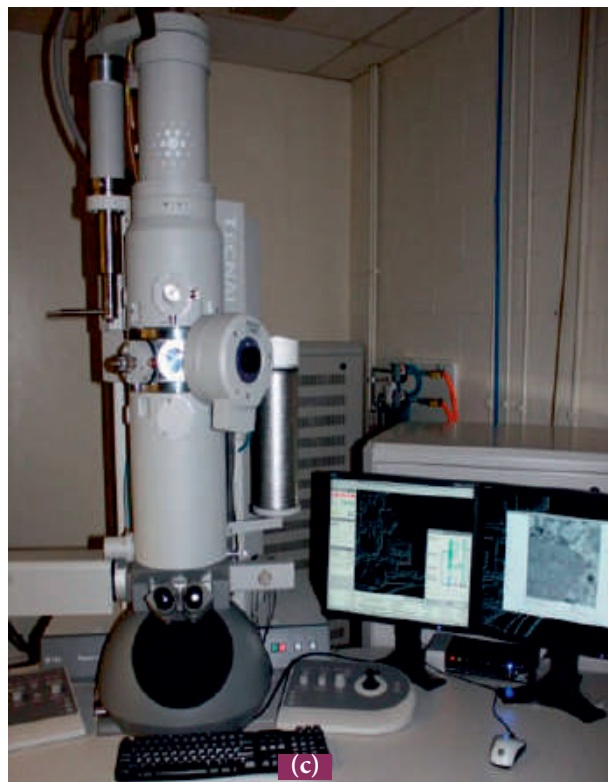
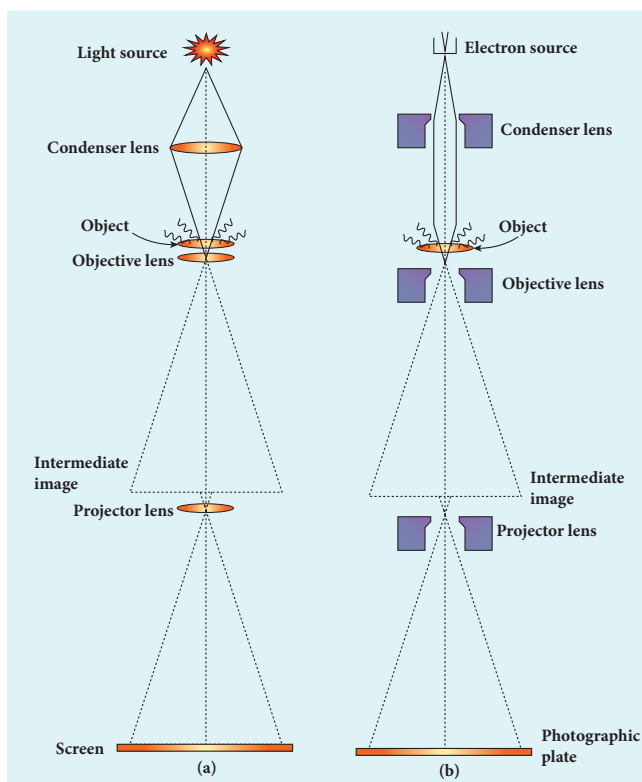

Figure 7.19 (a) Optical microscope (b) Electron microscope (c) Photograph of electron microscope

optical microscope. Electron microscopes giving magnification more than 2,00,000 times are common in research laboratories.

Working

The construction and working of an electron microscope is similar to that of an optical microscope except that in electron microscope focussing of electron beam is done by the electrostatic or magnetic lenses. The electron beam passing across a suitably arranged either electric or magnetic fields undergoes divergence or convergence thereby focussing of the beam is done (Figure 7.19).

The electrons emitted from the source are accelerated by high potentials. The beam is made parallel by magnetic condenser lens. When the beam passes through the sample whose magnified image is needed, the beam carries the image of the sample.

With the help of magnetic objective lens and magnetic projector lens system, the

magnified image is obtained on the screen. These electron microscopes are being used in almost all branches of science.

EXAMPLE 7.6

Calculate the momentum and the de Broglie wavelength in the following cases:

- an electron with kinetic energy 2 eV .
- a bullet of 50 g fired from rifle with a speed of 200 m/s
- a 4000 kg car moving along the highways at 50 m/s

Hence show that the wave nature of matter is important at the atomic level but is not really relevant at macroscopic level.

Solution:

- Momentum of the electron is

$$p = \sqrt{2mK} = \sqrt{2 \times 9.1 \times 10^{-31} \times 2 \times 1.6 \times 10^{-19}}$$

$$= 7.63 \times 10^{-25} \text{ kg ms}^{-1}$$

DO YOU KNOW?

Magnified images of some objects:



Coloured scanning electron micrograph of a common housefly (*Muscadomestica*).

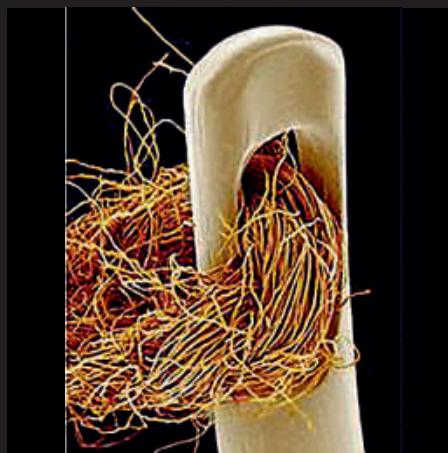

Needle and thread

Its de Broglie wavelength is

$$\lambda = \frac{h}{p} = \frac{6.626 \times 10^{-34}}{7.63 \times 10^{-25}} = 0.868 \times 10^{-9} \text{ m} \\ = 8.68 \text{ \AA}$$

ii) Momentum of the bullet is

$$p = mv = 0.050 \times 200 = 10 \text{ kgms}^{-1}$$

Its de Broglie wavelength is

$$\lambda = \frac{h}{p} = \frac{6.626 \times 10^{-34}}{10} = 6.626 \times 10^{-33} \text{ m}$$

iii) Momentum of the car is

$$p = mv = 4000 \times 50 = 2 \times 10^5 \text{ kgms}^{-1}$$

Its de Broglie wavelength is

$$\lambda = \frac{h}{p} = \frac{6.626 \times 10^{-34}}{2 \times 10^5} = 3.313 \times 10^{-39} \text{ m}$$

From these calculations, we notice that electron has significant value of de Broglie wavelength ($\approx 10^{-9} \text{ m}$ which can be measured from diffraction studies) but bullet and car have negligibly small de Broglie wavelengths associated with them ($\approx 10^{-33} \text{ m}$ and 10^{-39} m respectively, which are not measurable by any experiment). This implies that the wave nature of matter

is important at the atomic level but it is not really relevant at the macroscopic level.

EXAMPLE 7.7

Find the de Broglie wavelength associated with an alpha particle which is accelerated through a potential difference of 400 V. Given that the mass of the proton is $1.67 \times 10^{-27} \text{ kg}$.

Solution

An alpha particle contains 2 protons and 2 neutrons. Therefore, the mass M of the alpha particle is 4 times that of a proton (m_p) (or a neutron) and its charge q is twice that of a proton ($+e$).

The de Broglie wavelength associated with it is

$$\lambda = \frac{h}{\sqrt{2MqV}} = \frac{h}{\sqrt{2 \times (4m_p) \times (2e) \times V}} \\ = \frac{6.626 \times 10^{-34}}{\sqrt{2 \times 4 \times 1.67 \times 10^{-27} \times 2 \times 1.6 \times 10^{-19} \times 400}} \\ = \frac{6.626 \times 10^{-34}}{4 \times 20 \times 10^{-23} \sqrt{1.67 \times 1.6}} = 0.00507 \text{ \AA}$$

EXAMPLE 7.8

A proton and an electron have same de Broglie wavelength. Which of them moves faster and which possesses more kinetic energy?

Solution

We know that $\lambda = \frac{h}{\sqrt{2mK}}$

Since proton and electron have same de Broglie wavelength, we get

$$\frac{h}{\sqrt{2m_p K_p}} = \frac{h}{\sqrt{2m_e K_e}} \quad (\text{or}) \quad \frac{K_p}{K_e} = \frac{m_e}{m_p}$$

Since $m_e < m_p$, $K_p < K_e$, the electron has more kinetic energy than the proton.

$$\frac{K_p}{K_e} = \frac{\frac{1}{2}m_p v_p^2}{\frac{1}{2}m_e v_e^2} \quad (\text{or}) \quad \frac{v_p}{v_e} = \sqrt{\frac{K_p m_e}{K_e m_p}}$$

$$\frac{v_p}{v_e} = \sqrt{\frac{m_e^2}{m_p^2}} = \frac{m_e}{m_p} \quad \text{since} \quad \frac{K_p}{K_e} = \frac{m_e}{m_p}$$

Since $m_e < m_p$, $v_p < v_e$, the electron moves faster than the proton.

answers this question has already been discovered, even before Planck's quantum theory of radiation.

Discovery of x-rays

Wilhelm Roentgen in 1895 discovered that whenever fast moving electrons fall on certain materials, a highly penetrating radiation is emitted. Since their origin was not known at that time, they were called x-rays.

X-rays are electromagnetic waves of short wavelength ranging from 0.1 to 100Å. They travel along straight lines with the velocity of light and are not affected by electric and magnetic fields. X-ray photons are highly energetic because of its high frequency or short wavelength. Therefore, they can pass through materials which are opaque to visible light.

The quality of x-rays is measured in terms of their penetrating power which depends on the velocity with which the electrons strike the target material and the atomic number of target material. The intensity of x-rays is dependent on the number of electrons striking the target.

Production of x-rays

X-rays are produced in x-ray tube which is essentially a discharge tube as shown in Figure 7.20. A tungsten filament F is heated to incandescence by a battery. As a result, electrons are emitted from it by thermionic emission.

The electrons are accelerated to high speeds by the voltage applied between the filament F and the anode. The target materials like tungsten, molybdenum are embedded in the face of the solid copper anode. The face of the target is inclined at an angle with respect to the electron beam so that x-rays can leave the tube through its side.

7.4

X – RAYS

Introduction

Quantum theory of radiation explains photoelectric effect in which the electrons are emitted due to the incidence of photons and the energy is transferred from photons to the electrons. Immediately, a question arises: Is the reverse process also possible?

This means that whether electron kinetic energy can be transformed into photon energy or not. The phenomenon which

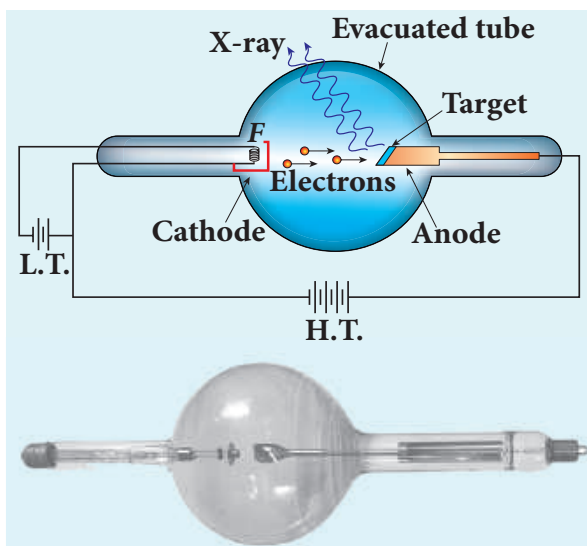

Figure 7.20 Production of x-rays

When high-speed electrons strike the target, they are decelerated suddenly and lose their kinetic energy. As a result, x-ray photons are produced. Since most of the kinetic energy of the bombarding electrons gets converted into heat, targets made of high-melting-point metals and a cooling system are usually employed.

X-ray spectra

X-rays are produced when fast moving electrons strike the metal target. The intensity of the x-rays when plotted against its wavelength gives a curve called **x-ray spectrum** (Figure 7.21(a) and (b)). X-ray spectra consist of two parts: a continuous spectrum and a series of peaks superimposed on it.

The **continuous spectrum** consists of radiations of all possible wavelengths with a certain minimum wavelength λ_0 which depends on the voltage across the electrodes. The peaks are characteristics of the material of the target and hence they are called **characteristic spectrum**. Figure 7.21(a) depicts the x-ray spectra of tungsten at various accelerating voltages and Figure 7.21(b) shows the x-ray spectra of tungsten and molybdenum at a particular accelerating voltage.

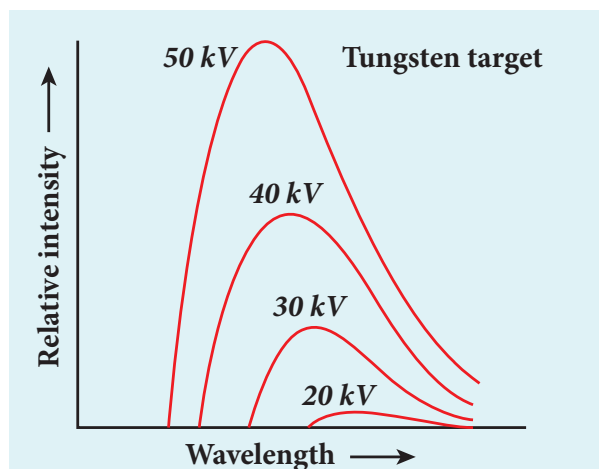

Figure 7.21 (a) X-ray spectra of tungsten at various accelerating potentials

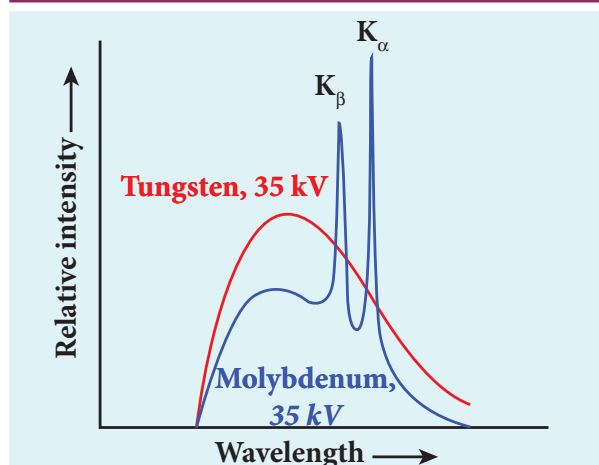

Figure 7.21 (b) X-ray spectra of tungsten and molybdenum at 35 kV accelerating potential

Though classical electromagnetic theory suggests the emission of radiations from accelerating electrons, it could not explain two features exhibited by x-ray spectra. These features are given below.

- (i) For a given accelerating voltage, the lower limit for the wavelength of continuous x-ray spectra is same for all targets. This minimum wavelength is called cut-off wavelength.
- (ii) The intensity of x-rays is significantly increased at certain well-defined wavelengths as shown in the case of characteristic x-ray spectra for molybdenum (Figure 7.21(b)).

But these two features could be explained on the basis of photon theory of radiation.

Continuous x-ray spectra

When a fast moving electron penetrates and approaches a target nucleus, the interaction between the electron and the nucleus either accelerates or decelerates it which results in a change of path of the electron. The radiation produced from such decelerating electron is called **Bremsstrahlung or braking radiation** (Figure 7.22).

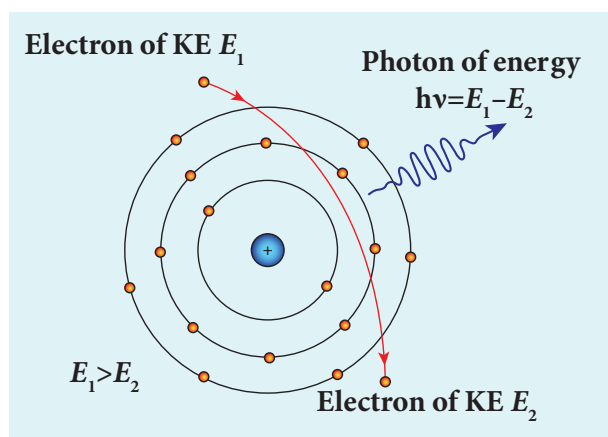

Figure 7.22 Bremsstrahlung photon from a decelerating electron

The energy of the photon emitted is equal to the loss of kinetic energy of the electron. Since an electron may lose part or all of its energy to the photon, the photons are emitted with all possible energies (or frequencies). The continuous x-ray spectrum is due to such radiations.

When an electron gives up all its energy, then the photon is emitted with highest frequency ν_0 (or lowest wavelength λ_0). The initial kinetic energy of an electron is given by eV where V is the accelerating voltage. Therefore, we have

$$h\nu_0 = eV \quad (\text{or}) \quad \frac{hc}{\lambda_0} = eV$$

$$\lambda_0 = \frac{hc}{eV}$$

where λ_0 is the cut-off wavelength. Substituting the known values in the above equation, we get

$$\lambda_0 = \frac{12400}{V} \text{ \AA} \quad (7.14)$$

The relation given by equation (7.14) is known as the **Duane – Hunt formula**.

The value of λ_0 depends only on the accelerating potential and is same for all targets. This is in good agreement with the experimental results. Thus, the production of continuous x-ray spectrum and the origin of cut – off wavelength can be explained on the basis of photon theory of radiation.

Characteristic x – ray spectra:

X – ray spectra show some narrow peaks at some well – defined wavelengths when the target is hit by fast electrons. The line spectrum showing these peaks is called **characteristic x – ray spectrum**. This x – ray spectrum is due to the electronic transitions within the atoms.

When an energetic electron penetrates into the target atom and removes some of the *K*-shell electrons. Then the electrons from outer orbits jump to fill up the vacancy so created in the *K*-shell. During the downward transition, the energy difference between the levels is given out in the form of x– ray photon of definite wavelength. Such wavelengths, characteristic of the target, constitute the line spectrum.

From the Figure 7.23, it is evident that *K*-series of lines in the x-ray spectrum of an element arises due to the electronic transitions from *L*, *M*, *N*, . . . levels to the *K*-level. Similarly, the longer wavelength *L*-series originates when an *L*-electron is knocked out of the atom and the corresponding vacancy is filled by the

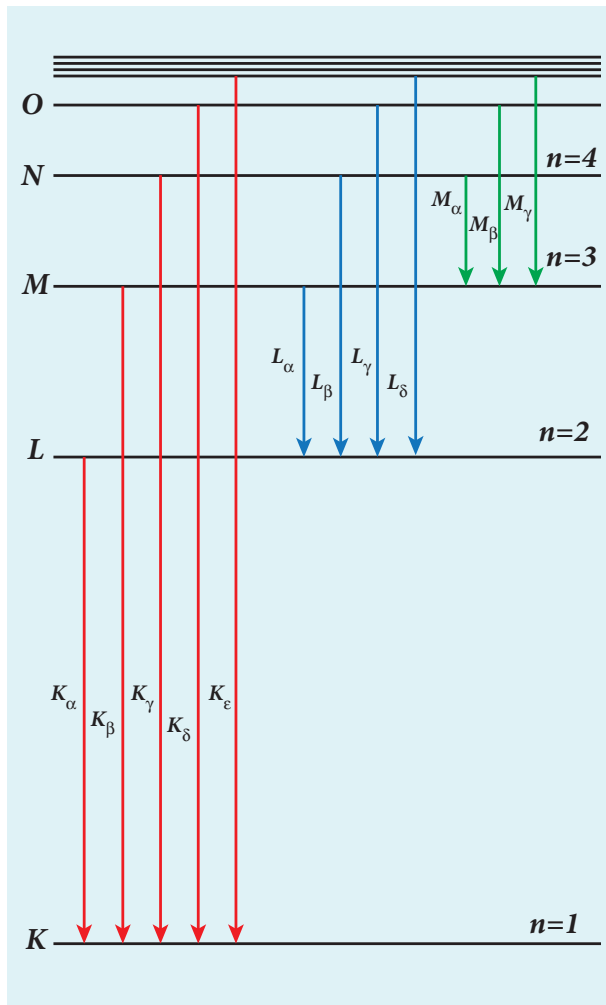

Figure 7.23 Origin of characteristic x-ray spectra

electronic transitions from M , N , O ,... and so on.

The K_α and K_β of the K -series of molybdenum are shown by the two peaks in its x-ray spectrum in Figure 7.21(b).

Applications of x-rays:

X-rays are being used in many fields. Let us list a few of them.

1) Medical diagnosis

X-rays can pass through flesh more easily than through bones. Thus an x-ray

radiograph containing a deep shadow of the bones and a light shadow of the flesh may be obtained. X-ray radiographs are used to detect fractures, foreign bodies, diseased organs etc.

2) Medical therapy

Since x-rays can kill diseased tissues, they are employed to cure skin diseases, malignant tumours etc.

3) Industry

X-rays are used to check for flaws in welded joints, motor tyres, tennis balls and wood. At the custom post, they are used for detection of contraband goods.

4) Scientific research

X-ray diffraction is important tool to study the structure of the crystalline materials – that is, the arrangement of atoms and molecules in crystals.

EXAMPLE 7.9

Calculate the cut-off wavelength and cut-off frequency of x-rays from an x-ray tube of accelerating potential 20,000 V.

Solution

The cut-off wavelength of the characteristic x-rays is

$$\lambda_0 = \frac{12400}{V} \text{ \AA} = \frac{12400}{20000} \text{ \AA} \\ = 0.62 \text{ \AA}$$

The corresponding frequency is

$$\nu_0 = \frac{c}{\lambda_0} = \frac{3 \times 10^8}{0.62 \times 10^{-10}} = 4.84 \times 10^{18} \text{ Hz}$$

SUMMARY

- Particle is a material object which is considered as a tiny concentration of matter (localized in space and time) whereas wave is a broad distribution of energy (not localized in space and time).
- The liberation of electrons from any surface of a substance is called electron emission.
- The minimum energy needed for an electron to escape from the metal surface is called work function of that metal.
- 1 eV is equal to $1.602 \times 10^{-19}\text{ J}$.
- The emission of electrons by supplying thermal energy is known as thermionic emission.
- Electric field emission occurs when a very strong electric field is applied across the metal.
- The emission of electrons due to irradiation of light is called photoelectric emission.
- Secondary emission is the process in which electrons are emitted due to the bombardment of fast moving electrons.
- The photoelectric current (i.e. the number of electrons emitted per second) is directly proportional to the intensity of the incident light.
- Stopping potential is that the value of the negative (retarding) potential given to the collecting electrode A which is just sufficient to stop the most energetic photoelectrons emitted and make the photocurrent zero.
- The stopping potential is independent of intensity of the incident light.
- Maximum kinetic energy of the photoelectrons is independent of intensity of the incident light.
- For a given surface, the emission of photoelectrons takes place only if the frequency of incident light is greater than a certain minimum frequency called the threshold frequency.
- According to Planck, a matter is composed of a large number of oscillating particles (atoms) which vibrate with different frequencies.
- According to Einstein, the energy in light is not spread out over wavefronts but is concentrated in small packets or energy quanta.
- The individual light quantum of definite energy and momentum can be associated with a particle. This particle is named photon.
- Light behaves as a wave during its propagation and behaves as a particle during its interaction with matter.
- Photo electric cell or photo cell is a device which converts light energy into electrical energy.
- According to de Broglie hypothesis, all matter particles like electrons, protons, neutrons in motion are associated with waves. These waves are called de Broglie waves or matter waves.
- Wave nature of the electron is used in the construction of microscope called electron microscope.

- De Broglie hypothesis of matter waves was experimentally confirmed by Clinton Davisson and Lester Germer in 1927.
- Whenever fast moving electrons fall on the materials, a highly penetrating radiation, x-rays, is emitted.
- Continuous x-ray spectrum consists of radiations of all possible wavelengths with a certain minimum wavelength λ_0 .
- Characteristic x-ray spectra show some narrow peaks at some well – defined wavelengths when the target is hit by fast electrons.

CONCEPT MAP

Dual nature of radiation and matter

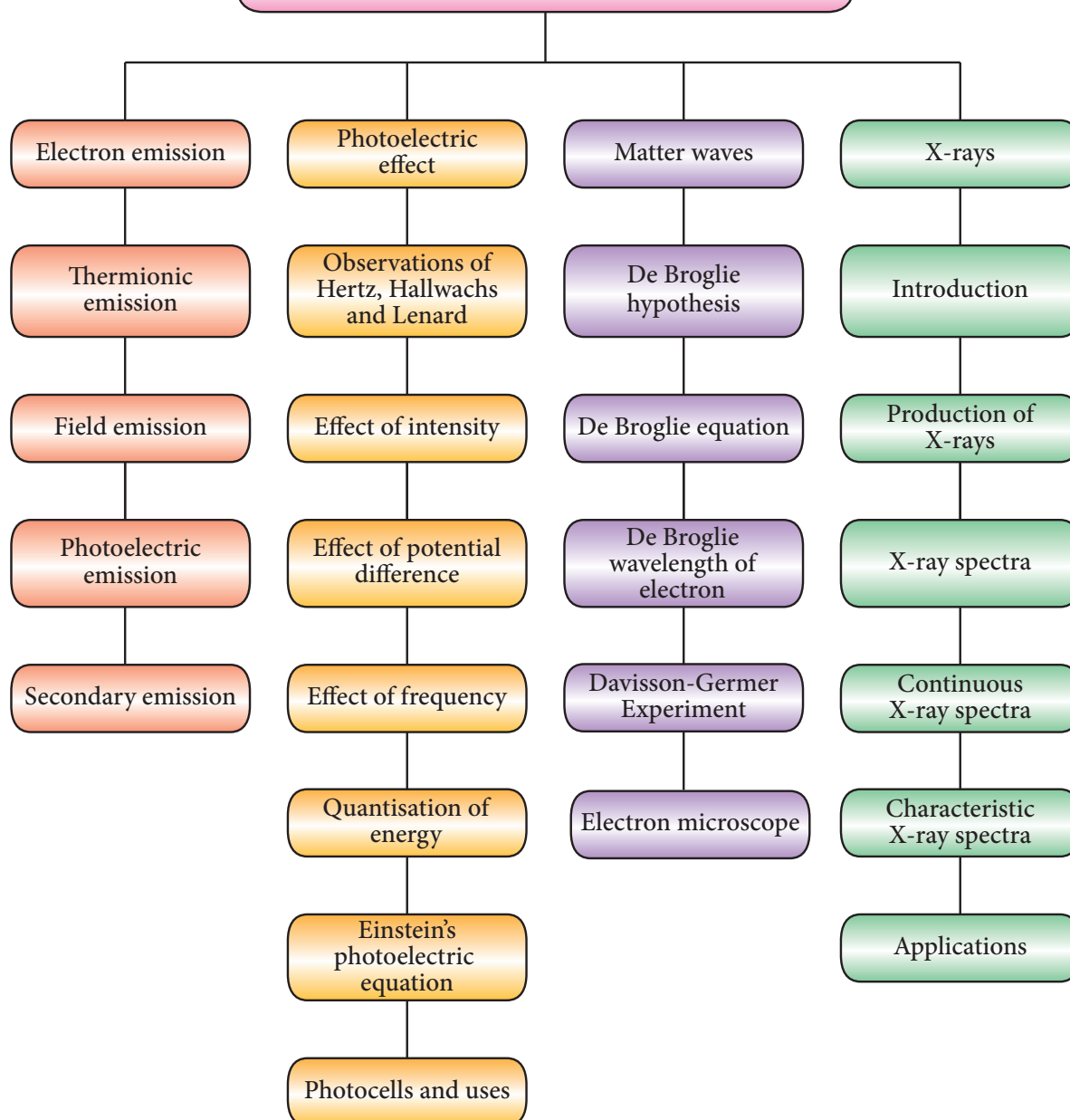



I Multiple Choice Questions

1. The wavelength λ_e of an electron and λ_p of a photon of same energy E are related by (NEET 2013)

a. $\lambda_p \propto \lambda_e$ b. $\lambda_p \propto \sqrt{\lambda_e}$
 c. $\lambda_p \propto \frac{1}{\sqrt{\lambda_e}}$ d. $\lambda_p \propto \lambda_e^2$

2. In an electron microscope, the electrons are accelerated by a voltage of 14 kV . If the voltage is changed to 224 kV , then the de Broglie wavelength associated with the electrons would

- a. increase by 2 times
 b. decrease by 2 times
 c. decrease by 4 times
 d. increase by 4 times



3. A particle of mass $3 \times 10^{-6} \text{ g}$ has the same wavelength as an electron moving with a velocity $6 \times 10^6 \text{ m s}^{-1}$. The velocity of the particle is

- a. $1.82 \times 10^{-18} \text{ m s}^{-1}$
 b. $9 \times 10^{-2} \text{ m s}^{-1}$
 c. $3 \times 10^{-31} \text{ m s}^{-1}$
 d. $1.82 \times 10^{-15} \text{ m s}^{-1}$

4. When a metallic surface is illuminated with radiation of wavelength λ , the stopping potential is V . If the same surface is illuminated with radiation of wavelength 2λ , the stopping potential is $\frac{V}{4}$. The threshold wavelength for the metallic surface is (NEET 2016)

- a. 4λ b. 5λ
 c. $\frac{5}{2}\lambda$ d. 3λ

5. If a light of wavelength 330 nm is incident on a metal with work function 3.55 eV , the electrons are emitted. Then the wavelength of the emitted electron is (Take $h = 6.6 \times 10^{-34} \text{ Js}$)

- a. $< 2.75 \times 10^{-9} \text{ m}$ b. $\geq 2.75 \times 10^{-9} \text{ m}$
 c. $\leq 2.75 \times 10^{-12} \text{ m}$ d. $< 2.5 \times 10^{-10} \text{ m}$

6. A photoelectric surface is illuminated successively by monochromatic light of wavelength λ and $\frac{\lambda}{2}$. If the maximum kinetic energy of the emitted photoelectrons in the second case is 3 times that in the first case, the work function at the surface of material is (NEET 2015)

- a) $\frac{hc}{\lambda}$ b) $\frac{2hc}{\lambda}$
 c) $\frac{hc}{3\lambda}$ d) $\frac{hc}{2\lambda}$

7. In photoelectric emission, a radiation whose frequency is 4 times threshold frequency of a certain metal is incident on the metal. Then the maximum possible velocity of the emitted electron will be

- a) $\sqrt{\frac{hv_0}{m}}$ b) $\sqrt{\frac{6hv_0}{m}}$
 c) $2\sqrt{\frac{hv_0}{m}}$ d) $\sqrt{\frac{hv_0}{2m}}$

8. Two radiations with photon energies 0.9 eV and 3.3 eV respectively are falling on a metallic surface successively. If the work function of the metal is 0.6 eV , then the ratio of maximum speeds of emitted electrons will be

- a) 1:4 b) 1:3
 c) 1:1 d) 1:9

9. A light source of wavelength 520 nm emits 1.04×10^{15} photons per second while the second source of 460 nm produces 1.38×10^{15} photons per second. Then the ratio of power of second source to that of first source is

- a) 1.00 b) 1.02
c) 1.5 d) 0.98

10. The mean wavelength of light from sun is taken to be 550 nm and its mean power is $3.8 \times 10^{26} \text{ W}$. The number of photons received by the human eye per second on the average from sunlight is of the order of

- a) 10^{45} b) 10^{42}
c) 10^{54} d) 10^{51}

11. The threshold wavelength for a metal surface whose photoelectric work function is 3.313 eV is

- a) 4125 \AA b) 3750 \AA
c) 6000 \AA d) 2062.5 \AA

12. A light of wavelength 500 nm is incident on a sensitive plate of photoelectric work function 1.235 eV . The kinetic energy of the photo electrons emitted is be (Take $h = 6.6 \times 10^{-34} \text{ Js}$)

- a) 0.58 eV b) 2.48 eV
c) 1.24 eV d) 1.16 eV

13. Photons of wavelength λ are incident on a metal. The most energetic electrons ejected from the metal are bent into a circular arc of radius R by a perpendicular magnetic field having magnitude B . The work function of the metal is (KVPY-SX 2016)

a. $\frac{hc}{\lambda} - m_e c^2 + \frac{e^2 B^2 R^2}{2m_e}$

b. $\frac{hc}{\lambda} + 2m_e \left[\frac{eBR}{2m_e} \right]^2$

c. $\frac{hc}{\lambda} - m_e c^2 - \frac{e^2 B^2 R^2}{2m_e}$

d. $\frac{hc}{\lambda} - 2m_e \left[\frac{eBR}{2m_e} \right]^2$

14. The work functions for metals A , B and C are 1.92 eV , 2.0 eV and 5.0 eV respectively. The metals which will emit photoelectrons for a radiation of wavelength 4100 \AA is/are

- a. A only
b. both A and B
c. all these metals
d. none

15. Emission of electrons by the absorption of heat energy is called.....emission.

- a. photoelectric
b. field
c. thermionic
d. secondary

Answers

1. d 2. c 3. d 4. d 5. b
6. d 7. b 8. b 9. c 10. a
11. b 12. c 13. d 14. b 15. c

II Short Answer Questions

- Why do metals have a large number of free electrons?
- Define work function of a metal. Give its unit.
- What is photoelectric effect?
- How does photocurrent vary with the intensity of the incident light?
- Give the definition of intensity of light and its unit.
- How will you define threshold frequency?

7. What is a photo cell? Mention the different types of photocells.
8. Write the expression for the de Broglie wavelength associated with a charged particle of charge q and mass m , when it is accelerated through a potential V .
9. State de Broglie hypothesis.
10. Why we do not see the wave properties of a baseball?
11. A proton and an electron have same kinetic energy. Which one has greater de Broglie wavelength. Justify.
12. Write the relationship of de Broglie wavelength λ associated with a particle of mass m in terms of its kinetic energy K .
13. Name an experiment which shows wave nature of the electron. Which phenomenon was observed in this experiment using an electron beam?
14. An electron and an alpha particle have same kinetic energy. How are the de Broglie wavelengths associated with them related?

III Long Answer Questions

1. What do you mean by electron emission? Explain briefly various methods of electron emission.
2. Briefly discuss the observations of Hertz, Hallwachs and Lenard.
3. Explain the effect of potential difference on photoelectric current.
4. Explain how frequency of incident light varies with stopping potential.
5. List out the laws of photoelectric effect.
6. Explain why photoelectric effect cannot be explained on the basis of wave nature of light.
7. Explain the quantum concept of light.
8. Obtain Einstein's photoelectric equation with necessary explanation.
9. Explain experimentally observed facts of photoelectric effect with the help of Einstein's explanation.
10. Give the construction and working of photo emissive cell.
11. Derive an expression for de Broglie wavelength of electrons.
12. Briefly explain the principle and working of electron microscope.
13. Describe briefly Davisson – Germer experiment which demonstrated the wave nature of electrons.

IV. Numerical problems

1. How many photons per second emanate from a 50 mW laser of 640 nm ?
[Ans: $1.61 \times 10^{17}\text{ s}^{-1}$]
2. Calculate the maximum kinetic energy and maximum velocity of the photoelectrons emitted when the stopping potential is 81 V for the photoelectric emission experiment.
[[Ans: $1.3 \times 10^{-17}\text{ J}$; $5.3 \times 10^6\text{ ms}^{-1}$]]
3. Calculate the energies of the photons associated with the following radiation: (i) violet light of 413 nm (ii) X-rays of 0.1 nm (iii) radio waves of 10 m .
[Ans: 3 eV ; 12424 eV ; $1.24 \times 10^{-7}\text{ eV}$]
4. A 150 W lamp emits light of mean wavelength of 5500 \AA . If the efficiency is 12% , find out the number of photons emitted by the lamp in one second.
[Ans: 4.98×10^{19}]
5. How many photons of frequency 10^{14} Hz will make up 19.86 J of energy?
[Ans: 3×10^{20}]

6. What should be the velocity of the electron so that its momentum equals that of 4000 \AA wavelength photon.
[Ans: 1818 ms^{-1}]
7. When a light of frequency $9 \times 10^{14} \text{ Hz}$ is incident on a metal surface, photoelectrons are emitted with a maximum speed of $8 \times 10^5 \text{ ms}^{-1}$. Determine the threshold frequency of the surface.
[Ans: $4.61 \times 10^{14} \text{ Hz}$]
8. When a 6000 \AA light falls on the cathode of a photo cell and produced photoemission. If a stopping potential of 0.8 V is required to stop emission of electron, then determine the (i) frequency of the light (ii) energy of the incident photon (iii) work function of the cathode material (iv) threshold frequency and (v) net energy of the electron after it leaves the surface.
[Ans: $5 \times 10^{14} \text{ Hz}$; 2.07 eV ; 1.27 eV ; $3.07 \times 10^{14} \text{ Hz}$; 0.8 eV]
9. A 3310 \AA photon liberates an electron from a material with energy $3 \times 10^{-19} \text{ J}$ while another 5000 \AA photon ejects an electron with energy $0.972 \times 10^{-19} \text{ J}$ from the same material. Determine the value of Planck's constant and the threshold wavelength of the material.
[Ans: $6.62 \times 10^{-34} \text{ Js}$; $6620 \times 10^{-10} \text{ m}$]
10. At the given point of time, the earth receives energy from sun at $4 \text{ cal cm}^{-2} \text{ min}^{-1}$. Determine the number of photons received on the surface of the Earth per cm^2 per minute. (Given : Mean wavelength of sun light = 5500 \AA)
[Ans: 4.65×10^{19}]
11. UV light of wavelength 1800 \AA is incident on a lithium surface whose threshold wavelength 4965 \AA . Determine the maximum energy of the electron emitted.
[Ans: 4.40 eV]
12. Calculate the de Broglie wavelength of a proton whose kinetic energy is equal to $81.9 \times 10^{-15} \text{ J}$. (Given: mass of proton is 1836 times that of electron).
[Ans: $4 \times 10^{-14} \text{ m}$]
13. A deuteron and an alpha particle are accelerated with the same potential. Which one of the two has i) greater value of de Broglie wavelength associated with it and ii) less kinetic energy? Explain.
[Ans: $\lambda_d = 2\lambda_\alpha$ and $K_d = \frac{K_\alpha}{2}$]
14. An electron is accelerated through a potential difference of 81 V . What is the de Broglie wavelength associated with it? To which part of electromagnetic spectrum does this wavelength correspond?
[Ans: $\lambda = 1.36 \text{ \AA}$ and x-rays]
15. The ratio between the de Broglie wavelengths associated with protons, accelerated through a potential of 512 V and that of alpha particles accelerated through a potential of X volts is found to be one. Find the value of X .
[Ans: 64 V]



BOOK FOR REFERENCES

1. Arthur Beiser, Shobhit Mahajan, Rai Choudhury, *Concepts of Modern Physics*, Sixth Edition, McGraw Hill Education (India) Private Limited.
2. H.S. Mani and G.K. Mehta, *Introduction to Modern Physics*, Affiliated East-West Press Pvt. Ltd.
3. H.C.Verma, *Concepts of Physics*, Volume 1 and 2, BharathiBhawan publishers.
4. Halliday, Resnick and Walker, *Principles of Physics*, Wiley publishers.





ICT CORNER

Dual nature of radiation and matter



In this activity you will be able to visualize how light knocks electrons off a metal target and describe the photoelectric effect experiment.

Topic: Photoelectric effect

STEPS:

- Open the browser and type “<https://phet.colorado.edu/en/simulation/legacy/photoelectric>” in the address bar.
- Change intensity of light and observe how the intensity of light will affect the photo electric current and the energy of electrons
- By adjusting the value of wavelength and observe how the wavelength of light will affect the photo electric current and the energy of electrons
- Adjust the value of voltage from the battery and analyse the effect of potential difference on the photoelectric current.
- Change the material of the target and analyse how it will affect the current and the energy of electrons.
- Study the photo electric current – voltage graph and Photo electric current - intensity graph obtained from this experiment.

Step1

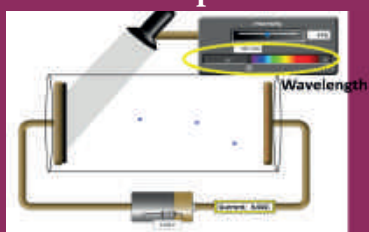

Step2

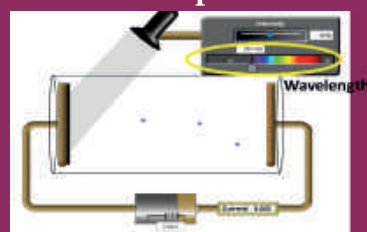

Step3



Step4

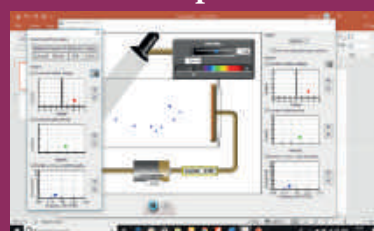

Note:

Install Java application if it is not in your browser.

You can download all the phet simulation and works in off line from <https://phet.colorado.edu/en/offline-access> .

URL:

<https://phet.colorado.edu/en/simulation/legacy/photoelectric>

* Pictures are indicative only.

* If browser requires, allow **Flash Player** or **Java Script** to load the page.



B263_12_PHYSICS_EM

UNIT 8

ATOMIC AND NUCLEAR PHYSICS

All of physics is either impossible or trivial. It is impossible until you understand it, and then it becomes trivial

– Ernest Rutherford

LEARNING OBJECTIVES

In this unit, the students are exposed to

- electric discharge through the gases
- determination of specific charge by J.J. Thomson experiment
- determination of electronic charge by Millikan's oil drop experiment
- atom models – J.J. Thomson and Rutherford
- Bohr atom model and hydrogen atom
- atomic spectrum and hydrogen spectrum
- structure and properties of nucleus
- various classification of nuclei based on atomic and mass number
- mass defect and binding energy
- relation between stability and binding energy curve
- alpha, beta and gamma decay
- law of radioactive decay
- nuclear fission and fusion
- elementary ideas of nuclear reactors
- qualitative idea of elementary particles



8.1

INTRODUCTION

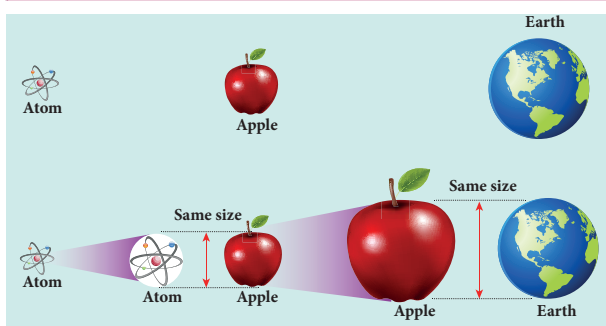

Figure 8.1 Comparison of size of an atom with that of an apple and comparison of size of an apple with that of the Earth

In earlier classes, we have studied that anything which occupies space is called matter. Matter can be classified into solids, liquids and gases. In our daily life, we use water for drinking, petrol for vehicles, we inhale oxygen, stainless steel vessels for cooking, etc. Experiences tell us that behaviour of one material is not same as another, this means that the physical and chemical properties are different for different materials. In order to understand this, we need to know the fundamental constituents of materials.

When an object is divided repeatedly, the process of division could not be done beyond a certain stage in a similar way and we end up with a small speck. This small speck was defined as an atom. The word atom in Greek means ‘without division or indivisible’. The size of an atom is very very small. For an example, the size of hydrogen atom (simplest among other atoms) is around 10^{-10} m. An American Physicist Richard P. Feynman said that if the atom becomes the size of an apple, then the apple becomes the size of the earth as shown in Figure 8.1. Such a small entity is an atom.

In this unit, we first discuss the theoretical models of atom to understand its structure. The Bohr atom model is more successful than J. J. Thomson and Rutherford atom models. It explained many unsolved issues in those days and also gave better understanding of chemistry.

Later, scientists observed that even the atom is not the fundamental entity. It consists of electrons and nucleus. Around 1930, scientists discovered that nucleus is also made of proton and neutron. Further research discovered that even the proton and neutron are made up of fundamental entities known as quarks.

In this context, the remaining part of this unit is written to understand the structure and basic properties of nucleus. Further how the nuclear energy is produced and utilized are discussed.

8.2

ELECTRIC DISCHARGE THROUGH GASES

Gases at normal atmospheric pressure are poor conductors of electricity because they do not have free electrons for conduction.

But by special arrangement, one can make a gas to conduct electricity.

A simple and convenient device used to study the conduction of electricity through gases is known as gas discharge tube. The arrangement of discharge tube is shown in Figure 8.2. It consists of a long closed glass tube (of length nearly 50 cm and diameter of 4 cm) inside of which the gas in pure form is filled usually. The small opening in the tube is connected to a high vacuum pump and a low-pressure gauge. This tube is fitted with two metallic plates known as electrodes which are connected to secondary of an induction coil. The electrode connected to positive of secondary is known as anode and the electrode to the negative of the secondary is cathode. The potential of secondary is maintained about 50 kV.

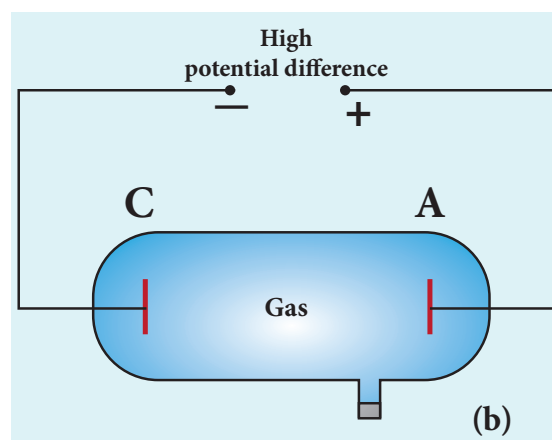

Figure 8.2 Discharge tube (a) real picture (b) schematic diagram

Suppose the pressure of the gas in discharge tube is reduced to around 110 mm of Hg using vacuum pump, it is observed that no discharge takes place. When the pressure is kept near 100 mm of Hg, the discharge of electricity through the tube takes place. Consequently, irregular streaks of light appear and also crackling sound is produced. When the pressure is reduced to the order of 10 mm of Hg, a luminous column known as positive column is formed from anode to cathode.

When the pressure reaches to around 0.01 mm of Hg, positive column disappears. At this time, a dark space is formed between anode and cathode which is often called Crooke's dark space and the walls of the tube appear with green colour. At this stage, some invisible rays emanate from cathode called cathode rays, which are later found to be a beam of electrons.

Properties of cathode rays

(1) Cathode rays possess energy and momentum and travel in a straight line with high speed of the order of 10^7 m s^{-1} . It can be deflected by application of electric and magnetic fields. The direction of deflection indicates that they are negatively charged particles.

(2) When the cathode rays are allowed to fall on matter, they produce heat. They affect the photographic plates and also produce fluorescence when they fall on certain crystals and minerals.

(3) When the cathode rays fall on a material of high atomic weight, x-rays are produced.

(4) Cathode rays ionize the gas through which they pass.

(5) The speed of cathode rays is up to $\left(\frac{1}{10}\right)^{\text{th}}$ of the speed of light.

8.2.1 Determination of specific charge $\left(\frac{e}{m}\right)$ of an electron – Thomson's experiment

Thomson's experiment is considered as one among the landmark experiments for the birth of modern physics. In 1887, J. J. Thomson made remarkable improvement in the scope of study of gases in discharge tubes. In the presence of electric and magnetic fields, the cathode rays are deflected. By the variation of electric and magnetic fields, mass normalized charge or the specific charge (charge per unit mass) of the cathode rays is measured.

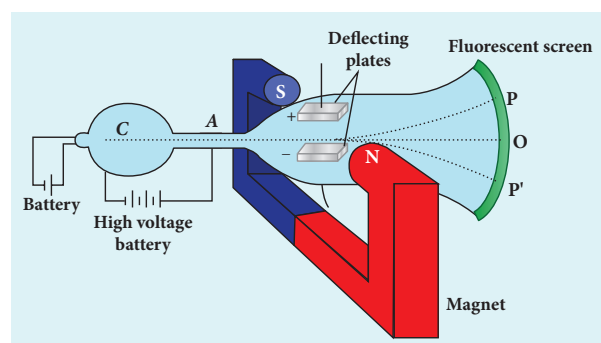

Figure 8.3 Arrangement of J.J. Thomson experiment to determine the specific charge of an electron

The arrangement of J. J. Thomson's experiment is shown in Figure 8.3. A highly evacuated discharge tube is used and cathode rays (electron beam) produced at cathode are attracted towards anode disc A. Anode disc is made with pin hole in order to allow only a narrow beam of cathode rays. These cathode rays are now allowed to pass through the parallel metal plates, maintained at high voltage as shown in Figure 8.3. Further, this gas discharge tube is kept in between pole pieces of magnet such that both electric and magnetic fields are perpendicular to each other. When the cathode rays strike the screen, they produce scintillation and hence bright spot

is observed. This is achieved by coating the screen with zinc sulphide.

(i) Determination of velocity of cathode rays

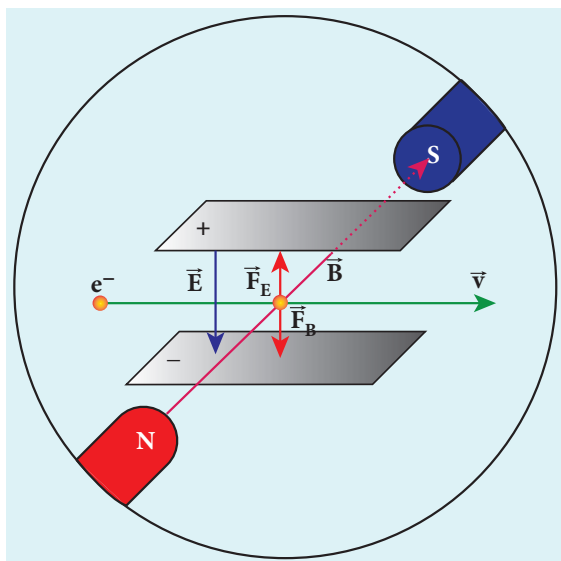

Figure 8.4 Electric force balancing the magnetic force – the path of electron beam is a straight line

For a fixed electric field between the plates, the magnetic field is adjusted such that the cathode rays (electron beam) strike at the original position O (Figure 8.3). This means that the magnitude of electric force is balanced by the magnitude of force due to magnetic field as shown in Figure 8.4. Let e be the charge of the cathode rays, then

$$eE = eBv$$

$$\Rightarrow v = \frac{E}{B} \quad (8.1)$$

(ii) Determination of specific charge

Since the cathode rays (electron beam) are accelerated from cathode to anode, the potential energy of the electron beam at the cathode is converted into kinetic energy of the electron beam at the anode. Let V be the potential difference between anode and cathode, then the potential energy is eV . Then from law of conservation of energy,

$$eV = \frac{1}{2}mv^2 \Rightarrow \frac{e}{m} = \frac{v^2}{2V}$$

Substituting the value of velocity from equation (8.1), we get

$$\frac{e}{m} = \frac{1}{2V} \frac{E^2}{B^2} \quad (8.2)$$

Substituting the values of E , B and V , the specific charge can be determined as

$$\frac{e}{m} = 1.7 \times 10^{11} \text{ C kg}^{-1}$$

(iii) Deflection of charge only due to uniform electric field

When the magnetic field is turned off, the deflection is only due to electric field. The deflection in vertical direction is due to the electric force.

$$F_e = eE \quad (8.3)$$

Let m be the mass of the electron and by applying Newton's second law of motion, acceleration of the electron is

$$a_e = \frac{1}{m} F_e \quad (8.4)$$

Substituting equation (8.4) in equation (8.3),

$$a_e = \frac{1}{m} eE = \frac{e}{m} E$$

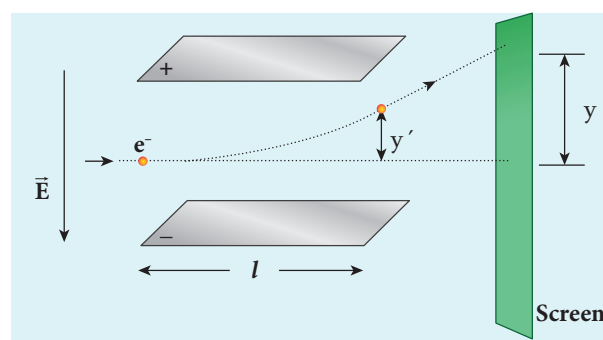

Figure 8.5 Deviation of path by applying uniform electric field

Let y be the deviation produced from original position on the screen as shown in Figure 8.5. Let the initial upward velocity of cathode ray be $u=0$ before entering the parallel electric plates. Let t be the time taken by the cathode rays to travel in electric field. Let l be the length of one of the plates, then the time taken is

$$t = \frac{l}{v} \quad (8.5)$$

Hence, the deflection y' of cathode rays is (note: $u=0$ and $a_e = \frac{e}{m}E$)

$$\begin{aligned} y' &= ut + \frac{1}{2}at^2 \Rightarrow y' = ut + \frac{1}{2}a_e t^2 \\ &= \frac{1}{2} \left(\frac{e}{m}E \right) \left(\frac{l}{v} \right)^2 \end{aligned}$$

$$y' = \frac{1}{2} \frac{e}{m} \frac{l^2 B^2}{E} \quad (8.6)$$

Therefore, the deflection y on the screen is

$$y \propto y' \Rightarrow y = C y'$$

where C is proportionality constant which depends on the geometry of the discharge tube and substituting y' value in equation 8.6, we get

$$y = C \frac{1}{2} \frac{e}{m} \frac{l^2 B^2}{E} \quad (8.7)$$

Rearranging equation (8.7) as

$$\frac{e}{m} = \frac{2yE}{Cl^2 B^2} \quad (8.8)$$

Substituting the values on RHS, the value of specific charge is calculated as $\frac{e}{m} = 1.7 \times 10^{11} \text{ C kg}^{-1}$

(iv) Deflection of charge only due to uniform magnetic field

Suppose that the electric field is switched off and only the magnetic field is switched on. Now the deflection occurs only due to magnetic field. The force experienced by the electron in uniform magnetic field applied perpendicular to its path is

$$F_m = e v B \quad (\text{in magnitude})$$

Since this force provides the centripetal force, the electron beam undergoes a semi-circular path. Therefore, we can equate F_m to centripetal force $\frac{mv^2}{R}$.

$$F_m = e v B = m \frac{v^2}{R}$$

where v is the velocity of electron beam at the point where it enters the magnetic field and R is the radius of the circular path traversed by the electron beam.

$$eB = m \frac{v}{R} \Rightarrow \frac{e}{m} = \frac{v}{BR} \quad (8.9)$$

Further, substituting equation (8.1) in equation (8.10), we get

$$\frac{e}{m} = \frac{E}{B^2 R} \quad (8.10)$$

By knowing the values of electric field, magnetic field and the radius of circular path, the value of specific charge $\left(\frac{e}{m}\right)$ can be calculated, which is also consistent with other two methods.



The specific charge is independent of
(a) gas used
(b) nature of the electrodes

8.2.2 Determination of charge of an electron – Millikan's oil drop experiment

Millikan's oil drop experiment is another important experiment in modern physics which is used to determine one of the fundamental constants of nature known as charge of an electron (Figure 8.6 (a)).

By adjusting electric field suitably, the motion of oil drop inside the chamber can be controlled – that is, it can be made to move up or down or even kept balanced in the field of view for sufficiently long time.

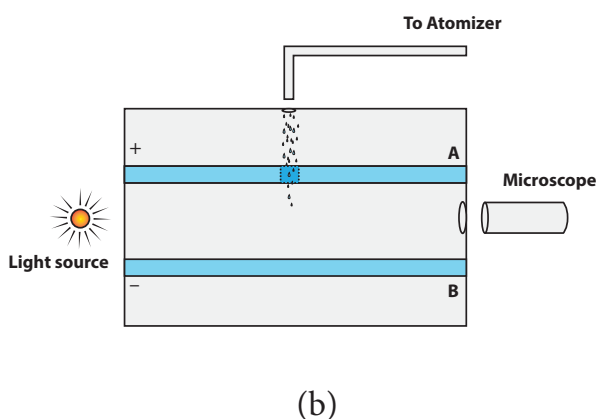
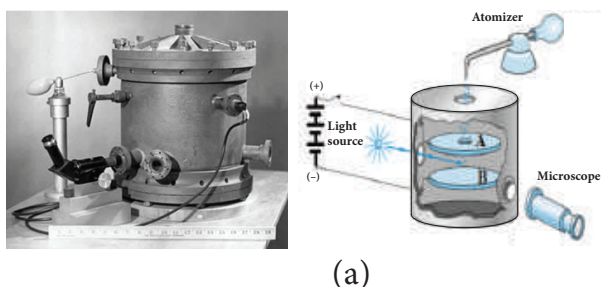

Figure 8.6 Millikan's experiment (a) real picture and schematic picture (b) Side view picture

The experimental arrangement is shown in Figure 8.6 (b). The apparatus consists of two horizontal circular metal plates A and B each with diameter around 20 cm and are separated by a small distance 1.5 cm.

These two parallel plates are enclosed in a chamber with glass walls. Further, plates A and B are given a high potential difference around 10 kV such that electric field acts vertically downward. A small hole is made at the centre of the upper plate A and atomizer is kept exactly above the hole to spray the liquid. When a fine droplet of highly viscous liquid (like glycerine) is sprayed using atomizer, it falls freely downward through the hole of the top plate only under the influence of gravity.

Few oil drops in the chamber can acquire electric charge (negative charge) because of friction with air or passage of x-rays in between the parallel plates. Further the chamber is illuminated by light which is passed horizontally and oil drops can be seen clearly using microscope placed perpendicular to the light beam. These drops can move either upwards or downward.

Let m be the mass of the oil drop and q be its charge. Then the forces acting on the droplet are

- gravitational force $F_g = mg$
- electric force $F_e = qE$
- buoyant force F_b
- viscous force F_v

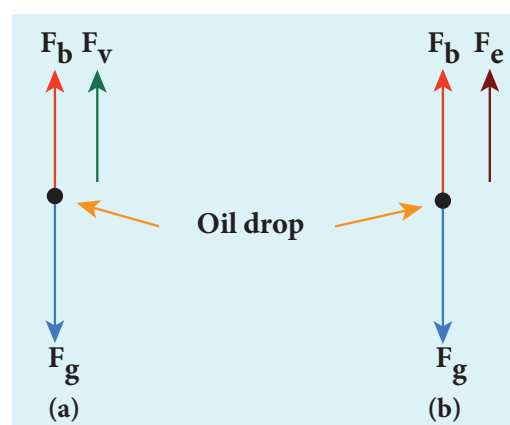

Figure 8.7 Free body diagram of the oil drop – (a) without electric field (b) with electric field

(a) Determination of radius of the droplet

When the electric field is switched off, the oil drop accelerates downwards. Due to the presence of air drag forces, the oil drops easily attain its terminal velocity and moves with constant velocity. This velocity can be carefully measured by noting down the time taken by the oil drop to fall through a predetermined distance. The free body diagram of the oil drop is shown in Figure 8.7 (a), we note that viscous force and buoyant force balance the gravitational force.

Let the gravitational force acting on the oil drop (downward) be $F_g = mg$

Let us assume that oil drop to be spherical in shape. Let ρ be the density of the oil drop, and r be the radius of the oil drop, then the mass of the oil drop can be expressed in terms of its density as

$$\rho = \frac{m}{V}$$
$$\Rightarrow m = \rho \left(\frac{4}{3} \pi r^3 \right) \quad \left(\because \text{volume of the sphere, } V = \frac{4}{3} \pi r^3 \right)$$

The gravitational force can be written in terms of density as

$$F_g = mg \Rightarrow F_g = \rho \left(\frac{4}{3} \pi r^3 \right) g$$

Let σ be the density of the air, the upthrust force experienced by the oil drop due to displaced air is

$$F_b = \sigma \left(\frac{4}{3} \pi r^3 \right) g$$

Once the oil drop attains a terminal velocity v , the net downward force acting on the oil drop is equal to the viscous force acting opposite to the direction of motion of the oil drop. From Stokes law, the viscous force on the oil drop is

$$F_v = 6\pi r v \eta$$

From the free body diagram as shown in Figure 8.7 (a), the force balancing equation is

$$F_g = F_b + F_v$$
$$\rho \left(\frac{4}{3} \pi r^3 \right) g = \sigma \left(\frac{4}{3} \pi r^3 \right) g + 6\pi r v \eta$$
$$\frac{4}{3} \pi r^3 (\rho - \sigma) g = 6\pi r v \eta$$
$$\frac{2}{3} \pi r^3 (\rho - \sigma) g = 3\pi r v \eta$$

$$r = \left[\frac{9\eta v}{2(\rho - \sigma)g} \right]^{\frac{1}{2}} \quad (8.11)$$

Thus, equation (8.11) gives the radius of the oil drop.

(b) Determination of electric charge

When the electric field is switched on, charged oil drops experience an upward electric force (qE). Among many drops, one particular drop can be chosen in the field of view of microscope and strength of the electric field is adjusted to make that particular drop to be stationary. Under these circumstances, there will be no viscous force acting on the oil drop. Then, from the free body diagram shown Figure 8.7 (b), the net force acting on the oil droplet is

$$F_e + F_b = F_g$$
$$\Rightarrow qE + \frac{4}{3} \pi r^3 \sigma g = \frac{4}{3} \pi r^3 \rho g$$
$$\Rightarrow qE = \frac{4}{3} \pi r^3 (\rho - \sigma) g$$

$$\Rightarrow q = \frac{4}{3E} \pi r^3 (\rho - \sigma) g \quad (8.12)$$

Substituting equation (8.11) in equation (8.12), we get

$$q = \frac{18\pi}{E} \left(\frac{\eta^3 v^3}{2(\rho - \sigma)g} \right)^{\frac{1}{2}}$$

Millikan repeated this experiment several times and computed the charges on oil drops. He found that the charge of any oil drop can be written as integral multiple of a basic value, -1.6×10^{-19} C, which is nothing but the charge of an electron.

8.3

ATOM MODELS

Introduction

Around 400 B.C, Greek philosophers Leucippus and Democretus proposed the concept of atom, 'Every object on continued subdivision ultimately yields atoms'. Later, many physicists and chemists tried to understand the nature with the idea of atoms. Many theories were proposed to explain the properties (physical and chemical) of bulk materials on the basis of atomic model.

For instance, J. J. Thomson proposed a theoretical atom model which is based on static distribution of electric charges. Since this model fails to explain the stability of atom, one of his students E. Rutherford proposed the first dynamic model of an atom. Rutherford gave atom model which is based on results of an experiment done by his students (Geiger and Marsden). But this model also failed to explain the stability of the atom.

Later, Niels Bohr who is also a student of Rutherford proposed an atomic model for hydrogen atom which is more successful than other two models. Niels Bohr atom model could explain the stability of the atom and also the origin of line spectrum. There are other atom models, such as Sommerfeld's atom model and atom model from wave mechanics (quantum mechanics). But we will restrict ourselves only to very simple (mathematically simple) atom model in this section.

8.3.1 J. J. Thomson's Model (Water melon model)

In this model, the atoms are visualized as homogeneous spheres which contain uniform distribution of positively charged particles (Figure 8.8 (a)). The negatively charged particles known as electrons are embedded in it like seeds in water melon as shown in Figure 8.8 (b).

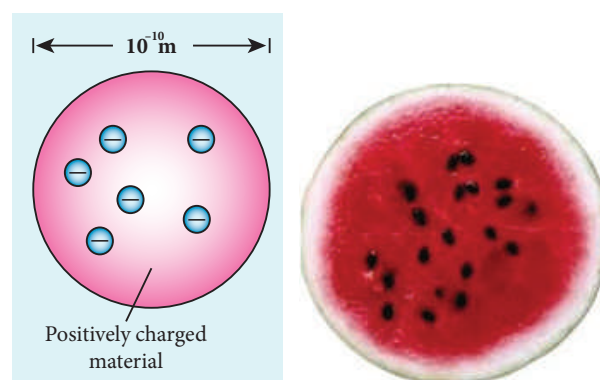

Figure 8.8 (a) Atom (b) Water melon

The atoms are electrically neutral, this implies that the total positive charge in an atom is equal to the total negative charge. According to this model, all the charges are assumed to be at rest. But from classical electrodynamics, no stable equilibrium points exist in electrostatic configuration (this is known as Earnshaw's theorem) and hence such an atom cannot be stable. Further, it fails to explain the origin of spectral lines observed in the spectrum of hydrogen atom and other atoms.

8.3.2 Rutherford's model

In 1911, Geiger and Marsden did a remarkable experiment based on the advice of their teacher Rutherford, which is known as scattering of alpha particles by gold foil.

The experimental arrangement is shown in Figure 8.9. A source of alpha particles (radioactive material, example polonium) is

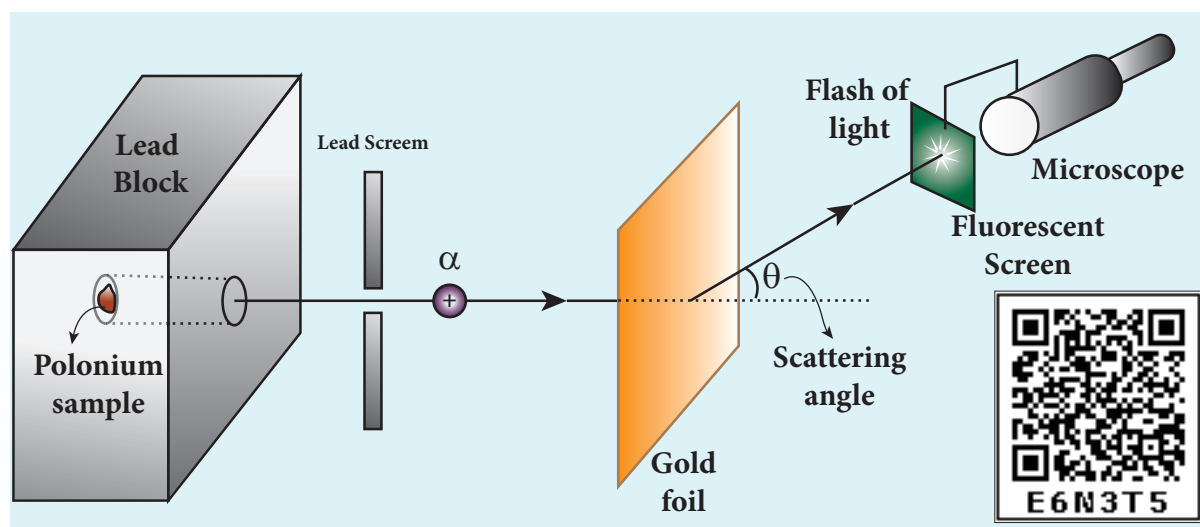

Figure 8.9 Schematic diagram for scattering of alpha particles experiment by Rutherford

kept inside a thick lead box with a fine hole as seen in Figure 8.9. The alpha particles coming through the fine hole of lead box pass through another fine hole made on the lead screen. These particles are now allowed to fall on a thin gold foil and it is observed that the alpha particles passing through gold foil are scattered through different angles. A movable screen (from 0° to 180°) which is made up of zinc sulphide (ZnS) is kept on the other side of the gold foil to collect the alpha particles. Whenever alpha particles strike the screen, a flash of light is observed which can be seen through a microscope.

Rutherford proposed an atom model based on the results of alpha scattering

experiment. In this experiment, alpha particles (positively charged particles) are allowed to fall on the atoms of a metallic gold foil. The results of this experiment are given below and are shown in Figure 8.10, Rutherford expected the nuclear model to be as seen in Figure 8.10 (a) but the experiment showed the model as in Figure 8.10 (b).

- Most of the alpha particles are undeflected through the gold foil and went straight.
- Some of the alpha particles are deflected through a small angle.
- A few alpha particles (one in thousand) are deflected through the angle more than 90°

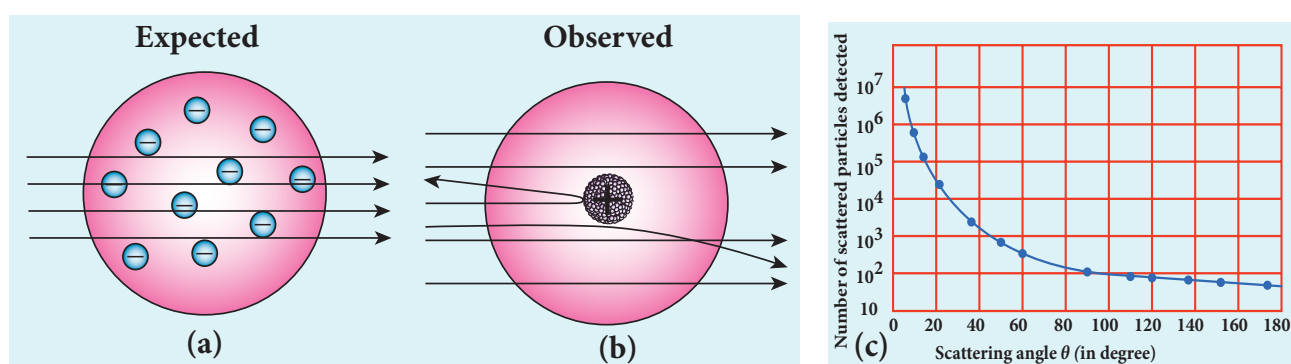

Figure 8.10 In alpha scattering experiment – (a) Rutherford expected (b) experiment result (c) The variation of alpha particles scattered $N(\theta)$ with scattering angle θ

- (d) Very few alpha particles returned back (back scattered) –that is, deflected back by 180°

In Figure 8.10 (c), the dotted points are the alpha scattering experiment data points obtained by Geiger and Marsden and the solid curve is the prediction from Rutherford's nuclear model. It is observed that the Rutherford's nuclear model is in good agreement with the experimental data.

Conclusion made by Rutherford based on the above observation

From the experimental observations, Rutherford proposed that an atom has a lot of empty space and contains a tiny matter known as nucleus whose size is of the order of 10^{-14}m . The nucleus is positively charged and most of the mass of the atom is concentrated in nucleus. The nucleus is surrounded by negatively charged electrons. Since static charge distribution cannot be in a stable equilibrium, he suggested that the electrons are not at rest and they revolve around the nucleus in circular orbits like planets revolving around the sun.

(a) Distance of closest approach

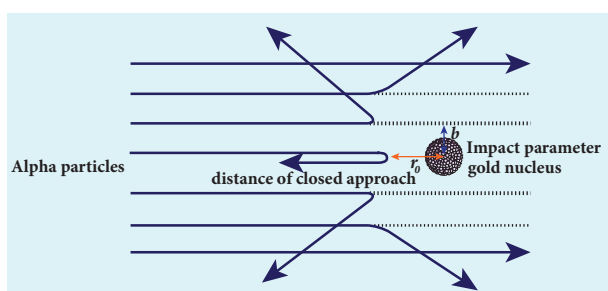

Figure 8.11 Distance of closest approach and impact parameter

When an alpha particle moves straight towards the nucleus, it reaches a point where it comes to rest momentarily and returns back as shown in Figure 8.11. **The minimum distance between the centre**

of the nucleus and the alpha particle just before it gets reflected back through 180° is defined as the distance of closest approach r_0 (also known as contact distance). At this distance, all the kinetic energy of the alpha particle will be converted into electrostatic potential energy (Refer unit 1, volume 1 of +2 physics text book).

$$\frac{1}{2} m v_0^2 = \frac{1}{4\pi\epsilon_0} \frac{(2e)(Ze)}{r_0}$$

$$\Rightarrow r_0 = \frac{1}{4\pi\epsilon_0} \frac{2Ze^2}{\left(\frac{1}{2} m v_0^2\right)} = \frac{1}{4\pi\epsilon_0} \frac{2Ze^2}{E_k}$$

where E_k is the kinetic energy of the alpha particle. This is used to estimate the size of the nucleus but size of the nucleus is always lesser than the distance of closest approach. Further, Rutherford calculated the radius of the nucleus for different nuclei and found that it ranges from 10^{-14} m to 10^{-15} m .

(b) Impact parameter

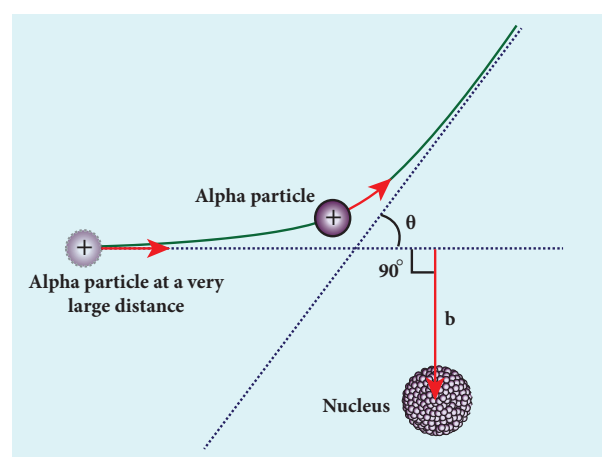

Figure 8.12 Impact parameter

The impact parameter (b) (see Figure 8.12) is defined as the perpendicular distance between the centre of the gold nucleus and the direction of velocity vector of alpha particle when it is at a large distance. The

relation between impact parameter and scattering angle can be shown as

$$b \propto \cot\left(\frac{\theta}{2}\right) \Rightarrow b = K \cot\left(\frac{\theta}{2}\right) \quad (8.13)$$

where $K = \frac{1}{4\pi\epsilon_0} \frac{2Ze^2}{mv_0^2}$ and θ is called scattering angle. Equation (8.13) implies that when impact parameter increases, the scattering angle decreases. Smaller the impact parameter, larger will be the deflection of alpha particles.

Drawbacks of Rutherford model

Rutherford atom model helps in the calculation of the diameter of the nucleus and also the size of the atom but has the following limitations:

(a) This model fails to explain the distribution of electrons around the nucleus and also the stability of the atom.

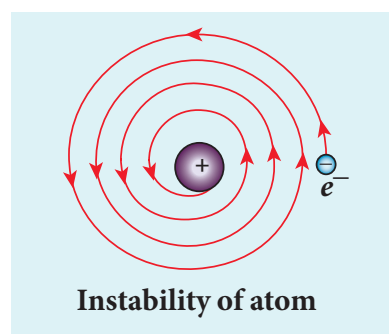

Figure 8.13 Spiral in motion of an electron around the nucleus

According to classical electrodynamics, any accelerated charge emits electromagnetic radiations. Due to emission of radiations, it loses its energy. Hence, it can no longer sustain the circular motion. The radius of the orbit, therefore, becomes smaller and smaller (undergoes spiral motion) as shown in Figure 8.13 and finally the electron should fall into the nucleus and the atoms should disintegrate. But this does not happen.

Hence, Rutherford model could not account for the stability of atoms.

(b) According to this model, emission of radiation must be continuous and must give continuous emission spectrum but experimentally we observe only line (discrete) emission spectrum for atoms.

8.3.3 Bohr atom model

In order to overcome the limitations of the Rutherford atom model in explaining the stability and also the line spectrum observed for a hydrogen atom (Figure 8.14), Niels Bohr made modifications of Rutherford atom model. He is the first person to give better theoretical model of the structure of an atom to explain the line spectrum of hydrogen atom. The following are the assumptions (postulates) made by Bohr.



Figure 8.14 The line spectrum of hydrogen

Postulates of Bohr atom model:

(a) The electron in an atom moves around nucleus in circular orbits under the influence of Coulomb electrostatic force of attraction. This Coulomb force gives necessary centripetal force for the electron to undergo circular motion.

(b) Electrons in an atom revolve around the nucleus only in certain discrete orbits called stationary orbits where it does not radiate electromagnetic energy. Only those discrete orbits allowed are stable orbits.

The angular momentum of the electron in these stationary orbits are quantized – that is, it can be written as integer or integral

multiple of $\frac{h}{2\pi}$ called as reduced Planck's constant – that is, \hbar (read it as h-bar) and the integer n is called as principal quantum number of the orbit.

$$l = n\hbar \quad \text{where } \hbar = \frac{h}{2\pi}$$

This condition is known as angular momentum quantization condition.

According to quantum mechanics, particles like electrons have dual nature (Refer unit 7, volume 2 of +2 physics text book). The standing wave pattern of the de Broglie wave associated with orbiting electron in a stable orbit is shown in Figure 8.15.

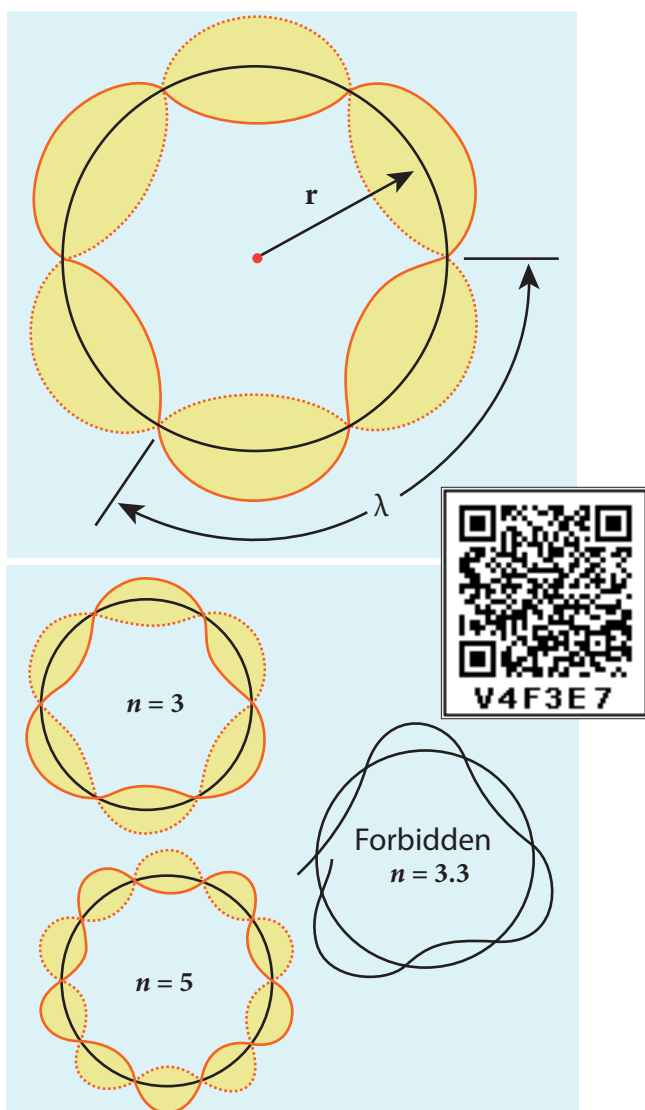

Figure 8.15 Standing wave pattern for electron in a stable orbit

The circumference of an electron's orbit of radius r must be an integral multiple of de Broglie wavelength – that is,

$$2\pi r = n\lambda \quad (8.14)$$

where $n = 1, 2, 3, \dots$

But the de Broglie wavelength (λ) for an electron of mass m moving with velocity v is $\lambda = \frac{h}{mv}$ where h is called Planck's constant.

Thus from equation (8.14),

$$2\pi r = n \left(\frac{h}{mv} \right)$$

$$mv r = n \frac{h}{2\pi}$$

For any particle of mass m undergoing circular motion with radius r and velocity v , the magnitude of angular momentum l is given by

$$l = r(mv)$$

$$mv r = l = n\hbar$$

(c) Energy of orbits are not continuous but discrete. This is called the quantization of energy. An electron can jump from one orbit to another orbit by absorbing or emitting a photon whose energy is equal to the difference in energy (ΔE) between the two orbital levels (Figure 8.16)

$$\Delta E = E_{final} - E_{initial} = h\nu = h \frac{c}{\lambda}$$

where c is the speed of light and λ is the wavelength of the radiation used and ν is the frequency of the radiation. Thus, the frequency of the radiation emitted is related only to change in atom's energy and it does not depend on frequency of electron's orbital motion.

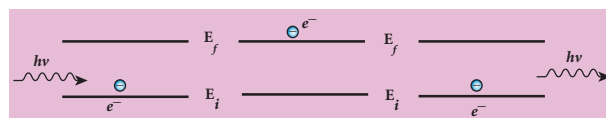

Figure 8.16 Absorption and emission of radiation

EXAMPLE 8.1

The radius of the 5th orbit of hydrogen atom is 13.25 Å. Calculate the wavelength of the electron in the 5th orbit.

Solution:

$$2\pi r = n\lambda$$

$$2 \times 3.14 \times 13.25 \text{ \AA} = 5 \times \lambda$$

$$\therefore \lambda = 16.64 \text{ \AA}$$

EXAMPLE 8.2

Find the (i) angular momentum (ii) velocity of the electron in the 5th orbit of hydrogen atom.

$$(h = 6.6 \times 10^{-34} \text{ Js}, m = 9.1 \times 10^{-31} \text{ kg})$$

Solution

(i) Angular momentum is given by

$$\begin{aligned} l &= n\hbar = \frac{nh}{2\pi} \\ &= \frac{5 \times 6.6 \times 10^{-34}}{2 \times 3.14} = 5.25 \times 10^{-34} \text{ kgm}^2\text{s}^{-1} \end{aligned}$$

(ii) Velocity is given by

$$\begin{aligned} \text{Velocity } v &= \frac{l}{mr} \\ &= \frac{(5.25 \times 10^{-34} \text{ kgm}^2\text{s}^{-1})}{(9.1 \times 10^{-31} \text{ kg})(13.25 \times 10^{-10} \text{ m})} \\ v &= 4.4 \times 10^5 \text{ ms}^{-1} \end{aligned}$$

Radius of the orbit of the electron and velocity of the electron

Consider an atom which contains the nucleus at rest and an electron revolving around the nucleus in a circular orbit of radius r_n as shown in Figure 8.17. Nucleus is made up of protons and neutrons. Since proton is positively charged and neutron is electrically neutral, the charge of a nucleus is purely the total charge of protons.

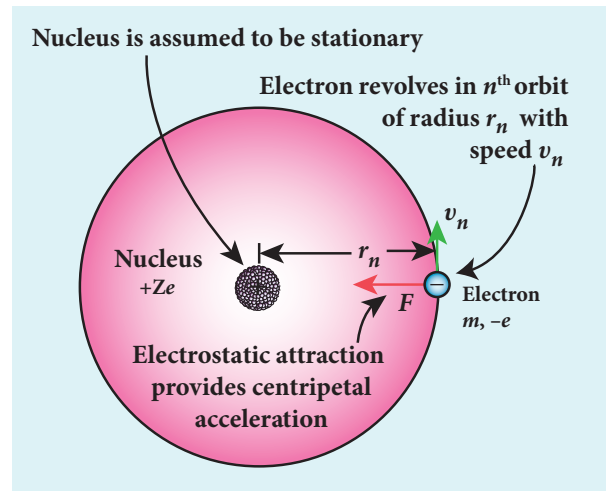

Figure 8.17 Electron revolving around the nucleus

Let Z be the atomic number of the atom, then $+Ze$ is the charge of the nucleus. Let $-e$ be the charge of the electron. From Coulomb's law, the force of attraction between the nucleus and the electron is

$$\begin{aligned} \vec{F}_{\text{Coulomb}} &= \frac{1}{4\pi\epsilon_0} \frac{(+Ze)(-e)}{r_n^2} \hat{r} \\ &= -\frac{1}{4\pi\epsilon_0} \frac{Ze^2}{r_n^2} \hat{r} \end{aligned}$$

This force provides necessary centripetal force

$$\vec{F}_{\text{centripetal}} = \frac{mv_n^2}{r_n} \hat{r}$$

where m be the mass of the electron that moves with a velocity v_n in a circular orbit. Therefore,

$$|\vec{F}_{\text{Coulomb}}| = |\vec{F}_{\text{centripetal}}|$$

$$\frac{1}{4\pi\epsilon_0} \frac{Ze^2}{r_n^2} = \frac{mv_n^2}{r_n}$$

$$r_n = \frac{4\pi\epsilon_0 (mv_n r_n)^2}{Zme^2} \quad (8.15)$$

From Bohr's assumption, the angular momentum quantization condition, $mv_n r_n = l_n = n\hbar$,

$$\therefore r_n = \frac{4\pi\epsilon_0(mv_n r_n)^2}{Zme^2}$$

$$r_n = \frac{4\pi\epsilon_0(n\hbar)^2}{Zme^2} = \frac{4\pi\epsilon_0 n^2 \hbar^2}{Zme^2}$$

$$r_n = \left(\frac{\epsilon_0 \hbar^2}{\pi m e^2} \right) \frac{n^2}{Z} \quad (\because \hbar = \frac{h}{2\pi}) \quad (8.16)$$

where $n \in \mathbb{N}$. Since, ϵ_0 , h , e and π are constants. Therefore, the radius of the orbit becomes

$$r_n = a_0 \frac{n^2}{Z}$$

where $a_0 = \frac{\epsilon_0 \hbar^2}{\pi m e^2} = 0.529 \text{ \AA}$. This is known as Bohr radius which is the smallest radius of the orbit in an atom. Bohr radius is also used as unit of length called Bohr. 1 Bohr = 0.53 \text{ \AA}. For hydrogen atom ($Z = 1$), the radius of n^{th} orbit is

$$r_n = a_0 n^2$$

For $n = 1$ (first orbit or ground state),

$$r_1 = a_0 = 0.529 \text{ \AA}$$

For $n = 2$ (second orbit or first excited state),

$$r_2 = 4a_0 = 2.116 \text{ \AA}$$

For $n = 3$ (third orbit or second excited state),

$$r_3 = 9a_0 = 4.761 \text{ \AA}$$

and so on.

Thus the radius of the orbit from centre increases with n , that is, $r_n \propto n^2$ as shown in Figure 8.18.

Further, Bohr's angular momentum quantization condition leads to

$$mv_n r_n = mv_n a_0 n^2 = n \frac{h}{2\pi}$$

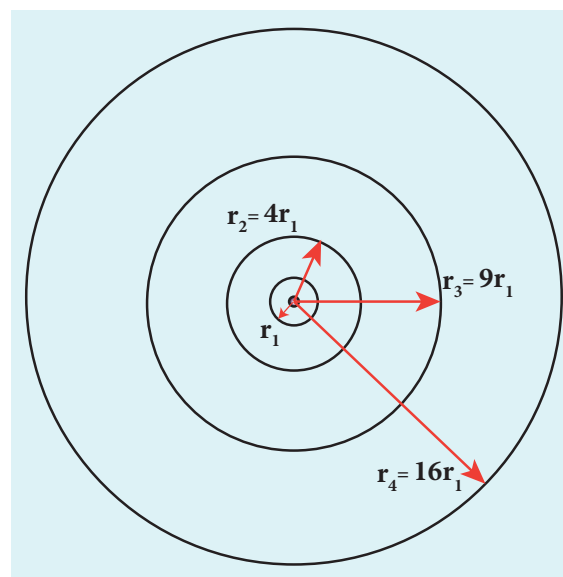

Figure 8.18 Variation of radius of the orbit with principal quantum number

$$v_n = \frac{h}{2\pi m a_0} \frac{Z}{n}$$

$$v_n \propto \frac{1}{n}$$

Note that the velocity of electron decreases as the principal quantum number increases as shown in Figure 8.19. This curve is the rectangular hyperbola. This implies that the velocity of electron in ground state is maximum when compared to excited states.

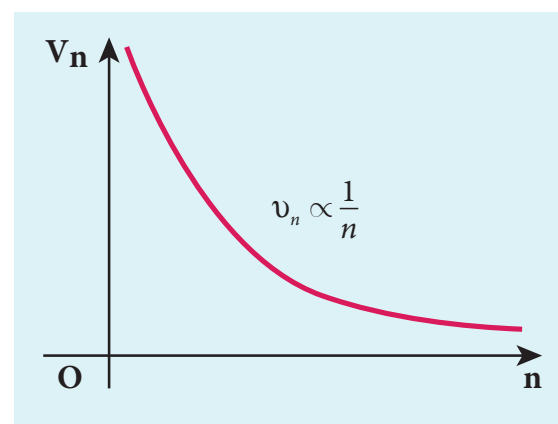

Figure 8.19 Variation of velocity of the electron in the orbit with principal quantum number

The energy of an electron in the n^{th} orbit

Since the electrostatic force is a conservative force, the potential energy for the n^{th} orbit is

$$U_n = \frac{1}{4\pi\epsilon_0} \frac{(+Ze)(-e)}{r_n} = -\frac{1}{4\pi\epsilon_0} \frac{Ze^2}{r_n}$$

$$= -\frac{1}{4\epsilon_0^2} \frac{Z^2 me^4}{h^2 n^2} \left(\because r_n = \frac{\epsilon_0 h^2 n^2}{\pi m e^2 Z} \right)$$

The kinetic energy for the n^{th} orbit is

$$KE_n = \frac{1}{2} m v_n^2 = \frac{me^4}{8\epsilon_0^2 h^2} \frac{Z^2}{n^2}$$

This implies that $U_n = -2 KE_n$. Total energy in the n^{th} orbit is

$$E_n = KE_n + U_n = KE_n - 2KE_n = -KE_n$$

$$E_n = -\frac{me^4}{8\epsilon_0^2 h^2} \frac{Z^2}{n^2}$$

For hydrogen atom ($Z = 1$),

$$E_n = -\frac{me^4}{8\epsilon_0^2 h^2} \frac{1}{n^2} \text{ joule} \quad (8.17)$$

where n stands for principal quantum number. The negative sign in equation (8.17) indicates that the electron is bound to the nucleus.

Substituting the values of mass and charge of an electron (m and e), permittivity of free space ϵ_0 and Planck's constant h and expressing in terms of eV , we get

$$E_n = -13.6 \frac{1}{n^2} eV$$

For the first orbit (ground state), the total energy of electron is $E_1 = -13.6 eV$.

For the second orbit (first excited state), the total energy of electron is $E_2 = -3.4 eV$.

For the third orbit (second excited state), the total energy of electron is $E_3 = -1.51 eV$ and so on.

Notice that the energy of the first excited state is greater than the ground state, second excited state is greater than the first excited state and so on. Thus, the orbit which is closest to the nucleus (r_1) has lowest energy (minimum energy compared with other orbits). So, it is often called ground state energy (lowest energy state). The ground state energy of hydrogen ($-13.6 eV$) is used as a unit of energy called Rydberg ($1 \text{ Rydberg} = -13.6 eV$).

The negative value of this energy is because of the way the zero of the potential energy is defined. When the electron is taken away to an infinite distance (very far distance) from nucleus, both the potential energy and kinetic energy terms vanish and hence the total energy also vanishes.

The energy level diagram along with the shape of the orbits for increasing values of n are shown in Figure 8.20. It shows that the energies of the excited states come closer and closer together when the principal quantum number n takes higher values.

EXAMPLE 8.3

- Show that the ratio of velocity of an electron in the first Bohr orbit to the speed of light c is a dimensionless number.
- Compute the velocity of electrons in ground state, first excited state and second excited state in Bohr atom model.

Solution

- The velocity of an electron in n^{th} orbit is

$$v_n = \frac{h}{2\pi m a_0} \frac{Z}{n}$$

where $a_0 = \frac{\epsilon_0 h^2}{\pi m e^2} = \text{Bohr radius}$. Substituting for a_0 in v_n ,

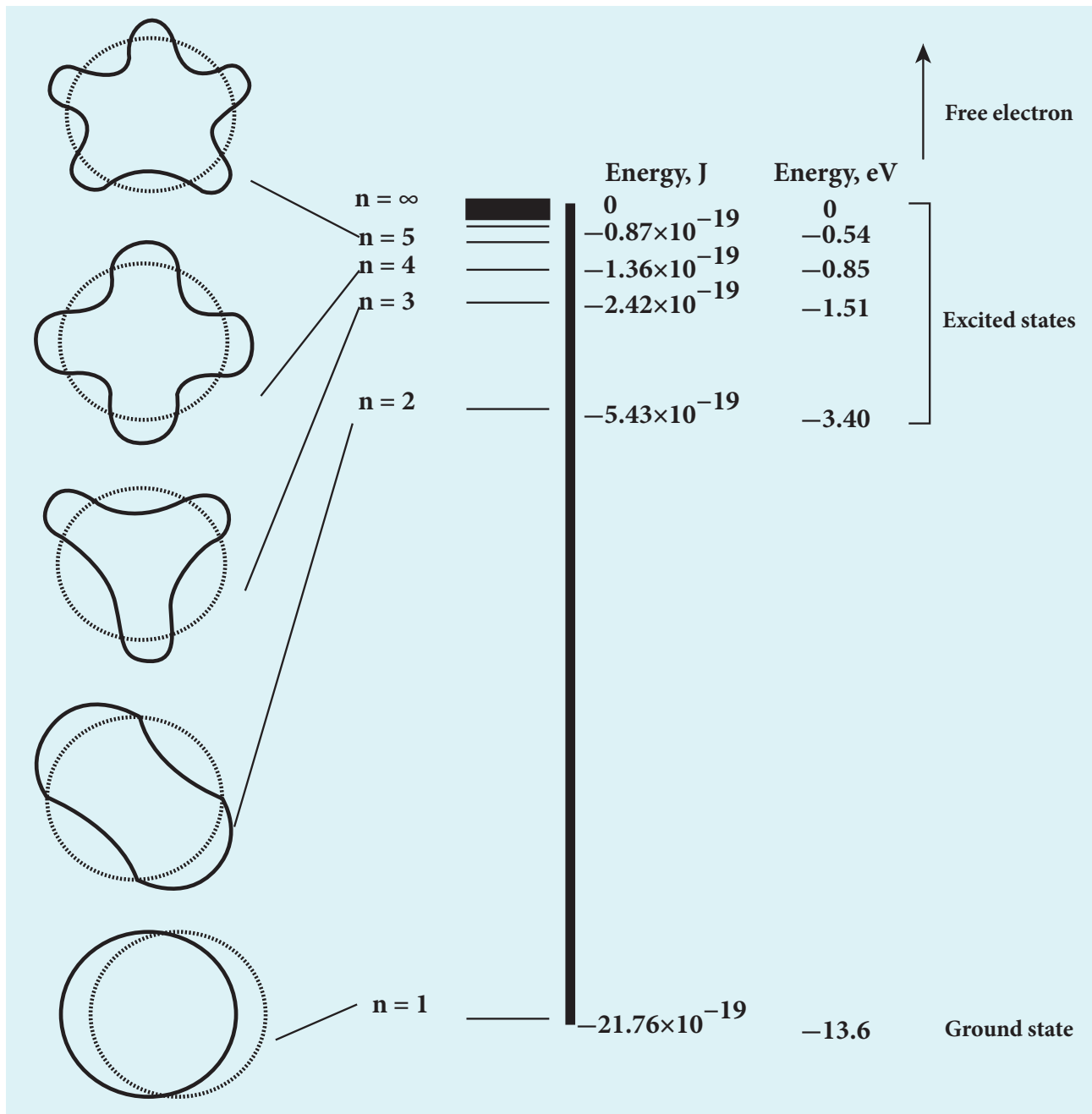

Figure 8.20 Energy levels of a hydrogen atom

$$v_n = \frac{e^2 Z}{2\epsilon_0 h n} = c \left(\frac{e^2}{2\epsilon_0 hc} \right) \frac{Z}{n} = \frac{\alpha c Z}{n}$$

where c is the speed of light in free space or vacuum and its value is $c = 3 \times 10^8 \text{ m s}^{-1}$ and α is called fine structure constant.

For a hydrogen atom, $Z = 1$ and for the first orbit, $n = 1$, the ratio of velocity of electron in first orbit to the speed of light in vacuum or free space is

$$\alpha = \frac{(1.6 \times 10^{-19} \text{ C})^2}{2 \times (8.854 \times 10^{-12} \text{ C}^2 \text{ N}^{-1} \text{ m}^{-2})} \frac{(1.6 \times 10^{-19} \text{ C})^2}{(6.6 \times 10^{-34} \text{ Nms}) \times (3 \times 10^8 \text{ ms}^{-1})}$$

$$\frac{v_1}{c} = \alpha = \frac{e^2}{2\epsilon_0 hc} \approx \frac{1}{136.9} = \frac{1}{137} \text{ which is a dimensionless number}$$





$$\Rightarrow \alpha = \frac{1}{137}$$

(b) Using fine structure constant, the velocity of electron can be written as

$$v_n = \frac{\alpha c Z}{n}$$

For hydrogen atom ($Z = 1$) the velocity of electron in n^{th} orbit is

$$v_n = \frac{c}{137} \frac{1}{n} = (2.19 \times 10^6) \frac{1}{n} \text{ ms}^{-1}$$

For the first orbit (ground state), the velocity of electron is

$$v_1 = 2.19 \times 10^6 \text{ ms}^{-1}$$

For the second orbit (first excited state), the velocity of electron is

$$v_2 = 1.095 \times 10^6 \text{ ms}^{-1}$$

For the third orbit (second excited state), the velocity of electron is

$$v_3 = 0.73 \times 10^6 \text{ ms}^{-1}$$

Here, $v_1 > v_2 > v_3$

EXAMPLE 8.4

The Bohr atom model is derived with the assumption that the nucleus of the atom is stationary and only electrons revolve around the nucleus. Suppose the nucleus is also in motion, then calculate the energy of this new system.

Solution

Let the mass of the electron be m and mass of the nucleus be M . Since there is no external force acting on the system, the centre of mass of hydrogen atom remains at rest. Hence, both nucleus and electron move about the centre of mass as shown in figure.

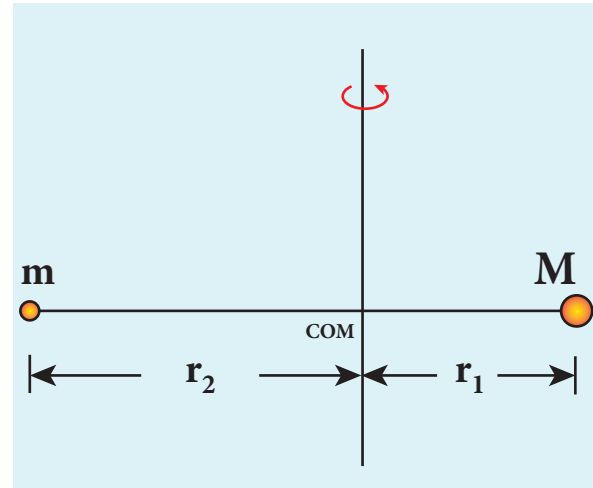

Let V be the velocity of the nuclear motion and v be the velocity of electron motion. Since the total linear momentum of the system is zero,

$$-mv + Mv = 0 \text{ or}$$

$$MV = mv = p$$

$$\vec{p}_e + \vec{p}_n = \vec{0} \text{ or}$$

$$|\vec{p}_e| = |\vec{p}_n| = p$$

Hence, the kinetic energy of the system is

$$KE = \frac{p_n^2}{2M} + \frac{p_e^2}{2m} = \frac{p^2}{2} \left(\frac{1}{M} + \frac{1}{m} \right)$$

Let $\frac{1}{M} + \frac{1}{m} = \frac{1}{\mu_m}$. Here the reduced mass

$$\text{is, } \mu_m = \frac{mM}{M+m}$$

Therefore, the kinetic energy of the system

$$\text{now is } KE = \frac{p^2}{2\mu_m}$$

Since the potential energy of the system is same, the total energy of the hydrogen can be expressed by replacing mass by reduced mass, which is

$$E_n = -\frac{\mu_m e^4}{8\epsilon_0^2 h^2} \frac{1}{n^2}$$

Since the nucleus is very heavy compared to the electron, the reduced mass is closer to the mass of the electron.



Note

In 1931, H.C. Urey and co-workers noticed that in the shorter wavelength region of the hydrogen spectrum lines, faint companion lines are observed. From the isotope displacement effect (isotope shift), the isotope of the same element will have slightly different spectral lines. The presence of these faint lines confirmed the existence of isotopes of hydrogen atom (which is named as Deuterium).

On calculating wavelength or wave number difference between the faint and bright spectral lines, atomic mass of deuterium is measured to be twice that of atomic mass of hydrogen atom. Bohr atom model could not explain this isotopic shift. Thus by considering nuclear motion (although the movement of the nucleus is much smaller, it is observed) into account in the Bohr atom model, the wave number or wavelength difference between hydrogen atom and deuterium is theoretically calculated which perfectly agreed with the spectroscopic measured values.

The difference between hydrogen atom and deuterium is in the number of neutron. Hydrogen atom contains an electron and a proton, whereas deuterium has an electron, a proton and a neutron.

Excitation energy and excitation potential

The energy required to excite an electron from lower energy state to any higher energy state is known as excitation energy.

The excitation energy for an electron from ground state ($n = 1$) to first excited state ($n = 2$) is called first excitation energy, which is

$$E_I = E_2 - E_1 = -3.4 \text{ eV} - (-13.6 \text{ eV}) = 10.2 \text{ eV}$$

Similarly, the excitation energy for an electron from ground state ($n = 1$) to second excited state ($n = 3$) is called second excitation energy, which is

$$E_{II} = E_3 - E_1 = -1.51 \text{ eV} - (-13.6 \text{ eV}) = 12.1 \text{ eV}$$

and so on.

Excitation potential is defined as excitation energy per unit charge.

First excitation potential is,

$$E_I = eV_I \Rightarrow V_I = \frac{1}{e} E_I = 10.2 \text{ volt}$$

Second excitation potential is,

$$E_{II} = eV_{II} \Rightarrow V_{II} = \frac{1}{e} E_{II} = 12.1 \text{ volt}$$

and so on.

Ionization energy and ionization potential

An atom is said to be ionized when an electron is completely removed from the atom – that is, it reaches the state with energy $E_{n \rightarrow \infty}$. **The minimum energy required to remove an electron from an atom in the ground state is known as binding energy or ionization energy.**

$$\begin{aligned} E_{\text{ionization}} &= E_{\infty} - E_1 = 0 - (-13.6 \text{ eV}) \\ &= 13.6 \text{ eV} \end{aligned}$$

When an electron is in n^{th} state of an atom, the energy spent to remove an electron from that state – that is, its ionization energy is

$$\begin{aligned} E_{\text{ionization}} &= E_{\infty} - E_n = 0 - \left(-\frac{13.6}{n^2} Z^2 \text{ eV} \right) \\ &= \frac{13.6}{n^2} Z^2 \text{ eV} \end{aligned}$$

At normal room temperature, the electron in a hydrogen atom ($Z=1$) spends most of its time in the ground state. **The amount of energy spent to remove an electron from the ground state of an atom**

Table 8.1

Physical quantity	Ground state	First excited state	Second excited state
Radius ($r_n \propto n^2$)	0.529 Å	2.116 Å	4.761 Å
Velocity ($v_n \propto n^{-1}$)	$2.19 \times 10^6 \text{ m s}^{-1}$	$1.095 \times 10^6 \text{ m s}^{-1}$	$0.73 \times 10^6 \text{ m s}^{-1}$
Total Energy ($E_n \propto n^{-2}$)	-13.6 eV	-3.4 eV	-1.51 eV

($E = 0$ for $n \rightarrow \infty$) is known as **first ionization energy (13.6 eV)**. Then, the hydrogen atom is said to be in ionized state or simply called as hydrogen ion, denoted by H^+ . If we supply more energy than the ionization energy, the excess energy will be the kinetic energy of the free electron.

Ionization potential is defined as ionization energy per unit charge.

$$V_{\text{ionization}} = \frac{1}{e} E_{\text{ionization}} = \frac{13.6}{n^2} Z^2 \text{ V}$$

Thus, for a hydrogen atom ($Z=1$), the ionization potential is

$$V = \frac{13.6}{n^2} \text{ volt}$$

The radius, velocity and total energy in ground state, first excited state and second excited state is listed in Table 8.1.

EXAMPLE 8.5

Suppose the energy of a hydrogen-like atom is given as $E_n = -\frac{54.4}{n^2} \text{ eV}$ where $n \in \mathbb{N}$. Calculate the following:

- Sketch the energy levels for this atom and compute its atomic number.
- If the atom is in ground state, compute its first excitation potential and also its ionization potential.

(c) When a photon with energy 42 eV and another photon with energy 56 eV are made to collide with this atom, does this atom absorb these photons?

(d) Determine the radius of its first Bohr orbit.

(e) Calculate the kinetic and potential energies in the ground state.

Solutions

(a) Given that

$$E_n = -\frac{54.4}{n^2} \text{ eV}$$

For $n = 1$, the ground state energy $E_1 = -54.4 \text{ eV}$ and for $n = 2$, $E_2 = -13.6 \text{ eV}$. Similarly, $E_3 = -6.04 \text{ eV}$, $E_4 = -3.4 \text{ eV}$ and so on.

For large value of principal quantum number – that is, $n = \infty$, we get $E_\infty = 0 \text{ eV}$.

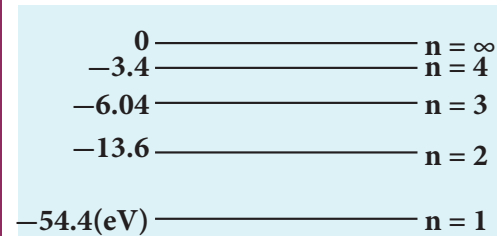

(b) For a hydrogen-like atom, ground state energy is

$$E_1 = -\frac{13.6}{n^2} Z^2 \text{ eV}$$

where Z is the atomic number. Hence, comparing this energy with given energy, we get, $-13.6 Z^2 = -54.4 \Rightarrow Z = \pm 2$. Since, atomic number cannot be negative number, $Z = 2$.

(c) The first excitation energy is

$$E_1 = E_2 - E_1 = -13.6 eV - (-54.4 eV) = 40.8 eV$$

Hence, the first excitation potential is

$$V_1 = \frac{1}{e} E_1 = \frac{(40.8 eV)}{e} = 40.8 \text{ volt}$$

The first ionization energy is

$$E_{\text{ionization}} = E_{\infty} - E_1 = 0 - (-54.4 eV) = 54.4 eV$$

Hence, the first ionization potential is

$$V_{\text{ionization}} = \frac{1}{e} E_{\text{ionization}} = \frac{(54.4 eV)}{e} = 54.4 \text{ volt}$$

(d) Consider two photons to be A and B.

Given that photon A with energy $42 eV$ and photon B with energy $51 eV$

From Bohr assumption, difference in energy levels is equal to photon energy, then atom will absorb energy, otherwise, not.

$$E_2 - E_1 = -13.6 eV - (-54.4 eV) = 40.8 eV \approx 41 eV$$

Similarly,

$$E_3 - E_1 = -6.04 eV - (-54.4 eV) = 48.36 eV$$

$$E_4 - E_1 = -3.4 eV - (-54.4 eV) = 51 eV$$

$$E_3 - E_2 = -6.04 eV - (-13.6 eV) = 7.56 eV$$

and so on.

But note that $E_2 - E_1 \neq 42 eV$, $E_3 - E_1 \neq 42 eV$, $E_4 - E_1 \neq 42 eV$ and $E_3 - E_2 \neq 42 eV$.

For all possibilities, no difference in energy is an integer multiple of photon energy. Hence, photon A is not absorbed by this atom. But for Photon B, $E_4 - E_1 = 51 eV$, which means, Photon B can be absorbed by this atom.

(e) Since total energy is equal to negative of kinetic energy in Bohr atom model, we get

$$KE_n = -E_n = -\left(-\frac{54.4}{n^2} eV\right) = \frac{54.4}{n^2} eV$$

Potential energy is negative of twice the kinetic energy, which means,

$$U_n = -2KE_n = -2\left(\frac{54.4}{n^2} eV\right) = -\frac{108.8}{n^2} eV$$

For a ground state, put $n = 1$

Kinetic energy is $KE_1 = 54.4 eV$ and Potential energy is $U_1 = -108.8 eV$

8.3.4 Atomic spectra

Materials in the solid, liquid and gaseous states emit electromagnetic radiations when they are heated up and these emitted radiations usually belong to continuous spectrum. For example, when white light is examined through a spectrometer, electromagnetic radiations of all wavelengths are observed which is a continuous spectrum.

In early twentieth century, many scientists spent considerable time in understanding the characteristic radiations emitted by the atoms of individual elements exposed to a flame or electrical discharge. When they are viewed

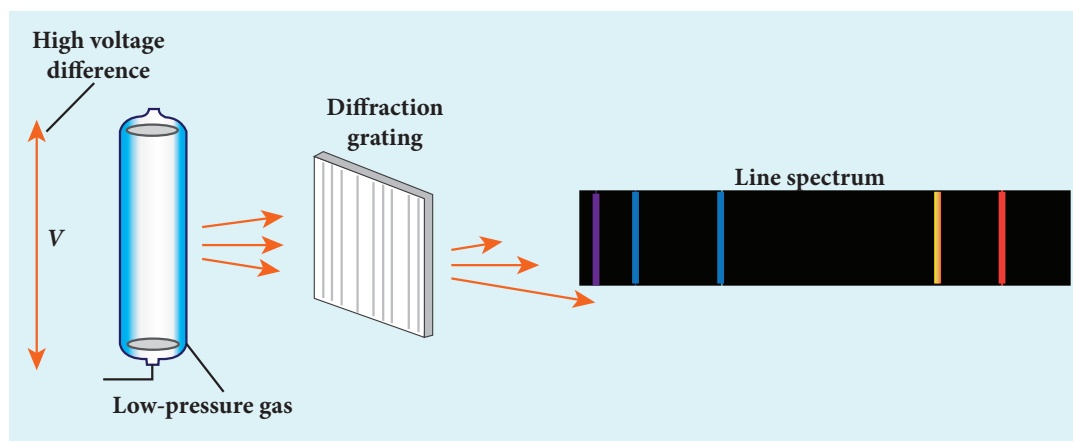

Figure 8.21 Spectrum of an atom

or photographed, instead of a continuous spectrum, the radiation contains a set of discrete lines, each with characteristic wavelength. In other words, the wavelengths of the light obtained are well defined and the positions and intensities are characteristic of the element as shown in Figure 8.21.

This implies that these spectra are unique to each element and can be used to identify the element of the gas (like finger print used to identify a person) – that is, it varies from one gas to another gas. This uniqueness of line spectra of elements made the scientists to determine the composition of stars, sun and also used to identify the unknown compounds.

Hydrogen spectrum

When the hydrogen gas enclosed in a tube is heated up, it emits electromagnetic radiations of certain sharply-defined characteristic wavelength (line spectrum), called hydrogen emission spectrum (Refer unit 5, volume 1 of +2 physics text book). The emission spectra of hydrogen are shown in Figure 8.22(a).

When any gas is heated up, the thermal energy is supplied to excite the electrons. Similarly by passing light on the atoms, electrons can be excited by absorbing

photons. Once the electrons get sufficient energy as given by Bohr's postulate (c), it absorbs energy with particular wavelength (or frequency) and jumps from its stationary state (original state) to higher energy state. Those wavelengths (or frequencies) for which the colours are not observed are seen as dark lines in the absorption spectrum as shown in Figure 8.22 (b).

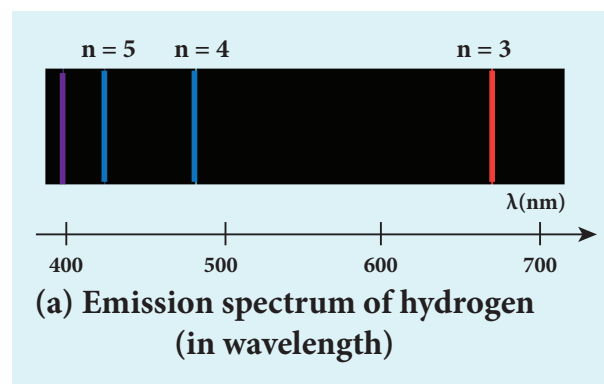

(a) Emission spectrum of hydrogen (in wavelength)

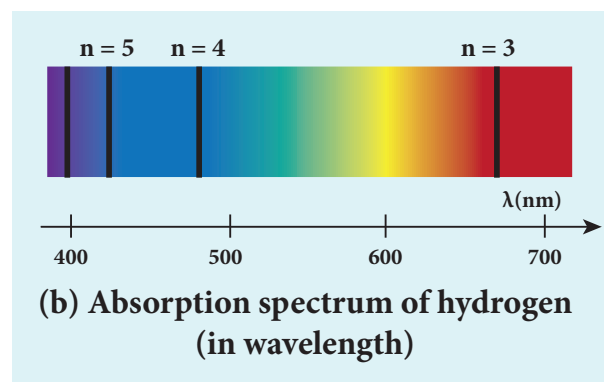

(b) Absorption spectrum of hydrogen (in wavelength)

Figure 8.22 Hydrogen spectrum (a) emission (b) absorption

Since electrons in excited states have very small life time, these electrons jump back to ground state through spontaneous emission in a short duration of time (approximately 10^{-8} s) by emitting the radiation with same wavelength (or frequency) corresponding to the colours it absorbed (Figure 8.22 (a)). This is called emission spectroscopy.

The wavelengths of these lines can be calculated with great precision. Further, the emitted radiation contains wavelengths both lesser and greater than the visible spectrum.

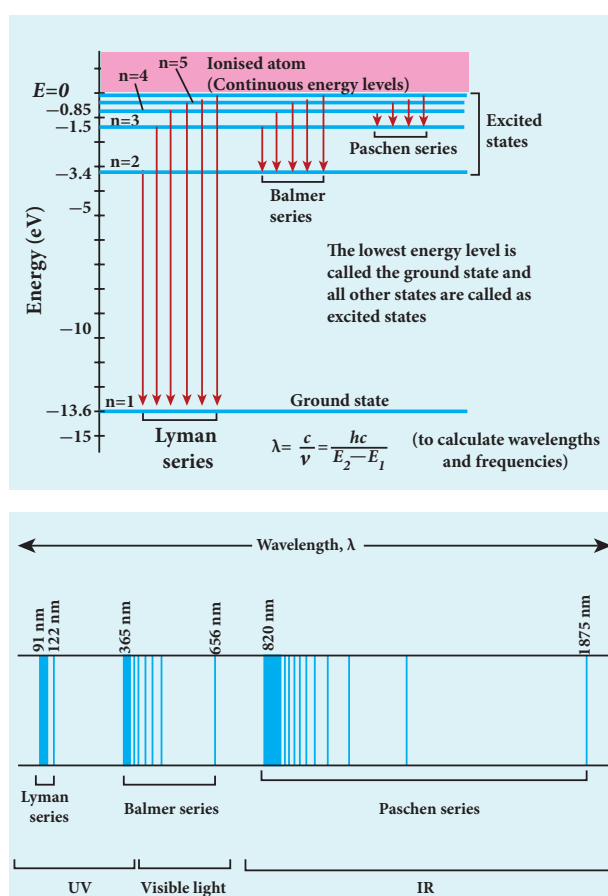

Figure 8.23 Spectral series – Lyman, Balmer, Paschen series

Notice that the spectral lines of hydrogen as shown in Figure 8.23 are grouped in separate series. In each series, the distance of separation between the consecutive wavelengths decreases from higher wavelength to the lower wavelength, and also wavelength in each series approach a limiting value known as the series

limit. These series are named as Lyman series, Balmer series, Paschen series, Brackett series, Pfund series, etc. The wavelengths of these spectral lines perfectly agree with the equation derived from Bohr atom model.

$$\frac{1}{\lambda} = R \left(\frac{1}{n^2} - \frac{1}{m^2} \right) = \bar{\nu} \quad (8.18)$$

where $\bar{\nu}$ is known as wave number which is inverse of wavelength, R is known as Rydberg constant whose value is $1.09737 \times 10^7 \text{ m}^{-1}$ and m and n are positive integers such that $m > n$. The various spectral series are discussed below:

(a) Lyman series

Put $n = 1$ and $m = 2, 3, 4, \dots$ in equation (8.18). The wave number or wavelength of spectral lines of Lyman series which lies in ultra-violet region is

$$\bar{\nu} = \frac{1}{\lambda} = R \left(\frac{1}{1^2} - \frac{1}{m^2} \right)$$

(b) Balmer series

Put $n = 2$ and $m = 3, 4, 5, \dots$ in equation (8.18). The wave number or wavelength of spectral lines of Balmer series which lies in visible region is

$$\bar{\nu} = \frac{1}{\lambda} = R \left(\frac{1}{2^2} - \frac{1}{m^2} \right)$$

(c) Paschen series

Put $n = 3$ and $m = 4, 5, 6, \dots$ in equation (8.18). The wave number or wavelength of spectral lines of Paschen series which lies in infra-red region (near IR) is

$$\bar{\nu} = \frac{1}{\lambda} = R \left(\frac{1}{3^2} - \frac{1}{m^2} \right)$$

(d) Brackett series

Put $n = 4$ and $m = 5, 6, 7, \dots$ in equation (8.18). The wave number or wavelength of

spectral lines of Brackett series which lies in infra-red region (middle IR) is

$$\bar{\nu} = \frac{1}{\lambda} = R \left(\frac{1}{4^2} - \frac{1}{m^2} \right)$$

(e) Pfund series

Put $n = 5$ and $m = 6, 7, 8, \dots$ in equation (8.18). The wave number or wavelength of spectral lines of Pfund series which lies in infra-red region (far IR) is

$$\bar{\nu} = \frac{1}{\lambda} = R \left(\frac{1}{5^2} - \frac{1}{m^2} \right)$$

Different spectral series are listed in Table 8.2.

n	m	Series Name	Region
1	2,3,4.....	Lyman	Ultraviolet
2	3,4,5.....	Balmer	Visible
3	4,5,6.....	Paschen	Infrared
4	5,6,7.....	Brackett	Infrared
5	6,7,8.....	Pfund	Infrared

Limitations of Bohr atom model

The following are the drawbacks of Bohr atom model

- (a) Bohr atom model is valid only for hydrogen atom or hydrogen like-atoms but not for complex atoms.
- (b) When the spectral lines are closely examined, individual lines of hydrogen spectrum is accompanied by a number of faint lines. These are often called **fine structure**. This is not explained by Bohr atom model.
- (c) Bohr atom model fails to explain the intensity variations in the spectral lines.
- (d) The distribution of electrons in atoms is not completely explained by Bohr atom model.

8.4

NUCLEI

Introduction

In the previous section, we have discussed various preliminary atom models, Rutherford's alpha particle scattering experiment and Bohr atom model. These played a vital role to understand the structure of the atom and the nucleus. In this section, the structure and the properties of the nucleus, and its classifications are discussed.

8.4.1 Composition of nucleus

Atoms have a nucleus surrounded by electrons. The nucleus contains protons and neutrons. The neutrons are electrically neutral ($q=0$) and the protons have positive charge ($q=+e$) equal in magnitude of the charge of the electron ($q=-e$). **The number of protons in the nucleus is called the atomic number** and it is denoted by Z . The number of neutrons in the nucleus is called neutron number (N). **The total number of neutrons and protons in the nucleus is called the mass number** and it is denoted by A . Hence, $A = Z+N$.

The two constituents of nucleus namely neutrons and protons, are collectively called nucleons. The mass of a proton is 1.6726×10^{-27} kg which is roughly 1836 times the mass of the electron. The mass of a neutron is slightly greater than the mass of the proton and it is equal to 1.6749×10^{-27} kg.

To specify the nucleus of any element, we use the following general notation



where X is the chemical symbol of the element, A is the mass number and Z is the atomic number. For example,

the nitrogen nucleus is represented by ${}^{15}_7N$. It implies that nitrogen contains 15 nucleons of which 7 are protons ($Z=7$) and 8 are neutrons ($N=A-Z=8$). Note that once the element is specified, the value of Z is known and subscript Z is sometimes omitted. For example, nitrogen nucleus is simply denoted as ${}^{15}N$ and we call it as 'nitrogen fifteen'.

Since the nucleus is made up of positively charged protons and electrically neutral neutrons, the overall charge of the nucleus is positive and it has the value of $+Ze$. But the atom is electrically neutral which implies that the number of electrons in the atom is equal to the number of protons in the nucleus.

8.4.2 Isotopes, isobars, and isotones

Isotopes:

In nature, there are atoms of a particular element whose nuclei have same number of protons but different number of neutrons. These kinds of atoms are called isotopes. In other words, **isotopes are atoms of the same element having same atomic number Z , but different mass number A** . For example, hydrogen has three isotopes and they are represented as 1_1H (hydrogen), 2_1H (deuterium), and 3_1H (tritium). Note that all the three nuclei have one proton and, hydrogen has no neutron, deuterium has 1 neutron and tritium has 2 neutrons.

The number of isotopes for the particular element and their relative abundances (percentage) vary with each element. For example, carbon has four main isotopes: ${}^{11}_6C$, ${}^{12}_6C$, ${}^{13}_6C$ and ${}^{14}_6C$. But in nature, the percentage of ${}^{12}_6C$ is approximately 98.9%, that of ${}^{13}_6C$ is 1.1% and that of ${}^{14}_6C$ is 0.0001%. The other carbon isotope ${}^{11}_6C$, do not occur naturally and it can be produced

only in nuclear reactions in the laboratory or by cosmic rays.

The chemical properties of any atom are determined only by electrons, the isotopes of any element have same electronic structure and same chemical properties. So the isotopes of the same element are placed in the same location in the periodic table.

Isobars:

Isobars are the atoms of different elements having the same mass number A , but different atomic number Z . In other words, isobars are the atoms of different chemical element which has same number of nucleon. For example ${}^{40}_{16}S$, ${}^{40}_{17}Cl$, ${}^{40}_{18}Ar$, ${}^{40}_{19}K$ and ${}^{40}_{20}Ca$ are isobars having same mass number 40 and different atomic number. Unlike isotopes, isobars are chemically different elements. They have different physical and chemical properties.

Isotones:

Isotones are the atoms of different elements having same number of neutrons. ${}^{12}_5B$ and ${}^{13}_6C$ are examples of isotones which 7 neutrons.

8.4.3 Atomic and nuclear masses

The mass of nuclei is very small when it expressed in SI units (about 10^{-25} kg or less). Therefore, it is more convenient to express it in terms of another unit namely, the *atomic mass unit* (u). **One atomic mass unit (u) is defined as the $1/12^{\text{th}}$ of the mass of the isotope of carbon ${}^{12}_6C$, the most abundant naturally occurring isotope of carbon.**

In other words

$$1 u = \frac{\text{mass of } {}^{12}_6C \text{ atom}}{12} = \frac{1.9926 \times 10^{-26}}{12} \\ = 1.660 \times 10^{-27} \text{ kg}$$

In terms of this atomic mass unit, the mass of the neutron = 1.008665 u , the mass of the proton = 1.007276 u , the mass of the hydrogen atom = 1.007825 u and the mass of ${}^{12}_6\text{C} = 12u$. Note that usually mass specified is the mass of the atoms, not mass of the nucleus. To get the nuclear mass of particular nucleus, the mass of electrons has to be subtracted from the corresponding atomic mass. Experimentally the atomic mass is determined by the instrument called Bainbridge mass spectrometer. If we determine the atomic mass of the element without considering the effect of its isotopes, we get the mass averaged over different isotopes weighted by their abundances.

EXAMPLE 8.6

Calculate the average atomic mass of chlorine if no distinction is made between its different isotopes?

Solution

The element chlorine is a mixture of 75.77% of ${}^{35}_{17}\text{Cl}$ and 24.23% of ${}^{37}_{17}\text{Cl}$. So the average atomic mass will be

$$\frac{75.77}{100} \times 34.96885u + \frac{24.23}{100} \times 36.96593u = 35.453u$$

In fact, the chemist uses the average atomic mass or simply called chemical atomic weight (35.453 u for chlorine) of an element. So it must be remembered that the atomic mass which is mentioned in the periodic table is basically averaged atomic mass.

8.4.4 Size and density of the nucleus

The alpha particle scattering experiment and many other measurements using

different methods have been carried out on the nuclei of various atoms. The nuclei are found to be approximately spherical in shape. It is experimentally found that radius of nuclei for $Z > 10$, satisfies the following empirical formula

$$R = R_0 A^{\frac{1}{3}} \quad (8.19)$$

Here A is the mass number of the nucleus and the constant $R_0 = 1.2 \text{ F}$, where $1 \text{ F} = 1 \times 10^{-15} \text{ m}$. The unit fermi (F) is named after Enrico Fermi.

EXAMPLE 8.7

Calculate the radius of ${}^{197}_{79}\text{Au}$ nucleus.

Solution

According to the equation (8.19),

$$R = 1.2 \times 10^{-15} \times (197)^{\frac{1}{3}} = 6.97 \times 10^{-15} \text{ m}$$

$$\text{Or } R = 6.97 \text{ F}$$

EXAMPLE 8.8

Calculate the density of the nucleus with mass number A .

Solution

From equation (8.19), the radius of the nuclei satisfy the equation $= R_0 A^{\frac{1}{3}}$. Then the volume of the nucleus

$$V = \frac{4}{3} \pi R^3 = \frac{4}{3} \pi R_0^3 A$$

By ignoring the mass difference between the proton and neutron, the total mass of the nucleus having mass number A is equal to $A \cdot m$ where m is mass of the proton and is equal to $1.6726 \times 10^{-27} \text{ kg}$.

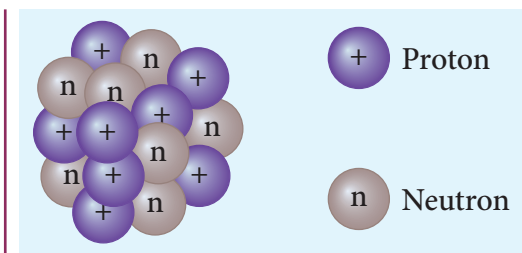

Nuclear density

$$\rho = \frac{\text{mass of the nuclei}}{\text{Volume of the nuclei}} = \frac{A \cdot m}{\frac{4}{3} \pi R_0^3 A} = \frac{m}{\frac{4}{3} \pi R_0^3}$$

The above expression shows that the nuclear density is independent of the mass number A . In other words, all the nuclei ($Z > 10$) have the same density and it is an important characteristics of the nuclei.

We can calculate the numerical value of this density by substituting the corresponding values.

$$\rho = \frac{1.67 \times 10^{-27}}{\frac{4}{3} \pi \times (1.2 \times 10^{-15})^3} = 2.3 \times 10^{17} \text{ kg m}^{-3}.$$

It implies that nucleons are extremely tightly packed in the nucleus and compare this density with the density of water which is 10^3 kg m^{-3} .



A single teaspoon of nuclear matter would weigh about trillion tons.

8.4.5 Mass defect and binding energy

It is experimentally found out that the mass of any nucleus is always less than the sum of the mass of its individual constituents. For example, consider the carbon-12 nucleus which is made up of 6 protons and 6 neutrons.
 Mass of 6 neutrons = $6 \times 1.00866 \text{ u} = 6.05196 \text{ u}$
 Mass of 6 protons = $6 \times 1.00727 \text{ u} = 6.04362 \text{ u}$

Mass of 6 electrons = $6 \times 0.00055 \text{ u} = 0.0033 \text{ u}$

The expected mass of carbon-12 nucleus = $6.05196 \text{ u} + 6.04362 \text{ u} = 12.09558 \text{ u}$

But using mass spectroscopy, the atomic mass of carbon-12 atom is found to be 12 u . So if we subtract the mass of 6 electrons (0.0033 u) from 12 u , we get the carbon-12 nuclear mass which is equal to 11.9967 u . Note that the experimental mass of carbon-12 nucleus is less than the total mass of its individual constituents by $\Delta m = 0.09888 \text{ u}$. This difference in mass Δm is called mass defect. In general, if M , m_p , and m_n are mass of the nucleus (${}^A_Z X$), the mass of a proton and the mass of a neutron respectively, then the mass defect is given by

$$\Delta m = (Zm_p + Nm_n) - M \quad (8.20)$$

Where has this mass disappeared? The answer was provided by Albert Einstein with the help of famous mass-energy relation ($E = mc^2$). According to this relation, the mass can be converted into energy and energy can be converted into mass. In the case of the carbon-12 nucleus, when 6 protons and 6 neutrons combine to form carbon-12 nucleus, mass equal to mass defect disappears and the corresponding energy is released. This is called the binding energy of the nucleus (BE) and is equal to $(\Delta m)c^2$. In fact, to separate the carbon-12 nucleus into individual constituents, we must supply the energy equal to binding energy of the nucleus.

We can write the equation (8.20) in terms of binding energy

$$BE = (Zm_p + Nm_n - M)c^2 \quad (8.21)$$

It is always convenient to work with the mass of the atom than the mass of the

nucleus. Hence by adding and subtracting the mass of the Z electrons, we get

$$BE = (Zm_p + Zm_e + Nm_n - M - Zm_e)c^2 \quad (8.22)$$

$$BE = [Z(m_p + m_e) + Nm_n - M - Zm_e]c^2$$

where $m_p + m_e = m_H$ (mass of hydrogen atom)

$$BE = [Zm_H + Nm_n - (M + Zm_e)]c^2 \quad (8.23)$$

Here $M + Zm_e = M_A$ where M_A is the mass of the atom of an element A_ZX .

Finally, the binding energy in terms of the atomic masses is given by

$$BE = [Zm_H + Nm_n - M_A]c^2 \quad (8.24)$$



Note Using Einstein's mass-energy equivalence, the energy equivalent of one atomic mass unit $1u = 1.66 \times 10^{-27} \times (3 \times 10^8)^2 = 14.94 \times 10^{-11} J \approx 931 MeV$

EXAMPLE 8.9

Compute the binding energy of 4_2He nucleus using the following data: Atomic mass of Helium atom, $M_A(He) = 4.00260u$ and that of hydrogen atom, $m_H = 1.00785u$.

Solution:

$$\text{Binding energy } BE = [Zm_H + Nm_n - M_A]c^2$$

For helium nucleus, $Z = 2, N = A - Z = 4 - 2 = 2$

Mass defect

$$\Delta m = [(2 \times 1.00785u) + (2 \times 1.008665u) - 4.00260u] \Delta m = 0.03038u$$

$$B.E = 0.03038u \times c^2$$

$$B.E = 0.03038 \times 931 MeV = 28 MeV$$

$$[\because 1uc^2 = 931 MeV]$$

The binding energy of the 4_2He nucleus is 28 MeV.

8.4.6 Binding energy curve

In the previous section, the origin of the binding energy is discussed. Now we can find the average binding energy per nucleon \overline{BE} . It is given by

$$\overline{BE} = \frac{[Zm_H + Nm_n - M_A]c^2}{A} \quad (8.25)$$

The average binding energy per nucleon is the energy required to separate single nucleon from the particular nucleus. \overline{BE} is plotted against A of all known nuclei. It gives a curve as seen in Figure 8.24.

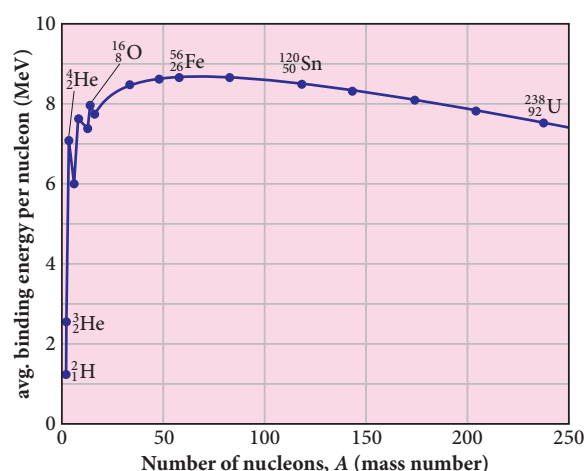

Figure 8.24 Avg. binding energy of the nucleons

Important inferences from of the average binding energy curve:

- (1) The value of \overline{BE} rises as the mass number increases until it reaches a maximum value of 8.8 MeV for $A = 56$ (iron) and then it slowly decreases.
- (2) The average binding energy per nucleon is about 8.5 MeV for nuclei having mass number between $A = 40$ and 120. These elements are comparatively more stable and not radioactive.

(3) For higher mass numbers, the curve reduces slowly and \overline{BE} for uranium is about 7.6 MeV. They are unstable and radioactive.

From Figure 8.24, if two light nuclei with $A < 28$ combine with a nucleus with $A < 56$, the binding energy per nucleon is more for final nucleus than initial nuclei. Thus, if the lighter elements combine to produce a nucleus of medium value A , a large amount of energy will be released. This is the basis of nuclear fusion and is the principle of the hydrogen bomb.

(4) If a nucleus of heavy element is split (fission) into two or more nuclei of medium value A , the energy released would again be large. The atom bomb is based on this principle and huge energy of atom bombs comes from this fission when it is uncontrolled. Fission is explained in the section 8.7

EXAMPLE 8.10

Compute the binding energy per nucleon of ${}^4_2\text{He}$ nucleus.

Solution

From example 8.9, we found that the BE of ${}^4_2\text{He} = 28 \text{ MeV}$

Binding energy per nucleon $= \overline{BE} = 28 \text{ MeV} / 4 = 7 \text{ MeV}$.

8.5

NUCLEAR FORCE

Nucleus contains protons and neutrons. From electrostatics, we learnt that like charges repel each other. In the nucleus, the protons are separated by a distance of about a few Fermi (10^{-15} m), they must exert on each other a very strong repulsive force. For example,

the electrostatic repulsive force between two protons separated by a distance 10^{-15} m

$$F = k \times \frac{q^2}{r^2} = 9 \times 10^9 \times \frac{(1.6 \times 10^{-19})^2}{(10^{-15})^2} \approx 230 \text{ N}$$

The acceleration experienced by a proton due to the force of 230 N is

$$a = \frac{F}{m} = \frac{230 \text{ N}}{1.67 \times 10^{-27} \text{ kg}} \approx 1.4 \times 10^{29} \text{ m s}^{-2}.$$

This is nearly 10^{28} times greater than the acceleration due to gravity. So if the protons in the nucleus experience only the electrostatic force, then the nucleus would fly apart in an instant. Then how protons are held together in nucleus?

From this observation, it was concluded that there must be a strong attractive force between protons to overcome the repulsive Coulomb's force. This attractive force which holds the nucleus together is called strong nuclear force. The properties of strong nuclear force were understood through various experiments carried out between 1930s and 1950s. A few properties of strong nuclear force are

- (i) The strong nuclear force is of very short range, acting only up to a distance of a few Fermi. But inside the nucleus, the repulsive Coulomb force or attractive gravitational forces between two protons are much weaker than the strong nuclear force between two protons. Similarly, the gravitational force between two neutrons is also much weaker than strong nuclear force between the neutrons. So nuclear force is the strongest force in nature.
- (ii) The strong nuclear force is attractive and acts with an equal strength between proton-proton, proton-neutron, and neutron – neutron.

(iii) Strong nuclear force does not act on the electrons. So it does not alter the chemical properties of the atom.

8.6

RADIOACTIVITY

In the binding energy curve, the stability of the nucleus that has $Z > 82$ starts to decrease and these nuclei are called unstable nuclei. Some of the unstable nuclei decay naturally by emitting some kind of particles to form a stable nucleus. The elements of atomic number $Z > 82$ and isotopes of lighter nuclei belong to naturally-occurring radioactive nuclei. Each of these radioactive nuclei decays to another nucleus by the emission of ${}^4_2\text{He}$ nucleus (α -decay) or electron or positron (β -decay) or gamma rays (γ -decay).

The phenomenon of spontaneous emission of highly penetrating radiations such as α , β and γ rays by an element is called radioactivity and the substances which emit these radiations are called radioactive elements. These radioactive elements can be heavy elements ($Z > 82$), isotopes of lighter and heavy elements and these isotopes are called radioisotopes. For example, carbon isotope ${}^{14}_6\text{C}$ is radioactive but ${}^{12}_6\text{C}$ is not.

Radioisotopes have a variety of applications such as carbon dating, cancer treatment, etc. When radioactive nucleus undergoes decay, the mass of the system decreases – that is, the mass of the initial nucleus before decay is always greater than the sum of the mass of the final nucleus and that of the emitted particle. When this difference in mass $\Delta m < 0$, it appears as the energy according to Einstein's relation $E = |\Delta m|c^2$.

The phenomenon of radioactivity was first discovered by Henri Becquerel in 1896. Later, Marie Curie and her husband Pierre Curie did a series of experiments in detail to understand the phenomenon of radioactivity. In India, Saha Institute of Nuclear Physics (SINP), Kolkata is the premier institute pursuing active research in nuclear physics.



Note During early days of nuclear physics research, the term 'radiation' was used to denote the emanations from radioactive nuclei. Now we know that α rays are in fact ${}^4_2\text{He}$ nuclei and β rays are electrons or positrons. Certainly, they are not electromagnetic radiation. The γ ray alone is electromagnetic radiation.

8.6.1 Alpha decay

When unstable nuclei decay by emitting an α -particle (${}^4_2\text{He}$ nucleus), it loses two protons and two neutrons. As a result, its atomic number Z decreases by 2, the mass number decreases by 4. We write the alpha decay process symbolically in the following way

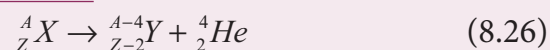

Here X is called the parent nucleus and Y is called the daughter nucleus.

Example: Decay of Uranium ${}^{238}_{92}\text{U}$ to thorium ${}^{234}_{90}\text{Th}$ with the emission of ${}^4_2\text{He}$ nucleus (α -particle)

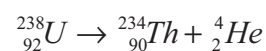

As already mentioned, the total mass of the daughter nucleus and ${}^4_2\text{He}$ nucleus is always

less than that of the parent nucleus. The difference in mass ($\Delta m = m_X - m_Y - m_\alpha$) is released as energy called **disintegration energy** Q and is given by

$$Q = (m_X - m_Y - m_\alpha)c^2 \quad (8.27)$$

Note that for spontaneous decay (natural radioactivity) $Q > 0$. In alpha decay process, the disintegration energy is certainly positive ($Q > 0$). In fact, the disintegration energy Q is also the net kinetic energy gained in the decay process or if the parent nucleus is at rest, Q is the total kinetic energy of daughter nucleus and the ${}^4_2\text{He}$ nucleus. Suppose $Q < 0$, then the decay process cannot occur spontaneously and energy must be supplied to induce the decay.



Note In alpha decay, why does the unstable nucleus emit ${}^4_2\text{He}$ nucleus? Why it does not emit four separate nucleons? After all ${}^4_2\text{He}$ consists of two protons and two neutrons. For example, if ${}^{238}_{92}\text{U}$ nucleus decays into ${}^{234}_{90}\text{Th}$ by emitting four separate nucleons (two protons and two neutrons), then the disintegration energy Q for this process turns out to be negative. It implies that the total mass of products is greater than that of parent (${}^{238}_{92}\text{U}$) nucleus. This kind of process cannot occur in nature because it would violate conservation of energy. In any decay process, the conservation of energy, conservation of linear momentum and conservation of angular momentum must be obeyed.

EXAMPLE 8.11

- (a) Calculate the disintegration energy when stationary ${}^{232}_{92}\text{U}$ nucleus decays to thorium ${}^{228}_{90}\text{Th}$ with the emission of α particle. The atomic masses are of ${}^{232}_{92}\text{U} = 232.037156u$, ${}^{228}_{90}\text{Th} = 228.028741u$ and ${}^4_2\text{He} = 4.002603u$
- (b) Calculate kinetic energies of ${}^{228}_{90}\text{Th}$ and α -particle and their ratio.

Solution

The difference in masses

$$\begin{aligned} \Delta m &= (m_U - m_{Th} - m_\alpha) \\ &= (232.037156 - 228.028741 - 4.002603)u \end{aligned}$$

The mass lost in this decay = $0.005812u$

Since $1u = 931\text{MeV}$, the energy Q released is

$$\begin{aligned} Q &= (0.005812u) \times (931\text{MeV}/u) \\ &= 5.41\text{MeV} \end{aligned}$$

This disintegration energy Q appears as the kinetic energy of α particle and the daughter nucleus.

In any decay, the total linear momentum must be conserved.

Total linear momentum of the parent nucleus = total linear momentum of the daughter nucleus + α particle

Since before decay, the uranium nucleus is at rest, its momentum is zero.

By applying conservation of momentum, we get

$$\begin{aligned} 0 &= m_{Th}\vec{v}_{Th} + m_\alpha\vec{v}_\alpha \\ m_\alpha\vec{v}_\alpha &= -m_{Th}\vec{v}_{Th} \end{aligned}$$

It implies that the alpha particle and daughter nucleus move in opposite directions.

In magnitude $m_{\alpha} v_{\alpha} = m_{Th} v_{Th}$

The velocity of α particle $v_{\alpha} = \frac{m_{Th}}{m_{\alpha}} v_{Th}$

Note that $\frac{m_{Th}}{m_{\alpha}} > 1$, so $v_{\alpha} > v_{Th}$. The ratio of the kinetic energy of α particle to the daughter nucleus

$$\frac{K.E_{\alpha}}{K.E_{Th}} = \frac{\frac{1}{2} m_{\alpha} v_{\alpha}^2}{\frac{1}{2} m_{Th} v_{Th}^2}$$

By substituting, the value of v_{α} into the above equation, we get

$$\frac{K.E_{\alpha}}{K.E_{Th}} = \frac{m_{Th}}{m_{\alpha}} = \frac{228.02871}{4.002603} = 57$$

The kinetic energy of α particle is 57 times greater than the kinetic energy of the daughter nucleus (${}_{90}^{228}Th$).

The disintegration energy $Q =$ total kinetic energy of products

$$K.E_{\alpha} + K.E_{Th} = 5.41 MeV$$

$$57K.E_{Th} + K.E_{Th} = 5.41 MeV$$

$$K.E_{Th} = \frac{5.41}{58} MeV = 0.093 MeV$$

$$K.E_{\alpha} = 57K.E_{Th} = 57 \times 0.093 = 5.301 MeV$$

In fact, 98% of total kinetic energy is taken by the α particle.

8.6.2 Beta decay

In beta decay, a radioactive nucleus emits either electron or positron. If electron (e^{-}) is emitted, it is called β^{-} decay and if positron (e^{+}) is emitted, it is called β^{+} decay. The positron is an anti-particle of an electron whose mass is same as that of electron – that is, $+e$. Both positron and electron are referred to as beta particles.

β^{-} decay:

In β^{-} decay, the atomic number of the nucleus increases by one but mass number remains the same. This decay is represented by

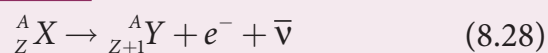

It implies that the element X becomes Y by giving out an electron and antineutrino ($\bar{\nu}$). In otherwords, in each β^{-} decay, one neutron in the nucleus of X is converted into a proton by emitting an electron (e^{-}) and antineutrino. It is given by

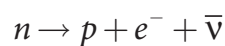

Where p -proton, $\bar{\nu}$ -antineutrino.

Example: Carbon (${}^14_6 C$) is converted into nitrogen (${}^14_7 N$) through β^{-} decay.

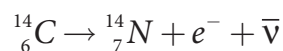

β^{+} decay:

In β^{+} decay, the atomic number is decreased by one and the mass number remains the same. This decay is represented by

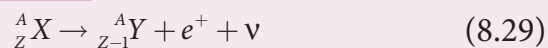

It implies that the element X becomes Y by giving out an positron and neutrino (ν). In otherwords, for each β^{+} decay, a proton in the nucleus of X is converted into a neutron by emitting a positron (e^{+}) and a neutrino. It is given by

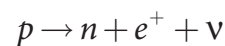

However a single proton (not inside any nucleus) cannot have β^{+} decay due to energy conservation, because neutron mass is larger than proton mass. But a single neutron (not inside any nucleus) can have β^{-} decay.



A very interesting application of alpha decay is in smoke detectors which prevent us from any hazardous fire.

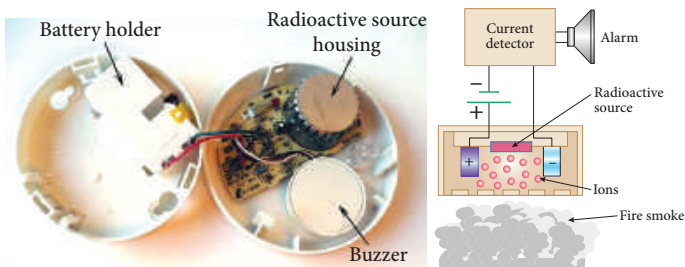

The smoke detector uses around 0.2 mg of man-made weak radioactive isotope called americium (${}_{95}^{241}\text{Am}$). This radioactive source is placed between two oppositely charged metal plates and α radiations from ${}_{95}^{241}\text{Am}$ continuously ionize the nitrogen, oxygen molecules in the air space between the plates. As a result, there will be a continuous flow of small steady current in the circuit. If smoke enters, the radiation is being absorbed by the smoke particles rather than air molecules. As a result, the ionization and along with it the current is reduced. This drop in current is detected by the circuit and alarm starts.

The radiation dosage emitted by americium is very much less than safe level, so it can be considered harmless.

Example: Sodium (${}_{11}^{22}\text{Na}$) is converted into neon (${}_{10}^{22}\text{Ne}$) through β^+ decay.

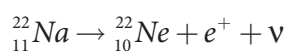

It is important to note that the electron or positron which comes out from nuclei during beta decay never present inside the nuclei rather they are produced during the conversion of neutron into proton or proton into neutron inside the nucleus.

Neutrino:

Initially, it was thought that during beta decay, a neutron in the parent nucleus is converted to the daughter nuclei by emitting only electron as given by

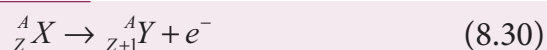

But the kinetic energy of electron coming out of the nucleus did not match with the experimental results. In alpha decay, the alpha particle takes only certain

allowed discrete energies whereas in beta decay, it was found that the beta particle (i.e, electron) have a continuous range of energies. But the conservation of energy and momentum gives specific single values for electron energy and the recoiling nucleus Y. It seems that the conservation of energy, momentum are violated and could not be explained why energy of beta particle have continuous range of values. So beta decay remained as a puzzle for several years.

After a detailed theoretical and experimental study, in 1931 W.Pauli proposed a third particle which must be present in beta decay to carry away missing energy and momentum. Fermi later named this particle the *neutrino* (little neutral one) since it has no charge, have very little mass. For many years, the neutrino (symbol ν , Greek *nu*) was hypothetical and could not be verified experimentally. Finally, the

neutrino was detected experimentally in 1956 by Fredrick Reines and Clyde Cowan. Later Reines received Nobel prize in physics in the year 1995 for his discovery.

The neutrino has the following properties

- It has zero charge
- It has an antiparticle called anti-neutrino.
- Recent experiments showed that the neutrino has very tiny mass.
- It interacts very weakly with the matter. Therefore, it is very difficult to detect. In fact, in every second, trillions of neutrinos coming from the sun are passing through our body without any interaction.

8.6.3 Gamma decay

In α and β decay, the daughter nucleus is in the excited state most of the time. The typical life time of excited state is approximately 10^{-11} s. So this excited state nucleus immediately returns to the ground state or lower energy state by emitting highly energetic photons called γ rays. In fact, when the atom is in the excited state, it returns to the ground state by emitting photons of energy in the order of few eV. But when the excited state nucleus returns to its ground state, it emits a highly energetic photon (γ rays) of energy in the order of MeV. The gamma decay is given by

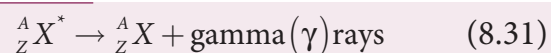

Here the asterisk(*) means excited state nucleus. In gamma decay, there is no change in the mass number or atomic number of the nucleus.

Boron (${}^{12}_5B$) has two beta decay modes as shown in Figure 8.25:

- (1) it undergoes beta decay directly into ground state carbon (${}^{12}_6C$) by emitting

an electron of maximum of energy 13.4 MeV.

- (2) it undergoes beta decay to an excited state of carbon (${}^{12}_6C^*$) by emitting an electron of maximum energy 9.0 MeV followed by gamma decay to ground state by emitting a photon of energy 4.4 MeV.

It is represented by

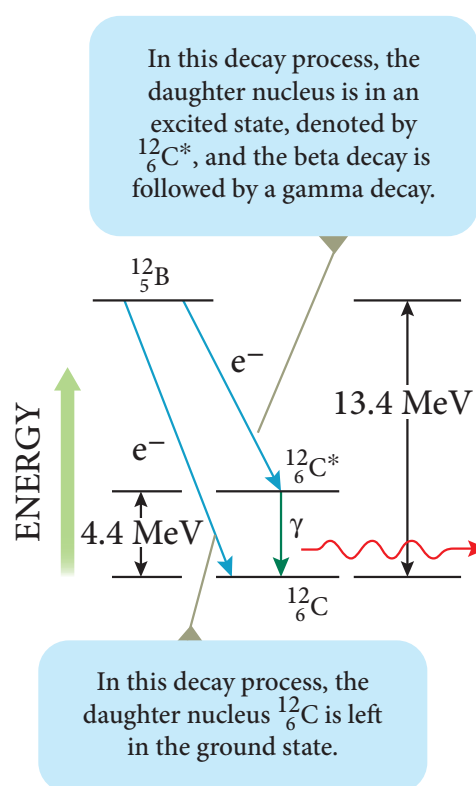
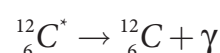
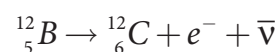

Figure 8.25 Gamma decay

8.6.4 Law of radioactive decay

In the previous section, the decay process of a single radioactive nucleus was discussed. In practice, we have bulk material of radioactive sample which contains a vast number of the radioactive nuclei and not all the radioactive nucleus in a sample

decay at the same time. It decays over a period of time and this decay is basically a random process. It implies that we cannot predict which nucleus is going to decay or rather we can determine like probabilistic basis (like tossing a coin). We can calculate approximately how many nuclei in a sample are decayed over a period of time.

At any instant t , the number of decays per unit time, called rate of decay $\left(\frac{dN}{dt}\right)$ is proportional to the number of nuclei (N) at the same instant.

$$\frac{dN}{dt} \propto N$$

By introducing a proportionality constant, the relation can be written as

$$\frac{dN}{dt} = -\lambda N \quad (8.32)$$

Here proportionality constant λ is called decay constant which is different for different radioactive sample and the negative sign in the equation implies that the N is decreasing with time.

By rewriting the equation (8.32), we get

$$dN = -\lambda N dt \quad (8.33)$$

Here dN represents the number of nuclei decaying in the time interval dt .

Let us assume that at time $t=0$ s, the number of nuclei present in the radioactive sample is N_0 . By integrating the equation (8.33), we can calculate the number of undecayed nuclei N at any time t .

From equation (8.33), we get

$$\frac{dN}{N} = -\lambda dt \quad (8.34)$$

$$\int_{N_0}^N \frac{dN}{N} = -\int_0^t \lambda dt$$

$$[\ln N]_{N_0}^N = -\lambda t$$

$$\ln \left[\frac{N}{N_0} \right] = -\lambda t$$

Taking exponentials on both sides, we get

$$N = N_0 e^{-\lambda t} \quad (8.35)$$

[Note: $e^{\ln x} = e^y \Rightarrow x = e^y$]

Equation (8.35) is called the law of radioactive decay. Here N denotes the number of undecayed nuclei present at any time t and N_0 denotes the number of nuclei at initial time $t=0$. Note that the number of atoms is decreasing exponentially over the time. This implies that the time taken for all the radioactive nuclei to decay will be infinite. Equation (8.35) is plotted in Figure 8.26.

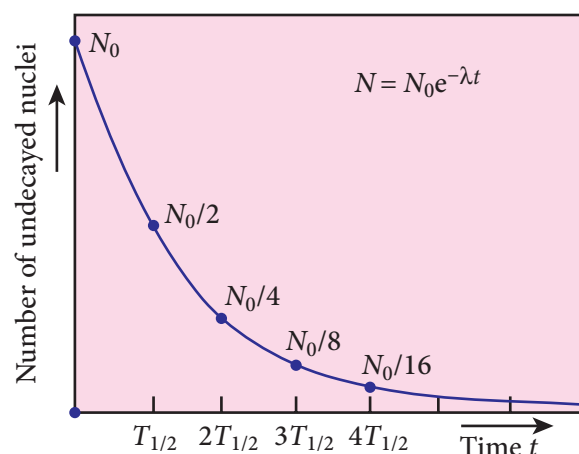

Figure 8.26 Law of radioactive decay

We can also define another useful quantity called activity (R) or decay rate which is the number of nuclei decayed per second and it is denoted as $R = \left| \frac{dN}{dt} \right|$. Note that activity R is a positive quantity.

From equation (8.35), we get

$$R = \left| \frac{dN}{dt} \right| = \lambda N_0 e^{-\lambda t} \quad (8.36)$$

$$R = R_0 e^{-\lambda t} \quad (8.37)$$

where $R_0 = \lambda N_0$

The equation (8.37) is also equivalent to radioactive law of decay. Here R_0 is the activity of the sample at $t=0$ and R is the activity of the sample at any time t . From equation (8.37), activity also shows exponential decay behavior. The activity R also can be expressed in terms of number of undecayed atoms present at any time t .

From equation (8.37), since $N = N_0 e^{-\lambda t}$, we write

$$R = \lambda N \quad (8.38)$$

Equation (8.35) implies that the activity at any time t is equal to the product of decay constant and number of undecayed nuclei at the same time t . Since N decreases over time, R also decreases.

The SI unit of activity R is Becquerel and one Becquerel (Bq) is equal to one decay per second. There is also another standard unit for the activity called Curie(Ci).

1 Curie = 1 Ci = 3.7×10^{10} decays per second

1 Ci = 3.7×10^{10} Bq



Note Initially one curie was defined as number of decays per second in 1 g of radium and it is equal to 3.7×10^{10} decays/s.

8.6.5 Half-life

It is difficult to calculate the time taken by a given a sample of N atoms to decay. However, we can calculate the time taken by the given sample of atoms to reduce some fraction of the initial amount.

We can define the half-life $T_{1/2}$ as the time required for the number of atoms

initially present to reduce to one half of the initial amount.

The half-life is the important characteristic of every radioactive sample. Some radioactive nuclei are known to have half-life as long as 10^{14} years and some nucleus have very shorter life time (10^{-14} s).

We can express half-life in terms of the decay constant. At $t = T_{1/2}$, the number of undecayed nuclei $N = \frac{N_0}{2}$.

By substituting this value in to the equation (8.35), we get

$$\frac{N_0}{2} = N_0 e^{-\lambda T_{1/2}}$$

$$\frac{1}{2} = e^{-\lambda T_{1/2}} \text{ or } e^{\lambda T_{1/2}} = 2$$

Taking logarithm on both sides and rearranging the terms,

$$T_{1/2} = \frac{\ln 2}{\lambda} = \frac{0.6931}{\lambda} \quad (8.39)$$



Note One should not think that shorter half-life material is safer than longer half-life material because it will not last long. The shorter half-life sample will have higher activity and it is more 'radioactive' which is more harmful.

If the number of atoms present at $t=0$ is N_0 , then $\frac{N_0}{2}$ atoms remain undecayed in first half-life and $\frac{N_0}{4}$ atoms remain undecayed after second half life and so on. In general, after n half-lives, the number of nuclei remaining undecayed is given by

$$N = \left(\frac{1}{2}\right)^n N_0 \quad (8.40)$$

where n can be integer or non-integer. Since the activity of radioactive sample also

obeys the exponential decay law, we can also write an equation for an activity similar to equation (8.36).

After n half-lives, the activity or decay rate of any radioactive sample is

$$R = \left(\frac{1}{2}\right)^n R_0 \quad (8.41)$$

Mean life (τ):

When the radioactive nucleus undergo the decay, the nucleus which disintegrates first has zero life time and the nucleus which decay last has an infinite lifetime. The actual life time for each nucleus varies from zero to infinity. Therefore, it is meaningful to define average life or mean life time τ , that the nucleus survives before it decays.

The mean life time of the nucleus is the ratio of sum or integration of life times of all nuclei to the total number nuclei present initially.

The total number of nuclei decaying in the time interval from t to $t + \Delta t$ is equal to $R\Delta t = \lambda N_0 e^{-\lambda t} \Delta t$. It implies that until the time t , this $R\Delta t$ number of nuclei lived. So the life time of these $R\Delta t$ nuclei is equal to be $tR\Delta t$. In the limit $\Delta t \rightarrow 0$, the total life time of all the nuclei would be the integration of $tRdt$ from the limit $t = 0$ to $t = \infty$.

Mean life

$$\tau = \frac{\int_0^{\infty} t [Rdt]}{N_0} = \frac{\int_0^{\infty} t [\lambda N_0 e^{-\lambda t} dt]}{N_0} \quad (8.42)$$

After a few integration (refer box item), the expression for mean life time,

$$\tau = \frac{1}{\lambda} \quad (8.43)$$

Note that mean life and decay constant is inversely proportional to each other.

Using mean life, the half-life can be rewritten as

$$T_{1/2} = \tau \ln 2 = 0.6931 \tau \quad (8.44)$$

Mean life : Not for examination

The integration in the equation (8.42) can be performed using integration by parts.

$$\tau = \frac{\int_0^{\infty} \lambda N_0 t e^{-\lambda t} dt}{N_0} = \frac{\lambda N_0 \int_0^{\infty} t e^{-\lambda t} dt}{N_0}$$

$$\tau = \lambda \int_0^{\infty} t e^{-\lambda t} dt$$

$$u = t \quad dv = e^{-\lambda t} dt$$

$$\tau = \lambda \int_0^{\infty} t e^{-\lambda t} dt = \lambda \left[\frac{t e^{-\lambda t}}{-\lambda} \right]_0^{\infty} - \lambda \int_0^{\infty} \left[\frac{e^{-\lambda t}}{-\lambda} \right] dt$$

By substituting the limits, the first term in the above equation becomes zero.

$$\tau = \int_0^{\infty} e^{-\lambda t} dt = -\frac{1}{\lambda} \left[e^{-\lambda t} \right]_0^{\infty} = \frac{1}{\lambda}$$

EXAMPLE 8.12

Calculate the number of nuclei of carbon-14 undecayed after 22,920 years if the initial number of carbon-14 atoms is 10,000. The half-life of carbon-14 is 5730 years.

Solution

To get the time interval in terms of half-life,

$$n = \frac{t}{T_{1/2}} = \frac{22,920 \text{ yr}}{5730 \text{ yr}} = 4$$

The number of nuclei remaining undecayed after 22,920 years,

$$N = \left(\frac{1}{2}\right)^n N_0 = \left(\frac{1}{2}\right)^4 \times 10,000$$

$$N = 625$$

EXAMPLE 8.13

A radioactive sample has $2.6\mu\text{g}$ of pure ${}^{13}_7\text{N}$ which has a half-life of 10 minutes.

(a) How many nuclei are present initially? (b) What is the activity initially? (c) What is the activity after 2 hours? (d) Calculate mean life of this sample.

Solution

(a) To find N_0 , we have to find the number of ${}^{13}_7\text{N}$ atoms in $2.6\mu\text{g}$. The atomic mass of nitrogen is 13. Therefore, 13 g of ${}^{13}_7\text{N}$ contains Avogadro number (6.02×10^{23}) of atoms.

In 1 g, the number of ${}^{13}_7\text{N}$ is equal to be $\frac{6.02 \times 10^{23}}{13}$ atoms. So the number of ${}^{13}_7\text{N}$ atoms in $2.6\mu\text{g}$ is

$$N_0 = \frac{6.02 \times 10^{23}}{13} \times 2.6 \times 10^{-6} = 12.04 \times 10^{16} \text{ atoms}$$

(b) To find the initial activity R_0 , we have to evaluate decay constant λ

$$\lambda = \frac{0.6931}{T_{1/2}} = \frac{0.6931}{10 \times 60} = 1.155 \times 10^{-3} \text{ s}^{-1}$$

Therefore

$$\begin{aligned} R_0 &= \lambda N_0 = 1.155 \times 10^{-3} \times 12.04 \times 10^{16} \\ &= 13.90 \times 10^{13} \text{ decays/s} \\ &= 13.90 \times 10^{13} \text{ Bq} \end{aligned}$$

In terms of a curie,

$$R_0 = \frac{13.90 \times 10^{13}}{3.7 \times 10^{10}} = 3.75 \times 10^3 \text{ Ci}$$

since $1\text{Ci} = 3.7 \times 10^{10} \text{ Bq}$

(c) Activity after 2 hours can be calculated in two different ways:

$$\text{Method 1: } R = R_0 e^{-\lambda t}$$

$$\text{At } t = 2 \text{ hr} = 7200 \text{ s}$$

$$R = 3.75 \times 10^3 \times e^{-7200 \times 1.155 \times 10^{-3}}$$

$$R = 3.75 \times 10^3 \times 2.4 \times 10^{-4} = 0.9 \text{ Ci}$$

$$\text{Method 2: } R = \left(\frac{1}{2}\right)^n R_0$$

$$\text{Here } n = \frac{120 \text{ min}}{10 \text{ min}} = 12$$

$$R = \left(\frac{1}{2}\right)^{12} \times 3.75 \times 10^3 \approx 0.9 \text{ Ci}$$

$$\begin{aligned} \text{(d) mean life } \tau &= \frac{T_{1/2}}{0.6931} = \frac{10 \times 60}{0.6931} \\ &= 865.67 \text{ s} \end{aligned}$$

8.6.6 Carbon dating

The interesting application of beta decay is radioactive dating or carbon dating. Using this technique, the age of an ancient object can be calculated. All living organisms absorb carbon dioxide (CO_2) from air to synthesize organic molecules. In this absorbed CO_2 , the major part is ${}^{12}_6\text{C}$ and very small fraction (1.3×10^{-12}) is radioactive ${}^{14}_6\text{C}$ whose half-life is 5730 years.

Carbon-14 in the atmosphere is always decaying but at the same time, cosmic rays from outer space are continuously bombarding the atoms in the atmosphere which produces ${}^{14}_6\text{C}$. So the continuous production and decay of ${}^{14}_6\text{C}$ in the atmosphere keep the ratio of ${}^{14}_6\text{C}$ to ${}^{12}_6\text{C}$ always constant. Since our human body, tree or any living organism continuously absorb CO_2 from the atmosphere, the ratio of ${}^{14}_6\text{C}$ to ${}^{12}_6\text{C}$ in the living organism is also nearly constant. But when the organism

dies, it stops absorbing CO_2 . Since ^{14}C starts to decay, the ratio of ^{14}C to ^{12}C in a dead organism or specimen decreases over the years. Suppose the ratio of ^{14}C to ^{12}C in the ancient tree pieces excavated is known, then the age of the tree pieces can be calculated.

EXAMPLE 8.14

Keezhadi (கீழ்ப்படி), a small hamlet, has become one of the very important archeological places of Tamilandu. It is located in Sivagangai district. A lot of artefacts (gold coins, pottery, beads, iron tools, jewellery and charcoal, etc.) have been unearthed in Keezhadi which have given substantial evidence that an ancient urban civilization had thrived on the banks of river Vaigai. To determine the age of those materials, the charcoal of 200 g sent for carbon dating is given in the following figure (b). The activity of ^{14}C is found to be 38 decays/s. Calculate the age of charcoal.



Figure (a) Keezhadi – excavation site



Figure (b) – Characol which was sent for carbon dating

Solution

To calculate the age, we need to know the initial activity (R_0) of the characol (when the sample was alive).

The activity R of the sample

$$R = R_0 e^{-\lambda t} \quad (1)$$

To find the time t , rewriting the above equation (1),
$$e^{\lambda t} = \frac{R_0}{R}$$

By taking the logarithm on both sides, we get
$$t = \frac{1}{\lambda} \ln \left(\frac{R_0}{R} \right) \quad (2)$$

Here $R = 38$ decays/s = 38 Bq.

To find decay constant, we use the equation

$$\lambda = \frac{0.6931}{T_{1/2}} = \frac{0.6931}{5730 \text{ yr} \times 3.156 \times 10^7 \text{ s/yr}}$$

$$[\because 1 \text{ yr} = 365.25 \times 24 \times 60 \times 60 \text{ s} = 3.156 \times 10^7 \text{ s}]$$

$$\lambda = 3.83 \times 10^{-12} \text{ s}^{-1}$$

To find the initial activity R_0 , we use the equation $R_0 = \lambda N_0$. Here N_0 is the number of carbon-14 atoms present in the sample when it was alive. The mass of the characol is 200 g. In 12 g of carbon, there are 6.02×10^{23} carbon atoms. So 200 g contains,

$$\frac{6.02 \times 10^{23} \text{ atoms/mol}}{12 \text{ g/mol}} \times 200 \approx 1 \times 10^{25} \text{ atoms}$$

When the tree(sample) was alive, the ratio of ^{14}C to ^{12}C is 1.3×10^{-12} . So the total number of carbon-14 atoms is given by

$$N_0 = 1 \times 10^{25} \times 1.3 \times 10^{-12} = 1.3 \times 10^{13} \text{ atoms}$$

The initial activity

$$R_0 = 3.83 \times 10^{-12} \times 1.3 \times 10^{13} \approx 50 \text{ decays/s} \\ = 50 \text{ Bq}$$

By substituting the value of R_0 and λ in the equation (2), we get

$$t = \frac{1}{3.83 \times 10^{-12}} \times \ln \left[\frac{50}{38} \right]$$

$$t = \frac{0.27}{3.83} \times 10^{12} \approx 7 \times 10^{10} \text{ sec}$$

In years

$$t = \frac{7 \times 10^{10} \text{ s}}{3.156 \times 10^7 \text{ s/yr}} \approx 2200 \text{ years}$$

In fact, the excavated materials were sent for carbon dating to USA by Archeological Department of Tamilnadu and the report confirmed that the age of Keezhadi artefacts lies between 2200 years to 2500 years (Sangam era- 400 BC to 200 BC). The Keezhadi excavations experimentally proved that urban civilization existed in Tamil Nadu even 2000 years ago!

8.6.7 Discovery of Neutrons

In 1930, two German physicists Bothe and Becker found that when beryllium was bombarded with α particles, highly penetrating radiation was emitted. This radiation was capable of penetrating the thick layer of lead and was unaffected by the electric and magnetic fields. Initially, it was thought as γ radiation. But in the year 1932, James Chadwick discovered that those radiations are not EM waves but they are particles of mass little greater than the mass of the proton and had no charge. He called them as neutrons. The above reaction can be written as

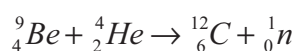

where ${}^1_0\text{n}$ denotes neutron.

Neutrons are stable inside the nucleus. But outside the nucleus they are unstable. If the neutron comes out of the nucleus (free neutron), it decays with emission of proton,

electron, and antineutrino with the half life of 13 minutes.

Neutrons are classified according to their kinetic energy as (i) slow neutrons (0 to 1000 eV) (ii) fast neutrons (0.5 MeV to 10 MeV). The neutrons with average energy of about 0.025 eV in thermal equilibrium are called thermal neutron, because at 298K, the thermal energy $kT = 0.025 \text{ eV}$. Slow and fast neutrons play a vital role in nuclear reactors.

8.7

NUCLEAR FISSION

In 1939, German scientists Otto Hahn and F. Strassman discovered that when uranium nucleus is bombarded with a neutron, it breaks up into two smaller nuclei of comparable masses with the release of energy. **The process of breaking up of the nucleus of a heavier atom into two smaller nuclei with the release of a large amount of energy is called nuclear fission.** The fission is accompanied by the release of neutrons. The energy that is released in the nuclear fission is of many orders of magnitude greater than the energy released in chemical reactions.

Uranium undergoes fission reaction in 90 different ways. The most common fission reactions of ${}^{235}_{92}\text{U}$ nuclei are shown here.

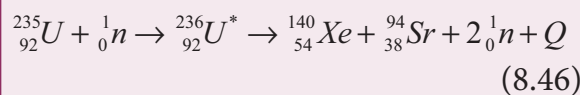
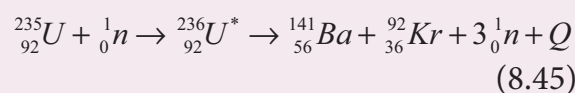

Here Q is energy released during the decay of each uranium nuclei. When the slow neutron is absorbed by the uranium nuclei, the mass number increases by one and goes to an excited state ${}^{236}_{92}\text{U}^*$. But this

excited state does not last longer than 10^{-12} s and decay into two daughter nuclei along with 2 or 3 neutrons. From each reaction, on an average, 2.5 neutrons are emitted. It is shown in Figure 8.27

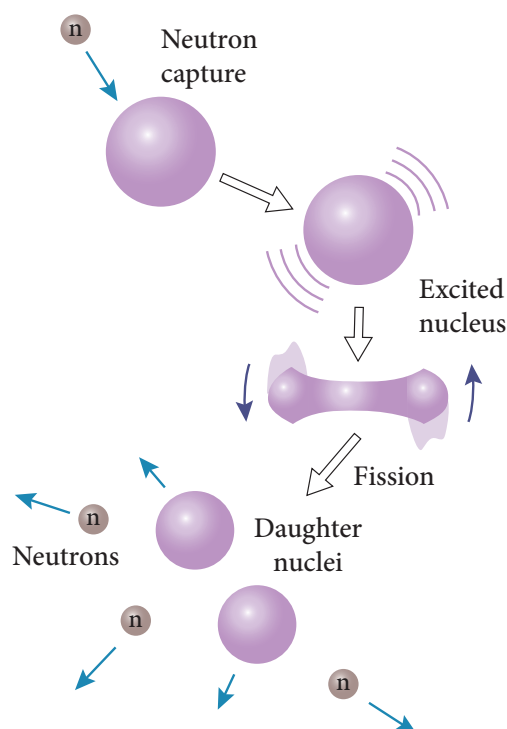
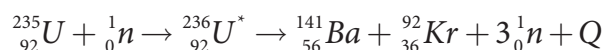

Figure 8.27 Nuclear fission

Energy released in fission:

We can calculate the energy (Q) released in each uranium fission reaction. We choose the most favorable fission which is given in the equation (8.45).



$$\text{Mass of } {}_{92}^{235}\text{U} = 235.045733 \text{ u}$$

$$\text{Mass of } {}_0^1\text{n} = 1.008665 \text{ u}$$

$$\text{Total mass of reactant} = 236.054398 \text{ u}$$

$$\text{Mass of } {}_{56}^{141}\text{Ba} = 140.9177 \text{ u}$$

$$\text{Mass of } {}_{36}^{92}\text{Kr} = 91.8854 \text{ u}$$

$$\text{Mass of 3 neutrons} = 3.025995 \text{ u}$$

$$\text{The total mass of products} = 235.829095 \text{ u}$$

$$\begin{aligned} \text{Mass defect } \Delta m &= 236.054398 \text{ u} - 235.829095 \text{ u} \\ &= 0.225303 \text{ u} \end{aligned}$$

$$\begin{aligned} \text{So the energy released in each fission} &= \\ 0.225303 \times 931 \text{ MeV} &\approx 200 \text{ MeV} \end{aligned}$$

This energy first appears as kinetic energy of daughter nuclei and neutrons. But later, this kinetic energy is transferred to the surrounding matter as heat.

Chain reaction:

When one ${}_{92}^{235}\text{U}$ nucleus undergoes fission, the energy released might be small. But from each fission reaction, three neutrons are released. These three neutrons cause further fission in another three ${}_{92}^{235}\text{U}$ nuclei which in turn produce nine neutrons. These nine neutrons initiate fission in another 27 ${}_{92}^{235}\text{U}$ nuclei and so on. This is called a chain reaction and the number of neutrons goes on increasing almost in geometric progression. It is shown in Figure 8.28.

There are two kinds of chain reactions: (i) uncontrolled chain reaction (ii) controlled chain reaction. In an uncontrolled chain reaction, the number of neutrons multiply indefinitely and the entire amount of energy released in a fraction of second.

The atom bomb is an example of nuclear fission in which uncontrolled chain reaction occurs. Atom bombs produce massive destruction for mankind. During World War II, in the year 1946 August 6 and 9, USA dropped two atom bombs in two places of Japan, Hiroshima and Nagasaki. As a result, lakhs of people were killed and the two cities were completely destroyed. Even now the people who are living in those places have side effects caused by the explosion of atom bombs.

It is possible to calculate the typical energy released in a chain reaction. In the

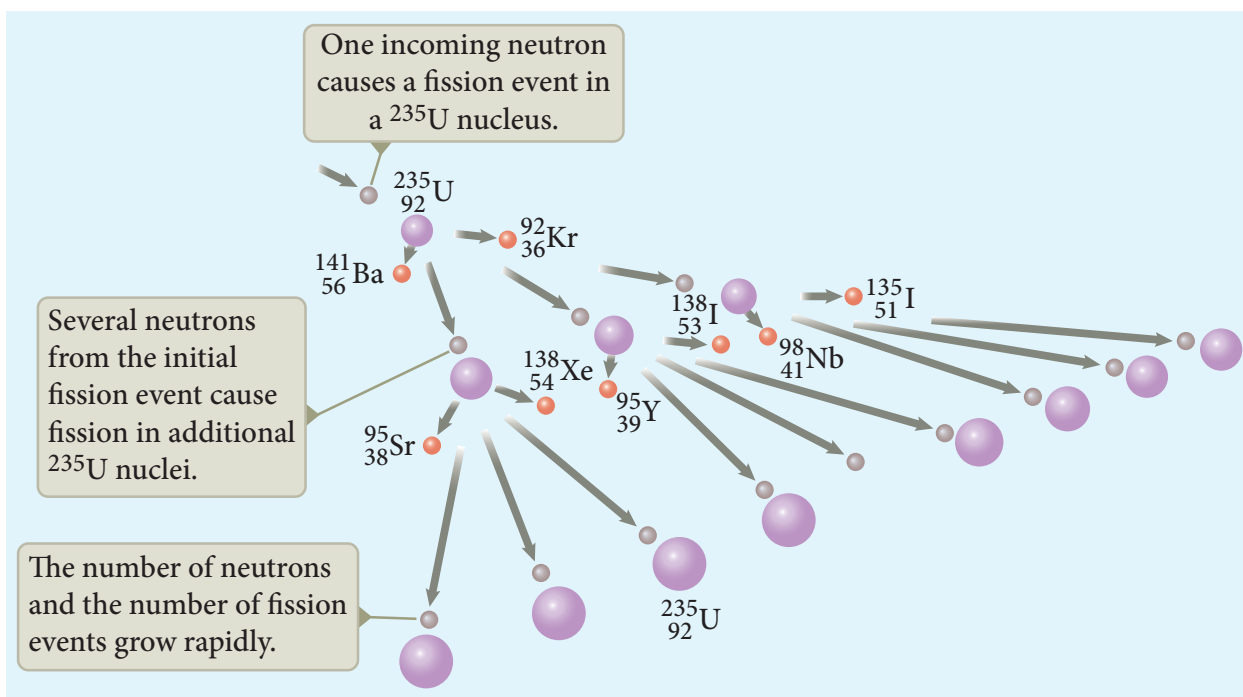

Figure 8.28 Nuclear chain reaction

first step, one neutron initiates the fission of one nucleus by producing three neutrons and energy of about 200 MeV. In the second step, three nuclei undergo fission, in third step nine nuclei undergo fission, in fourth step 27 nuclei undergo fission and so on. In the 100th step, the number of nuclei which undergoes fission is around 2.5×10^{40} . The total energy released after 100th step is $2.5 \times 10^{40} \times 200 \text{ MeV} = 8 \times 10^{29} \text{ J}$. It is really an enormous amount of energy which is equivalent to electrical energy required in Tamilnadu for several years.

If the chain reaction is controllable, then we can harvest an enormous amount of energy for our needs. It is achieved in a controlled chain reaction. In the controlled chain reaction, the average number of neutron released in each stage is kept as one such that it is possible to store the released energy. In nuclear reactors, the controlled chain reaction is achieved and the produced energy is used for power generation or for research purpose.

EXAMPLE 8.15

Calculate the amount of energy released when 1 kg of ${}^{235}_{92}\text{U}$ undergoes fission reaction.

Solution

235 g of ${}^{235}_{92}\text{U}$ has 6.02×10^{23} atoms. In one gram of ${}^{235}_{92}\text{U}$, the number of atoms is equal to $\frac{6.02 \times 10^{23}}{235} = 2.56 \times 10^{21}$.

So the number of atoms in 1 kg of ${}^{235}_{92}\text{U} = 2.56 \times 10^{21} \times 1000 = 2.56 \times 10^{24}$

Each ${}^{235}_{92}\text{U}$ nucleus releases 200 MeV of energy during the fission. The total energy released by 1kg of ${}^{235}_{92}\text{U}$ is

$$Q = 2.56 \times 10^{24} \times 200 \text{ MeV} = 5.12 \times 10^{26} \text{ MeV}$$

By converting in terms of joules,

$$Q = 5.12 \times 10^{26} \times 1.6 \times 10^{-13} \text{ J} = 8.192 \times 10^{13} \text{ J}.$$

In terms of Kilowatt hour,

$$Q = \frac{8.192 \times 10^{13}}{3.6 \times 10^6} = 2.27 \times 10^7 \text{ kWh}$$

This is enormously large energy which is enough to keep 100 W light bulb operating for 30,000 years. To produce this much energy through chemical reaction, around 20,000 tons of TNT (tri nitro toluene) has to be exploded.

Nuclear reactor:

Nuclear reactor is a system in which the nuclear fission takes place in a self-sustained controlled manner and the energy produced is used either for research purpose or for power generation. The first nuclear reactor was built in the year 1942 at Chicago, USA by physicist Enrico Fermi. The main parts of a nuclear reactor are fuel, moderator and control rods. In addition to this, there is a cooling system which is connected with power generation set up.

Fuel: The fuel is fissionable material, usually uranium or plutonium. Naturally occurring uranium contains only 0.7% of $^{235}_{92}\text{U}$ and 99.3% are only $^{238}_{92}\text{U}$. So the $^{238}_{92}\text{U}$ must be enriched such that it contains at least 2 to 4% of $^{235}_{92}\text{U}$. In addition to this, a neutron source is required to initiate the chain reaction for the first time. A mixture of beryllium

with plutonium or polonium is used as the neutron source. During fission of $^{235}_{92}\text{U}$, only fast neutrons are emitted but the probability of initiating fission by it in another nucleus is very low. Therefore, slow neutrons are preferred for sustained nuclear reactions.

Moderators: The moderator is a material used to convert fast neutrons into slow neutrons. Usually the moderators are chosen in such a way that it must be very light nucleus having mass comparable to that of neutrons. Hence, these light nuclei undergo collision with fast neutrons and the speed of the neutron is reduced (Note that a billiard ball striking a stationary billiard ball of equal mass would itself be stopped but the same billiard ball bounces off almost with same speed when it strikes a heavier mass. This is the reason for using lighter nuclei as moderators). Most of the reactors use water, heavy water (D_2O) and graphite as moderators. The blocks of uranium stacked together with blocks of graphite (the moderator) to form a large pile is shown in the Figure 8.29 (a) & (b).

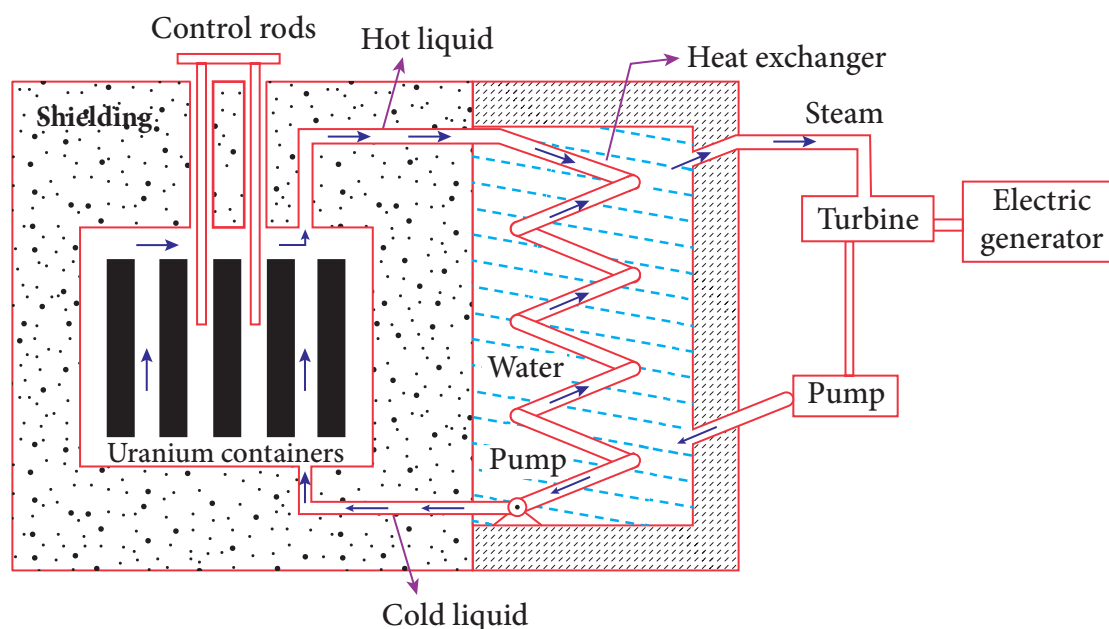

Figure 8.29 (a) Block diagram of Nuclear reactor

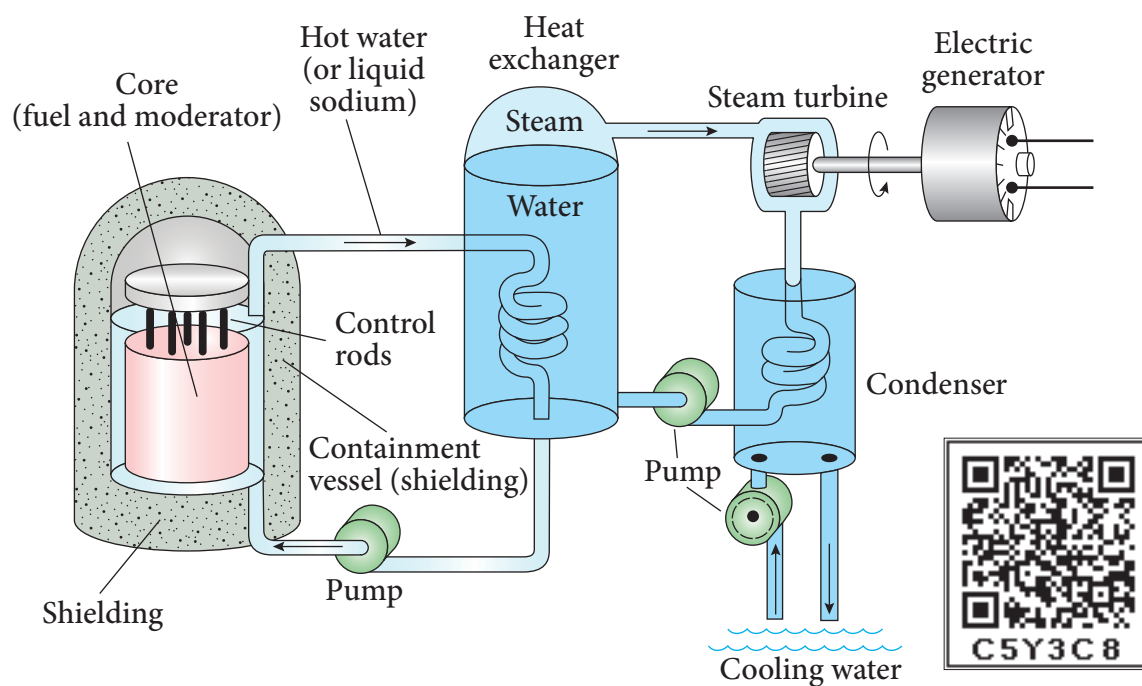

Figure 8.29 (b) Schematic diagram of nuclear reactor

Control rods: The control rods are used to adjust the reaction rate. During each fission, on an average 2.5 neutrons are emitted and in order to have the controlled chain reactions, only one neutron is allowed to cause another fission and the remaining neutrons are absorbed by the control rods.

Usually cadmium or boron acts as control rod material and these rods are inserted into the uranium blocks as shown in the Figure 8.29 (a) and (b). Depending on the insertion depth of control rod into the uranium, the average number of neutrons produced per fission is set to be equal to one or greater than one. If the average number of neutrons produced per fission is equal to one, then reactor is said to be in critical state. In fact, all the nuclear reactors are maintained in critical state by suitable adjustment of control rods. If it is greater than one, then reactor is said to be in super-critical and it may explode sooner or may cause massive destruction.

Shielding: For a protection against harmful radiations, the nuclear reactor is

surrounded by a concrete wall of thickness of about 2 to 2.5 m.

Cooling system: The cooling system removes the heat generated in the reactor core. Ordinary water, heavy water and liquid sodium are used as coolant since they have very high specific heat capacity and have large boiling point under high pressure. This coolant passes through the fuel block and carries away the heat to the steam generator through heat exchanger as shown in Figure 8.29(a) and (b). The steam runs the turbines which produces electricity in power reactors.



Note

India has 22 nuclear reactors in operation. Nuclear reactors are constructed in two places in Tamilnadu, Kalpakkam and Kudankulam. Even though nuclear reactors are aimed to cater to our energy need, in practice nuclear reactors now are able to provide only 2% of energy requirement of India.



8.8

NUCLEAR FUSION

When two or more light nuclei ($A < 20$) combine to form a heavier nucleus, then it is called nuclear fusion. In the nuclear fusion, the mass of the resultant nucleus is less than the sum of the masses of original light nuclei. The mass difference appears as energy. The nuclear fusion never occurs at room temperature unlike nuclear fission. It is because when two light nuclei come closer to combine, it is strongly repelled by the coulomb repulsive force.

To overcome this repulsion, the two light nuclei must have enough kinetic energy to move closer to each other such that the nuclear force becomes effective. This can be achieved if the temperature is very much greater than the value 10^7 K. When the surrounding temperature reaches around 10^7 K, lighter nuclei start fusing to form heavier nuclei and this resulting reaction is called thermonuclear fusion reaction.

Energy generation in stars:

The natural place where nuclear fusion occurs is the core of the stars, since its temperature is of the order of 10^7 K. In fact, the energy generation in every star is only through thermonuclear fusion. Most of the stars including our Sun fuse hydrogen into helium and some stars even fuse helium into heavier elements.

The early stage of a star is in the form of cloud and dust. Due to their own gravitational pull, these clouds fall inward. As a result, its gravitational potential energy is converted to kinetic energy and finally

into heat. When the temperature is high enough to initiate the thermonuclear fusion, they start to release enormous energy which tends to stabilize the star and prevents it from further collapse.

The sun's interior temperature is around 1.5×10^7 K. The sun is converting 6×10^{11} kg hydrogen into helium every second and it has enough hydrogen such that these fusion lasts for another 5 billion years. When the hydrogen is burnt out, the sun will enter into new phase called red giant where helium will fuse to become carbon. During this stage, sun will expand greatly in size and all its planets will be engulfed in it.

According to Hans Bethe, the sun is powered by **proton-proton cycle** of fusion reaction. This cycle consists of three steps and the first two steps are as follows:

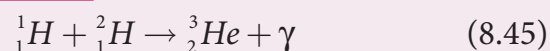
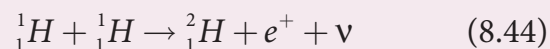

A number of reactions are possible in the third step. But the dominant one is

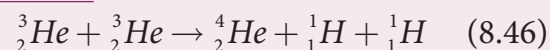

The overall energy production in the above reactions is about 27 MeV. The radiation energy we received from the sun is due to these fusion reactions.

Elementary particles:

An atom has a nucleus surrounded by electrons and nuclei is made up of protons and neutrons. Till 1960s, it was thought that protons, neutrons and electrons are fundamental building blocks of matter. In 1964, physicist Murray Gellman and George

Zweig theoretically proposed that protons and neutrons are not fundamental particles; in fact they are made up of quarks. These quarks are now considered elementary particles of nature. Electrons are fundamental or elementary particles because they are not made up of anything. In the year 1968, the quarks were discovered experimentally by Stanford Linear Accelerator Center (SLAC), USA. There are six quarks namely, up, down, charm, strange, top and bottom and their antiparticles. All these quarks have fractional charges. For example, charge of up quark is $+\frac{2}{3}e$ and that of down quark is $-\frac{1}{3}e$.

According to quark model, proton is made up of two up quarks and one down quark and neutron is made up of one up quark and two down quarks as shown in the Figure 8.30.

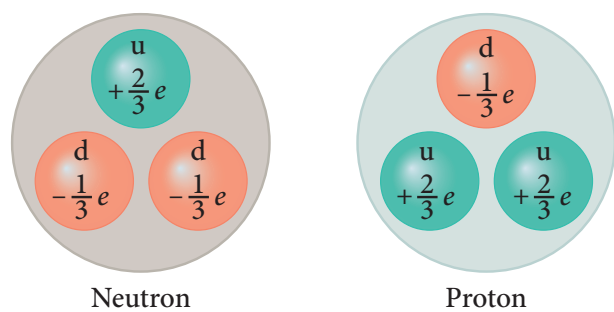

Figure 8.30 Constituents of nucleons

The study of elementary particles is called particle physics and it is an active area of research even now. Till date, more than 20 Nobel prizes have been awarded in the field of particle physics.

Fundamental forces of nature:

It is known that there exists gravitational force between two masses and it is universal

in nature. Our planets are bound to the sun through gravitational force of the sun. In volume 1, we have learnt that between two charges there exists electromagnetic force and it plays major role in most of our day-to-day events. In this unit, we have learnt that between two nucleons, there exists a strong nuclear force and this force is responsible for stability of the nucleus. In addition to these three forces, there exists another fundamental force of nature called the weak force. This weak force is even shorter in range than nuclear force. This force plays an important role in beta decay and energy production of stars. During the fusion of hydrogen into helium in sun, neutrinos and enormous radiations are produced through weak force. The detailed mechanism of weak force is beyond the scope of this book and for further reading, appropriate books can be referred.

Gravitational, electromagnetic, strong and weak forces are called fundamental forces of nature. It is very interesting to realize that, even for our day-to-day life, we require these four fundamental forces. To put it in simple words: We are in the Earth because of Earth's gravitational attraction on our body. We are standing on the surface of the earth because of the electromagnetic force between atoms of the surface of the earth with atoms in our foot. The atoms in our body are stable because of strong nuclear force. Finally, the lives of species in the earth depend on the solar energy from the sun and it is due to weak force which plays vital role during nuclear fusion reactions going on in the core of the sun.

SUMMARY

- A device used to study the conduction of electricity through gases is known as gas discharge tube
- Charge per unit mass is known as specific charge or normalized charge, and it is independent of gas used and also nature of electrodes used
- The minimum distance between alpha particle and centre of the nucleus just before it gets reflected back by 180° is defined as distance of closest approach r_0
- The impact parameter (b) (see Figure 8.12) is defined as the perpendicular distance between the centre of the gold nucleus and the direction of velocity vector of alpha particle when it is at a large distance.
- According to Bohr atom model, angular momentum is quantized.
- The radius of the orbit in Bohr atom model is $r_n = a_0 \frac{n^2}{Z}$
- The radius of first orbit is $a_0 = \frac{\epsilon_0 h^2}{\pi m e^2} = 0.529 \text{ \AA}$ also known as Bohr radius
- The velocity of electron in n^{th} orbit is $v_n = \frac{h}{2\pi m a_0} \frac{Z}{n}$
- The fine structure constant is $\alpha = \frac{1}{137}$ which is a dimensionless constant
- The total energy of electron in the n^{th} orbit is $E_n = -\frac{m e^4 Z^2}{8 \epsilon_0^2 h^2 n^2} = -13.6 \frac{1}{n^2} eV$
- The energy required to excite an electron from the lower energy state to any higher energy state is known as excitation energy and corresponding potential supplied is known as excitation potential.
- The minimum energy required to remove an electron from an atom which is in ground state is known as ionization energy.
- The potential difference through which an electron should be accelerated to get ionization energy is known as ionization potential.
- The wavelength of spectral lines of Lyman series lies in ultra-violet region
- The wavelength of spectral lines of Balmer series lies in visible region while those of Paschen and Brackett series lie in infra-red region
- The nucleus of element X having atomic number Z and mass number A is represented by ${}^A_Z X$
- The radius of nucleus ($Z > 10$) of mass number A is given by $R = R_0 A^{1/3}$ where $R_0 = 1.2 F$
- The density of nucleus $\rho = 2.3 \times 10^{17} \text{ kg m}^{-3}$
- If M , m_p and m_n are masses of a nucleus (${}^A_Z X$), proton and neutron respectively, then the mass defect is $\Delta m = (Zm_p + Nm_n) - M$
- The binding energy of nucleus $B.E = (Zm_p + Nm_n - M)c^2$
- The binding energy per nucleon is maximum for iron which is 8.8 MeV.



- Alpha decay: ${}^A_Z X \rightarrow {}^{A-4}_{Z-2} Y + {}^4_2 He$
- β^- decay: ${}^A_Z X \rightarrow {}^A_{Z+1} Y + e^- + \bar{\nu}$
- β^+ decay: ${}^A_Z X \rightarrow {}^A_{Z-1} Y + e^+ + \nu$
- Gamma decay: ${}^A_Z X^* \rightarrow {}^A_Z X + \gamma$
- Law of radioactive decay: $N = N_0 e^{-\lambda t}$
- In general, after n half lives, the number of nuclei undecayed is $N = \left(\frac{1}{2}\right)^n N_0$
- The relation between half-life and decay constant $T_{1/2} = \frac{\ln 2}{\lambda}$
- If a heavier nucleus decays into lighter nuclei, it is called nuclear fission
- If two lighter nuclei fuse to heavier nuclei, it is called nuclear fusion
- In nuclear reactors, the nuclear chain reaction is controlled. In stars, the energy generation is through nuclear fusion.

CONCEPT MAP

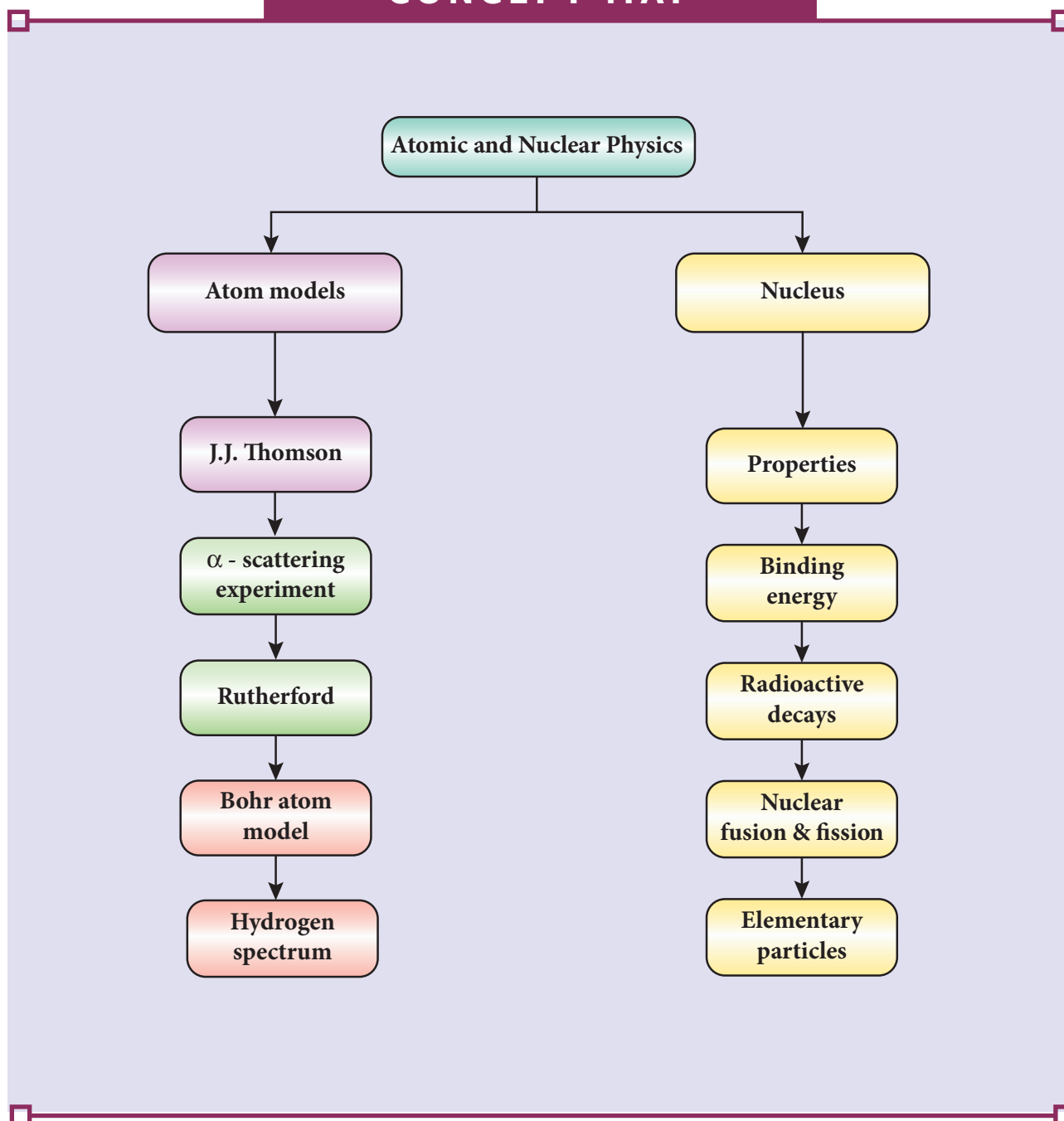



I Multiple Choice Questions

- Suppose an alpha particle accelerated by a potential of V volt is allowed to collide with a nucleus whose atomic number is Z , then the distance of closest approach of alpha particle to the nucleus is
 - $14.4 \frac{Z}{V} \text{ \AA}$
 - $14.4 \frac{V}{Z} \text{ \AA}$
 - $1.44 \frac{Z}{V} \text{ \AA}$
 - $1.44 \frac{V}{Z} \text{ \AA}$
- In a hydrogen atom, the electron revolving in the fourth orbit, has angular momentum equal to
 - h
 - $\frac{h}{\pi}$
 - $\frac{4h}{\pi}$
 - $\frac{2h}{\pi}$
- Atomic number of H-like atom with ionization potential 122.4 V for $n = 1$ is
 - 1
 - 2
 - 3
 - 4
- The ratio between the first three orbits of hydrogen atom is
 - 1:2:3
 - 2:4:6
 - 1:4:9
 - 1:3:5
- The charge of cathode rays is
 - positive
 - negative
 - neutral
 - not defined
- In J.J. Thomson e/m experiment, a beam of electron is replaced by that of muons (particle with same charge as that of electrons but mass 208 times that of electrons). No deflection condition is achieved only if
 - B is increased by 208 times
 - B is decreased by 208 times
 - B is increased by 14.4 times
 - B is decreased by 14.4 times
- The ratio of the wavelengths for the transition from $n = 2$ to $n = 1$ in Li^{++} , He^+ and H is
 - 1: 2: 3
 - 1: 4: 9
 - 3:2:1
 - 4: 9: 36
- The electric potential between a proton and an electron is given by $V = V_0 \ln \left(\frac{r}{r_0} \right)$, where r_0 is a constant. Assume that Bohr atom model is applicable to potential, then variation of radius of n^{th} orbit r_n with the principal quantum number n is
 - $r_n \propto \frac{1}{n}$
 - $r_n \propto n$
 - $r_n \propto \frac{1}{n^2}$
 - $r_n \propto n^2$
- If the nuclear radius of ^{27}Al is 3.6 fermi, the approximate nuclear radius of ^{64}Cu is
 - 2.4
 - 1.2
 - 4.8
 - 3.6
- The nucleus is approximately spherical in shape. Then the surface area of nucleus having mass number A varies as
 - $A^{2/3}$
 - $A^{4/3}$
 - $A^{1/3}$
 - $A^{5/3}$
- The mass of a 7_3Li nucleus is 0.042 u less than the sum of the masses of all its nucleons. The binding energy per nucleon of 7_3Li nucleus is nearly
 - 46 MeV
 - 5.6 MeV
 - 3.9 MeV
 - 23 MeV



12. M_p denotes the mass of the proton and M_n denotes mass of a neutron. A given nucleus of binding energy B , contains Z protons and N neutrons. The mass $M(N,Z)$ of the nucleus is given by (where c is the speed of light)

- (a) $M(N,Z) = NM_n + ZM_p - Bc^2$
 (b) $M(N,Z) = NM_n + ZM_p + Bc^2$
 (c) $M(N,Z) = NM_n + ZM_p - B/c^2$
 (d) $M(N,Z) = NM_n + ZM_p + B/c^2$

13. A radioactive nucleus (initial mass number A and atomic number Z) emits 2α and 2 positrons. The ratio of number of neutrons to that of proton in the final nucleus will be

- (a) $\frac{A-Z-4}{Z-2}$ (b) $\frac{A-Z-2}{Z-6}$
 (c) $\frac{A-Z-4}{Z-6}$ (d) $\frac{A-Z-12}{Z-4}$

14. The half-life period of a radioactive element A is same as the mean life time of another radioactive element B. Initially both have the same number of atoms. Then

- (a) A and B have the same decay rate initially
 (b) A and B decay at the same rate always
 (c) B will decay at faster rate than A
 (d) A will decay at faster rate than B.

15. A system consists of N_0 nucleus at $t=0$. The number of nuclei remaining after half of a half-life (that is, at time

$$t = \frac{1}{2} T_{\frac{1}{2}})$$

- (a) $\frac{N_0}{2}$ (b) $\frac{N_0}{\sqrt{2}}$
 (c) $\frac{N_0}{4}$ (d) $\frac{N_0}{8}$

Answers

- 1) c 2) d 3) c 4) c 5) b
 6) c 7) d 8) b 9) c 10) A
 11) b 12) c 13) b 14) c 15) b

II Short answer questions

1. What are cathode rays?
2. Write the properties of cathode rays.
3. Give the results of Rutherford alpha scattering experiment.
4. Write down the postulates of Bohr atom model.
5. What is meant by excitation energy.
6. Define the ionization energy and ionization potential.
7. Write down the draw backs of Bohr atom model.
8. What is distance of closest approach?
9. Define impact parameter.
10. Write a general notation of nucleus of element X. What each term denotes?
11. What is isotope? Give an example.
12. What is isotone? Give an example.
13. What is isobar? Give an example.
14. Define atomic mass unit u .
15. Show that nuclear density is almost constant for nuclei with $Z > 10$.
16. What is mass defect?
17. What is binding energy of a nucleus? Give its expression.
18. Calculate the energy equivalent of 1 atomic mass unit.
19. Give the physical meaning of binding energy per nucleon.
20. What is meant by radioactivity?

21. Give the symbolic representation of alpha decay, beta decay and gamma decay.
22. In alpha decay, why the unstable nucleus emits ${}^4_2\text{He}$ nucleus? Why it does not emit four separate nucleons?
23. What is mean life of nucleus? Give the expression.
24. What is half-life of nucleus? Give the expression.
25. What is meant by activity or decay rate? Give its unit.
26. Define curie.
27. What are the constituent particles of neutron and proton?
9. Discuss the gamma decay process with example.
10. Obtain the law of radioactivity.
11. Discuss the properties of neutrino and its role in beta decay.
12. Explain the idea of carbon dating.
13. Discuss the process of nuclear fission and its properties.
14. Discuss the process of nuclear fusion and how energy is generated in stars?
15. Describe the working of nuclear reactor with a block diagram.
16. Explain in detail the four fundamental forces.
17. Briefly explain the elementary particles of nature.

III Long answer questions

1. Explain the J.J. Thomson experiment to determine the specific charge of electron.
2. Discuss the Millikan's oil drop experiment to determine the charge of an electron.
3. Derive the energy expression for hydrogen atom using Bohr atom model.
4. Discuss the spectral series of hydrogen atom.
5. Explain the variation of average binding energy with the mass number by graph and discuss its features.
6. Explain in detail the nuclear force.
7. Discuss the alpha decay process with example.
8. Discuss the beta decay process with examples.

Exercises

1. Consider two hydrogen atoms H_A and H_B in ground state. Assume that hydrogen atom H_A is at rest and hydrogen atom H_B is moving with a speed and make head-on collide on the stationary hydrogen atom H_A . After the strike, both of them move together. What is minimum value of the kinetic energy of the moving hydrogen atom H_B , such that any one of the hydrogen atoms reaches one of the excitation state.

[Ans: 20.4 eV]

2. In the Bohr atom model, the frequency of transitions is given by the following expression

$$\nu = Rc \left(\frac{1}{n^2} - \frac{1}{m^2} \right), \text{ where } n < m,$$

Consider the following transitions:

Transitions	$m \rightarrow n$
1	$3 \rightarrow 2$
2	$2 \rightarrow 1$
3	$3 \rightarrow 1$

Show that the frequency of these transitions obey sum rule (which is known as Ritz combination principle)

$$[\text{Ans: } \nu_{3 \rightarrow 2} + \nu_{2 \rightarrow 1} = \nu_{3 \rightarrow 1}]$$

3. (a) A hydrogen atom is excited by radiation of wavelength 97.5 nm. Find the principal quantum number of the excited state.

(b) Show that the total number of lines in emission spectrum is $\frac{n(n-1)}{2}$ and compute the total number of possible lines in emission spectrum.

[Ans: (a) $n=4$ (b) 6 possible transitions]

4. Calculate the radius of the earth if the density of the earth is equal to the density of the nucleus. [mass of earth $5.97 \times 10^{24} \text{ kg}$].

[Ans: 180 m]

5. Calculate the mass defect and the binding energy per nucleon of the $^{108}_{47}\text{Ag}$ nucleus. [atomic mass of Ag = 107.905949]

$$\text{Ans: } \left[\begin{array}{l} \Delta m = 0.990391u \text{ and} \\ \overline{B.E} = 8.5 \text{ MeV} / A \end{array} \right]$$

6. Half lives of two radioactive elements A and B are 20 minutes and 40 minutes respectively. Initially, the samples have equal number of nuclei. Calculate the

ratio of decayed numbers of A and B nuclei after 80 minutes.

[Ans: 5:4]

7. On your birthday, you measure the activity of the sample ^{210}Bi which has a half-life of 5.01 days. The initial activity that you measure is $1 \mu\text{Ci}$. (a) What is the approximate activity of the sample on your next birthday? Calculate (b) the decay constant (c) the mean life (d) initial number of atoms.

[Ans: (a) $10^{-22} \mu\text{Ci}$ (b) $1.6 \times 10^{-6} \text{ s}^{-1}$

(c) 7.24 days (d) 2.31×10^{10}]

8. Calculate the time required for 60% of a sample of radon undergo decay. Given $T_{1/2}$ of radon = 3.8 days

[Ans: 5.022 days]

9. Assuming that energy released by the fission of a single $^{235}_{92}\text{U}$ nucleus is 200 MeV, calculate the number of fissions per second required to produce 1 watt power.

[Ans: 3.125×10^{10}]

10. Show that the mass of radium ($^{226}_{88}\text{Ra}$) with an activity of 1 curie is almost a gram. Given $T_{1/2} = 1600$ years.

11. Characol pieces of tree is found from an archeological site. The carbon-14 content of this characol is only 17.5% that of equivalent sample of carbon from a living tree. What is the age of tree?

[Ans: $1.44 \times 10^4 \text{ yr}$]



BOOKS FOR REFERENCE

1. Introduction to Modern Physics, H.S. Mani and G.K. Mehta, East-West Press, New Delhi
2. Concepts of Modern Physics, Arthur Beiser, McGraw Hill, 6th edition
3. Concepts of Physics – H. C. Verma, Volume 2, Bharati Bhawan Publisher
4. Fundamentals of Physics, Halliday, Resnick and Walker, Wiley Publishers, 10th edition
5. Physics for scientist and engineers with modern physics, Serway and Jewett, Brook/Coole publishers, 8th edition
6. Physics for scientist and engineers with modern physics, Paul Tipler and Gene Mosca, Sixth edition, W.H.Freeman and Company



ICT CORNER

Atomic and Nuclear physics

In this activity you will be able to (i) experimentally demonstrate the concept of Millikan's oil drop experiment (ii) find the terminal velocity of the drop and (iii) find the charge on a drop.

Topic: Millikan's oil drop experiment

STEPS:

- Open the browser and type "vlab.amrita.edu" in the address bar.
- Click 'Physical Sciences' tab. Then click 'Modern Physics Virtual Lab' and then click 'Millikan's oil drop experiment'. Go to "simulator" tab to do the experiment.
- Click on 'START' button. Click on Combo box to choose the oil.
- Click 'START' button of stop watch and notice the time taken t_1 by a drop, to travel distance l_1 between any two points. Calculate the terminal velocity $v_1 = \frac{l_1}{t_1}$
- Click 'Voltage On' to suspend the same oil drop in air, which is the balancing voltage V .
- Click the 'X Ray ON' button and notice the time taken t_2 by same drop to travel distance l_2 between any two points. Calculate the terminal velocity $v_2 = \frac{l_2}{t_2}$
- Charge of drop is calculated using the equation $q = \frac{6\pi\eta r(v_1 + v_2)d}{V}$. r -radius of oil drop (can be measure using telescope), η -viscosity of air ($1.81 \times 10^{-5} \text{ kgm}^{-1}\text{s}^{-1}$), d is the distance between the plates.

Step1

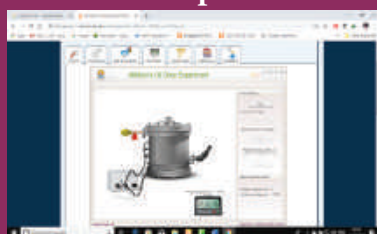

Step2

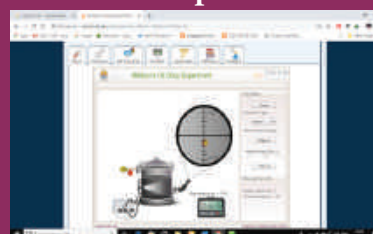

Step3

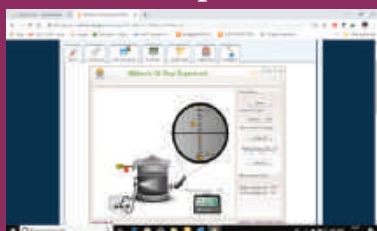

Step4

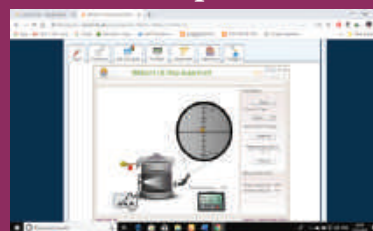

Note:

1. One time sign up is needed to do simulation. Then login using that username and password.
2. Install flash player in your browser if it is not there.

URL:

<http://vlab.amrita.edu/index.php?sub=1&brch=195&sim=357&cnt=4>

- * Pictures are indicative only.
- * If browser requires, allow **Flash Player** or **Java Script** to load the page.



B263_12_PHYSICS_EM

UNIT 9

SEMICONDUCTOR ELECTRONICS

Electronics is clearly the winner of the day
– John Ford.

LEARNING OBJECTIVES

In this unit, the students are exposed to,

- Energy band diagram in semiconductors
- Types of semiconductors
- Formation of p-n junction diode and its V-I characteristics
- Rectification process
- Special purpose diodes
- Transistors and their immediate applications
- Digital and analog signals
- Logic gates
- Boolean algebra
- De Morgan's theorem



9.1

INTRODUCTION

Electronics has become a part of our daily life. All gadgets like mobile phones, computers, televisions, music systems etc work on the electronic principles. Electronic circuits are used to perform various operations in devices like air conditioners, microwave oven, dish washers and washing machines. Besides this, its applications are widespread in all fields like communication systems, medical diagnosis and treatments and even handling money through ATMs.

Evolution of Electronics:

The history of electronics began with the invention of vacuum diode by J.A. Fleming

in 1897. This was followed by a vacuum triode implemented by Lee De Forest to control electrical signals. This led to the introduction of tetrode and pentode tubes.

Subsequently, the transistor era began with the invention of bipolar junction transistor by Bardeen, Brattain and Shockley in 1948 for which Nobel prize was awarded in 1956. The emergence of Germanium and Silicon semiconductor materials made this transistor gain popularity, in turn its application in different electronic circuits.

The following years witnessed the invention of the integrated circuits (ICs) that helped to integrate the entire electronic circuit on a single chip which is small in size and cost-effective. Since 1958 ICs capable

of holding several thousand electronic components on a single chip such as small-scale, medium-scale, large-scale, and very-large scale integration started coming into existence. Digital integrated circuits became another robust IC development that enhanced the architecture of computers. All these radical changes led to the introduction of microprocessor in 1969 by Intel.

The electronics revolution, in due course of time, accelerated the computer revolution. Now the world is on its way towards small particles of nano-size, far too small to see. This helps in the miniaturization to an unimaginable size. A room-size computer during its invention has now emerged as a laptop, palmtop, iPad, etc. In the recent past, IBM revealed the smallest computer whose size is comparable with the tip of the rice grain, measuring just 0.33 mm on each side.

Electronics is the branch of physics incorporated with technology towards the design of circuits using transistors and microchips. It depicts the behaviour and movement of electrons and holes in a semiconductor, electrons and ions in vacuum, or gas. Electronics deals with electrical circuits that involve active components such as transistors, diodes, integrated circuits, and sensors, associated with the passive components like resistors, inductors, capacitors, and transformers.

This chapter deals with semiconductor devices like p-n junction diodes, bipolar junction transistors and logic circuits.



Note Passive Components: components that cannot generate power in a circuit.

Active components: components that can generate power in a circuit.



(a)



(b)



(c)



(d)



(e)

Figure: 9.1 Evolution of computers (a) one of the world's first computers (b) desktop computer (c) laptop computer (d) palmtop computer (e) Thinnest computer revealed by IBM



The world's first computer 'ENIAC' was invented by J. Presper Eckert and John Mauchly at the University of Pennsylvania. The construction work started in 1943 and got over in 1946. It occupied an area of around 1800 square feet. It had 18,000 vacuum tubes and it weighed around 50 tons.

9.1.1 Energy band diagram of solids

In an isolated atom, the electronic energy levels are widely separated and are far apart and the energy of the electron is decided by the

orbit in which it revolves around the nucleus. However, in the case of a solid, the atoms are closely spaced and hence the electrons in the outermost energy levels of nearby atoms influence each other. This changes the nature of the electron motion in a solid from that of an isolated atom to a large extent.

The valence electrons in an atom are responsible for the bonding nature. Let us consider an atom with one electron in the outermost orbit. It means that the number of valence electrons is one. When two such atoms are brought close to each other, the valence orbitals are split into two. Similarly the unoccupied orbitals of each atom will also split into two. The electrons have the choice of choosing any one of the orbitals as the energy of both the orbitals is the same. When the third atom of the same element is brought to this system, the valence orbitals of all the three atoms are split into three. The unoccupied orbitals also will split into three.

In reality, a solid is made up of millions of atoms. When millions of atoms are brought close to each other, the valence orbitals and the unoccupied orbitals are split according to the number of atoms. In this case, the energy levels will be closely spaced and will be difficult to differentiate the orbitals of one atom from the other and they look like a band as shown in Figure 9.2. **This band**

of very large number of closely spaced energy levels in a very small energy range is known as energy band.

The energy band formed due to the valence orbitals is called valence band and that formed due to the unoccupied orbitals to which electrons can jump when energised is called the conduction band. The energy gap between the valence band and the conduction band is called forbidden energy gap. Electrons cannot exist in the forbidden energy gap.

The representation of the valence band and conduction band is shown in Figure 9.2(a). E_v represents the maximum energy of the valence band and E_c represents minimum energy of the conduction band. The forbidden energy gap, $E_g = E_c - E_v$. The kinetic energy of the electron increases from bottom to top (near the nucleus to the farthest) and the potential energy decreases indicating that the electrons in the orbitals closer to the nucleus are bound with large potential energy. Hence, the electrons closer to nucleus require a lot of energy to be excited. The electrons in the valence band are less bound to the nucleus and can be easily excited.

Note The energy levels of the orbiting electrons are measured in electron volts, (eV).

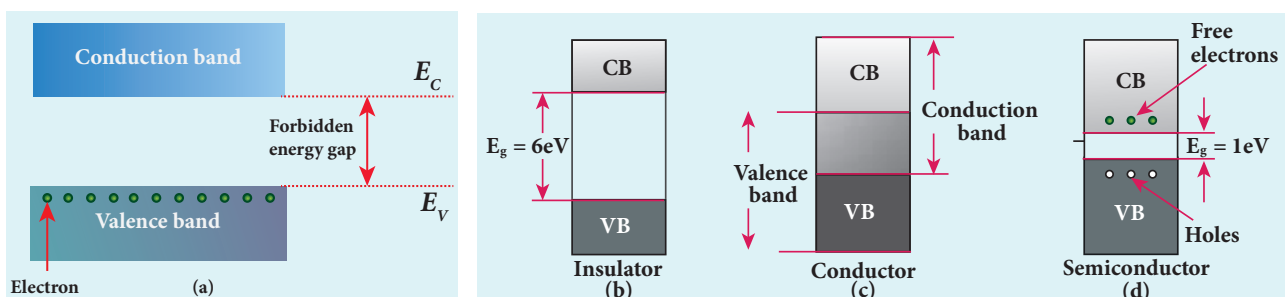

Figure: 9.2 (a) Schematic representation of valence band, conduction band, and forbidden energy gap. Energy band structure of (b) Insulator (c) Conductor (d) Semiconductor

9.1.2 Classification of materials

The classification of solids into insulators, metals, and semiconductors can be explained with the help of the energy band diagram.

9.1.2.1 Insulators

The energy band structure of insulators is shown in Figure 9.2(b). The valence band and the conduction band are separated by a large energy gap. The forbidden energy gap is approximately 6 eV in insulators. The gap is very large that electrons from valence band cannot move into conduction band even on the application of strong external electric field or the increase in temperature. Therefore, the electrical conduction is not possible as the free electrons are almost nil and hence these materials are called insulators. Its resistivity is in the range of 10^{11} – 10^{19} Ωm .

9.1.2.2 Conductors

In conductors, the valence band and conduction band overlap as shown in Figure 9.2(c). Hence, electrons can move freely into the conduction band which results in a large number of free electrons in the conduction band. Therefore, conduction becomes possible even at low temperatures. The application of electric field provides sufficient energy to the electrons to drift in a particular direction to constitute a current. For conductors, the resistivity value lies between 10^{-2} and 10^{-8} Ωm .

9.1.2.3 Semiconductors

In semiconductors, there exists a narrow forbidden energy gap ($E_g < 3\text{eV}$) between the valence band and the conduction band. At a finite temperature, thermal agitations

in the solid can break the covalent bond between the atoms (covalent bond is formed due to the sharing of electrons to attain stable electronic configuration). This releases some electrons from valence band to conduction band. Since free electrons are small in number, the conductivity of the semiconductors is not as high as that of the conductors. The resistivity value of semiconductors is from 10^{-5} to 10^6 Ωm .



Note

In semiconductors, electrons in the valence band are bound electrons which cannot move. Hence, they cannot contribute for conduction.

When the temperature is increased further, more number of electrons is promoted to the conduction band and increases the conduction. Thus, we can say that the electrical conduction increases with the increase in temperature. In other words, resistance decreases with increase in temperature. Hence, semiconductors are said to have negative temperature coefficient of resistance. The most important elemental semiconductor materials are Silicon (Si) and Germanium (Ge). The forbidden energy gaps for Si and Ge at room temperature are 1.1 eV and 0.7 eV respectively.

9.2

TYPES OF SEMICONDUCTORS

9.2.1 Intrinsic semiconductors

A semiconductor in its pure form without impurity is called an intrinsic semiconductor. Here, impurity means any

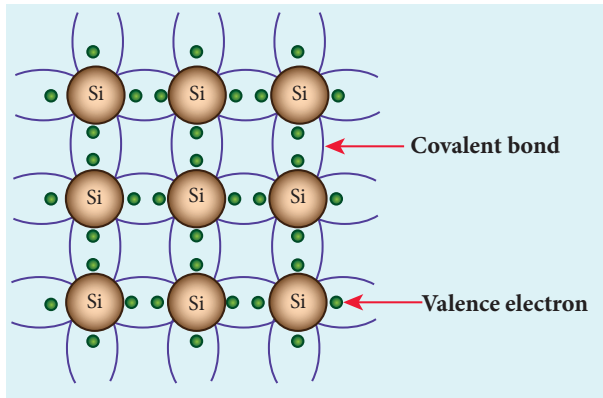

(a)

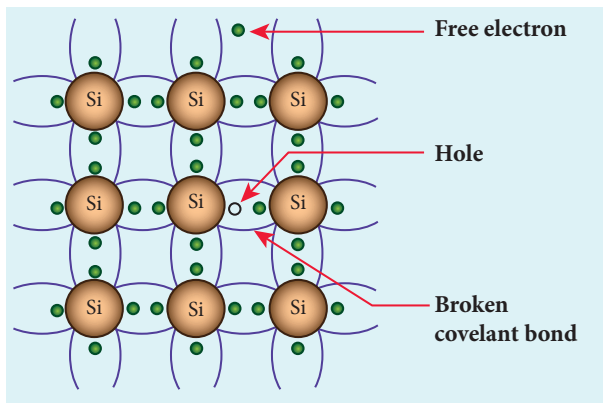

(b)

Figure: 9.3 (a) Two dimensional crystal lattice of Silicon (b) The presence of free electron, hole, and broken covalent bond in the intrinsic Silicon crystal.

other atom in the crystal lattice. The Silicon lattice is shown in Figure 9.3(a). Each Silicon atom has four electrons in the outermost orbit and is covalently bonded with the neighbouring atoms to form the lattice. The band diagram for this case is shown in Figure 9.4(a).

A small increase in temperature is sufficient enough to break some of the covalent bonds and release the electrons free from the lattice as shown in Figure 9.3(b). As a result, some states in the valence band become empty and the same number of states in the conduction band will be occupied as shown in Figure 9.4(b). The vacancies produced in the valence band are called holes. As the holes are deficiency of electrons, they are treated to possess positive charges. Hence, electrons and holes are the two charge carriers in semiconductors.

In intrinsic semiconductors, the number of electrons in the conduction band is equal to the number of holes in the valence band. The conduction is due to the electrons in the

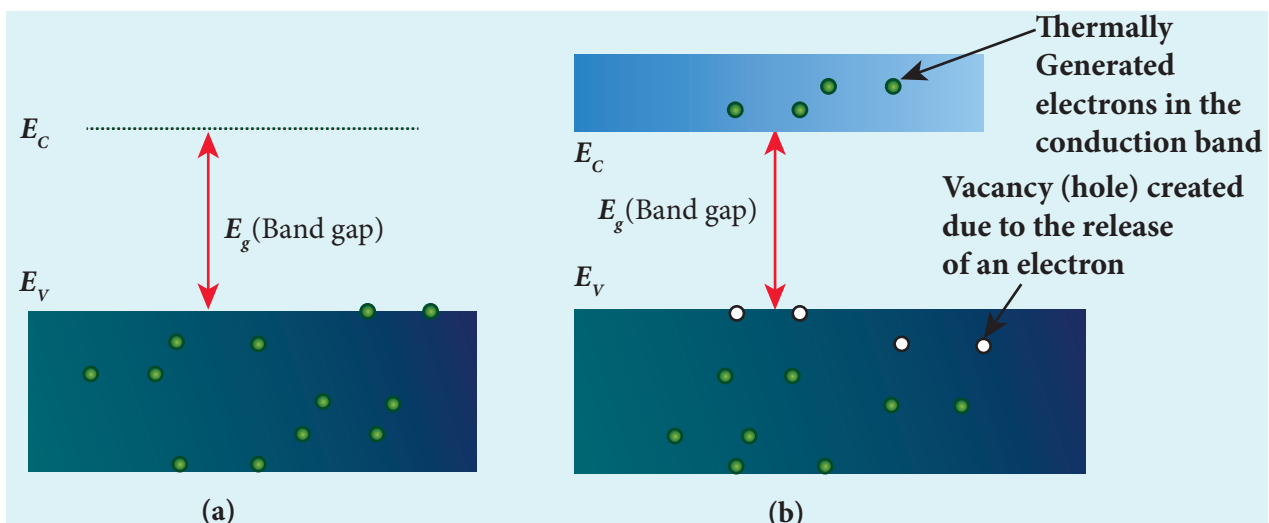

Figure: 9.4 (a) Valence band and conduction band of intrinsic semiconductor. (b) Presence of thermally generated electrons in the conduction band and vacancy created due to the shift of electron from valence band to conduction band at room temperature.



conduction band and holes in the valence band. These currents are represented as I_e and I_h respectively.



Note Definition of a hole: When an electron is excited, covalent bond is broken. Now octet rule will not be satisfied. Thus each excited electron leaves a vacancy to complete bonding. This 'deficiency' of electron is termed as a 'hole'

The total current (I) is always the sum of the electron current (I_e) and the hole current (I_h). $I = I_e + I_h$

An intrinsic semiconductor behaves like an insulator at 0 K. The increase in temperature increases the number of charge carriers (electrons and holes). The schematic diagram of the intrinsic semiconductor in band diagram is shown in Figure 9.4(b). The intrinsic carrier concentration is the number electron in the conduction band or the number of holes in the valence band in an intrinsic semiconductor.

9.2.2 Extrinsic semiconductors

The carrier concentration in an intrinsic semiconductor is not sufficient enough to develop efficient electronic devices. Another way of increasing the carrier concentration in an intrinsic semiconductor is by adding impurity atoms. **The process of adding impurities to the intrinsic semiconductor is called doping.** It increases the concentration of charge carriers (electrons and holes) in the semiconductor and in turn, its electrical conductivity. The impurity atoms are called dopants and its order is approximately 100 ppm (parts per million).

9.2.2.1 n-type semiconductor

An n-type semiconductor is obtained by doping a pure Germanium (or Silicon) crystal with a dopant from group V pentavalent elements like Phosphorus, Arsenic, and Antimony as shown in Figure 9.5(a). The dopant has five valence electrons while the Germanium atom has four valence electrons. During the process of doping, a few of the Germanium atoms are replaced by the group V dopants. Four of the five valence electrons of the impurity atom are bound with the 4 valence electrons of the neighbouring replaced Germanium atom. The fifth valence electron of the impurity atom will be loosely attached with the nucleus as it has not formed the covalent bond.

The energy level of the loosely attached fifth electron from the dopant is found just below the conduction band edge and

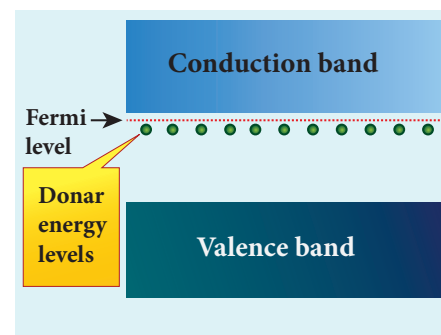
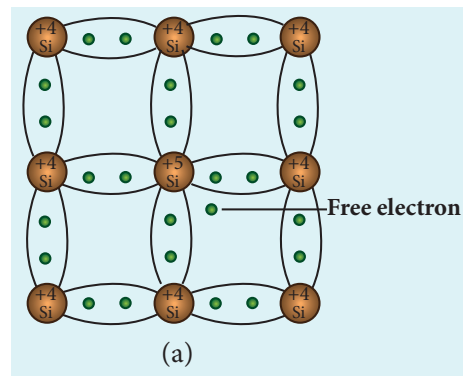

Figure 9.5 n-type extrinsic semiconductor: (a) Free electron which is loosely attached to the lattice (b) Representation of donor energy level.

is called the donor energy level as shown in Figure 9.5(b). At room temperature, these electrons can easily move to the conduction band with the absorption of thermal energy. It is shown in the Figure 9.6. Besides, an external electric field also can set free the loosely bound electrons and lead to conduction.

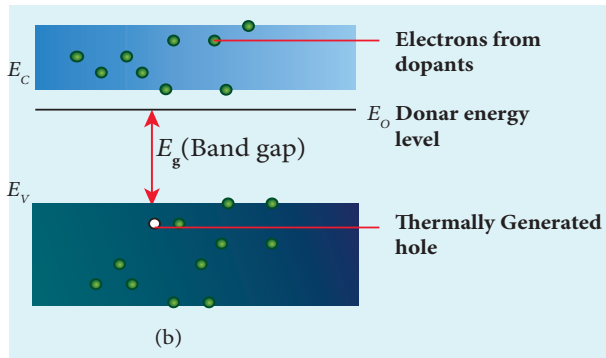

Figure 9.6 Thermally generated hole in the valence band and the free electrons generated by the dopants in the conduction band (n-type semiconductor).

It is important to note that the energy required for an electron to jump from the valence band to the conduction band (E_g) in an intrinsic semiconductor is 0.7 eV for Ge and 1.1 eV for Si, while the energy required to set free a donor electron is only 0.01 eV for Ge and 0.05 eV for Si.

The group V pentavalent impurity atoms donate electrons to the conduction band and are called donor impurities. Therefore, each impurity atom provides one extra electron to the conduction band in addition to the thermally generated electrons. These thermally generated electrons leave holes in valence band. Hence, the majority carriers of current in an n-type semiconductor are electrons and the minority carriers are holes. Such a semiconductor doped with a pentavalent impurity is called an n-type semiconductor.

9.2.2.2 p-type semiconductor

Here, a trivalent atom from group III elements such as Boron, Aluminium, Gallium and Indium is added to the Germanium or Silicon substrate. The dopant with three valence electrons are bound with the neighbouring Germanium atom as shown in Figure 9.7(a). As Germanium atom has four valence electrons, one electron position of the dopant in the Germanium crystal lattice will remain vacant. The missing electron position in the covalent bond is denoted as a hole.

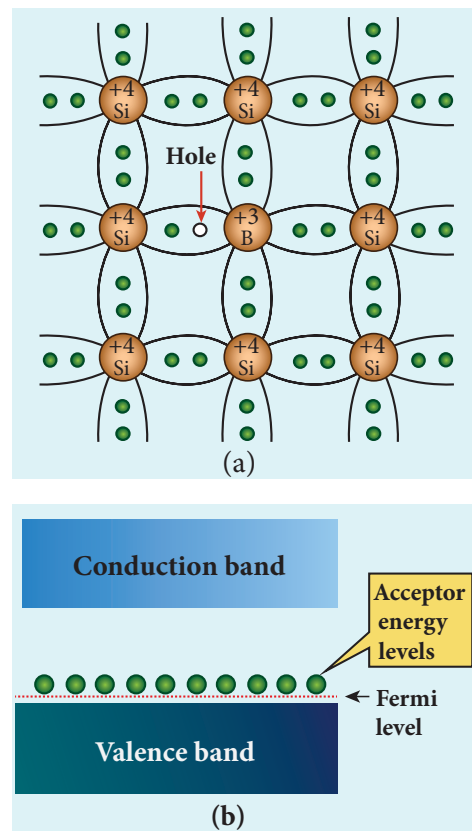

Figure 9.7 P-type extrinsic semiconductor (a) Hole generated by the dopant (b) Representation of acceptor energy level.

To make complete covalent bonding with all four neighbouring atoms, the dopant is in need of one more electron. These dopants can accept electrons from the neighbouring atoms. Therefore, this impurity is called an acceptor impurity. The energy level of the hole created by each

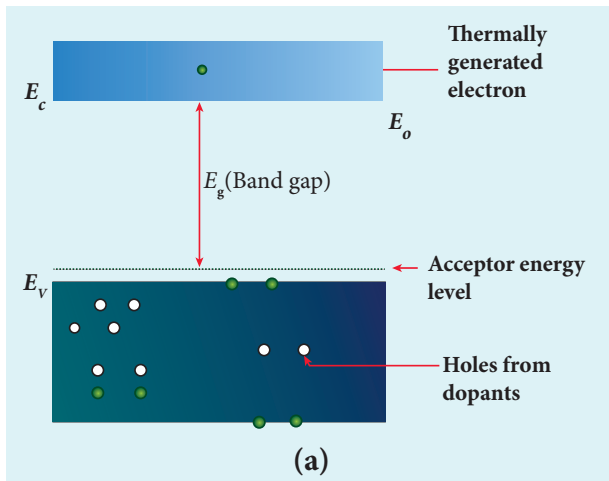

Figure 9.8 Thermally generated electron in the conduction band and the holes generated by the dopants in the valence band (p-type semiconductor).

impurity atom is just above the valence band and is called the acceptor energy level, as shown in Figure 9.7(b).

For each acceptor atom, there will be a hole in the valence band in addition to the thermally generated holes. In such an extrinsic semiconductor, holes are the majority carriers and thermally generated electrons are minority carriers as shown in Figure 9.8. The semiconductor thus formed is called a p-type semiconductor.



The n-type and p-type semiconductor are neutral as we are topping neutral atoms to the intrinsic semiconductors.

9.3 DIODES

9.3.1 P-N Junction formation

9.3.1.1 Formation of depletion layer

A *p-n* junction is formed by joining *n*-type and *p*-type semiconductor materials

as shown in Figure 9.9(a). Since the *n*-region has a high electron concentration and the *p*-region a high hole concentration, electrons diffuse from the *n*-side to the *p*-side. This causes *diffusion current* which exists due to the concentration difference of electrons. The electrons diffusing into the *p*-region may occupy holes in that region and make it negative. The holes left behind by these electrons in the *n*-side are equivalent to the diffusion of holes from the *p*-side to the *n*-side. If the electrons and holes were not charged, this diffusion process would continue until the concentration of electrons

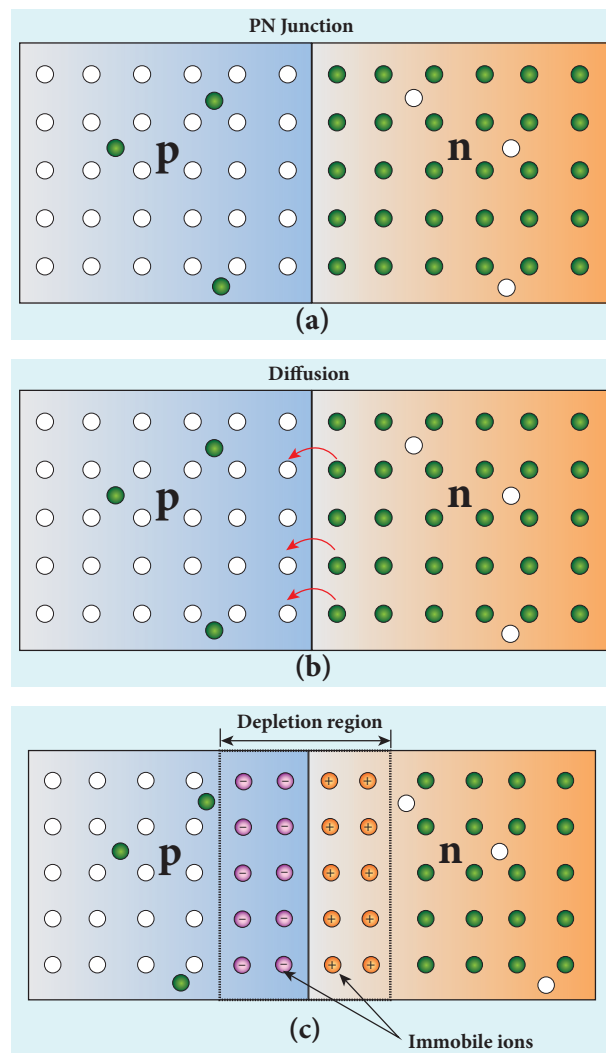

Figure: 9.9 (a) P-N junction (b) Diffusion of electrons across the junction (c) Presence of immobile ions in the depletion region

and holes on the two sides were the same, as happens if two gasses come into contact with each other.

But, in a p-n junction, when the electrons and holes move to the other side of the junction, they leave behind exposed charges on dopant atom sites, which are fixed in the crystal lattice and are unable to move. On the *n*-side, positive ion cores are exposed and on the *p*-side, negative ion cores are exposed as shown in Figure 9.9(b). An electric field E forms between the positive ion cores in the *n*-type material and negative ion cores in the *p*-type material. The electric field sweeps free carriers out of this region and hence it is called depletion region as it is depleted of free carriers. A barrier potential V_b due to the electric field E is formed at the junction as shown in Figure 9.9(c).

As this diffusion of charge carriers from both sides continues, the negative ions form a layer of negative space charge region along the *p*-side. Similarly, a positive space charge region is formed by positive ions on the *n*-side. The positive space charge region attracts electrons from *p*-side to *n*-side and the negative space charge region attracts holes from *n*-side to *p*-side. This moment of carriers happen in this region due to the formed electric field and it constitutes a current called drift current. The diffusion current and drift current flow in the opposite direction and at one instant they both become equal. Thus, a p-n junction is formed.

9.3.1.2 Junction potential or barrier potential

The recombination of charge carriers takes place only to a certain point beyond which the depletion layer acts like a barrier to further diffusion of free charges across the junction.

This is due to the fact that the immobile ions on both sides establish an electric potential difference across the junction. Therefore, an electron trying to diffuse into the interior of the depletion region encounters a negative wall of ions repelling it backwards. If the free electron has enough energy, it can break through the wall and enter into the *p*-region, where it can recombine with a hole and create another negative ion.

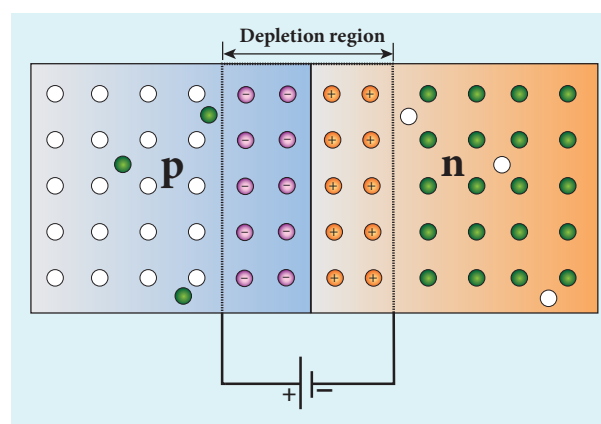

Figure 9.10 Barrier potential formed across the junction

The strength of the electric potential difference across the depletion region keeps increasing with the crossing of each electron until equilibrium is reached; at this point, the internal repulsion of the depletion layer stops further diffusion of free electrons across the junction. This difference in potential across the depletion layer is called the **barrier potential** as shown in Figure 9.10. At 25°C, this barrier potential approximately equals 0.7 V for Silicon and 0.3 V for Germanium.

9.3.2 P-N Junction diode

A p-n junction diode is formed when a p-type semiconductor is fused with an-type semiconductor. It is a device with single p-n junction as shown in Figure 9.11(a). The circuit symbol is shown in Figure 9.11(b).

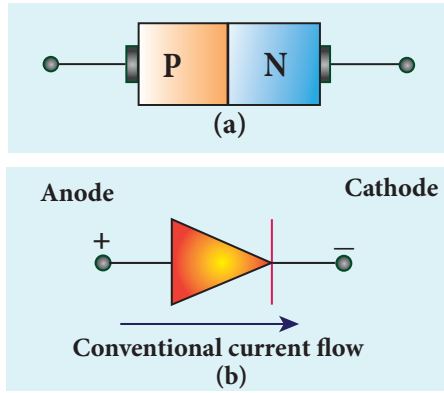

Figure 9.11 p-n junction diode
 (a) Schematic representation
 (b) Circuit symbol

9.3.2.1 Biasing a diode

Biasing means providing external energy to charge carriers to overcome the barrier potential and make them move in a particular direction. The charge carriers can either move towards the junction or away from the junction. **The external voltage applied to the p-n junction is called bias voltage.** Depending on the polarity of the external source to the p-n junction we have two types of biasing

1. Forward bias
2. Reverse bias

Forward Bias

If the positive terminal of the external voltage source is connected to the p-side and the negative terminal to the n-side, it is called forward biased as shown in Figure 9.12. The application of a forward bias potential makes the electrons move into the n-side and the holes into the p-side. This initiates the recombination with the ions near the junction which in turn reduces the width of the depletion region and hence the barrier potential.

The electron from the n-side is now accelerated towards the p-side as it experiences a reduced barrier potential at

the junction. In addition, the accelerated electrons experience a strong attraction by the positive potential applied to the p-side. This results in the movement of electrons towards the p-side and in turn, holes towards the n-side. When the applied voltage is increased, the width of the depletion region and hence the barrier potential are further reduced. This results in a large number of electrons passing through the junction resulting in an exponential rise in current through the junction.

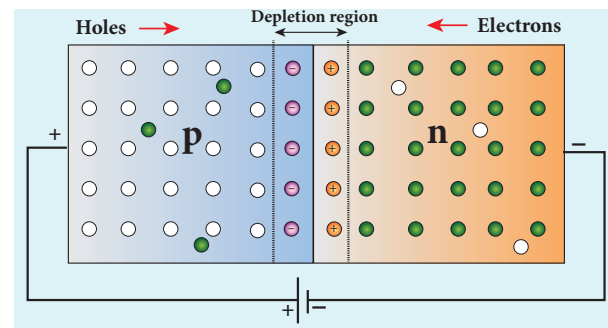

Figure 9.12 Schematic representation of a p-n junction diode under forward bias

Reverse Bias

If the positive terminal of the battery is connected to the n-side and the negative potential to the p-side, the junction is said to be reverse biased as shown in Figure 9.13.

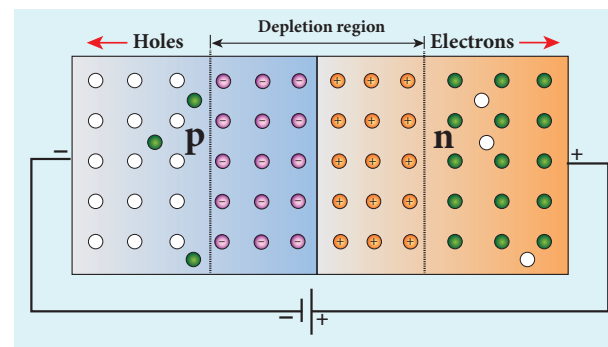

Figure 9.13 Schematic representation of a p-n junction diode under reverse bias

As the positive potential is connected to the n-type material, the electrons in the n-type material are attracted towards the



positive terminal in turn, the holes in the p-type material move towards the negative terminal (both away from the junction). It increases the immobile ions at the junction. The net effect is the widening of the depletion region. This leads to an increase in the barrier potential. Consequently, the majority charge carriers from both sides experience a great barrier to cross the junction. This reduces the diffusion current across the junction effectively.

Yet, a small current flows across the junction due to the minority charge carriers in both regions. The reverse bias for majority charge carriers serves as the forward bias for minority charge carriers. The current that flows under a reverse bias is called the reverse saturation current. It is represented as I_s .

The reverse saturation current is independent of the applied voltage and it depends only on the thermally generated minority charge carriers. Even a small voltage is sufficient enough to drive the minority charge carriers across the junction.

Note The reverse saturation current of a silicon diode doubles for every 10°C rise in temperature.

9.3.3 Characteristics of a junction diode

9.3.3.1 Forward characteristics

It is the study of the variation in current through the diode with respect to the applied voltage across the diode when it is forward biased.

The p-n junction diode is forward biased as shown in Figure 9.14(a). An external resistance (R) is used to limit the flow of current through the diode. The voltage across

the diode is varied by varying the biasing voltage across the dc power supply. The forward bias voltage and the corresponding forward bias current are noted. A graph is plotted by taking the forward bias voltage (V) along the x-axis and the current (I) through the diode along the y-axis. This graph is called the **forward V-I characteristics** of the p-n junction diode and is shown in Figure 9.14(b). Three inferences can be brought out from the graph:

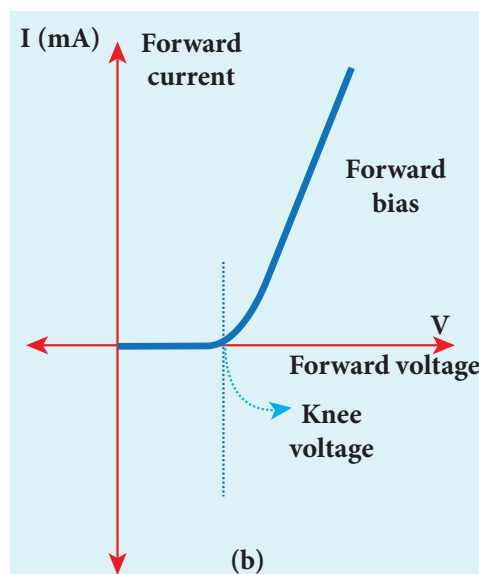
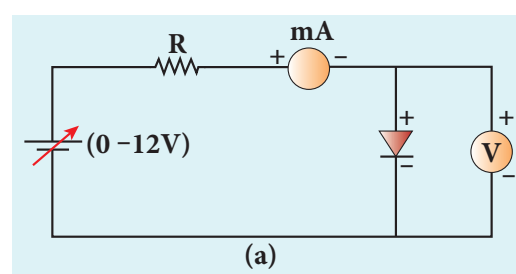

Figure 9.14 p-n junction diode (a) diode under forward bias (b) forward characteristics

- (i) At room temperature, a potential difference equal to the barrier potential is required before a reasonable forward current starts flowing across the diode. This voltage is known as **threshold voltage or cut-in voltage or knee voltage** (V_{th}). It is approximately

0.3 V for Germanium and 0.7 V for Silicon. The current flow is negligible when the applied voltage is less than the threshold voltage. Beyond the threshold voltage, increase in current is significant even for a small increase in voltage.

- (ii) The graph clearly infers that the current flow is not linear and is exponential. Hence it does not obey Ohm's law.
- (iii) The forward resistance (r_f) of the diode is the ratio of the small change in voltage (ΔV) to the small change in current (ΔI), $r_f = \frac{\Delta V}{\Delta I}$.
- (iv) Thus the diode behaves as a conductor when it is forward biased.

However, if the applied voltage is increased beyond a rated value, it will produce an extremely large current which may destroy the junction due to overheating. This is called as the breakdown of the diode and the voltage at which the diode breaks down is called the breakdown voltage. Thus, it is safe to operate a diode well within the threshold voltage and the breakdown voltage.

9.3.3.2 Reverse characteristics

The circuit to study the reverse characteristics is shown in Figure 9.15(a). In the reverse bias, the p-region of the diode is connected to the negative terminal and n-region to the positive terminal of the dc power supply.

A graph is drawn between the reverse bias voltage and the current across the junction, which is called the reverse characteristics of a p-n junction diode. It is shown in Figure 9.15(b). Under this bias, a very small current in μA , flows across the junction. This is due to the flow of the minority charge carriers called the leakage current or reverse

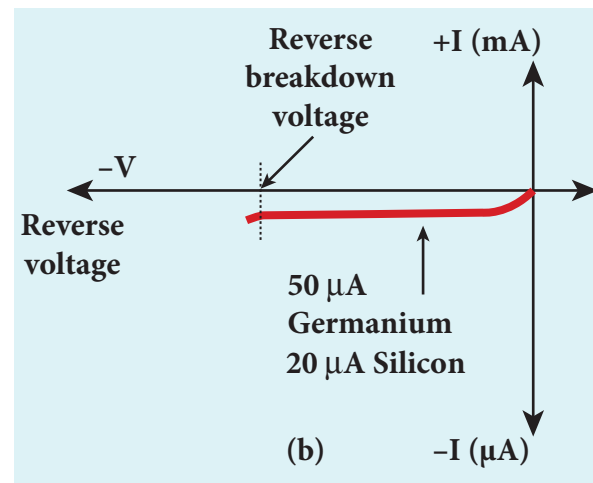
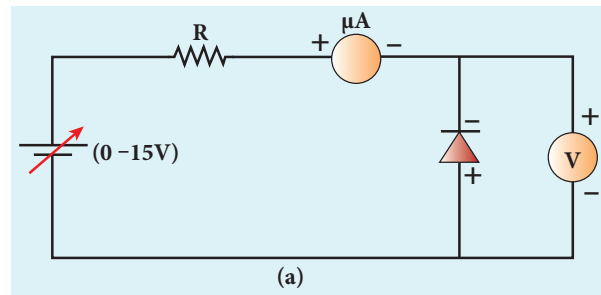

Figure 9.15 p-n junction diode (a) diode under reverse bias (b) reverse characteristics

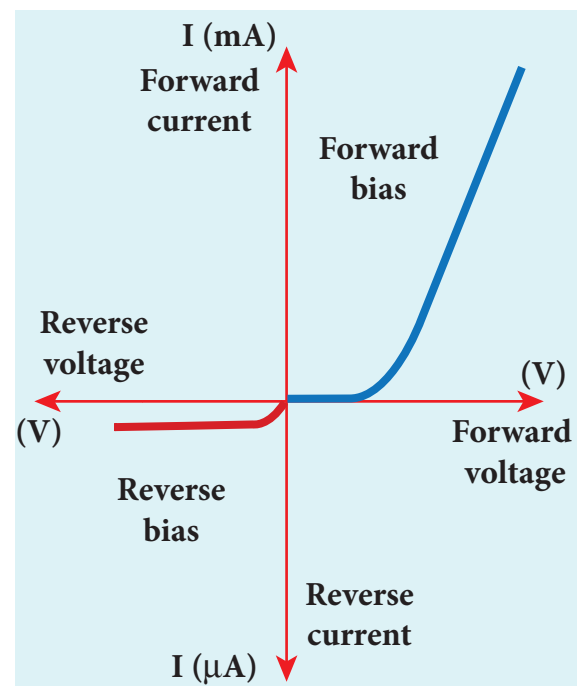

Figure 9.16 Forward and reverse characteristics of a diode

saturation current. Besides, the current is almost independent of the voltage. The reverse bias voltage can be increased only up to the rated value otherwise the diode will enter into the breakdown region.



Note Ideal diode: It acts like a conductor when it is forward biased. When it is reverse biased, it acts like an insulator. The barrier potential is assumed to be zero and hence it behaves like a resistor.

The forward and reverse characteristics are given in one graph as shown in Figure 9.16.



EXAMPLE 9.1

An ideal diode and a $5\ \Omega$ resistor are connected in series with a $15\ \text{V}$ power supply as shown in figure below. Calculate the current that flows through the diode.

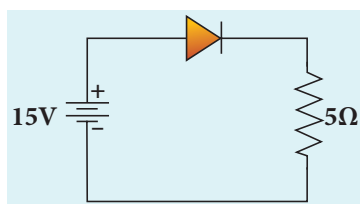

Solution

The diode is forward biased and it is an ideal one. Hence, it acts like a closed switch with no barrier voltage. Therefore, current that flows through the diode can be calculated using Ohm's law.

$$V = IR$$

$$I = \frac{V}{R} = \frac{15}{5} = 3\ \text{A}$$

EXAMPLE 9.2

Consider an ideal junction diode. Find the value of current flowing through AB is



Solution

The barrier potential of the diode is neglected as it is an ideal diode.

The value of current flowing through AB can be obtained by using Ohm's law

$$I = \frac{V}{R} = \frac{3 - (-7)}{1 \times 10^3} = \frac{10}{10^3} = 10^{-2}\ \text{A} = 10\ \text{mA}$$

9.3.4 Rectification

The process of converting alternating current into direct current is called **rectification**. In this section, we will discuss two types of rectifiers namely, half wave rectifier and full wave rectifier.

9.3.4.1 Half wave rectifier circuit

The half wave rectifier circuit is shown in Figure 9.17(a). The circuit consists of a transformer, a p-n junction diode and a resistor. In a half wave rectifier circuit, either a positive half or the negative half of the AC input is passed through while the other half is blocked. Only one half of the input wave reaches the output. Therefore, it is called half wave rectifier. Here, a p-n junction diode acts as a rectifier diode.

During the positive half cycle

When the positive half cycle of the ac input signal passes through the circuit, terminal A becomes positive with respect to terminal B. The diode is forward biased and hence it conducts. The current flows

through the load resistor R_L and the AC voltage developed across R_L constitutes the output voltage V_o and the waveform of the diode current is shown in Figure 9.17(b).

During the negative half cycle

When the negative half cycle of the ac input signal passes through the circuit, terminal A is negative with respect to terminal B. Now the diode is reverse biased and does not conduct and hence no current passes through R_L . The reverse saturation current in a diode is negligible. Since there is no voltage drop across R_L , the negative half cycle of ac supply is suppressed at the output. The output waveform is shown in Figure 9.17b.

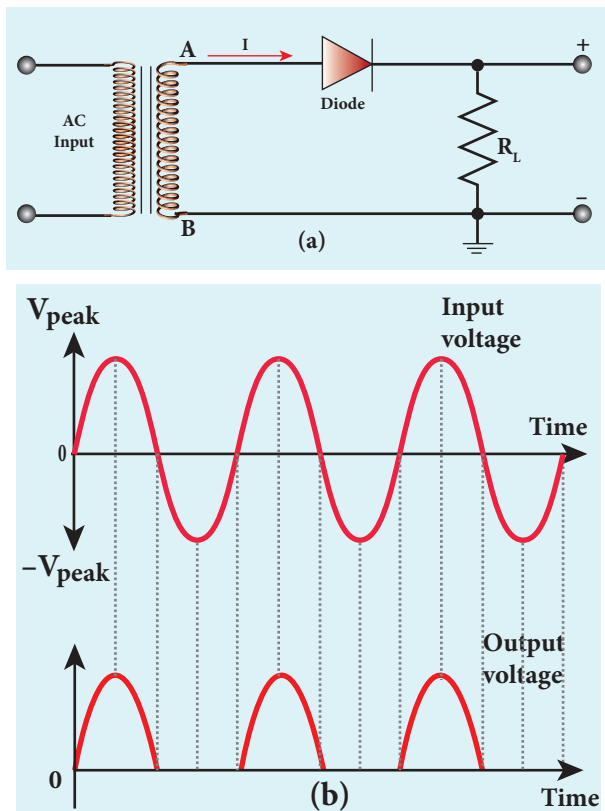

Figure 9.17 (a) Input ac signal (b) half wave rectifier circuit (c) input and output waveforms

The output of the half wave rectifier is not a steady dc voltage but a pulsating wave. This pulsating voltage can not be used

for electronic equipments. A constant or a steady voltage is required which can be obtained with the help of filter circuits and voltage regulator circuits.

Efficiency (η) is the ratio of the output dc power to the ac input power supplied to the circuit. Its value for half wave rectifier is 40.6 %



Note If the direction of the diode is reversed, the negative half of the ac signal is passed through and the positive half is blocked.

9.3.4.1 Full wave rectifier

The positive and negative half cycles of the AC input signal pass through the full wave rectifier circuit and hence it is called the full wave rectifier. The circuit is shown in Figure 9.18(a). It consists of two p-n junction diodes, a center tapped

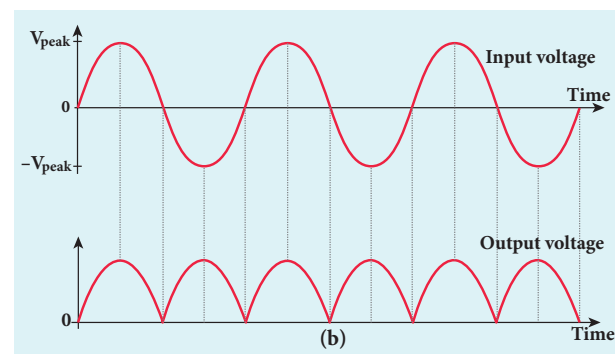
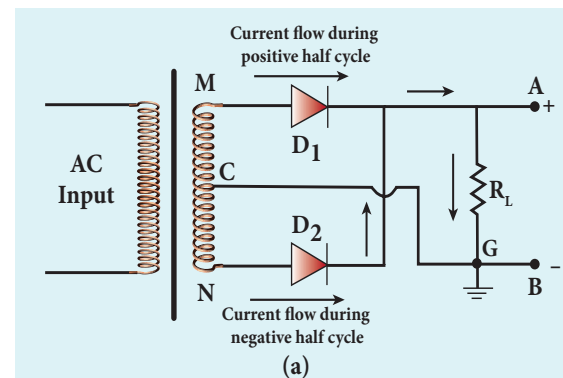

Figure 9.18 (a) Full wave rectifier circuit (b) Input and output waveforms



transformer, and a load resistor (R_L). The centre is usually taken as the ground or zero voltage reference point. Due to the centre tap transformer, the output voltage rectified by each diode is only one half of the total secondary voltage.

During positive half cycle

When the positive half cycle of the ac input signal passes through the circuit, terminal M is positive, G is at zero potential and N is at negative potential. This forward biases diode D_1 and reverse biases diode D_2 . Hence, being forward biased, diode D_1 conducts and current flows along the path MD_1AGC . As a result, positive half cycle of the voltage appears across R_L in the direction G to C

During negative half cycle

When the negative half cycle of the ac input signal passes through the circuit, terminal N is positive, G is at zero potential and M is at negative potential. This forward biases diode D_2 and reverse biases diode D_1 . Hence, being forward biased, diode D_2 conducts and current flows along the path ND_2BGC . As a result, negative half cycle of the voltage appears across R_L in the same direction from G to C

Hence in a full wave rectifier both positive and negative half cycles of the input signal pass through the load in the same direction as shown in Figure 9.18(b). Though both positive and negative half cycles of ac input are rectified, the output is still pulsating in nature.

The efficiency (η) of full wave rectifier is twice that of a half wave rectifier and is found to be 81.2 %. It is because both the positive and negative half cycles of the ac input source are rectified.



Note

Centre tap transformer: There is a facility to tap at halfway point in the secondary windings. This helps to measure the induced voltage from one end of the secondary to the centre point. If the centre tap point is grounded then the voltage applied across the secondary will be divided by half. For example, if the voltage applied across the secondary is 240 V, then the voltage across one end and the centre tap point is +120 V and at the other end it is -120 V.

9.3.5 Breakdown mechanism

The reverse current or the reverse saturation current due to the minority charge carriers is small. If the reverse bias applied to a p-n junction is increased beyond a point, the junction breaks down and the reverse current rises sharply. The voltage at which this happens is called the breakdown voltage and it depends on the width of the depletion region, which in turn depends on the doping level.

A normal p-n junction diode gets damaged at this point. Specially designed diodes like Zener diode can be operated at this region and can be used for the purpose of voltage regulation in circuits. There are two mechanisms that are responsible for breakdown under increasing reverse voltage.

9.3.5.1 Zener breakdown

Heavily doped p-n junctions have narrow depletion layers of the order of $<10^{-6}$ m. When a reverse voltage across this junction is increased to the breakdown limit, a very strong electric field of strength 3×10^7 V m⁻¹ is set up across the narrow layer. This

electric field is strong enough to break or rupture the covalent bonds in the lattice and thereby generating electron-hole pairs. This effect is called **Zener effect**.

Even a small further increase in reverse voltage produces a large number of charge carriers. Hence the junction has very low resistance in the breakdown region. This process of emission of electrons due to the rupture of bands in from the lattice due to strong electric field is known as **internal field emission or field ionization**. The electric field required for this is of the order of 10^6 V m^{-1} .

9.3.5.2 Avalanche breakdown

Avalanche breakdown occurs in lightly doped junctions which have wide depletion layers. Here, in this case, the electric field is not strong enough to produce breakdown. Alternatively, the thermally generated minority charge carriers accelerated by the electric field gains sufficient kinetic energy, collide with the semiconductor atoms while passing through the depletion region. This leads to the breaking of covalent bonds and in turn generates electron-hole pairs.

The newly generated charge carriers are also accelerated by the electric field resulting in more collisions and further production of charge carriers. This cumulative process leads to an avalanche of charge carriers across the junction and consequently reduces the reverse resistance. The diode current increases sharply.



- For a reverse voltage of,
- (i) less than 4V → Zener effect predominates
 - (ii) greater than 6V → Avalanche effect predominates
 - (iii) between 4 and 6V → both effects are present.

9.3.6 Zener diode

Zener diode is a heavily doped silicon diode used in reverse biased condition and is named after its inventor C. Zener. It is specially designed to be operated in the breakdown region. The doping level of the Silicon diode can be varied to have a wide range of breakdown voltages from 2 V to over 1000 V.

As explained in the previous section, Zener breakdown occurs due to the breaking of covalent bonds by the strong electric field set up in the depletion region by the reverse voltage. It produces an extremely large number of electrons and holes which constitute the reverse saturation current. The current is limited by both external resistance and power dissipation of the diode. A Zener diodes is shown in Figure 9.19(a) and its circuit symbol of Zener diode is shown in Figure 9.19(b).

It looks like an ordinary p-n junction diode except the cathode lead approximating the shape of a 'z' letter. The arrow head points the direction of conventional current. In Figure 9.19(a), black ring indicates the cathode lead.



Figure 9.19 Zener diode (a) commercial picture (b) circuit symbol

9.3.6.1 V-I Characteristics of Zener diode

The circuit to study the forward and reverse characteristics of a Zener diode is shown in Figure 9.20(a) and Figure 9.20 (b). The V-I characteristics of a Zener diode is shown in Figure 9.20(c). The forward characteristic of a Zener diode is similar to that of an ordinary p-n junction diode. It starts conducting approximately around 0.7 V. However, the reverse characteristics is highly significant in Zener diode. The increase in reverse voltage

normally generates very small reverse current. While in Zener diode, when the reverse voltage is increased to the breakdown voltage (V_Z), the increase in current is very sharp. The voltage remains almost constant throughout the breakdown region. In Figure 9.20(c), $I_{Z(max)}$ represents the maximum reverse current. If the reverse current is increased further, the diode will be damaged. The important parameters on the reverse characteristics are

$V_Z \rightarrow$ Zener breakdown voltage

$I_{Z(min)} \rightarrow$ minimum current to sustain breakdown

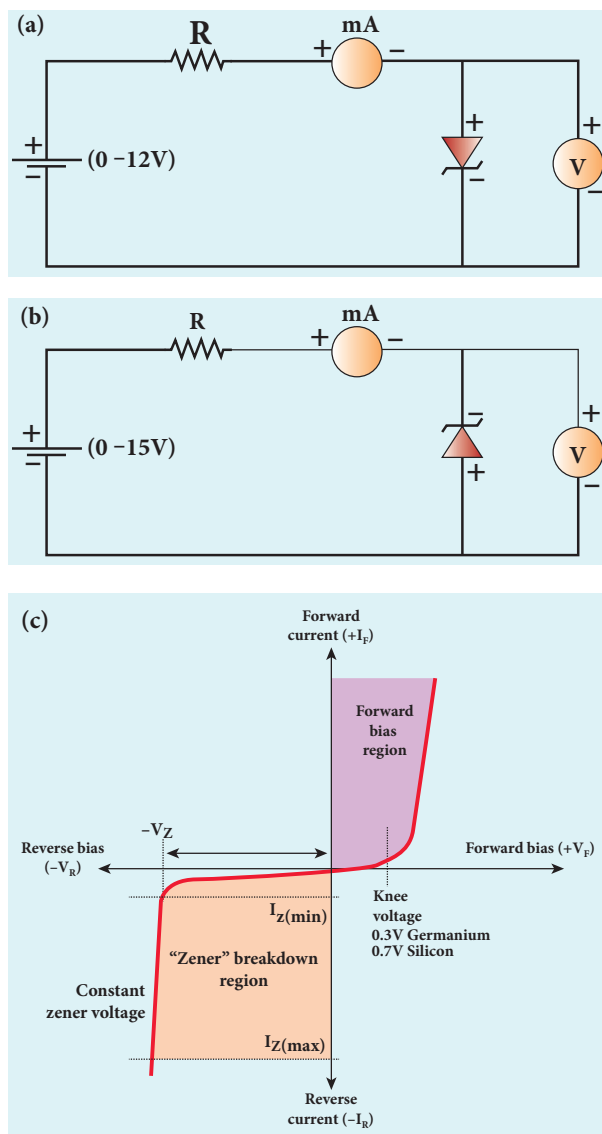

Figure 9.20 Zener diode (a) forward bias (b) reverse bias (c) V-I characteristics

$I_{Z(max)} \rightarrow$ maximum current limited by maximum power dissipation.

The Zener diode is operated in the reverse bias having the voltage greater than V_Z and current less than $I_{Z(max)}$. The reverse characteristic is not exactly vertical which means that the diode possesses some small resistance called Zener dynamic impedance. Zener resistance is the inverse of the slope in the breakdown region. It means an increase in the Zener current produces only a very small increase in the reverse voltage. However this can be neglected. The voltage of an ideal Zener diode does not change once it goes into breakdown. It means that V_Z remains almost constant even when I_Z increases considerably.



Note The maximum reverse bias that can be applied before entering into the Zener region is called the Peak inverse voltage. Commercially referred as PIV rating.

Applications

The zener diode can be used as

1. Voltage regulators
2. Calibrating voltages
3. Provide fixed reference voltage in a network for biasing
4. Protection of any gadget against damage from accidental application of excessive voltage.

9.3.6.2 Zener diode as a voltage regulator

A Zener diode working in the breakdown region can serve as a voltage regulator. It maintains a constant output voltage even when input voltage V_i or load current I_L varies. The circuit used for the same is shown in Figure 9.21. Here in this circuit, the input voltage V_i is regulated at a constant voltage,

V_z (Zener voltage) at the output represented as V_o using a Zener diode. The output voltage is maintained constant as long as the input voltage does not fall below V_z .

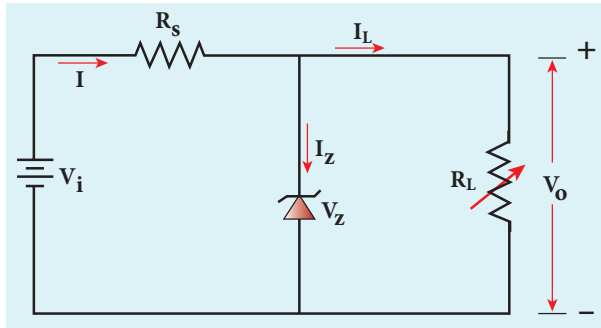

Figure 9.21 Circuit to study voltage regulation by Zener diode

When the potential developed across the diode is greater than V_z , the diode moves into the Zener breakdown region. It conducts and draws relatively large current through the series resistance R_s . The total current I passing through R_s equals the sum of diode current I_z and load current I_L ($I = I_z + I_L$). It is to be noted that the total current is always less than the maximum Zener diode current.

Under all conditions $V_o = V_z$. Thus, output voltage is regulated.

EXAMPLE: 9.3

Find the current through the Zener diode when the load resistance is $1\text{ K}\Omega$. Use diode approximation.

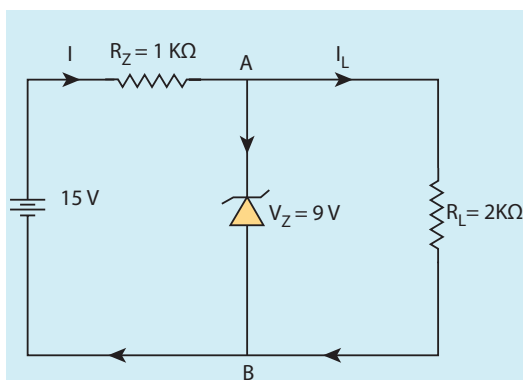

Solution

Voltage across AB is $V_z = 9\text{V}$

Voltage drop across $R = 15 - 9 = 6\text{V}$

Therefore current through the resistor R ,

$$I = \frac{6}{1 \times 10^3} = 6\text{ mA}$$

Voltage across the load resistor = $V_{AB} = 9\text{V}$

Current through load resistor,

$$I_L = \frac{V_{AB}}{R_L} = \frac{9}{2 \times 10^3} = 4.5\text{ mA}$$

The current through the Zener diode,

$$I_z = I - I_L = 6\text{ mA} - 4.5\text{ mA} = 1.5\text{ mA}$$

9.3.7 Optoelectronic devices

Optoelectronics deals with devices which convert electrical energy into light and light into electrical energy through semiconductors. Optoelectronic device is an electronic device which utilizes light for useful applications. We will discuss some important optoelectronic devices namely, light emitting diodes, photo diodes and solar cells.

9.3.7.1 Light Emitting Diode (LED)

LED is a p-n junction diode which emits visible or invisible light when it is forward biased. Since, electrical energy is converted into light energy, this process is also called electroluminescence. The circuit symbol of LED is shown in Figure 9.22(a).

The cross-sectional view of a commercial LED is shown in Figure 9.22(b). It consists of a p-layer, n-layer and a substrate. A transparent window is used to allow light to travel in the desired direction. An external resistance in series with the biasing source is required to limit the forward current through the LED. In addition, it has two leads; anode and cathode.

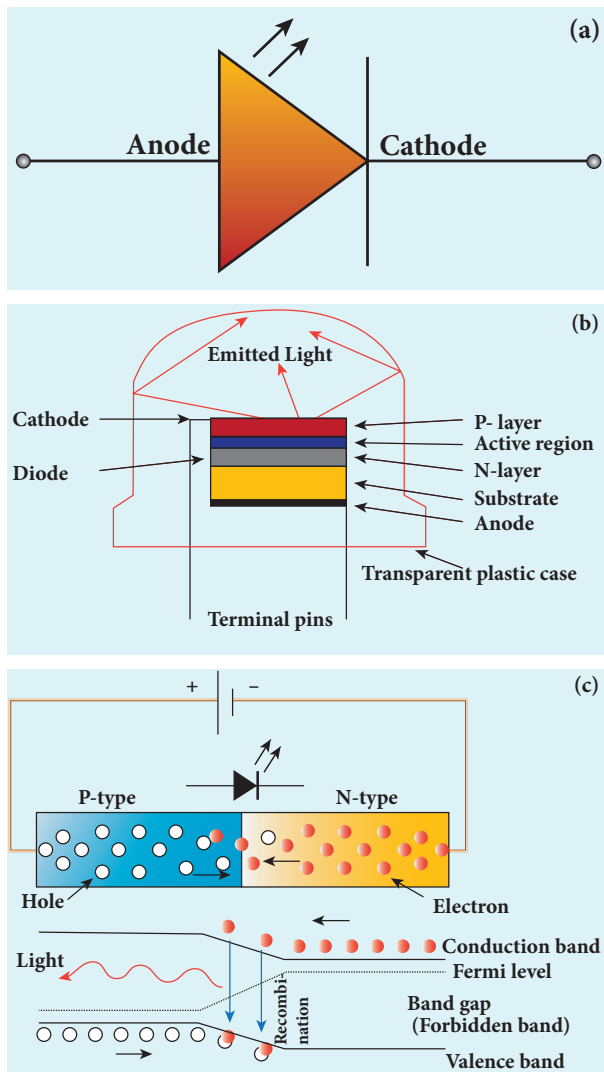

Figure 9.22 (a) Circuit symbol of LED (b) Inside view of LED (c) Schematic diagram to explain recombination process

When the p-n junction is forward biased, the conduction band electrons on n-side and valence band holes on p-side diffuse across the junction. When they cross the junction, they become excess minority carriers (electrons in p-side and holes in n-side). These excess minority carriers recombine with oppositely charged majority carriers in the respective regions, i.e. the electrons in the conduction band recombine with holes in the valence band as shown in the Figure 9.22(c).

During recombination process, energy is released in the form of light (radiative) or heat (non-radiative). For radiative recombination, a photon of energy $h\nu$ is

emitted. For non-radiative recombination, energy is liberated in the form of heat.

The colour of the light is determined by the energy band gap of the material. Therefore, LEDs are available in a wide range of colours such as blue (SiC), green (AlGaP) and red (GaAsP). Now a days, LED which emits white light (GaInN) is also available.

Applications

- Indicator lamps on the front panel of the scientific and laboratory equipments.
- Seven-segment displays.
- Traffic signals, emergency vehicle lighting etc.
- Remote control of television, airconditioner etc.



EXAMPLE 9.4

Determine the wavelength of light emitted from LED which is made up of GaAsP semiconductor whose forbidden energy gap is 1.875 eV. Mention the colour of the light emitted (Take $h = 6.6 \times 10^{-34}$ Js).

Solution

$$E_g = \frac{hc}{\lambda}$$

Therefore,

$$\lambda = \frac{hc}{E_g} = \frac{6.6 \times 10^{-34} \times 3 \times 10^8}{1.875 \times 1.6 \times 10^{-19}} = 660 \text{ nm}$$

The wavelength 660 nm corresponds to red colour light.

9.3.7.2 Photodiodes

A p-n junction diode which converts an optical signal into electric signal is known as photodiode. Thus, the operation of

photodiode is exactly inverse to that of an LED. Photo diode works in reverse bias. Its circuit symbol is shown in Figure 9.23(a). The direction of arrows indicates that the light is incident on the photo diode.

The device consists of a p-n junction semiconductor made of photosensitive material kept safely inside a plastic case as shown in Figure 9.23(b). It has a small transparent window that allows light to be incident on the p-n junction. Photodiodes can generate current when the p-n junction is exposed to light and hence are called as light sensors.

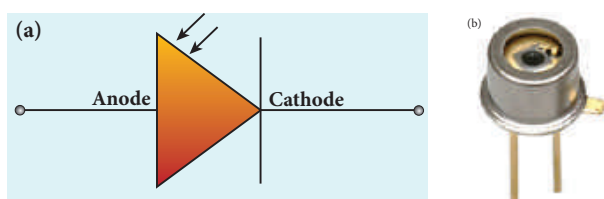

Figure 9.23 (a) Circuit symbol
(b) Schematic view of photodiode

When a photon of sufficient energy ($h\nu$) strikes the depletion region of the diode, some of the valence band electrons are elevated into conduction band, in turn holes are developed in the valence band. This creates electron-hole pairs. The amount of electron-hole pairs generated depends on the intensity of light incident on the p-n junction.

These electrons and holes are swept across the p-n junction by the electric field created by reverse voltage before recombination takes place. Thus, holes move towards the n-side and electrons towards the p-side. When the external circuit is made, the electrons flow through the external circuit and constitute the photocurrent.

When the incident light is zero, there exists a reverse current which is negligible. This reverse current in the absence of any incident light is called dark current and is due to the thermally generated minority carriers.

Applications

- Alarm system
- Count items on a conveyer belt
- Photoconductors
- Compact disc players, smoke detectors
- Medical applications such as detectors for computed tomography etc.

9.3.7.2 Solar cell

A solar cell, also known as photovoltaic cell, converts light energy directly into electricity or electric potential difference by **photovoltaic effect**. It is basically a p-n junction which generates emf when solar radiation falls on the p-n junction. A solar cell is of two types: p-type and n-type.

Both types use a combination of p-type and n-type Silicon which together forms the p-n junction of the solar cell. The difference is that p-type solar cells use p-type Silicon as the base with an ultra-thin layer of n-type Silicon as shown in Figure 9.24, while n-type solar cell uses the opposite combination. The other side of the p-Silicon is coated with metal which forms the back electrical contact. On top of the n-type Silicon, metal grid is deposited which acts as the front electrical contact. The top of the solar cell is coated with anti-reflection coating and toughened glass.

In a solar cell, electron-hole pairs are generated due to the absorption of light

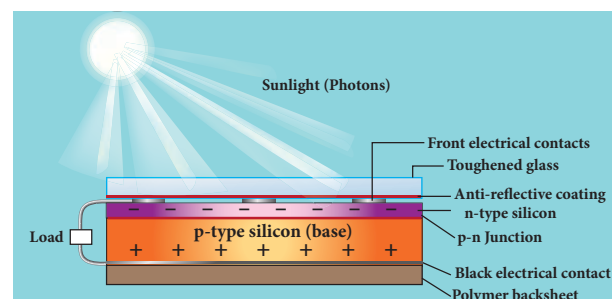

Figure 9.24 Cross-sectional view of a solar cell

near the junction. Then the charge carriers are separated due to the electric field of the depletion region. Electrons move towards n-type Silicon and holes move towards p-type Silicon layer. The electrons reaching the n-side are collected by the front contact and holes reaching p-side are collected by the back electrical contact. Thus a potential difference is developed across solar cell. When an external load is connected to the solar cell, photocurrent flows through the load.

Many solar cells are connected together either in series or in parallel combination to form solar panel or module. Many solar panels are connected with each other to form solar arrays. For high power applications, solar panels and solar arrays are used.

Applications:

- Solar cells are widely used in calculators, watches, toys, portable power supplies, etc.
- Solar cells are used in satellites and space applications
- Solar panels are used to generate electricity.

9.4

THE BIPOLAR JUNCTION TRANSISTOR [BJT]

Introduction

In 1951, William Shockley invented the modern version of transistor. It is a semiconductor device that led to a technological revolution in the twentieth century. The heat loss in transistor is very less. This has laid the foundation of integrated chips which contain thousands of miniaturized transistors. The emergence of the integrated chips led to increasing applications in the fast developing electronics industry.

Bipolar Junction Transistor

The BJT consists of a semiconductor (Silicon or Germanium) crystal in which an n-type material is sandwiched between two p-type materials (PNP transistor) or a p-type material sandwiched between two n-type materials (NPN transistor). To protect it against moisture, it is sealed inside a metal or a plastic case. The two types of transistors with their circuit symbols are shown in Figure 9.25.

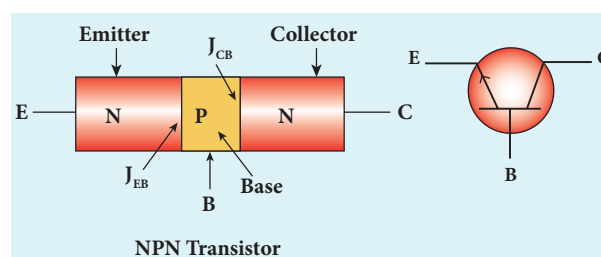

(a)

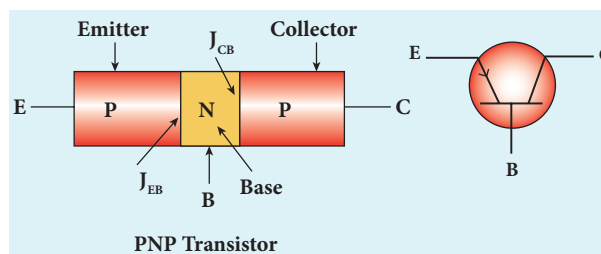

(b)

Figure 9.25 Schematic Diagram of
(a) NPN transistor and circuit symbol
(b) PNP transistor and circuit symbol

The three regions formed are called as emitter, base and collector which are provided with terminals or ohmic contacts labeled as E, B, and C. As a BJT has two p-n junctions, two depletion layers are formed across the emitter-base junction (J_{EB}) and collector-base junction (J_{CB}) respectively. The circuit symbol carries an arrowhead at the emitter lead pointing from p to n indicating the direction of conventional current.

Emitter:

The main function of the emitter is to supply majority charge carriers to the

collector region through the base region. Hence, emitter is more heavily doped than the other two regions.

Base:

Base is very thin (10^{-6} m) and very lightly doped compared to the other two regions.

Collector:

The main function of collector is to collect the majority charge carriers supplied by the emitter through the base. Hence, collector is made physically larger than the other two as it has to dissipate more power. Its is modarately dopped.

DO YOU KNOW? Because of the differing size and the amount of doping, the emitter and collector cannot be interchanged.

Transistor Biasing

The application of suitable dc voltages across the transistor terminals is called biasing.

Different modes of transistor biasing

Forward Active:

In this bias the emitter-base junction is forward biased and the collector-base junction is reverse biased. The transistor is in the active mode of operation. In this mode, the transistor functions as an amplifier.

Saturation:

Here, the emitter-base junction and collector-base junction are forward biased. The transistor has a very large flow of currents across the junctions. In this mode, transistor is used as a closed switch.

Cut-off:

In this bias, the emitter-base junction and collector-base junction are reverse biased. Transistor in this mode is an open switch.

Note In a PNP transistor, base and collector will be negative with respect to emitter indicated by the middle letter N whereas base and collector will be positive in an NPN transistor [indicated by the middle letter P]

9.4.1 Transistor circuit configurations

There are three types of circuit connections for operating a transistor based on the terminal that is used in common to both input and output circuits.

9.4.1.1 Common-Base (CB) configuration

The base is common to both the input and output circuits. The schematic and circuit symbol are shown in Figure 9.26(a) and 9.26(b). The input current is the emitter current I_E and the output current is the collector current I_C . The input signal is applied between emitter and base, the output is measured between collector and base.

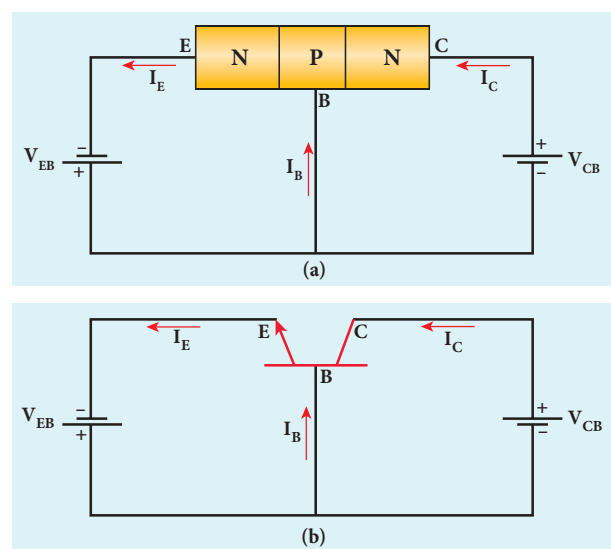

Figure 9.26 NPN transistor in common base configuration (a) schematic circuit diagram (b) circuit symbol

9.4.1.2 Common-Emitter(CE)configuration

In this configuration, the emitter is common to both the input and output loops as shown in Figure 9.27. Base current, I_B is the input current and the collector current, I_C is the output current. The input signal is applied between the emitter and base and the output is measured between the collector and the emitter.

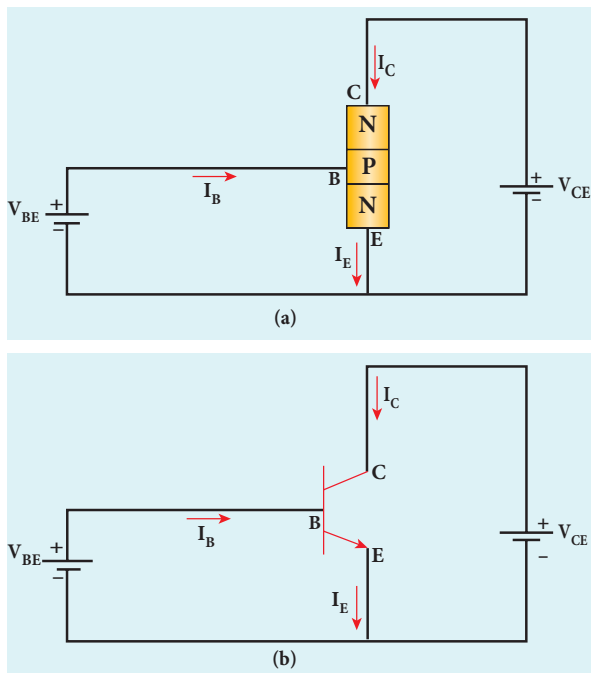

Figure 9.27 NPN transistor in common emitter configuration (a) schematic circuit diagram (b) circuit symbol

9.4.1.3 Common-Collector(CC)configuration

Here, the collector is common to both the input and output circuits as shown in Figure 9.28. The base current I_B is the input current, the emitter current I_E is the output current. The input signal is applied between the base and the collector, the output is measured between the emitter and collector.

Note As the output is taken from the emitter in common collector configuration, it is called an emitter follower.

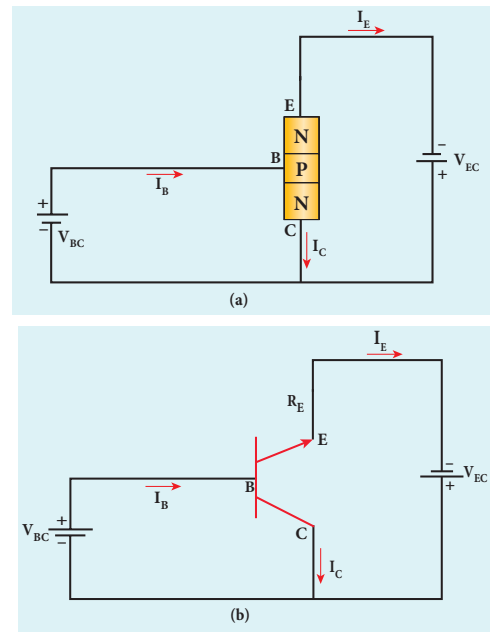

Figure 9.28 NPN transistor in common collector configuration (a) schematic circuit diagram (b) circuit symbol

9.4.2 Transistor action in the common base mode

The operation of an NPN transistor in the common base mode is explained below. The current flow in a common base NPN transistor in the forward active mode is shown in Figure 9.29.

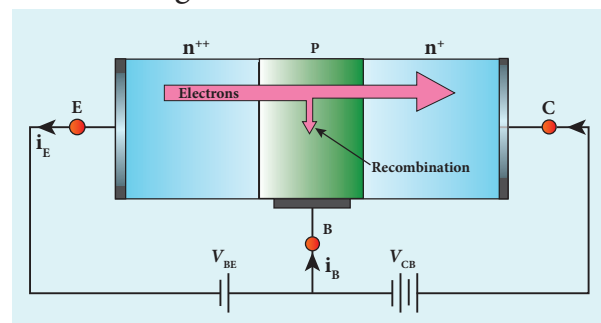

Figure 9.29 Flow of current in a NPN transistor

Basically, a BJT can be considered as two p-n junction diodes connected back-to-back. In the forward active bias of the transistor, the emitter-base junction is forward biased by a dc power supply V_{EB} and the collector-base junction is reverse



biased by the bias power supply V_{CB} . The forward bias decreases the depletion region across the emitter-base junction and the reverse bias increases the depletion region across the collector-base junction. Hence, the barrier potential across the emitter-base junction is decreased and the collector-base junction is increased. The voltage across the emitter-base junction is represented as V_{EB} and the collector-base junction as V_{CB} .

In an NPN transistor, the majority charge carriers in the emitter are electrons. As it is heavily doped, it has a large number of electrons. The forward bias across the emitter-base junction causes the electrons in the emitter region to flow towards the base region and constitutes the emitter current (I_E). The electrons after reaching the base region recombine with the holes in the base region. Since the base region is very narrow and lightly doped, all the electrons will not have sufficient holes to recombine and hence most of the electrons reach the collector region.

Eventually, the electrons that reach the collector region will be attracted by the collector terminal as it has positive potential and flows through the external circuit. This constitutes the collector current (I_C). The holes that are lost due to recombination in the base region are replaced by the positive potential of the bias voltage V_{EE} and constitute the base current (I_B). The magnitude of the base current will be in microamperes as against milliamperes for emitter and collector currents.

It is to be noted that if the emitter current is zero, then the collector current is almost zero. It is therefore imperative that a BJT is called a current controlled device. Applying Kirchoff's law, we can write the emitter current as the sum of the collector current and the base current.

$$I_E = I_B + I_C$$

Since the base current is very small, we can write, $I_E \approx I_C$. There is another component of collector current due to the thermally generated electrons called reverse saturation current, denoted as (I_{CO}). This factor is temperature sensitive. Therefore, care must be taken towards the stability of the system at high temperatures.

The ratio of the collector current to the emitter current is called the forward current gain (α_{dc}) of a transistor.

$$\alpha_{dc} = \frac{I_C}{I_E}$$

The α of a transistor is a measure of the quality of a transistor. Higher the value of α better is the transistor. It means that the collector current is closer to the emitter current. The value of α is less than unity and ranges from 0.95 to 0.99. This indicates that the collector current is 95% to 99% of the emitter current.



Note

1. The conventional flow of current is based on the direction of the motion of holes
2. In NPN transistor, current enters from the base into the emitter.
3. In a PNP transistor, current enters from the emitter into the base.
4. The emitter-base junction has low resistance and the collector-base junction has high resistance.

Working of a PNP transistor

The working of a PNP transistor is similar to the NPN transistor except for the fact that the emitter current I_E is due to holes and the base current I_B is due to electrons. However,

the current through the external circuit is due to the flow of electrons.

EXAMPLE 9.5

In a transistor connected in the common base configuration, $\alpha=0.95$, $I_E=1\text{ mA}$. Calculate the values of I_C and I_B .

Solution

$$\alpha = \frac{I_C}{I_E}$$

$$I_C = \alpha I_E = 0.95 \times 1 = 0.95\text{ mA}$$

$$I_E = I_B + I_C$$

$$\therefore I_B = I_C - I_E = 1 - 0.95 = 0.05\text{ mA}$$

9.4.3 Static Characteristics of Transistor in Common Emitter Mode

The know-how of certain parameters like the input resistance, output resistance, and current gain of a transistor are very important for the effective use of transistors in circuits. The circuit to study the static characteristics of an NPN transistor in the common emitter mode is given in Figure 9.30. The bias supply voltages V_{BB} and V_{CC} bias the base-emitter junction and collector-emitter junction respectively. The junction potential at the base-emitter is represented as V_{BE} and the collector-emitter as V_{CE} . The rheostats R_1 and R_2 are used to vary the base and collector currents respectively.

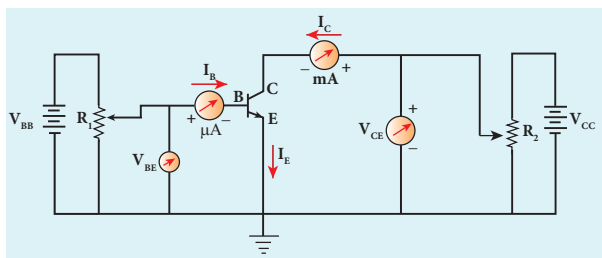

Figure 9.30 Static characteristics of a NPN transistor in common emitter configuration

The static characteristics of the BJT are

1. Input characteristics
2. Output characteristics
3. Transfer characteristics

9.4.3.1 Input Characteristics

Input Characteristics curves give the relationship between the base current (I_B) and base to emitter voltage (V_{BE}) at constant collector to emitter voltage (V_{CE}) and are shown in Figure 9.31.

Initially, the collector to emitter voltage (V_{CE}) is set to a particular voltage (above 0.7 V to reverse bias the junction). Then the base-emitter voltage (V_{BE}) is increased in suitable steps and the corresponding base-current (I_B) is recorded. A graph is plotted with V_{BE} along the x-axis and I_B along the y-axis. The procedure is repeated for different values of V_{CE} .

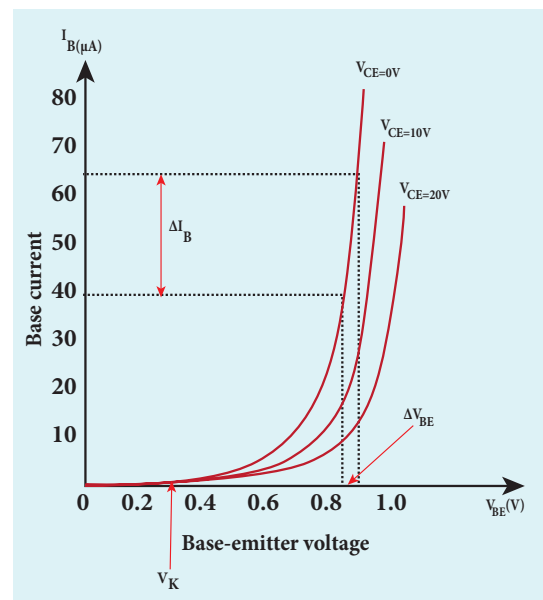

Figure 9.31 Input characteristics of a NPN transistor in common emitter configuration

The following observations are made from the graph.

- The curve looks like the forward characteristics of an ordinary p-n junction diode.

- There exists a threshold voltage or knee voltage (V_k) below which the base current is very small. The value is 0.7 V for Silicon and 0.3 V for Germanium transistors. Beyond the knee voltage, the base current increases with the increase in base-emitter voltage.
- It is also noted that the increase in the collector-emitter voltage decreases the base current. This shifts the curve outward. This is because the increase in collector-emitter voltage increases the width of the depletion region in turn, reduces the effective base width and thereby the base current.

Input impedance

The ratio of the change in base-emitter voltage (ΔV_{BE}) to the change in base current (ΔI_B) at a constant collector-emitter voltage (V_{CE}) is called the input impedance (r_i). The input impedance is not linear in the lower region of the curve.

$$r_i = \left(\frac{\Delta V_{BE}}{\Delta I_B} \right)_{V_{CE}}$$

The input impedance is high for a transistor in common emitter configuration.

9.4.3.2 Output Characteristics

The output characteristics give the relationship between the variation in the collector current (ΔI_C) with respect to the variation in collector-emitter voltage (ΔV_{CE}) at constant input current (I_B) as shown in Figure 9.32.

Initially, the base current (I_B) is set to a particular value. Then collector-emitter voltage (V_{CE}) is increased in suitable steps and the corresponding collector current (I_C) is recorded. A graph is plotted with the V_{CE} along the x-axis and I_C along the y-axis. This procedure is repeated for different values of

I_B . The four important regions in the output characteristics are:

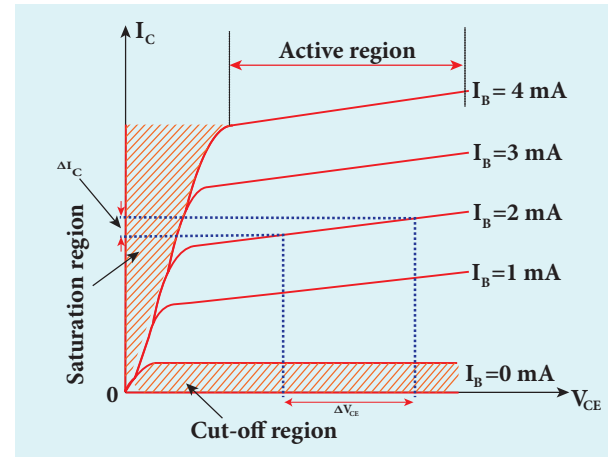

Figure 9.32 Output characteristics of a NPN transistor in common emitter configuration

(i). Saturation region

When V_{CE} is increased above 0 V, the I_C increases rapidly to a saturation value almost independent of I_B (Ohmic region, OA) called knee voltage. Transistors are always operated above this knee voltage.

(ii) Cut-off region

A small collector current (I_C) exists even after the base current (I_B) is reduced to zero. This current is due to the presence of minority carriers across the collector-base junction and the surface leakage current (I_{CEO}). This region is called as the cut-off region, because the main collector current is cut-off.

(iii) Active region

In this region, the emitter-base junction is forward biased and the collector-base junction is reverse biased. The transistor in this region can be used for voltage, current and power amplification.

(iv) Breakdown region

If the collector-emitter voltage (V_{CE}) is increased beyond the rated value given

by the manufacturer, the collector current (I_C) increases enormously leading to the junction breakdown of the transistor. This avalanche breakdown can damage the transistor.

Output impedance

The ratio of the change in the collector-emitter voltage (ΔV_{CE}) to the corresponding change in the collector current (ΔI_C) at constant base current (I_B) is called output impedance (r_o).

$$r_o = \left(\frac{\Delta V_{CE}}{\Delta I_C} \right)_{I_B}$$

The output impedance for transistor in common emitter configuration is very low.

9.4.3.3 Current transfer characteristics

This gives the variation of collector current (I_C) with changes in base current (I_B) at constant collector-emitter voltage (V_{CE}) as shown in Figure 9.33. It is seen that a small I_C flows even when I_B is zero. This current is called the common emitter leakage current (I_{CEO}), which is due to the flow of minority charge carriers.

Forward current gain

The ratio of the change in collector current (ΔI_C) to the change in base current (ΔI_B) at constant collector-emitter voltage (V_{CE}) is called forward current gain (β).

$$\beta = \left(\frac{\Delta I_C}{\Delta I_B} \right)_{V_{CE}}$$

Its value is very high and it generally ranges from 50 to 200. It depends on the construction of the transistor and will be provided by the manufacturer. There are transistors with β as high as 1000 as well.

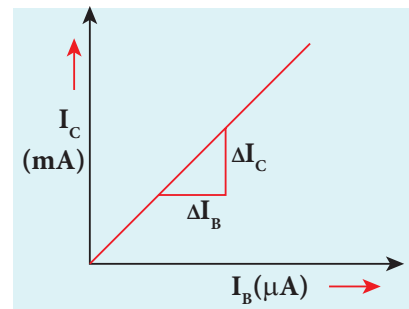

Figure 9.33 Current transfer characteristics of a NPN transistor common emitter configuration

9.4.3.4 Relation between α and β

There is a relation between current gain in the common base configuration α and current gain in the common emitter configuration β which is given below.

$$\alpha = \frac{\beta}{1 + \beta} \quad (\text{or}) \quad \beta = \frac{\alpha}{1 - \alpha}$$

EXAMPLE 9.6

The output characteristics of a transistor connected in common emitter mode is shown in the figure. Determine the value of I_C when $V_{CE} = 15$ V. Also determine the value of I_C when V_{CE} is changed to 10 V

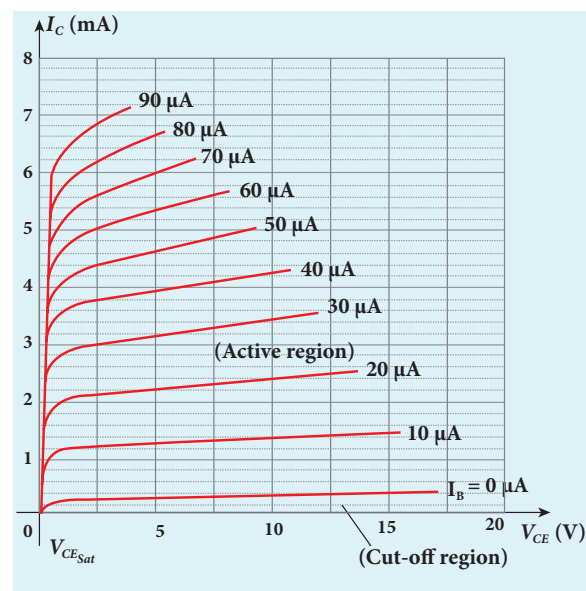

When $V_{CE} = 15$ V, $I_C = 1.5 \mu\text{A}$

When V_{CE} is changed to 10 V, $I_C = 1.4 \mu\text{A}$



The collector current is independent of the collector-emitter voltage in the active region.

EXAMPLE 9.7

In the circuit shown in the figure, the input voltage V_i is 20 V, $V_{BE} = 0$ V and $V_{CE} = 0$ V. What are the values of I_B , I_C , β ?

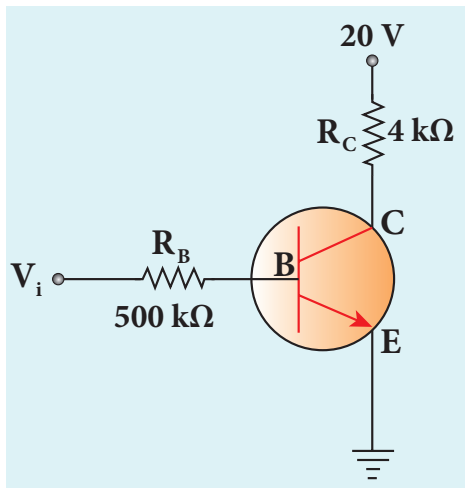

$$I_B = \frac{V_i}{R_B} = \frac{20 \text{ V}}{500 \text{ k}\Omega} = 40 \mu\text{A} \quad [\because V_{BE} = 0 \text{ V}]$$

$$I_C = \frac{V_{CC}}{R_C} = \frac{20 \text{ V}}{4 \text{ k}\Omega} = 5 \text{ mA} \quad [\because V_{CE} = 0 \text{ V}]$$

$$\beta = \frac{I_C}{I_B} = \frac{5 \text{ mA}}{40 \mu\text{A}} = 125$$

9.4.4 Transistor as a switch

The transistor in saturation and cut-off regions functions like an electronic switch that helps to turn ON or OFF a given circuit by a small control signal. The circuit is shown in Figure 9.34.

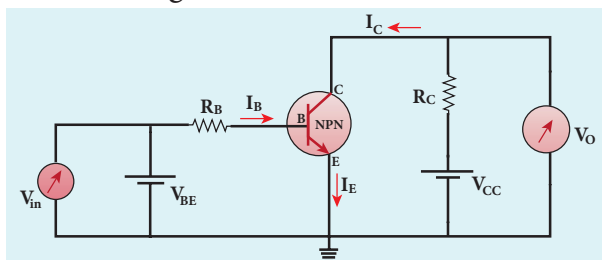

Figure 9.34 Transistor as a switch

• Presence of dc source at the input (saturation region):

When a high input voltage ($V_{in} = +5\text{V}$) is applied, the base current (I_B) increases and in turn increases the collector current. The transistor will move into the saturation region (turned ON). The increase in collector current (I_C) increases the voltage drop across R_C , thereby lowering the output voltage, close to zero. The transistor acts like a closed switch and is equivalent to ON condition.

• Absence of dc source at the input (cut-off region):

A low input voltage ($V_{in} = 0\text{V}$), decreases the base current (I_B) and in turn decreases the collector current (I_C). The transistor will move into the cut-off region (turned OFF). The decrease in collector current (I_C) decreases the drop across R_C , thereby increasing the output voltage, close to +5 V. The transistor acts as an open switch which is considered as the OFF condition.

It is manifested that, a high input gives a low output and a low input gives a high output. In addition, we can say that the output voltage is opposite to the applied input voltage. Therefore, a transistor can be used as an inverter (NOT gate) in computer logic circuitry.

9.4.5 Operating Point

The operating point is a point where the transistor can be operated efficiently. A line that is drawn with the values V_{CC} (when $I_C = 0$) and I_C (when $V_{CE} = 0$) is called the dc load line. The dc load line superimposed on the output characteristics of a transistor is used to learn the operating point of the transistor as shown in Figure 9.35.

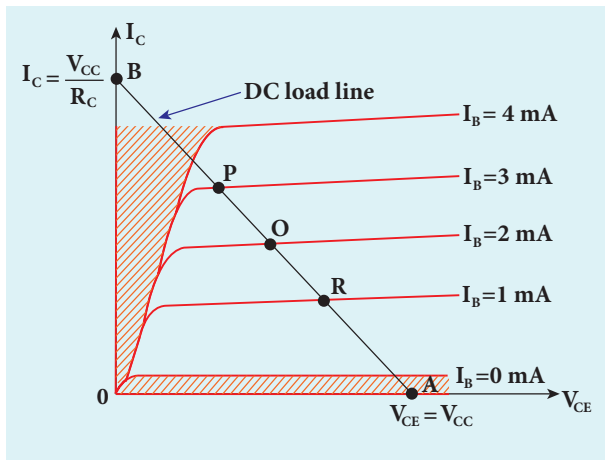

Figure 9.35 Output characteristics of a transistor in common emitter mode with the dc load line

Points P, Q, R in Figure 9.35 are called Q points or quiescent points which determine the operating point or the working point of a transistor. If the operating point is chosen at the middle of the dc load line (point Q), the transistor can effectively work as an amplifier. The operating point determines the maximum signal that can be obtained without being distorted.

For a transistor to work as an open switch, the Q point can be chosen at the cut-off region and to work as a closed switch, the Q point can be chosen in the saturation region.

EXAMPLE:9.8

The current gain of a common emitter transistor circuit shown in figure is 120. Draw the dc load line and mark the Q point on it. (V_{BE} to be ignored).

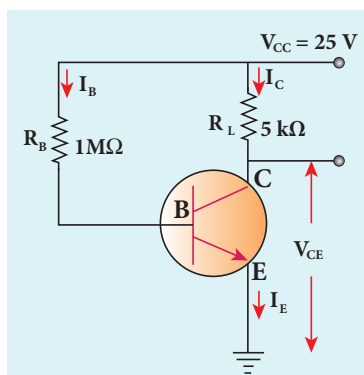

Solution

$$\beta = 120$$

$$\text{Base current } I_B = \frac{25V}{1M\Omega} = \frac{25}{1 \times 10^6} = 25 \mu A$$

$$\beta = \frac{I_C}{I_B}$$

$$I_C = \beta I_B$$

$$I_C = 120 \times 25 \mu A$$

$$I_C = 3mA$$

$$V_{CE} = V_{CC} - I_C R_C$$

$$V_{CE} = 25 - 3mA \times 5k$$

$$V_{CE} = 10V$$

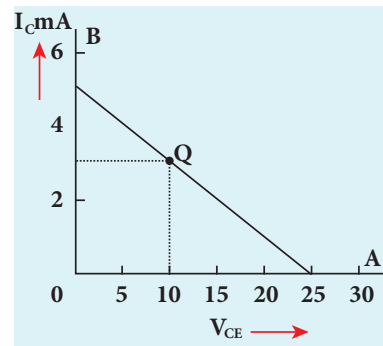

9.4.6 Transistor as an amplifier

A transistor operating in the active region has the capability to amplify weak signals. **Amplification is the process of increasing the signal strength (increase in the amplitude).** If a large amplification is required, the transistors are cascaded with coupling elements like resistors, capacitors, and transformers which is called as multistage amplifiers.

Here, the amplification of an electrical signal is explained with a single stage transistor amplifier as shown in Figure 9.36(a). Single stage indicates that the circuit consists of one transistor with the allied components. An NPN transistor

is connected in the common emitter configuration.

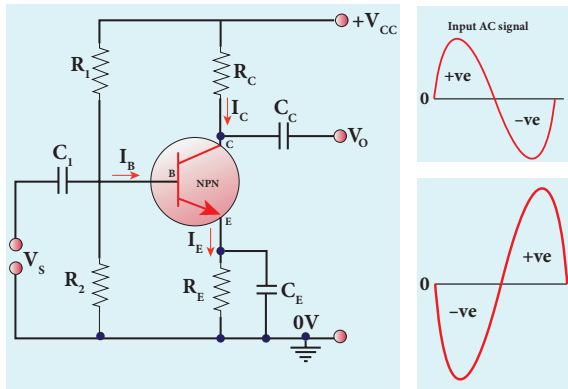

Figure 9.36 (a) Transistor as an amplifier (b) Input and output waveform showing 180° phase reversal.

To start with, the Q point or the operating point of the transistor is fixed so as to get the maximum signal swing at the output (neither towards saturation point nor towards cut-off). A load resistance, R_C is connected in series with the collector circuit to measure the output voltage. The capacitor C_1 allows only the ac signal to pass through. The emitter bypass capacitor C_E provides a low reactance path to the amplified ac signal. The coupling capacitor C_C is used to couple one stage of the amplifier with the next stage while constructing multistage amplifiers. V_S is the sinusoidal input signal source applied across the base-emitter. The output is taken across the collector-emitter.

$$\text{Collector current, } I_C = \beta I_B \left[\because \beta = \frac{I_C}{I_B} \right]$$

Applying Kirchhoff's voltage law in the output loop, the collector-emitter voltage is given by

$$V_{CE} = V_{CC} - I_C R_C$$

Working of the amplifier

- *During the positive half cycle*

Input signal (V_S) increases the forward voltage across the emitter-base. As a

result, the base current (I_B) increases. Consequently, the collector current (I_C) increases β times. This increases the voltage drop across R_C ($I_C R_C$) which in turn decreases the collector-emitter voltage (V_{CE}). Therefore, the input signal in the positive direction produces an amplified signal in the negative direction at the output. Hence, the output signal is reversed by 180° as shown in Figure 9.36(b).

- *During the negative half cycle*

Input signal (V_S) decreases the forward voltage across the emitter-base. As a result, base current (I_B) decreases and in turn increases the collector current (I_C). The increase in collector current (I_C) decreases the potential drop across R_C and increases the collector-emitter voltage (V_{CE}). Thus, the input signal in the negative direction produces an amplified signal in the positive direction at the output. Therefore, 180° phase reversal is observed during the negative half cycle of the input signal as well as shown in Figure 9.36(b).

9.4.7 Transistor as an oscillator

An **electronic oscillator** basically converts dc energy into ac energy of high frequency ranging from a few Hz to several MHz. Hence, it is a source of alternating current or voltage. Unlike an amplifier, oscillator does not require any external signal source.

Basically, there are two types of oscillators: **Sinusoidal and non-sinusoidal**. Sinusoidal oscillators generate oscillations in the form of sine waves at constant amplitude and frequency as shown in Figure 9.37(a). Whereas non-sinusoidal oscillators generate complex non-sinusoidal waveforms like

Square-wave, Triangular-wave or Sawtooth-wave as shown in Figure 9.36(b).

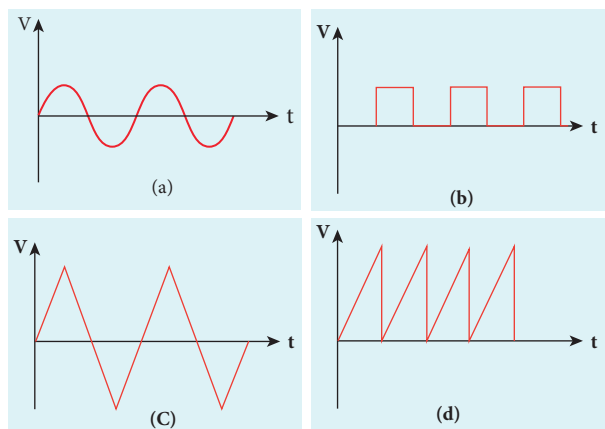

Figure 9.37 (a) sinusoidal waveform
(b) square waveform (c) ramp waveform
(d) triangular waveform

Sinusoidal oscillations can be of two types: **Damped and undamped.** If the amplitude of the electrical oscillations decreases with time due to energy loss, it is called damped oscillations as shown in Figure 9.38(a). On the other hand, the amplitude of the electrical oscillations remains constant with time in undamped oscillations as shown in Figure 9.38(b).

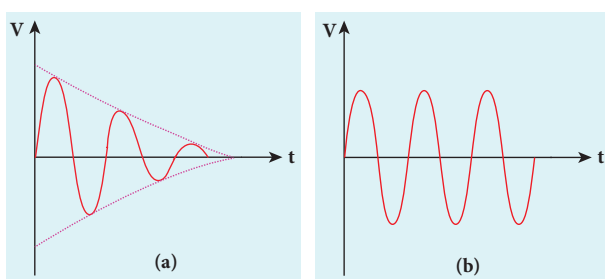

Figure 9.38 (a) Damped oscillations
(b) Undamped oscillations

Transistor Oscillator

An oscillator circuit consists of a tank circuit, an amplifier and a feedback circuit as shown in Figure 9.39. The tank circuit generates electrical oscillations and acts as the ac input source to the transistor amplifier. Amplifier amplifies the input ac signal. The

feedback circuit provides a portion of the output to the tank circuit to sustain the oscillations without energy loss. Hence, an oscillator does not require an external input signal. The output is said to be self-sustained.

Amplifier

The transistor amplifier circuit is already explained in section {9.4.5}.

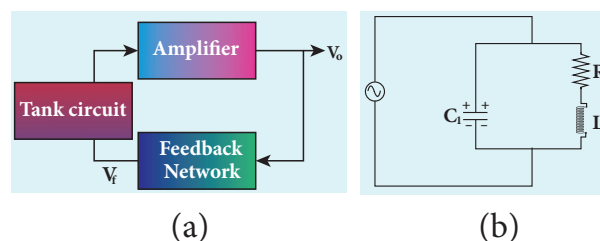

Figure 9.39 (a) Block diagram of an oscillator (b) tank circuit

Feedback network

The circuit used to feedback a portion of the output to the input is called the feedback network. If the portion of the output fed to the input is in phase with the input, then the magnitude of the input signal increases. It is necessary for sustained oscillations.

Tank circuit

The LC tank circuit consists of an inductance and a capacitor connected in parallel as shown in Figure 9.39. Whenever energy is supplied to the tank circuit from a DC source, the energy is stored in inductor and capacitor alternatively. This produces electrical oscillations of definite frequency. (Refer section 4.9.1, Volume 1 of XII std. Physics text book)

But in practical oscillator circuits there will be loss of energy across resistors, inductor coils and capacitors. A small amount of energy is used up in overcoming these losses during every cycle of charging and discharging of the capacitor. Due to this, the amplitude of the oscillations decreases

gradually. Hence, the tank circuit produces damped electrical oscillations. Therefore, in order to produce undamped oscillations, a positive feedback is provided from the output circuit to the input circuit.

The frequency of oscillations is determined by the values of L and C using the equation.

$$f = \frac{1}{2\pi\sqrt{LC}}$$

Barkhausen conditions for sustained oscillations

The following condition called Barkhausen conditions should be satisfied for sustained oscillations in the oscillator.

- The loop phase shift must be 0° or integral multiples of 2π .
- The loop gain must be unity. $|A\beta|=1$

Here, A → Voltage gain of the amplifier,
 β → feedback ratio; (fraction of the output that is fed back to the input)

There are different types of oscillator circuits based on the different types of tank circuits. Examples: Hartley oscillator, Colpitt's oscillator, Phase shift oscillator, and Crystal oscillator.

Applications of oscillators

- to generate a periodic sinusoidal or non sinusoidal wave forms
- to generate RF carriers
- to generate audio tones
- to generate clock signal in digital circuits
- as sweep circuits in TV sets and CRO

EXAMPLE 9.9

Calculate the range of the variable capacitor that is to be used in a tuned-collector oscillator which has a fixed inductance of $150 \mu\text{H}$. The frequency band is from 500 kHz to 1500 kHz.

$$\text{Resonant frequency, } f_o = \frac{1}{2\pi\sqrt{LC}}$$

$$\text{On simplifying we get } C = \frac{1}{4\pi^2 f_o^2 L}$$

When frequency is equal to 500 kHz

$$C = \frac{1}{4 \times 3.14^2 \times (500 \times 10^3)^2 \times 150 \times 10^{-6}} \\ = 676 \text{ pF}$$

When frequency is equal to 1500 kHz

$$C = \frac{1}{4 \times 3.14^2 \times (1500 \times 10^3)^2 \times 150 \times 10^{-6}} \\ = 75 \text{ pF}$$

Therefore, the capacitor range is 75 – 676 pF

9.5

DIGITAL ELECTRONICS

Digital Electronics is the sub-branch of electronics which deals with digital signals. It is increasingly used in numerous applications ranging from high end processor circuits to miniature circuits for signal processing, communication etc. Digital signals are preferred than analog signals due to their better performance, accuracy, speed, flexibility, and immunity to noise.

9.5.1 Analog and Digital Signals

There are 2 different types of signals used in Electronics. They are (i) Analog signals and (ii) Digital signals. An analog signal is a continuously varying voltage or current with respect to time. Such signals have been employed in rectifying circuits and transistor amplifier circuits.

Digital signals are signals which contain only discrete values of voltages. Digital signals need two states: switch ON and OFF.

ON is considered as one state and OFF is considered as the other state. It can also be defined as high (ON) or low (OFF) state, closed (ON) or open (OFF). These high and low states are defined using binary numbers 1 or 0 in Boolean Algebra. The state 1 represents the terms: circuit on, high voltage, a closed switch. Similarly a 0 state represents circuit off, low voltage or an open switch.

Positive and Negative Logic

In digital systems, there exists two voltage levels: 5V (high) and 0V (low). In a positive logic system; a binary 1 stands for 5V and 0 stands for 0V while in negative logic system, 1 state for 0V and 0 state for 5V as shown in Figure 9.40.

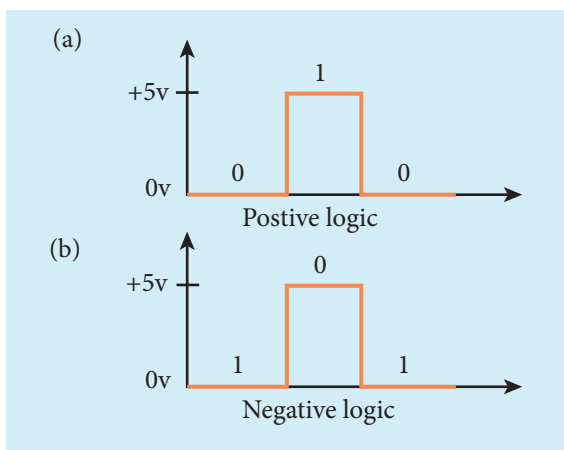

Figure 9.40 (a) Positive (b) Negative logics

9.5.2 Logic gates

A logic gate is an electronic circuit which functions based on digital signals. The logic gates are considered as the basic building blocks of most of the digital systems. It has one output with one or more inputs. There are three types of basic logic gates: AND, OR, and NOT. The other logic gates are Ex-OR, NAND, and NOR. They can be constructed from the basic logic gates.

Digital electronics deals with logical operations. The variables are called logical variables. The operators like logical addition (+) and logical multiplication (\cdot) are called logical operators. When the logical operators (+, \cdot) operate on logical variables (A, B), it gives logical constant (Y). The equation that represents this operation is called logical statement.

For example,

Logical operator: +

Logical variable: A, B

Logical constant: Y

Logical Statement: $Y = A + B$

The possible combinations of inputs and the corresponding output is given in table called truth table. The circuits which perform the basic logical operations such as logical addition, multiplication and inversion are discussed below.

AND gate

Circuit symbol

The circuit symbol of a two input AND gate is shown in Figure 9.41(a). A and B are inputs and Y is the output. It is a logic gate and hence A, B, and Y can have the value of either 1 or 0.

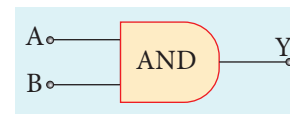

(a)

Inputs		Output
A	B	$Y = A + B$
0	0	0
0	1	0
1	0	0
1	1	1

(b)

Figure 9.41 (a) Two input AND gate (b) Truth Table

Boolean equation:

$$Y = A \cdot B$$

It performs logical multiplication and is different from arithmetic multiplication.

Logic operation

The output of AND gate is high (1) only when all the inputs are high (1). The rest of the cases the output is low. Hence the output of AND gate is high (1) only when all the inputs are high. It is represented in the truth table (Figure 9.41(b)).

OR gate

Circuit Symbol

The circuit symbol of a two input OR gate is shown in Figure 9.42(a). A and B are inputs and Y is the output.

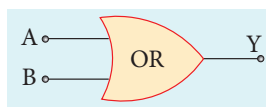

(a)

Inputs		Output
A	B	$Y = A + B$
0	0	0
0	1	1
1	0	1
1	1	1

(b)

Figure 9.42 (a) Two input OR gate
(b) Truth Table

Boolean equation:

$$Y = A + B$$

It performs logical addition and is different from arithmetic addition.

Logic operation

The output of OR gate is high (logic 1 state) when either of the inputs or both are high. The truth table of OR gate is shown in Figure 9.42(b).

NOT gate

Circuit symbol

The circuit symbol of NOT gate is shown in Figure 9.43(a). A is the input and Y is the output.

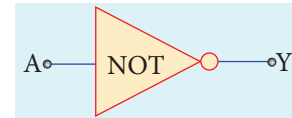

(a)

Inputs		Output
A		$Y = \bar{A}$
0		1
1		0

(b)

Figure 9.43 (a) NOT gate (b) Truth Table

Boolean equation

$$Y = \bar{A}$$

Logic operation

The output is the complement of the input. It is represented with an overbar. It is also called as inverter. The truth table infers that the output Y is 1 when input A is 0 and vice versa. The truth table of NOT is shown in Figure 9.43(b).

NAND gate

The circuit symbol of NAND gate is shown in Figure 9.44(a). A and B are inputs and Y is the output.

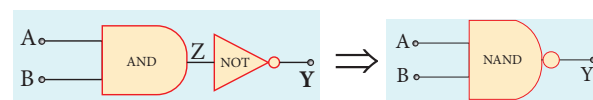

(a)

Input		Output (AND)	Output (NAND)
A	B	$Z = A \cdot B$	$Y = \overline{A \cdot B}$
0	0	0	1
0	1	0	1
1	0	0	1
1	1	1	0

(b)

Figure 9.44 (a) Two input NAND gate
(b) Truth Table

Boolean equation

$$Y = \overline{A \cdot B}$$

Logic operation

The output Y equals the complement of AND operation. The circuit is an AND gate followed by a NOT gate. Therefore, it is summarized as NAND. The output is at logic zero only when all the inputs are high. The rest of the cases, the output is high (Logic 1 state). The truth table of NAND gate is shown in Figure 9.44(b).

NOR gate

Circuit symbol

The circuit symbol of NOR gate is shown in Figure 9.45(a). A and B are inputs and Y is the output.

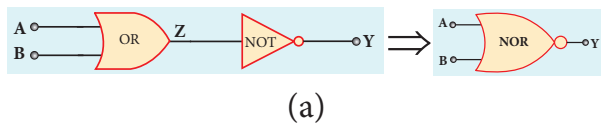

Inputs		Output (OR)	Output (NOR)
A	B	$Z = A + B$	$Y = \overline{A + B}$
0	0	0	1
0	1	1	0
1	0	1	0
1	1	1	0

(b)

Figure: 9.45 (a) NOR gate (b) Truth Table

Boolean equation

$$Y = \overline{A + B}$$

Logic operation

Y equals the complement of OR operation (A OR B). The circuit is an OR gate followed by a NOT gate and is summarized as NOR.

The output is high when all the inputs are low. The output is low for all other combinations of inputs. The truth table of NOR gate is shown in Figure 9.45(b).

Ex-OR gate

Circuit symbol

The circuit symbol of Ex-OR gate is shown in Figure 9.46(a). A and B are inputs and Y is the output. The Ex-OR operation is denoted as \oplus .

Boolean equation

$$Y = A \cdot \overline{B} + \overline{A} \cdot B$$

$$Y = A \oplus B$$

Logic operation

The output is high only when either of the two inputs is high. In the case of an Ex-OR gate with more than two inputs, the output will be high when odd number of inputs are high. The truth table of Ex-OR gate is shown in Figure 9.46(b).

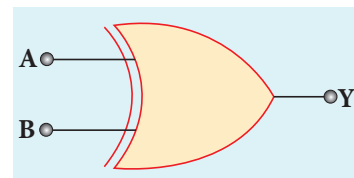

(a)

Inputs		Output (Ex-OR)
A	B	$Y = A \oplus B$
0	0	0
0	1	1
1	0	1
1	1	0

(b)

Figure 9.46 (a) Ex-OR gate (b) Truth Table

EXAMPLE 9.10

What is the output Y in the following circuit, when all the three inputs A, B, and C are first 0 and then 1?

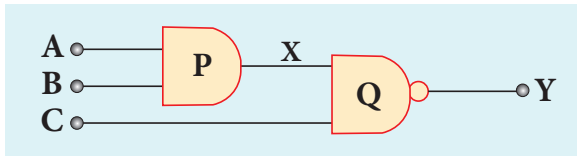

Solution

A	B	C	$X = A \cdot B$	$Y = \overline{X \cdot C}$
0	0	0	0	1
1	1	1	1	0

EXAMPLE 9.11

In the combination of the following gates, write the Boolean equation for output Y in terms of inputs A and B.

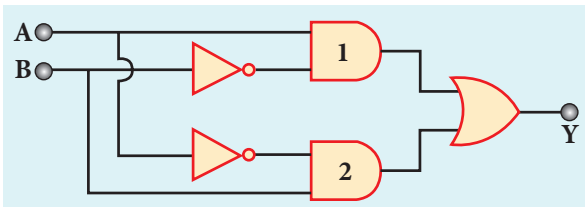

Solution

The output at the 1st AND gate: $\overline{A}B$

The output at the 2nd AND gate: $A\overline{B}$

The output at the OR gate: $Y = \overline{A}B + A\overline{B}$

9.6

BOOLEAN ALGEBRA

Boolean Algebra is basically a choice between two options (i) yes or no (ii) high or low. These two options in Boolean algebra are represented by binary numbers 0 or 1. It is a concept that relates logic and mathematics which is a century old, made up by George

Boole in 1854. Later the importance of Boolean algebra was realized in the design of computer circuits. Today we are in a digital world and most of the comforts that we experience is due to digitization with the foundation based on Boolean algebra.



The concept of high (1) and low (0) is not a new one. In fact, it was applied in telephone switching circuits by Shannon in 1938.

Laws of Boolean Algebra

The NOT, OR and AND operations discussed in 9.5.2 are the Boolean operations. The results of these operations can be summarised as:

Complement law

A	$Y = \overline{\overline{A}}$
0	$Y = \overline{0} = 1$
1	$Y = \overline{1} = 0$

The complement law can be realised as $\overline{\overline{A}} = A$

OR laws

A	B	$Y = A + B$
0	0	$Y = 0 + 0 = 0$
0	1	$Y = 0 + 1 = 1$
1	0	$Y = 1 + 0 = 1$
1	1	$Y = 1 + 1 = 1$

The OR laws can be realised as

1 st law	$A + 0 = A$
2 nd law	$A + 1 = 1$
3 rd law	$A + A = A$
4 th law	$A + \overline{A} = 1$

AND laws

A	B	$Y = A.B$
0	0	$Y = 0.0 = 0$
0	1	$Y = 0.1 = 0$
1	0	$Y = 1.0 = 0$
1	1	$Y = 1.1 = 1$

The AND laws can be realised as

1 st law	$A . 0 = 0$
2 nd law	$A . 1 = A$
3 rd law	$A . A = A$
4 th law	$A . \bar{A} = 0$

The Boolean operations obey the following laws.

Commutative laws

$$A + B = B + A$$

$$A . B = B . A$$

Associative laws

$$A + (B + C) = (A + B) + C$$

$$A . (B . C) = (A . B) . C$$

Distributive laws

$$A(B + C) = AB + AC$$

$$A + BC = (A + B)(A + C)$$

The above laws are used to simplify complicated expressions and to simplify the logic circuitry.

9.7

DE MORGAN'S THEOREM

9.7.1 De Morgan's First Theorem

The first theorem states that the complement of the sum of two logical inputs is equal to the product of its complements.

Proof

The Boolean equation for NOR gate is $Y = \overline{A + B}$

The Boolean equation for a bubbled AND gate is $Y = \overline{A . B}$

Both cases generate same outputs for same inputs. It can be verified using the following truth table.

A	B	$A+B$	$\overline{A+B}$	\bar{A}	\bar{B}	$\overline{A . B}$
0	0	0	1	1	1	1
0	1	1	0	1	0	0
1	0	1	0	0	1	0
1	1	1	0	0	0	0

From the above truth table, we can conclude $\overline{A + B} = \bar{A} . \bar{B}$.

Thus De Morgan's First Theorem is proved. It also says that a NOR gate is equal to a bubbled AND gate.

The corresponding logic circuit diagram is shown in Figure 9.47.

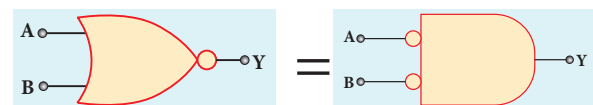

Figure 9.47 NOR gate equals bubbled AND gate

9.7.2 De Morgan's Second Theorem

The second theorem states that the complement of the product of two inputs is equal to the sum of its complements.

Proof

The Boolean equation for NAND gate is $Y = \overline{A . B}$

The Boolean equation for bubbled OR gate is $Y = \overline{\bar{A} + \bar{B}}$



A and B are the inputs and Y is the output. The above two equations produces the same output for the same inputs. It can be verified by using the truth table

A	B	A.B	$\overline{A.B}$	\overline{A}	\overline{B}	$\overline{A+B}$
0	0	0	1	1	1	1
0	1	0	1	1	0	1
1	0	0	1	0	1	1
1	1	1	0	0	0	0

From the above truth table we can conclude $\overline{A.B} = \overline{A+B}$

Thus De Morgan's First Theorem is proved. It also says, a NAND gate is equal to a bubbled OR gate.

The corresponding logic circuit diagram is shown in Figure 9.48

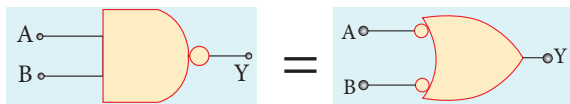

Figure 9.48 NAND gate equals bubbled OR gate

EXAMPLE:9.12

Simplify the Boolean identity

$$AC + ABC = AC$$

Solution

Step 1: $AC(1 + B) = AC.1$ [OR law-2]

Step 2: $AC . 1 = AC$ [AND law - 2]

Therefore, $AC + ABC = AC$

Circuit Description

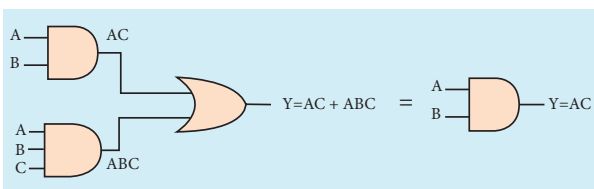

Thus the given statement is proved.

9.7.3 Integrated Chips

An integrated circuit is also referred as an IC or a chip or a microchip (Figure 9.49). It consists of thousands to millions of transistors, resistors, capacitors, etc. integrated on a small flat piece of semiconductor material that is normally Silicon.

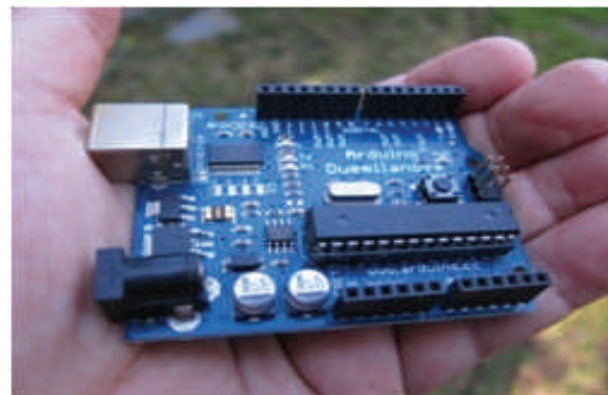

Figure 9.49 Circuits with integrated chips

Integrated circuits (ICs) are the keystone of modern electronics. With the advancement in technology and the emergence of Very Large Scale Integration (VLSI) era it is possible to fit more and more transistors on chips of same piece.

ICs have two main advantages over ordinary circuits: cost and performance. The size, speed, and capacity of chips have progressed enormously with the advancement in technology. Computers, mobile phones, and other digital home

appliances are now made possible by the small size and low cost of ICs. ICs can function as an amplifier, oscillator, timer, microprocessor and computer memory.

These extremely small ICs can perform calculations and store data using either digital or analog technology. Digital ICs use logic gates, which work only with values of ones and zeros. A low signal sent to a component on a digital IC will result in a

value of 0, while a high signal creates a value of 1.

Digital ICs usually find their applications in computers, networking equipment, and most consumer electronics. **Analog ICs** or linear ICs work with continuous values. This means a component on a linear IC can take any value and output another value. Linear ICs are typically used in audio and radio frequency amplification.

SUMMARY

- Energy bands in solids are used to classify them into metals, insulators, and semiconductors
- In a N-type semiconductor, electrons are the majority charge carriers and holes are the minority carriers
- In P-type semiconductor, holes are the majority charge carriers and electrons are the minority charge carriers
- A depletion region is formed in an unbiased PN junction. It is devoid of mobile charge carriers. Instead, it has immobile ions
- When a PN junction diode is forward biased, the depletion region decreases and the diode conducts once after the barrier potential is crossed. It acts like a closed switch.
- A PN junction diode in reverse biased condition functions as an open switch as it does not conduct. The depletion region increases.
- A forward biased PN junction diode functions as a rectifier. Rectification is the process of converting an AC current into DC current
- The half wave rectifier rectifies one half of the input signal and produces a pulsating output.
- Full wave rectifier rectifies both halves of the input signal.
- The efficiency of the full wave rectifier is two times the efficiency of the half wave rectifier
- The two mechanisms that are responsible for breakdown under increasing reverse voltage: Zener and Avalanche breakdown
- Zener breakdown happens in a heavily doped PN junction diode when a strong electric field is applied.
- Avalanche breakdown occurs in lightly doped junctions which have wide depletion layers. It is due to the breaking of covalent bonds by the thermally generated minority charge carriers.



- Zener diode is a heavily doped PN junction diode works in the reverse biased direction
- Light emitting diode is a forward biased semiconductor device that emits visible or invisible light when energized. The recombination of minority charge carriers with the majority charge carriers in the respective regions release energy in the form of Photons.
- A PN junction diode made of photosensitive material converts an optical signal into electric signal is called a photodiode.
- When a photon of sufficient energy strikes the diode, it creates an electron-hole pair. These electrons and holes are swept across the p-n junction by the electric field created by reverse voltage before recombination takes place and in turn generates photo current.
- A solar cell is an electrical device that converts the energy of light directly into electricity by the photovoltaic effect.
- A bipolar junction transistor is a semiconductor device is of two types: NPN and PNP.
- BJT has three regions: emitter, base, and collector
- To operate the transistor in the active region, emitter base must be forward biased and collector base must be reverse biased.
- A BJT can be operated in three different configurations: Common base, common emitter, common collector.
- The forward current gain in common base configuration α gives the ratio of the collector current to emitter current.
- The forward current gain in common emitter configuration β gives the ratio of the collector current to the base current
- The BJT connected in common emitter configuration functions as a switch
- The BJT connected in common emitter configuration can be used as an amplifier. There exists a phase reversal of 180° between the input signal and the amplified output signal.
- A transistor amplifier combined with a tank circuit and positive feedback acts as an oscillator
- The logic gates are logical circuits provides output only for a combination of inputs.
- The basic logic gates are AND, OR, and NOT gates.
- Boolean algebra is used to simplify complicated expressions and hence to simplify the logic circuit.
- De Morgan's First theorem states that the complement of the sum of two inputs is equal to the product of its complements.
- The second theorem states that the complement of the product of two inputs is equal to the sum of its complements.



CONCEPT MAP

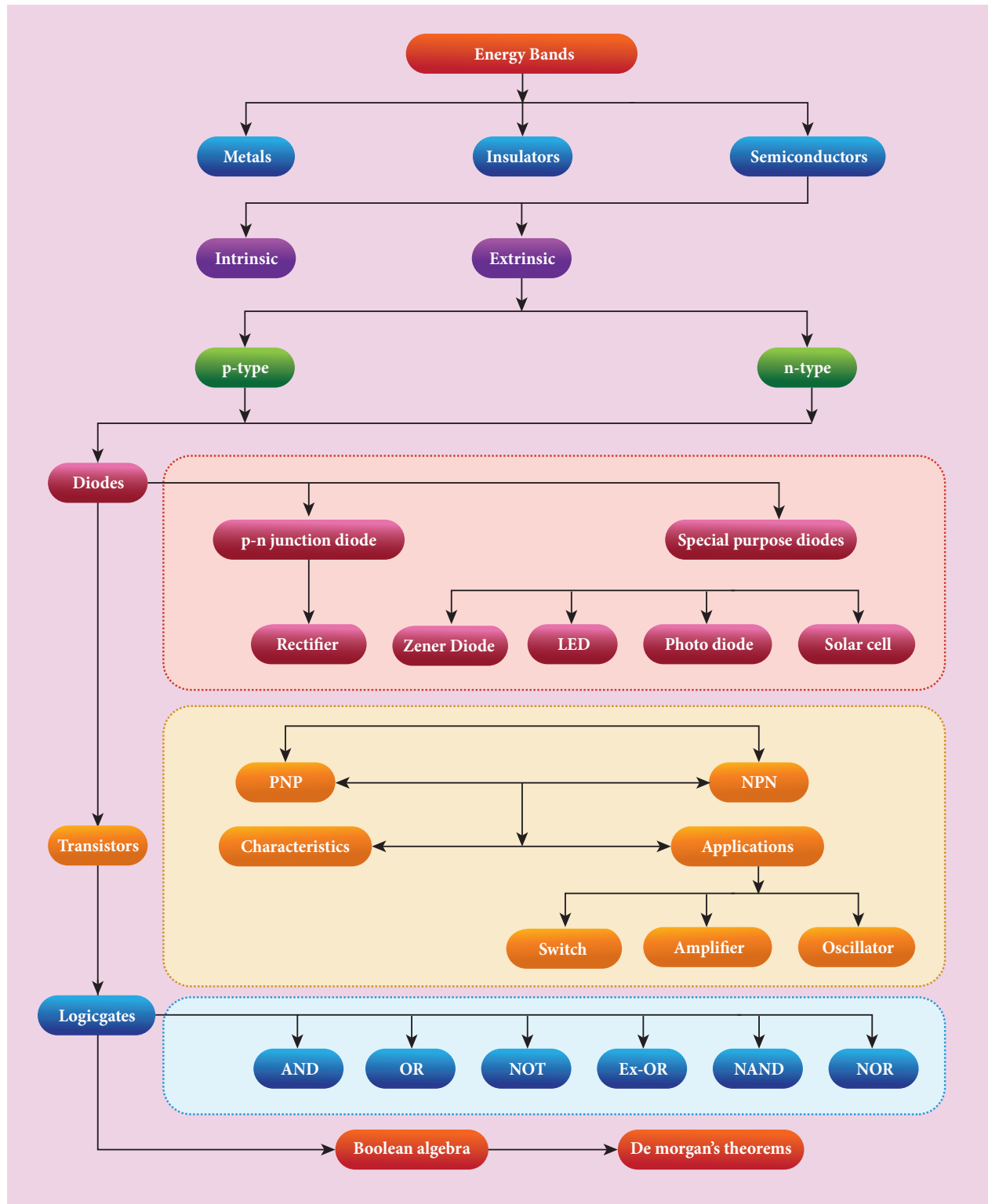



EVALUATION



I. Multiple choice questions

- The barrier potential of a silicon diode is approximately,
 - 0.7 V
 - 0.3V
 - 2.0 V
 - 2.2V
- Doping a semiconductor results in
 - The decrease in mobile charge carriers
 - The change in chemical properties
 - The change in the crystal structure
 - The breaking of the covalent bond
- A forward biased diode is treated as
 - An open switch with infinite resistance
 - A closed switch with a voltage drop of 0V
 - A closed switch in series with a battery voltage of 0.7V
 - A closed switch in series with a small resistance and a battery.
- If a half-wave rectified voltage is fed to a load resistor, which part of a cycle the load current will flow?
 - $0^\circ-90^\circ$
 - $90^\circ-180^\circ$
 - $0^\circ-180^\circ$
 - $0^\circ-360^\circ$
- The primary use of a zener diode is
 - Rectifier
 - Amplifier
 - Oscillator
 - Voltage regulator
- The principle in which a solar cell operates
 - Diffusion
 - Recombination
 - Photovoltaic action
 - Carrier flow
- The light emitted in an LED is due to
 - Recombination of charge carriers
 - Reflection of light due to lens action
 - Amplification of light falling at the junction
 - Large current capacity.
- When a transistor is fully switched on, it is said to be
 - Shorted
 - Saturated
 - Cut-off
 - Open
- The specific characteristic of a common emitter amplifier is
 - High input resistance
 - Low power gain
 - Signal phase reversal
 - Low current gain
- To obtain sustained oscillation in an oscillator,
 - Feedback should be positive
 - Feedback factor must be unity
 - Phase shift must be 0 or 2π
 - All the above
- If the input to the NOT gate is A = 1011, its output is
 - 0100
 - 1000
 - 1100
 - 0011
- The electrical series circuit in digital form is
 - AND
 - OR
 - NOR
 - NAND



13. Which one of the following represents forward bias diode? (NEET)

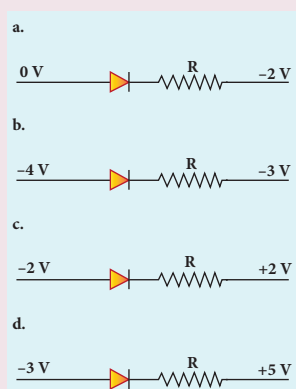

14. The given electrical network is equivalent to (NEET)

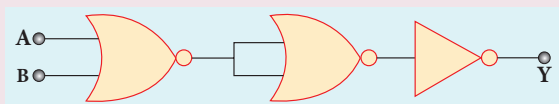

- a. AND gate
b. OR gate
c. NOR gate
d. NOT gate
15. The output of the following circuit is 1 when the input ABC is (NEET 2016)

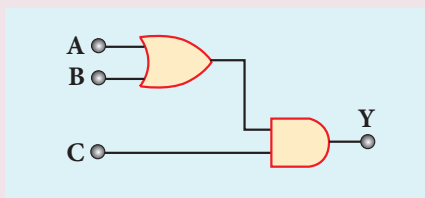

- a. 101
b. 100
c. 110
d. 010

Answers

1. a 2. c 3. d 4. c 5. d
6. c 7. a 8. b 9. c 10. d
11. a 12. a 13. a 14. c 15. a

II. Short Answer Questions

- Define electron motion in a semiconductor.
- Distinguish between intrinsic and extrinsic semiconductors.
- What do you mean by doping?
- How electron-hole pairs are created in a semiconductor material?
- A diode is called as a unidirectional device. Explain
- What do you mean by leakage current in a diode?
- Draw the output waveform of a full wave rectifier.
- Distinguish between avalanche and zener breakdown.
- Discuss the biasing polarities in an NPN and PNP transistors.
- Explain the current flow in a NPN transistor
- What is the phase relationship between the AC input and output voltages in a common emitter amplifier? What is the reason for the phase reversal?
- Explain the need for a feedback circuit in a transistor oscillator.
- Give circuit symbol, logical operation, truth table, and Boolean expression of AND, OR, NOT, NAND, NOR, and EX-OR gates
- State De Morgan's first and second theorems.

III. Long Answer Questions

- Elucidate the formation of a N-type and P-type semiconductors.
- Explain the formation of PN junction diode. Discuss its V-I characteristics.

- Draw the circuit diagram of a half wave rectifier and explain its working
- Explain the construction and working of a full wave rectifier.
- What is an LED? Give the principle of operation with a diagram.
- Write notes on Photodiode.
- Explain the working principle of a solar cell. Mention its applications.
- Sketch the static characteristics of a common emitter transistor and bring out the essence of input and output characteristics.
- Describe the function of a transistor as an amplifier with the neat circuit diagram. Sketch the input and output wave form.
- Transistor functions as a switch. Explain.
- State Boolean laws. Elucidate how they are used to simplify Boolean expressions with suitable example.
- State and prove De Morgan's First and Second theorems.

IV. Numerical Problems

- The given circuit has two ideal diodes connected as shown in figure below. Calculate the current flowing through the resistance R_1 [Ans: 2.5 A]

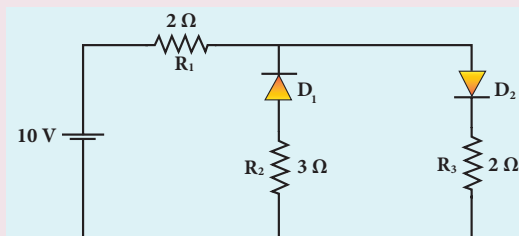

- Four silicon diodes and a $10\ \Omega$ resistor are connected as shown in figure below. Each diode has a resistance of $1\ \Omega$. Find the current flows through the $18\ \Omega$ resistor. [Ans: 0.13 A]

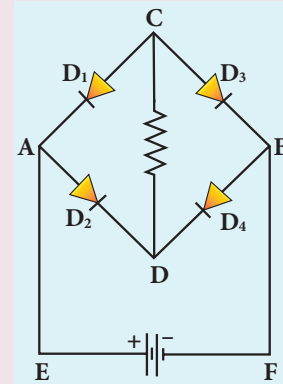

- Assuming $V_{CEsat} = 0.2\ \text{V}$ and $\beta = 50$, find the minimum base current (I_B) required to drive the transistor given in the figure to saturation. [Ans: $56\ \mu\text{A}$]

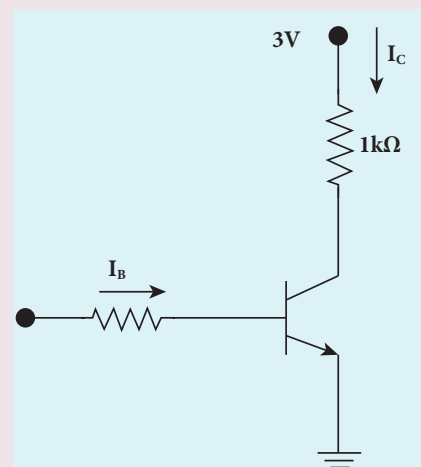

4. A transistor having $\alpha = 0.99$ and $V_{BE} = 0.7V$, is given in the circuit. Find the value of the collector current.

[Ans: 5.33 mA]

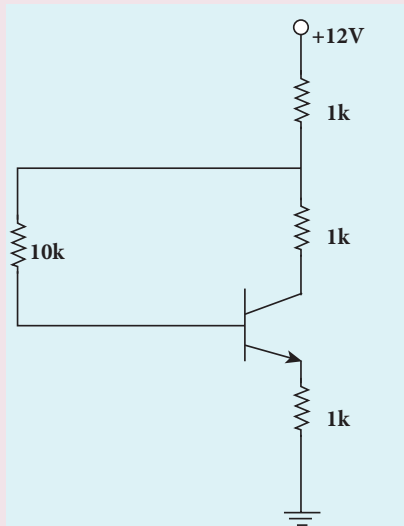

5. In the circuit shown in the figure, the BJT has a current gain (β) of 50. For an emitter - base voltage $V_{EB} = 600$ mV, calculate the emitter - collector voltage V_{EC} (in volts).

[Ans: 2 V]

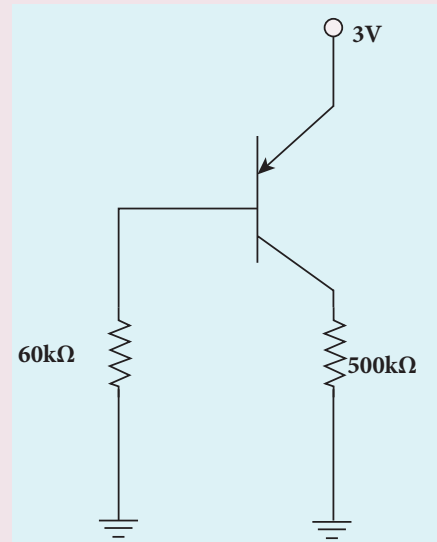

BOOK FOR REFERENCES

1. Charles Kittel , *Introduction to Solid State Physics*, John Wiley & Sons, 2012
2. Rita John, *Solid State Physics*, McGraw Hill Education, 2016
3. Robert L. Boylestad, Louis Nashelsky, *Electronic Devices and Circuit Theory* , Pearson Prentice Hall, 2011
4. Jacob Millman, Christos Halkias, Chetan Parikh, *Millman's Integrated Electronics*, McGraw Hill Education, 2017
5. B.L.Theraja, R.S. Sedha, *Principles of Electronics Devices and Circuits (Analog and Digital)*, S. Chand & Company, 2011
6. Albert Paul Malvino, Donald P. Leach, Goutam Saha, *Digital principles and applications*, McGraw Hill Education, 2014
7. V.K.Metha, Rohit Metha, *Principles of Electronics*, S. Chand & Company, 2010.



ICT CORNER

Semiconductor electronics

In this activity you will be able to
(i) Construct , manipulate and simulate the logic circuits. (ii) verify the truth tables of AND, OR, NOT, EX-OR, NAND and NOR gates

Topic: Logic gates

STEPS:

- Open the browser and type “circuitverse.org/simulator” in the address bar.
- Click ‘Gates’ tab from the circuit elements. Select the gate you want to verify and drag it in to the stage.
- Nodes in the logic gates are connected through wires. Wires can be drawn by dragging from the nodes with the help of mouse.
- Select ‘input tool’ from input tab. Drag and keep it as two inputs.
- Select ‘output tool’ or ‘digital LED’ from output tab. Drag and keep it as output.
- Verify the truth tables of AND, OR, NOT, EX-OR, NAND and NOR gates. You can verify De Morgan’s first and second theorems.

Step1

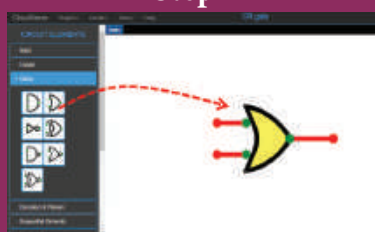

Step2

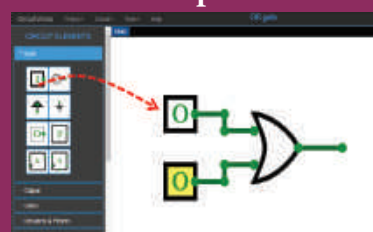

Step3

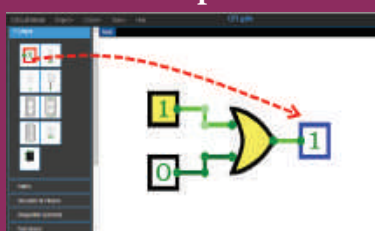

Step4

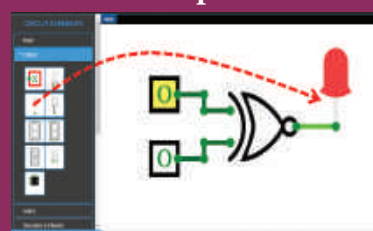

Note:

Login with the help of your mail id if you want to save your project in online.

URL:

<https://circuitverse.org/simulator>

* Pictures are indicative only.

* If browser requires, allow **Flash Player** or **Java Script** to load the page.



B263_12_PHYSICS_EM

UNIT 10

COMMUNICATION SYSTEMS

Good communication is the bridge between confusion and clarity

– Nat Turner

In this unit, the students are exposed to

- Basic elements of communication system
- Need for modulation and its types
- Propagation of electromagnetic waves through space
- Satellite communication
- Fiber optic communication
- RADAR
- Internet
- Global positioning system
- Applications of communication technology in fishing, mining, and agriculture sectors.



10.1

INTRODUCTION

Communication exists since the dawn of life in this world. Growth in science and technology removed the locational disadvantage effectively. Information can be exchanged from one person to another anywhere on this Earth. Right from the developments made in communication by great scientists like J.C. Bose, G. Marconi, and Alexander Graham Bell, communication has witnessed leaps and bounds. The communication industry is one of the largest in size and is the oldest since communication through telegraph (1844), telephone (1876), and Radio (1887) started centuries back. The intensive research in the mid- and late nineteenth century leads to the development of long-distance transmission in

the shortest possible time. However, the 20th century witnessed a leap over the development of communication, meeting the demands of speed and secured transfer of data. Every sector in the world is experiencing a significant profit with the advent of Global Positioning System (GPS), satellite, mobile, and optical communications. This unit provides a glimpse of the basic concepts of electronic communication and its applications.

10.2

MODULATION

The transmission of information through short distances does not require complicated techniques. The energy of the information signal is sufficient enough to be sent directly. However if the information, for example, audio frequency (20 to 20,000 Hz) needs to

be transmitted to long distances across the world, certain techniques are required to transmit the information without any loss.

For long distance transmission, the low frequency baseband signal (input signal) is superimposed onto a high frequency radio signal by a process called modulation. In the modulation process, a very high frequency signal called carrier signal (radio signal) is used to carry the baseband signal.

As the frequency of the carrier signal is very high, it can be transmitted to long distances with less attenuation. The carrier signal is usually a sine wave signal. Also, the carrier signal will be more compatible with the communication medium like free space and can propagate with greater efficiency.



Note Carrier signal does not have information.

A sinusoidal carrier wave can be represented as $e_c = E_c \sin(2\pi\nu_c t + \phi)$, where E_c is the amplitude, ν_c is the frequency and ϕ is the initial phase of the carrier wave at any instant of time t .

Three characteristics in the carrier signal can be modified by the baseband signal during the process of modulation: amplitude, frequency and phase of the carrier signal.

There are 3 types of modulation based on which parameter is modified. They are (i) amplitude modulation, (ii) frequency modulation and (iii) phase modulation.

10.2.1 AMPLITUDE MODULATION (AM)

If the amplitude of the carrier signal is modified in proportion to the instantaneous amplitude of the baseband

signal, then it is called amplitude modulation. Here the frequency and the phase of the carrier signal remain constant. Amplitude modulation is used in radio and TV broadcasting.

The signal shown in Figure 10.1(a) is the baseband signal that carries information. Figure 10.1(b) shows the high-frequency carrier signal and Figure 10.1(c) gives amplitude modulated signal. We can see that amplitude of the carrier is modified in proportion to the amplitude of the baseband signal.

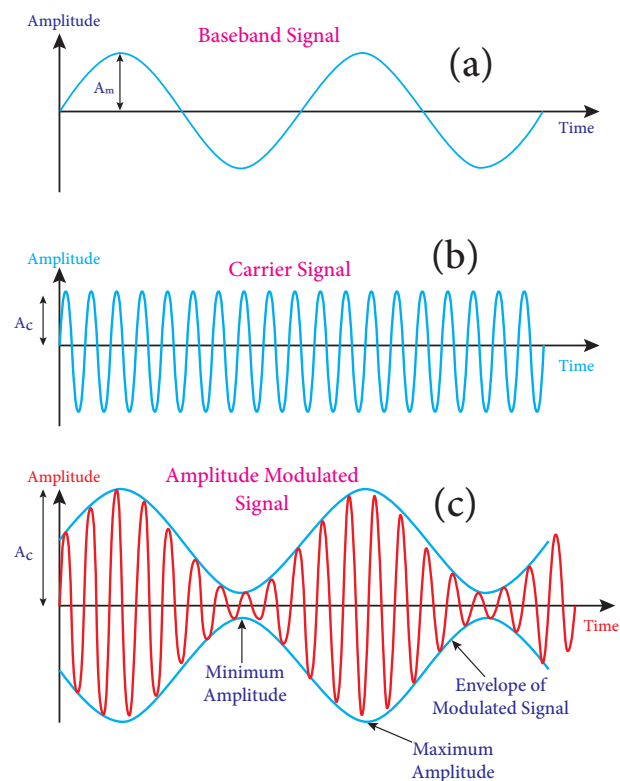

Figure 10.1 Amplitude Modulation
(a) baseband signal (b) carrier signal
(c) modulated signal

Advantages of AM

- i) Easy transmission and reception
- ii) Lesser bandwidth requirements
- iii) Low cost

Limitations of AM

- i) Noise level is high
- ii) Low efficiency
- iii) Small operating range



10.2.2 FREQUENCY MODULATION (FM)

The frequency of the carrier signal is modified in proportion to the instantaneous amplitude of the baseband signal in frequency modulation. Here the amplitude and the phase of the carrier signal remain constant. Increase in the amplitude of the baseband signal increases the frequency of the carrier signal and vice versa. This leads to compressions and rarefactions in the frequency spectrum of the modulated wave as shown in Figure 10.2. Louder signal leads to compressions and relatively weaker signals to rarefactions.

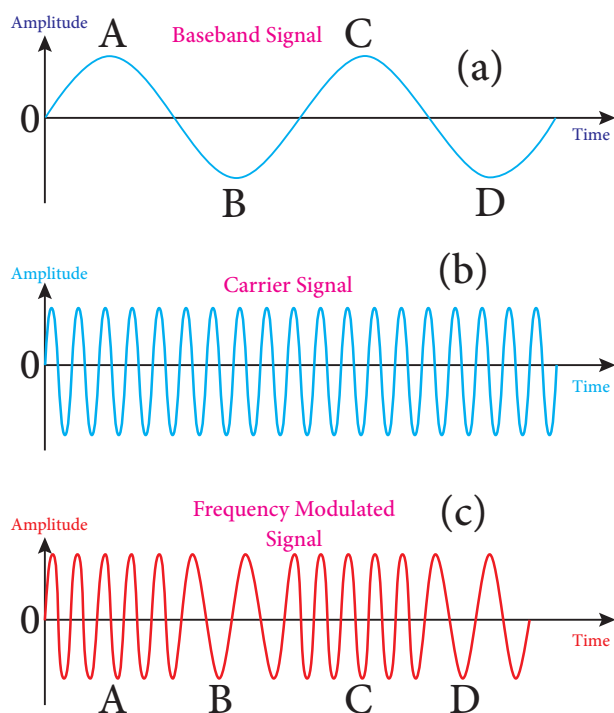

Figure 10.2 Frequency Modulation
(a) baseband signal (b) carrier signal
(c) frequency modulated signal

When the amplitude of the baseband signal is zero in Figure 10.2(a), the frequency of the modulated signal is the same as the carrier signal. The frequency of the modulated wave increases when the amplitude of the baseband signal increases

in the positive direction (A, C). The increase in amplitude in the negative half cycle (B, D) reduces the frequency of the modulated wave (Figure 10.2(c)).

When the frequency of the baseband signal is zero (no input signal), there is no change in the frequency of the carrier wave. It is at its normal frequency and is called as **centre frequency or resting frequency**. Practically this is the allotted frequency of the FM transmitter.

Advantages of FM

- Large decrease in noise. This leads to an increase in signal-noise ratio.
- The operating range is quite large.
- The transmission efficiency is very high as all the transmitted power is useful.
- FM bandwidth covers the entire frequency range which humans can hear. Due to this, FM radio has better quality compared to AM radio.

Limitations of FM

- FM requires a much wider channel.
- FM transmitters and receivers are more complex and costly.
- In FM reception, less area is covered compared to AM.

10.2.3 PHASE MODULATION (PM)

In phase modulation, the instantaneous amplitude of the baseband signal modifies the phase of the carrier signal keeping the amplitude and frequency constant (Figure 10.3). This modulation is used to generate frequency modulated signals. It is similar to frequency modulation except that the phase of the carrier is varied instead of varying frequency.

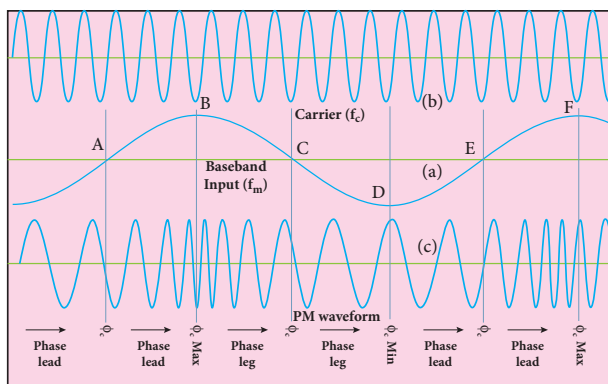

Figure 10.3 Phase Modulation
 (a) carrier signal (b) baseband signal
 (c) phase modulated signal

The carrier phase changes according to increase or decrease in the amplitude of the baseband signal. When the modulating signal goes positive, the amount of phase lead increases with the amplitude of the modulating signal. Due to this, the carrier signal is compressed or its frequency is increased.

On the other hand, the negative half cycle of the baseband signal produces a phase lag in the carrier signal. This appears to have stretched the frequency of the carrier wave. Hence similar to frequency modulated wave, phase modulated wave also comprises of compressions and rarefactions. When the signal voltage is zero (A, C and E) the carrier frequency is unchanged.

The frequency shift in carrier wave frequency exists in phase modulation as well. The frequency shift depends on (i) amplitude of the modulating signal and (ii) the frequency of the signal.



Note

- If a square wave is used as the baseband signal, then phase reversal takes place in the modulated signal.
- FM and PM waves are completely different for square wave modulating signal.

Advantages of PM

- i) FM signal produced from PM signal is very stable.
- ii) The centre frequency called resting frequency is extremely stable.



Comparison between FM and PM

PM wave is similar to FM wave. PM generally uses a smaller bandwidth than FM. In other words, in PM, more information can be sent in a given bandwidth. Hence, phase modulation provides high transmission speed on a given bandwidth.

10.3

THE ELEMENTS OF AN ELECTRONIC COMMUNICATION SYSTEM

Electronics plays a major role in communication. Electronic communication is nothing but the transmission of sound, text, pictures, or data through a medium. Long distance transmission uses free space as a medium. This section provides sufficient information on how voice signal is transmitted by a transmitter through space and received by the receiver at the receiving end.

Elements of an electronic communication system

The elements of the basic communication system are explained with the block diagram shown in Figure 10.4.

1. Information (Baseband or input signal)

Information can be in the form of speech, music, pictures, or computer data.

This information is given as input to the input transducer.

2. Input transducer

A transducer is a device that converts variations in a physical quantity (pressure, temperature, sound) into an equivalent electrical signal or vice versa. In communication system, the transducer converts the information which is in the form of sound, music, pictures or computer data into corresponding electrical signals. **The electrical equivalent of the original information is called the baseband signal.** The best example for the transducer is the microphone that converts sound energy into electrical energy.

3. Transmitter

It feeds the electrical signal from the transducer to the communication channel. It consists of circuits such as amplifier,

oscillator, modulator and power amplifier. The transmitter is located at the broadcasting station.

Amplifier: The transducer output is very weak and is amplified by the amplifier.

Oscillator: It generates high-frequency carrier wave (a sinusoidal wave) for long distance transmission into space. As the energy of a wave is proportional to its frequency, the carrier wave has very high energy.

Modulator: It superimposes the baseband signal onto the carrier signal and generates the modulated signal.

Power amplifier: It increases the power level of the electrical signal in order to cover a large distance.

4. Transmitting antenna

It radiates the radio signal into space in all directions. It travels in the form of electromagnetic waves with the velocity of light ($3 \times 10^8 \text{ m s}^{-1}$).

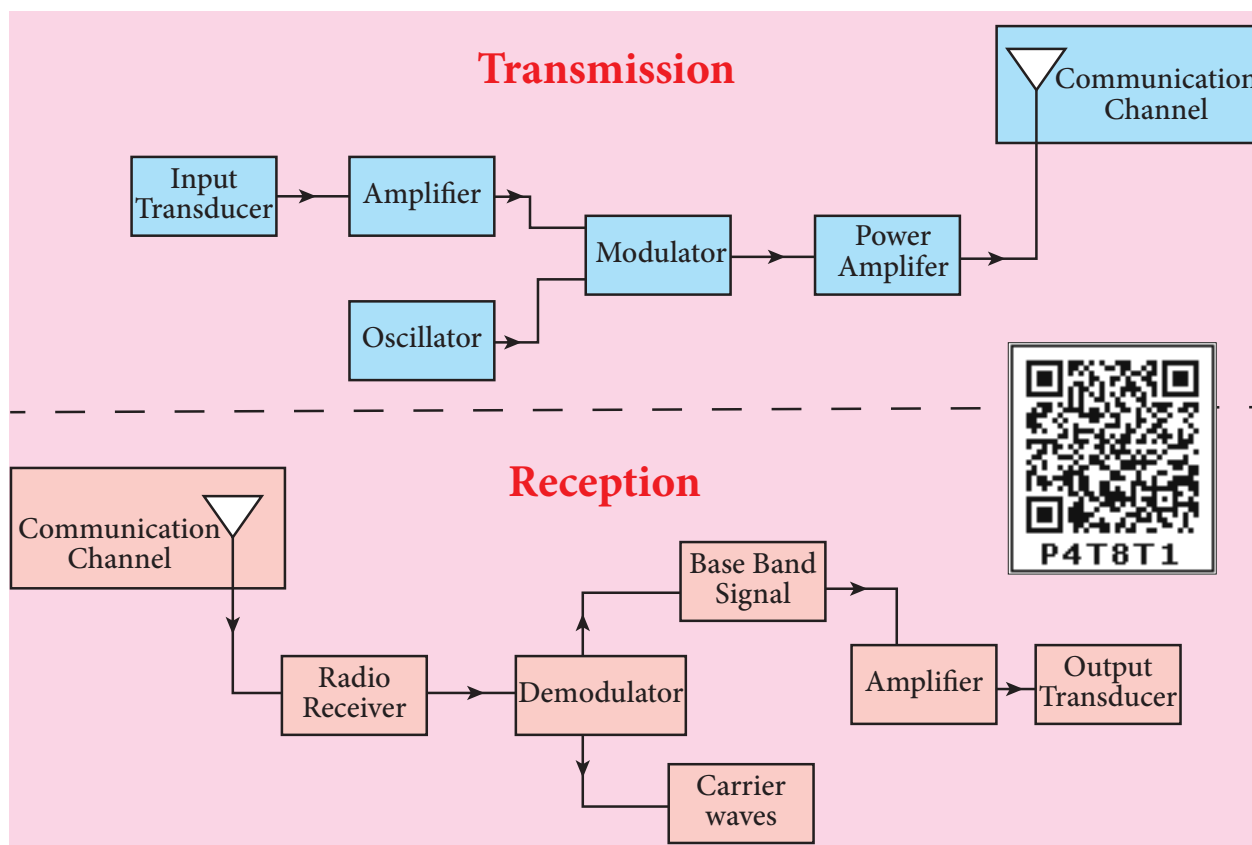

Figure 10.4 Block diagram of transmission and reception of voice signals

5. Communication channel

Communication channel is used to carry the electrical signal from transmitter to receiver with less noise or distortion. The communication medium is basically of two types: wireline communication and wireless communication.

Wireline communication (point to point communication) uses mediums like wires, cables and optical fibers. These systems cannot be used for long distance transmission as they are connected physically. Examples are telephone, intercom and cable TV.

Wireless communication uses free space as a communication medium. The signals are transmitted in the form of electromagnetic waves with the help of a transmitting antenna. Hence wireless communication is used for long distance transmission. Examples are mobile, radio or TV broadcasting and satellite communication.

6. Noise

It is the undesirable electrical signal that interferes with the transmitted signal. Noise attenuates or reduces the quality of the transmitted signal. It may be man-made (automobiles, welding machines, electric motors etc.) or natural (lightning, radiation from sun and stars and environmental effects). Noise cannot be completely eliminated. However, it can be reduced using various techniques.

7. Receiver

The signals that are transmitted through the communication medium are received by a receiving antenna which converts em waves into RF signals and are fed into the receiver. The receiver consists of electronic circuits like demodulator, amplifier, detector etc. The demodulator extracts the baseband

signal from the modulated signal. Then the baseband signal is detected and amplified using amplifiers. Finally, it is fed to the output transducer.

8. Repeaters

Repeaters are used to increase the range or distance through which the signals are sent. It is a combination of transmitter and receiver. The signals are received, amplified and retransmitted with a carrier signal of different frequency to the destination. The best example is the communication satellite in space.

9. Output transducer

It converts the electrical signal back to its original form such as sound, music, pictures or data. Examples of output transducers are loudspeakers, picture tubes, computer monitor, etc.

10. Attenuation

The loss of strength of a signal while propagating through a medium is known as attenuation.

11. Range

It is the maximum distance between the source and the destination up to which the signal is received with sufficient strength.

10.3.1 BANDWIDTH

The frequency range over which the baseband signals or the information signals such as voice, music, picture etc is transmitted is known as bandwidth. Each of these signals has different frequencies.

The type of communication system depends on the nature of the frequency band for a given signal. Bandwidth gives the difference between the upper and lower frequency limits of the signal. It can also be defined as the portion of the electromagnetic

spectrum occupied by the signal. If ν_1 and ν_2 are the lower and upper-frequency limits of a signal, then the bandwidth, $BW = \nu_2 - \nu_1$.

10.3.2 BANDWIDTH OF TRANSMISSION SYSTEM

The range of frequencies required to transmit a piece of specified information in a particular channel is called **channel bandwidth** or the **bandwidth of the transmission system**. This corresponds to the spectrum that is assigned to be used by the system. For example, amplitude modulation system requires a channel bandwidth of 10 kHz to transmit a 5 kHz signal, whereas a single side-band system requires only a 5 kHz channel bandwidth for the same 5 kHz signal. This is because in amplitude modulation, the channel bandwidth is twice the signal frequency. Therefore, it is required to reduce the channel bandwidth to accommodate more number of channels in the available electromagnetic spectrum. In some applications, modulation is selected based on this.

10.4

ANTENNA SIZE

Antenna is used at both transmitter and receiver end. Antenna height is an important parameter to be discussed. The height of the antenna must be a multiple of $\frac{\lambda}{4}$.

$$h = \frac{\lambda}{4} \quad (10.1)$$

where λ is wavelength ($\lambda = \frac{c}{\nu}$), c is the velocity of light and ν is the frequency of the signal to be transmitted.

An example

Let us consider two baseband signals. One signal is modulated and the other is not modulated.

The frequency of the original baseband signal is taken as $\nu = 10 \text{ kHz}$ while the modulated signal is $\nu = 1 \text{ MHz}$.

The height of the antenna required to transmit the original baseband signal of frequency $\nu = 10 \text{ kHz}$ is

$$h_1 = \frac{\lambda}{4} = \frac{c}{4\nu} = \frac{3 \times 10^8}{4 \times 10 \times 10^3} = 7.5 \text{ km} \quad (10.2)$$

The height of the antenna required to transmit the modulated signal of frequency $\nu = 1 \text{ MHz}$ is

$$h_2 = \frac{\lambda}{4} = \frac{c}{4\nu} = \frac{3 \times 10^8}{4 \times 1 \times 10^6} = 75 \text{ m} \quad (10.3)$$

Comparing equations (10.2) and (10.3), we can infer that it is practically feasible to construct an antenna of height 75 m while the one with 7.5 km is not possible. It clearly manifests that modulated signals reduce the antenna height and are required for long distance transmission.

10.5

PROPAGATION OF ELECTROMAGNETIC WAVES

The information signal modulated with the carrier wave (radio wave) is transmitted by an antenna. This travels through space and is received by the receiving antenna at the other end. The frequencies from 2 kHz to 400 GHz are transmitted through wireless communication. The strength of the electromagnetic wave keeps decreasing while traveling from transmitter to the receiver. The electromagnetic wave

transmitted by the transmitter travels in three different modes to reach the receiver according to its frequency range:

- Ground wave propagation (or) surface wave propagation (nearly 2 kHz to 2 MHz)
- Sky wave propagation (or) ionospheric propagation (nearly 3 MHz to 30 MHz)
- Space wave propagation (nearly 30 MHz to 400 GHz)

10.5.1 GROUND WAVE PROPAGATION

If the electromagnetic waves transmitted by the transmitter glide over the surface of the earth to reach the receiver, then the propagation is called ground wave propagation. The corresponding waves are called ground waves or surface waves. The pictorial representation is shown in Figure 10.5(a).

Both transmitting and receiving antennas must be close to the earth. The size of the antenna plays a major role in deciding the efficiency of the radiation of signals.

During transmission, the electrical signals are attenuated over a distance. Some reasons for attenuation are as follows:

- **Increasing distance:** The attenuation of the signal with distance depends on (i) power of the transmitter (ii) frequency of the transmitter and (iii) condition of the Earth surface.
- **Absorption of energy by the Earth:** When the transmitted signal in the form of EM wave is in contact with the Earth, it induces charges in the Earth and constitutes a current. Due to this, the Earth behaves like a leaky capacitor

which leads to the attenuation of the wave.

- **Tilting of the wave:** As the wave progresses, the wavefront starts gradually tilting according to the curvature of the Earth. This increase in the tilt decreases the electric field strength of the wave. Finally at some distance, the surface wave dies out due to energy loss.

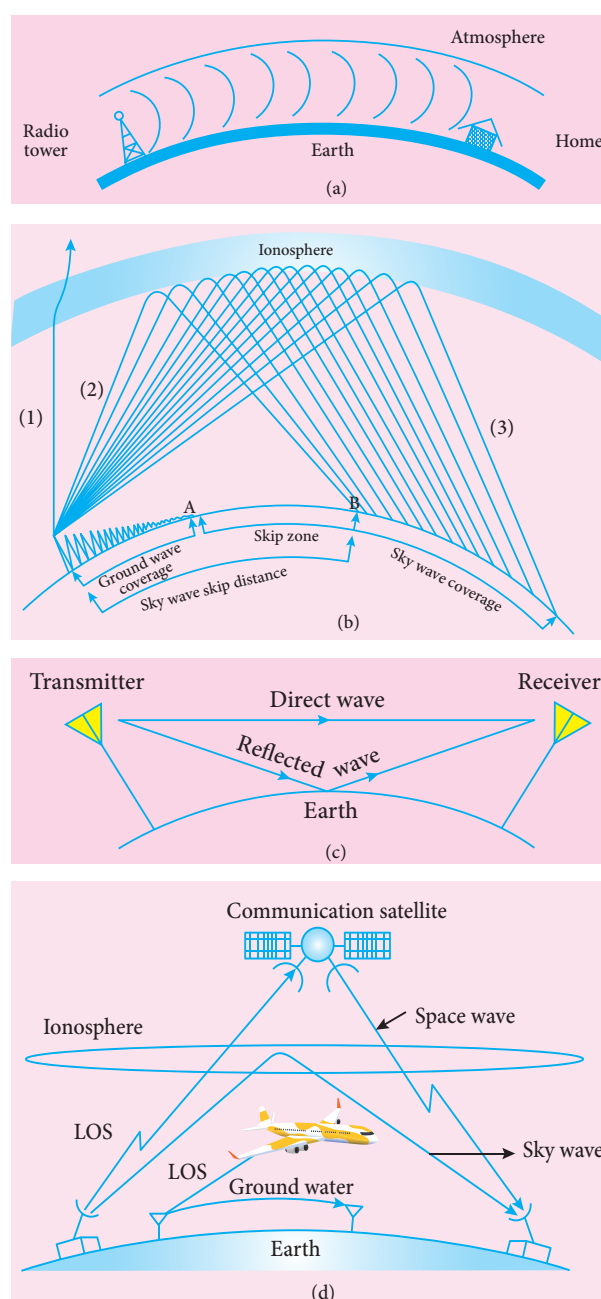

Figure 10.5 Propagation of EM waves (a) Ground wave (b) Sky wave (c) Space wave (d) Summary of all modes of propagation



The frequency of the ground waves is mostly less than 2 MHz as high frequency waves undergo more absorption of energy at the earth's atmosphere. The medium wave signals received during the day time use surface wave propagation.

It is mainly used in local broadcasting, radio navigation, for ship-to-ship, ship-to-shore communication and mobile communication.

10.5.2 SKY WAVE PROPAGATION

The mode of propagation in which the electromagnetic waves radiated from an antenna, directed upwards at large angles, gets reflected by the ionosphere back to earth is called sky wave propagation or ionospheric propagation. The corresponding waves are called sky waves (Figure 10.5(b)).

The frequency range of EM waves in this mode of propagation is 3 to 30 MHz. EM waves of frequency more than 30 MHz can easily penetrate through the ionosphere and does not undergo reflection. It is used for short wave broadcast services. Medium and high frequencies are for long-distance radio communication. Extremely long-distance communication is also possible as the radio waves can undergo multiple reflections between the earth and the ionosphere. A single reflection helps the radio waves to travel a distance of approximately 4000 km.

Ionosphere acts as a reflecting surface. It is at a distance of approximately 50 km and spreads up to 400 km above the Earth surface. Due to the absorption of

ultraviolet rays, cosmic ray, and other high energy radiations like α , β rays from sun, the air molecules in the ionosphere get ionized. This produces charged ions and these ions provide a reflecting medium for the reflection of radio waves or communication waves back to Earth within the permitted frequency range. The phenomenon of bending the radio waves back to earth is nothing but the total internal reflection.

This is the reason why the EM waves are transmitted at a critical angle to ensure that the waves undergo total reflection and reaches the ground without escaping into space.

The shortest distance between the transmitter and the point of reception of the sky wave along the surface is called as the skip distance shown in Figure 10.5(b).

The electromagnetic waves are transmitted from the ground at particular angles. When the angle of emission increases, the reception of ground waves decreases. At one point, there will be no reception due to ground waves and marked as A in the Figure 10.5(b).

If the angle of emission is increased further, the reception of sky waves starts at point B in the Figure 10.5(b). **There is a zone (in between A and B) where there is no reception of electromagnetic waves neither ground nor sky, called as skip zone or skip area.**



The higher the frequency, higher is the skip distance and for a frequency less than the critical frequency, skip distance is zero.



10.5.3 SPACE WAVE PROPAGATION

The process of sending and receiving information signal through space is called space wave communication (Figure 10.5(c)). The electromagnetic waves of very high frequencies above 30 MHz are called as space waves. These waves travel in a straight line from the transmitter to the receiver. Hence, it is used for a line of sight communication (LOS).

For high frequencies, the transmission towers must be high enough so that the transmitted and received signals (direct waves) will not encounter the curvature of the Earth and hence travel with less attenuation and loss of signal strength. Certain waves reach the receiver after getting reflected from the ground.

The communication systems like television telecast, satellite communication and RADAR are based on space wave propagation. Microwaves having high frequencies (super high frequency band) are used against radio waves due to certain advantages: larger bandwidth, high data rates, better directivity, small antenna size, low power consumption, etc.

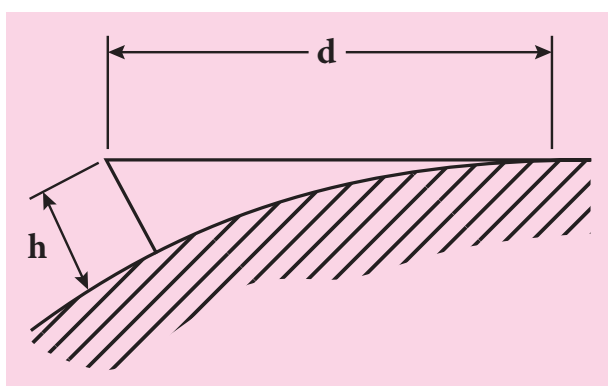

Figure 10.6 Distance of coverage

The range or distance (d) of coverage of the propagation depends on the height (h) of the antenna given by the equation,

$$d = \sqrt{2Rh} \quad (10.4)$$

where R is the radius of the Earth and it is 6400 km.

The distance of coverage is shown pictorially in Figure 10.6.

EXAMPLE 10.1

A transmitting antenna has a height of 40 m and the height of the receiving antenna is 30 m. What is the maximum distance between them for line-of-sight communication? The radius of the earth is 6.4×10^6 m.

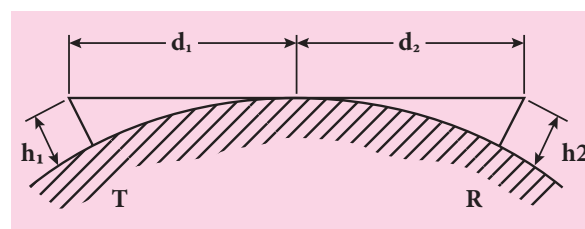

Solution:

The total distance d between the transmitting and receiving antennas will be the sum of the individual distances of coverage.

$$\begin{aligned} d &= d_1 + d_2 \\ &= \sqrt{2Rh_1} + \sqrt{2Rh_2} \\ &= \sqrt{2R} (\sqrt{h_1} + \sqrt{h_2}) \\ &= \sqrt{2 \times 6.4 \times 10^6} \times (\sqrt{40} + \sqrt{30}) \\ &= 16 \times 10^2 \sqrt{5} \times (6.32 + 5.48) \\ &= 42217 \text{ m} = 42.217 \text{ km} \end{aligned}$$

10.6

SATELLITE COMMUNICATION

The satellite communication is a mode of communication of signal between transmitter and receiver via satellite. The message signal from the Earth station is transmitted to the satellite on board via an uplink (frequency band 6 GHz), amplified by a transponder and then retransmitted to another Earth station via a downlink (frequency band 4 GHz) (Figure 10.7).

The high-frequency radio wave signals travel in a straight line (line of sight) may come across tall buildings or mountains or even encounter the curvature of the earth. A communication satellite relays and amplifies such radio signals via transponder to reach distant and far off places using uplinks and downlinks. It is also called as a radio repeater in sky. The applications are found to be in all fields and are discussed below.

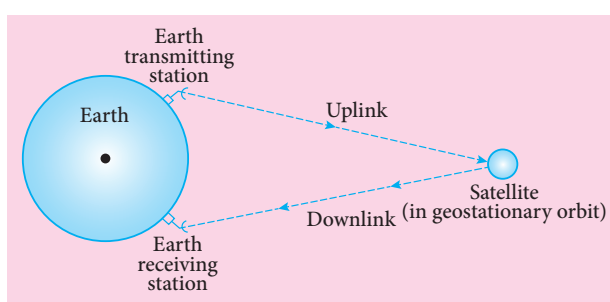

Figure 10.7 Satellite communication system

Applications

Satellites are classified into different types based on their applications. Some satellites are discussed below.

- i) **Weather Satellites:** They are used to monitor the weather and climate of Earth. By measuring cloud mass, these satellites enable us to predict rain and dangerous storms like hurricanes, cyclones etc.
- ii) **Communication satellites:** They are used to transmit television, radio, internet signals etc. Multiple satellites are used for long distances.
- iii) **Navigation satellites:** These are employed to determine the geographic location of ships, aircrafts or any other object.

10.7

FIBRE OPTIC COMMUNICATION

The method of transmitting information from one place to another in terms of light pulses through an optical fiber is called fiber optic communication. It works under the principle of total internal reflection.

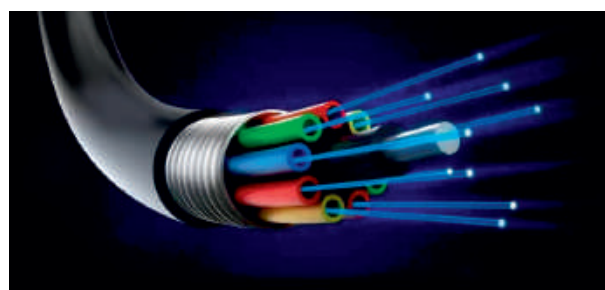

Figure 10.8 Optical fibers

Light has very high frequency (400 THz – 790 THz) than microwave radio systems. The fibers are made up of silica glass or silicon dioxide which is highly abundant on Earth.

Now it has been replaced with materials such as chalcogenide glasses, fluoroaluminate crystalline materials because they provide larger infrared wavelength and better transmission capability.

As fibers are not electrically conductive, it is preferred in places where multiple channels are to be laid and isolation is required from electrical and electromagnetic interference.

Applications

Optical fiber system has a number of applications namely, international communication, inter-city communication, data links, plant and traffic control and defense applications.

Merits

- i) Fiber cables are very thin and weigh lesser than copper cables.
- ii) This system has much larger band width. This means that its information carrying capacity is larger.
- iii) Fiber optic system is immune to electrical interferences.
- iv) Fiber optic cables are cheaper than copper cables.

Demerits

- i) Fiber optic cables are more fragile when compared to copper wires.
- ii) It is an expensive technology.



Fiber optic cables provide the fastest transmission rate compared to any other form of transmission. It can provide data speed of 1 Gbps for homes and business. Multimode fibers operate at the speed of 10 Mbps. Recent developments in optical communication provide the data speed at the rate of 25 Gbps



Most transatlantic telecommunication cables between the United States of America and Europe are fiber optic.

10.8

RADAR AND APPLICATIONS

Radar basically stands for Radio Detection and Ranging System. It is one of the important applications of communication systems and is mainly used to sense, detect, and locate distant objects like aircraft, ships, spacecraft, etc. The angle, range or velocity of the objects that are invisible to the human eye can be determined.

Radar uses electromagnetic waves for communication. The electromagnetic signal is initially radiated into space by an antenna in all directions. When this signal strikes the targeted object, it gets reflected or reradiated in many directions. This reflected (echo) signal is received by the radar antenna which in turn is delivered to the receiver. Then, it is processed and amplified to determine the geographical statistics of the object. The range is determined by calculating the time taken by the signal to travel from RADAR to the target and back.

Applications

Radars find extensive applications in almost all fields. A few are mentioned below.

- i) In military, it is used for locating and detecting the targets.
- ii) It is used in navigation systems such as ship borne surface search, air search and missile guidance systems.

- iii) To measure precipitation rate and wind speed in meteorological observations, Radars are used.
- iv) It is employed to locate and rescue people in emergency situations.

10.9

MOBILE COMMUNICATION

Mobile communication is used to communicate with others in different locations without the use of any physical connection like wires or cables. It allows the transmission over a wide range of area without the use of the physical link. It enables the people to communicate with each other regardless of a particular location like office, house etc. It also provides communication access to remote areas.



Figure 10.9 Mobile communication

It provides the facility of roaming – that is, the user may move from one place to another without the need of compromising on the communication. The maintenance and cost of installation of this communication network are also cheap.

Applications

- i) It is used for personal communication and cellular phones offer voice and data connectivity with high speed.

- ii) Transmission of news across the globe is done within a few seconds.
- iii) Using Internet of Things (IoT), it is made possible to control various devices from a single device. Example: home automation using a mobile phone.
- iv) It enables smart classrooms, online availability of notes, monitoring student activities etc. in the field of education.



Recently, the mobile communication technology has evolved through various stages like 2G, 3G, 4G, 5G, WiMAX, Wibro, EDGE, GPRS and many others. This helps to increase the speed of communication and the range of coverage. The connectivity issues have decreased with reliable and secure connections. The GPS (Global Positioning System) and GSM (Global System for Mobile communication) technology play an important role in mobile communication. This increases the utilization of bandwidth of the network, sharing of the networks, error detections, etc. Many methods like digital switching, TDMA, CDMA have been used to ease the communication process.

10.10

INTERNET

Internet is a fast growing technology in the field of communication system with multifaceted tools. It provides new ways and means to interact and connect with people.

Internet is the largest computer network recognized globally that connects millions of people through computers. It finds extensive applications in all walks of life.



To store all the information available on the internet, you would need over 1 billion DVDs or 200 million Blu-ray discs.

Applications:

- i) **Search engine:** The search engine is basically a web-based service tool used to search for information on World Wide Web.
- ii) **Communication:** It helps millions of people to connect with the use of social networking: emails, instant messaging services and social networking tools.
- iii) **E-Commerce:** Buying and selling of goods and services, transfer of funds are done over an electronic network.

10.11

GLOBAL POSITIONING SYSTEM

GPS stands for Global Positioning System. It is a *global* navigation satellite system that offers geolocation and time information to a GPS receiver anywhere on or near the Earth.

GPS system works with the assistance of a satellite network. Each of these satellites broadcasts a precise signal like an ordinary radio signal. These signals that convey the location data are received by a low-cost aerial which is then translated by the GPS software. The software is able to recognize the satellite, its location, and the time taken by the signals to travel from each satellite.



Figure 10.10 Constellation of GPS satellites around Earth

The software then processes the data it accepts from each satellite to estimate the location of the receiver.

Applications

Global positioning system is highly useful many fields such as fleet vehicle management (for tracking cars, trucks and buses), wildlife management (for counting of wild animals) and engineering (for making tunnels, bridges etc).

10.12

APPLICATION OF INFORMATION AND COMMUNICATION TECHNOLOGY IN AGRICULTURE, FISHERIES AND MINING

(i) Agriculture

The implementation of information and communication technology (ICT) in agriculture sector enhances the

productivity, improves the living standards of farmers and overcomes the challenges and risk factors.

- a) ICT is widely used in increasing food productivity and farm management.
- b) It helps to optimize the use of water, seeds and fertilizers etc.
- c) Sophisticated technologies that include robots, temperature and moisture sensors, aerial images, and GPS technology can be used.
- d) Geographic information systems are extensively used in farming to decide the suitable place for the species to be planted.

(ii) Fisheries

- a) Satellite vessel monitoring system helps to identify fishing zones.
- b) Use of barcodes helps to identify time and date of catch, species name, quality of fish.

(iii) Mining

- a) ICT in mining improves operational efficiency, remote monitoring and disaster locating system.
- b) Information and communication technology provides audio-visual warning to the trapped underground miners.
- c) It helps to connect remote sites.

SUMMARY

- The basic elements required for the transmission and reception of a signal through long distance using electromagnetic waves are transducer, amplifier, carrier signal, modulator, power amplifier, medium of transmission, transmitting and receiving antenna, demodulator, detector.
- For long-distance transmission, the baseband signal is modulated with the carrier wave.
- If the amplitude of the carrier signal is modified with the instantaneous amplitude of the baseband signal then it is called amplitude modulation.
- The frequency of the carrier signal is modified with the instantaneous amplitude of the baseband signal in frequency modulation.
- The instantaneous amplitude of the baseband signal modifies the phase of the carrier signal keeping the amplitude and frequency constant is called phase modulation
- The height of the transmitting and receiving antenna must be a multiple of $\frac{\lambda}{4}$.
- If the EM waves transmitted by the transmitter glide over the surface of the earth to reach the receiver, then the propagation of EM waves is called ground wave propagation.
- Electromagnetic waves radiated from an antenna, directed upwards at large angles gets reflected by the ionosphere back to earth is called sky wave propagation.
- The process of sending and receiving information signal through space is called space wave communication.
- The satellite communication is a mode of communication of signal between transmitter and receiver via satellite.
- Fiber-optic communication is a method of transmitting information by sending pulses of light through an optical fiber.

- Radar basically stands for Radio Detection and Ranging System. It is one of the important applications of communication systems for remote sensing.
- Mobile Communication is used to communicate with others in different locations without the use of any physical connection like wires or cables.
- GPS stands for Global Positioning System that offers geolocation and time.
- Communication technology is used extensively in sectors like fisheries, mining, and agriculture.

CONCEPT MAP

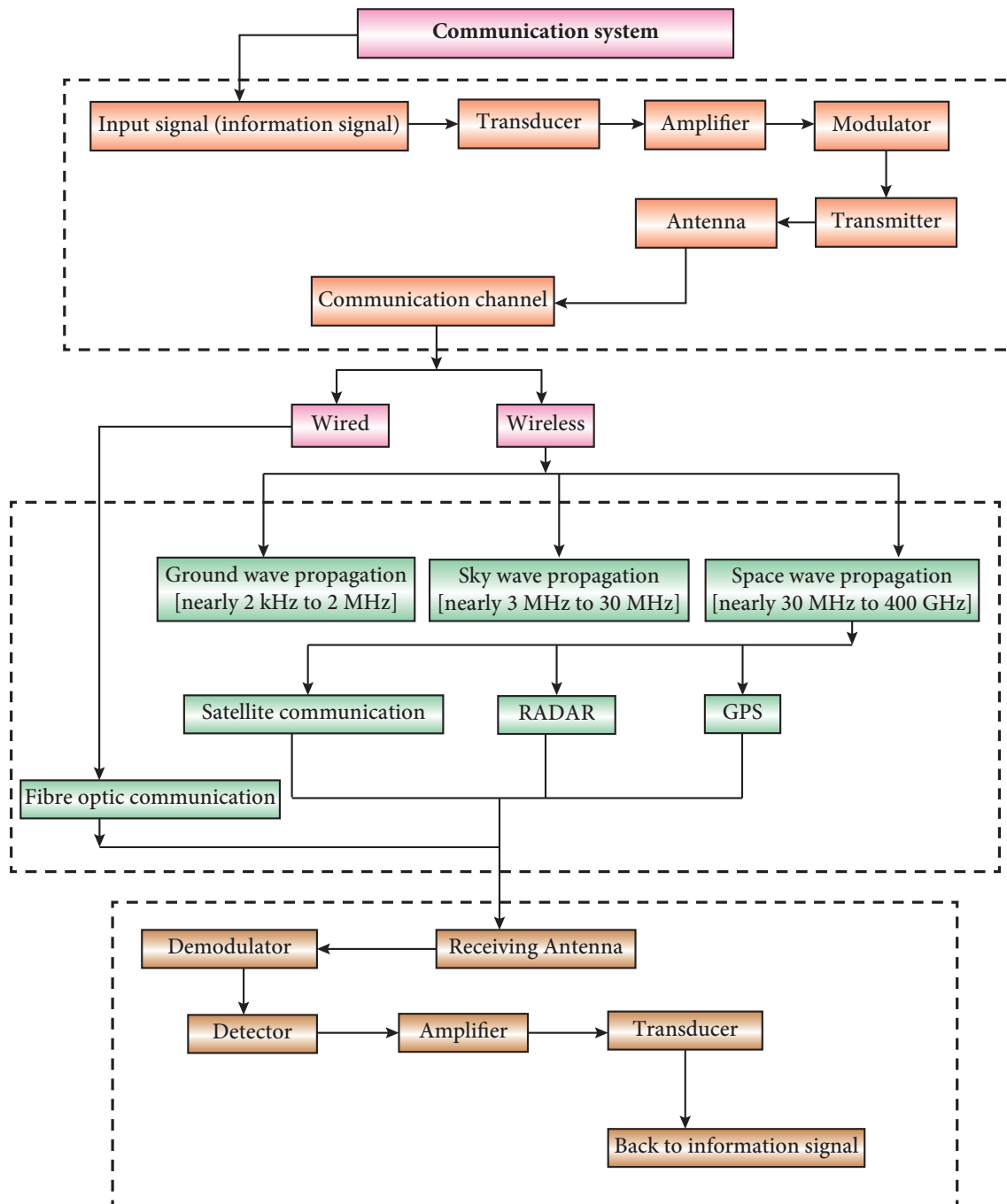

EVALUATION



I Multiple Choice Questions

- The output transducer of the communication system converts the radio signal into -----
 - Sound
 - Mechanical energy
 - Kinetic energy
 - None of the above
- The signal is affected by noise in a communication system
 - At the transmitter
 - At the modulator
 - In the channel
 - At the receiver
- The variation of frequency of carrier wave with respect to the amplitude of the modulating signal is called -----
 - Amplitude modulation
 - Frequency modulation
 - Phase modulation
 - Pulse width modulation
- The internationally accepted frequency deviation for the purpose of FM broadcasts.
 - 75 kHz
 - 68 kHz
 - 80 kHz
 - 70 kHz
- The frequency range of 3 MHz to 30 MHz is used for
 - Ground wave propagation
 - Space wave propagation
 - Sky wave propagation
 - Satellite communication



Answers

1. a 2. c 3. b 4. a 5. c

II Short answers

- Give the factors that are responsible for transmission impairments.
- Distinguish between wireline and wireless communication? Specify the range of electromagnetic waves in which it is used.
- Explain centre frequency or resting frequency in frequency modulation.
- What does RADAR stand for?
- What do you mean by Internet of Things?

III Long Answers

- What is modulation? Explain the types of modulation with necessary diagrams.
- Elaborate on the basic elements of communication system with the necessary block diagram.
- Explain the three modes of propagation of electromagnetic waves through space.
- What do you know about GPS? Write a few applications of GPS.
- Give the applications of ICT in mining and agriculture sectors.
- Modulation helps to reduce the antenna size in wireless communication – Explain.
- Fiber optic communication is gaining popularity among the various transmission media -justify.

BOOK FOR REFERENCES

1. B.L.Theraja, R.S. Sedha, *Principles of Electronics Devices and Circuits (Analog and Digital)*, S. Chand & Company, 2011.
2. K.D.Prasad, *Antenna and Wave Propagation*, Satya Prakashan, 2007.
3. U A Bakshi; A V Bakshi; K A Bakshi, *Antenna and Wave Propagation*, Technical Publications, 2014.



ICT CORNER

Communication systems

In this activity you will be able to visualize how the amplitude of the carrier wave is changed in accordance with the intensity of the signal.

Topic: Amplitude Modulation

STEPS:

- Go to 'academo.org' page. Click Physics → Waves → Amplitude Modulation or open the browser and type "academo.org/demos/amplitude-modulation/" in the address bar.
- Adjust the carrier wave (say $f_1 = 100$ Hz, 200 Hz, etc.) and observe how the modulated wave changes.
- Adjust the signal wave (Say $f_2 = 10$ Hz, 20 Hz, etc.) and observe how the modulated wave changes.
- Adjust the amplitude of the signal wave and observe how the modulated wave changes in accordance with intensity of the signal.

Step1

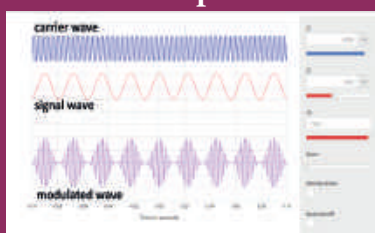

Step2

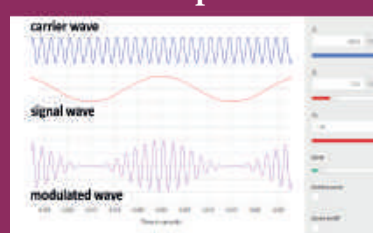

Note:

Login with the help of your mail id if you want to save your project in online.

URL:

<https://academo.org/demos/amplitude-modulation/>

* Pictures are indicative only.

* If browser requires, allow **Flash Player** or **Java Script** to load the page.



B263_12_PHYSICS_EM

UNIT 11

RECENT DEVELOPMENTS IN PHYSICS

'There's Plenty of Room at the Bottom: An Invitation to Enter a New Field of Physics'

-Richard Feynman

Learning Objectives

In this unit the students are exposed to

- Importance of physics for the development in all spheres
- Physics as the basic building block for engineering and technology
- Nanoscience and nanotechnology
- Physics in robotics
- Principles of physics in medical diagnosis and therapy
- Realise that the foundation to explore recent developments is covered in higher secondary physics
- Students are equipped to face challenges in higher education comfortably and confidently



11.1 Introduction

Physics is the basic building block for science, engineering and technology as depicted in Figure 11.1 (Refer XI Physics, 1.3). The fast developing fields like Nanoscience and Nanotechnology, Robotics and Medical diagnosis and therapy are briefly brought out for the students to appreciate the application of physics in these areas. This unit exposes the salient physics principles covered in the higher secondary physics as the foundation for technology break through. In addition, with the adequate exposure to basic physics at the school level, students are motivated to pursue higher education confidently in all fields related to science, engineering, technology and medicine.

Figure 11.1 Physics is the building block for science, engineering, technology and medicine
(Not for examination)



11.2 Nanoscience and Nanotechnology

11.2.1

Nanoscience

Nanoscience is the study of structures and materials on the scale of nanometers. Nano means one-billionth of a meter that is 10^{-9} m.

If matter is divided into such small objects the mechanical, electrical, optical, magnetic and other properties change.

Nanotechnology

Nanotechnology is a technology involving the design, production, characterization, and applications of nano structured materials.

Nanoparticles

The solids are made up of particles. Each of the particle has a definite number of atoms, which might differ from material to material. If the particle of a solid is of size less than 100 nm, it is said to be a 'nano solid'. When the particle size exceeds 100 nm, it is a 'bulk solid'. It is to be noted that nano and bulk solids may be of the same chemical composition. For example, ZnO can be both in bulk and nano form. Though chemical composition is the same, nano form of the material shows strikingly different properties when compared to its bulk counterpart.

In the nano scale dimensions (reduced dimensions), two important phenomena govern nano properties. They are quantum confinement effects and surface effects. Students can explore these effects in higher education and the explanation is avoided at school level.

11.2.2 Interdisciplinary nature of Nanotechnology

Nanoscience and technology is the interdisciplinary area covering its applications in various fields

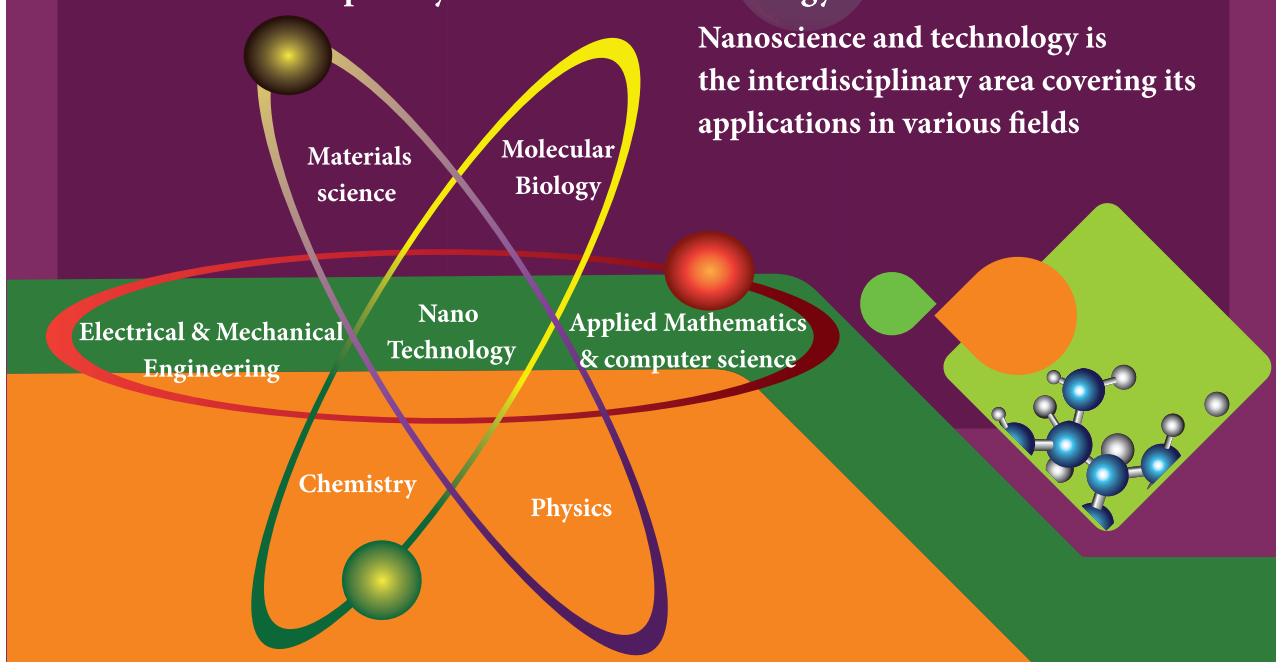



11.2.3 Nano in Nature

Nanoscale structures existed in nature long before scientists began studying them in laboratories.

A few examples

Object

A single strand of DNA, the building block of all living things, is about three nanometers wide.

single strand DNA



double strand DNA

Nano in Nature

Mimic in laboratories

Manipulation of colours by adjusting the size of nano particles with which the materials are made.



Nano in Nature

Object

The scales on the wings of a morpho butterfly contain nanostructures that change the way light waves interact with each other, giving the wings brilliant metallic blue and green hues.

Object

Peacock feathers get their iridescent coloration from light interacting with 2 dimensional photonic crystal structures just tens of nanometers thick.

Nano in Nature

Mimic in laboratories

Similar nano structures are made in lab to glow in different colors.



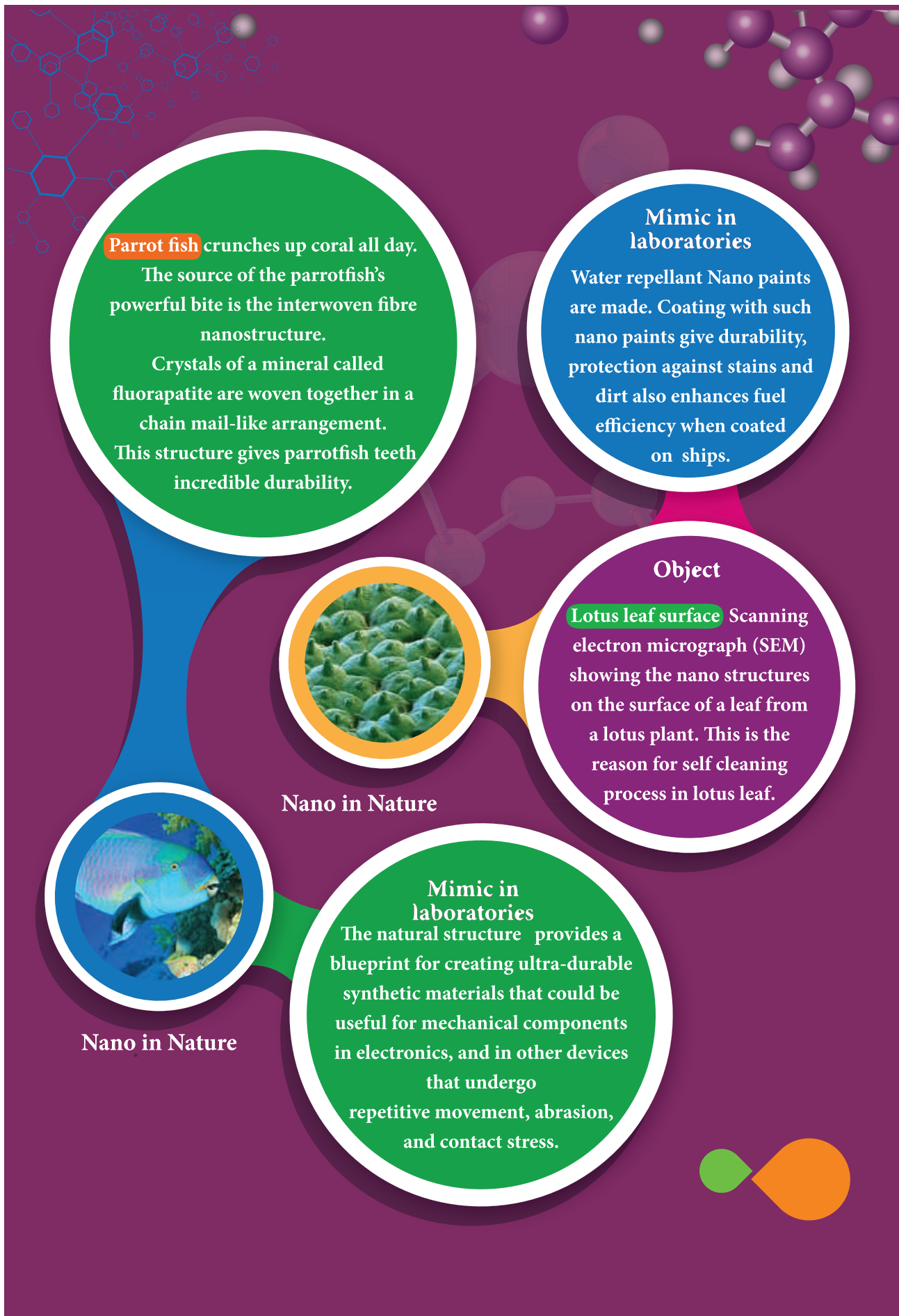

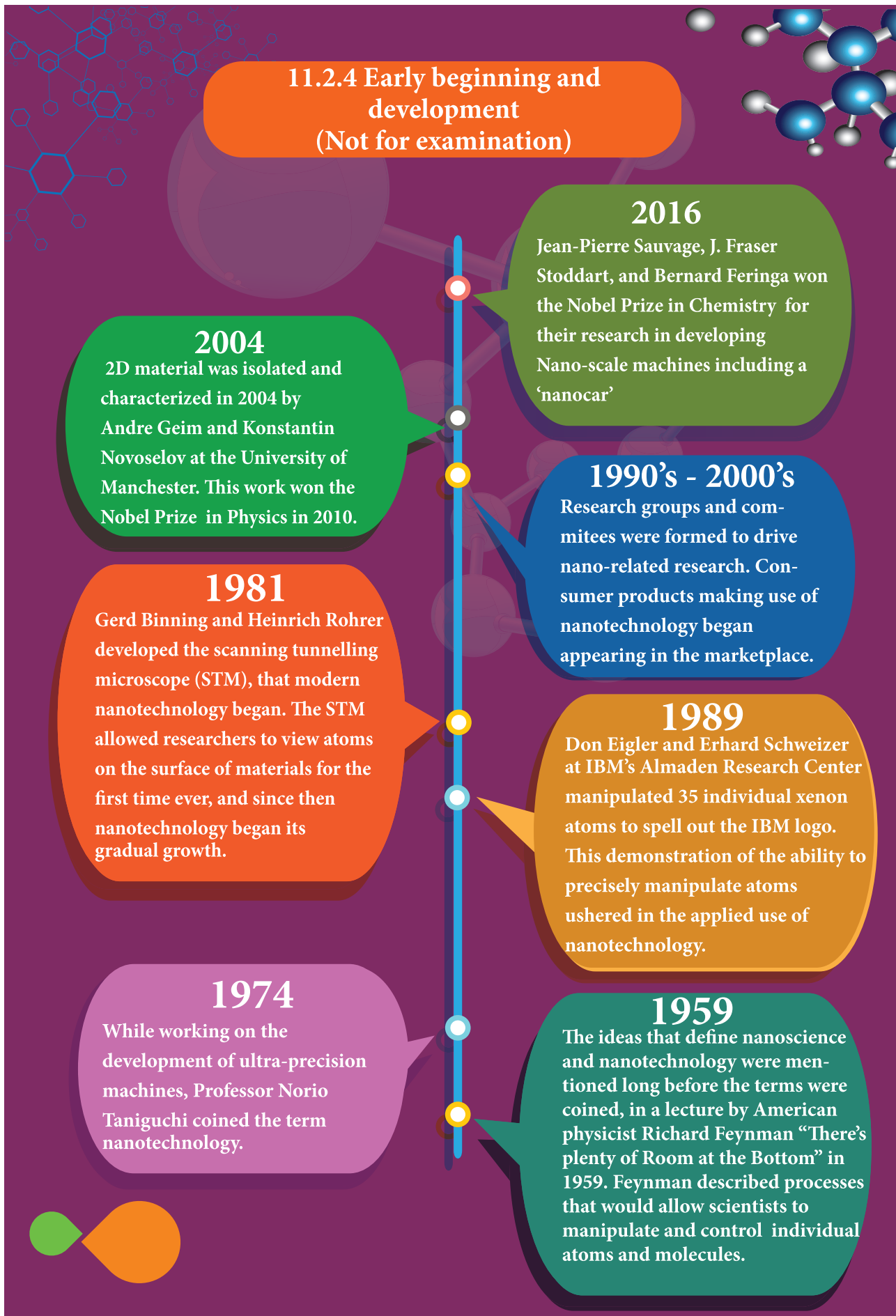



11. 2.5 Nano in laboratories

The nanostructures made in the laboratory mimic some of nature's amazing nanostructures. As the nanostructures are so small, specialized methods are needed to manufacture objects in this size range. There are two ways of preparing the nanomaterials, top down and bottom up approaches.

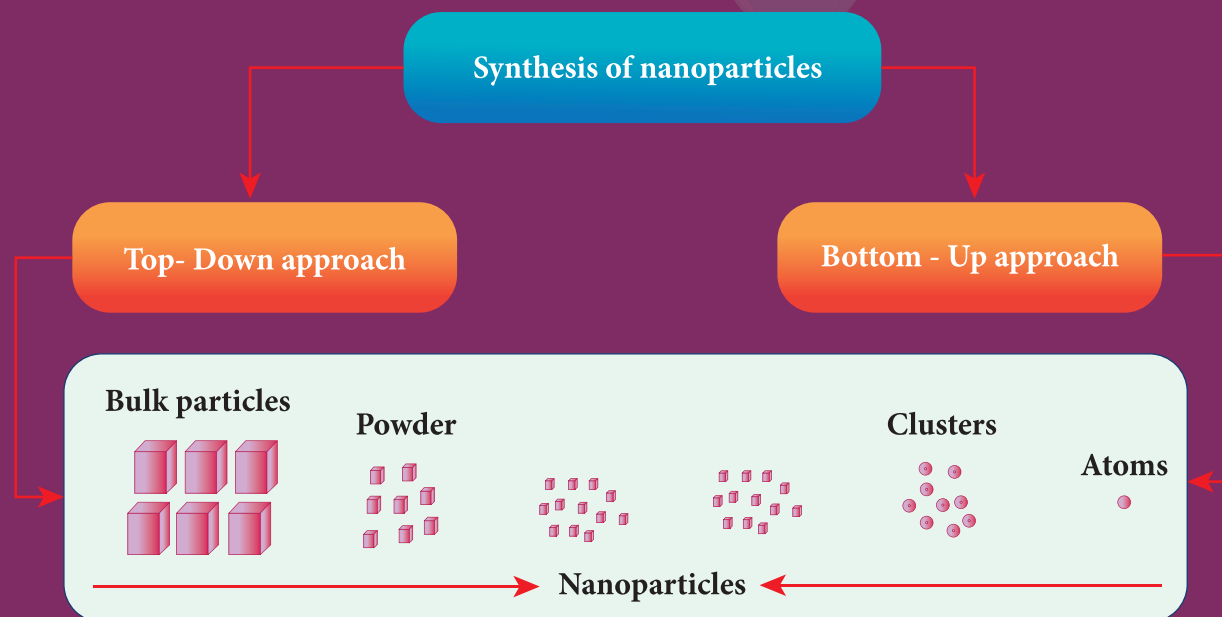
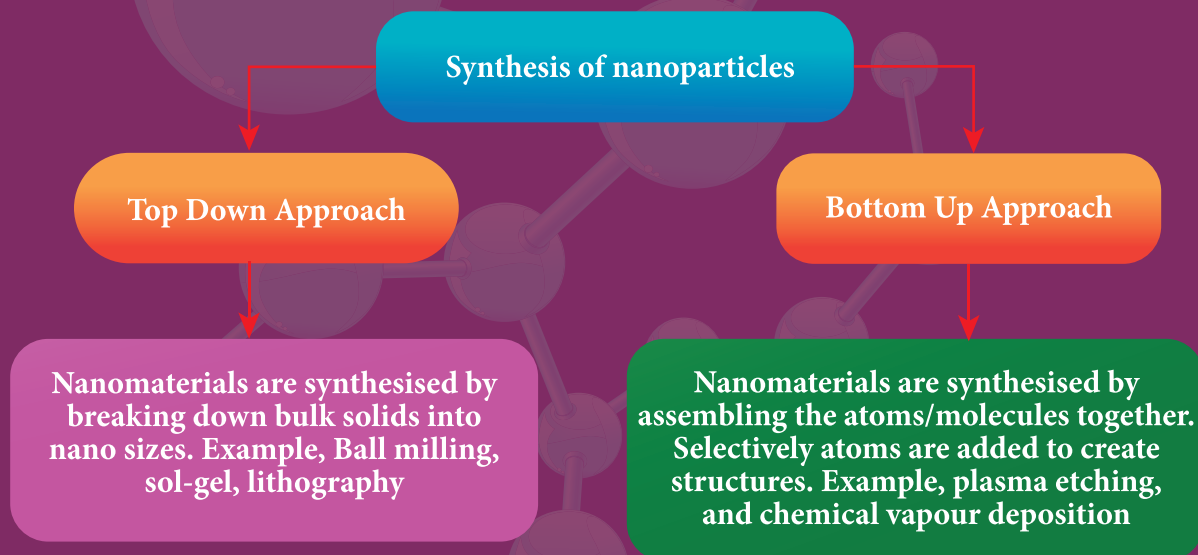

Due to the vast available methods the details are avoided at this level.

11.2.6 Applications of Nano technology

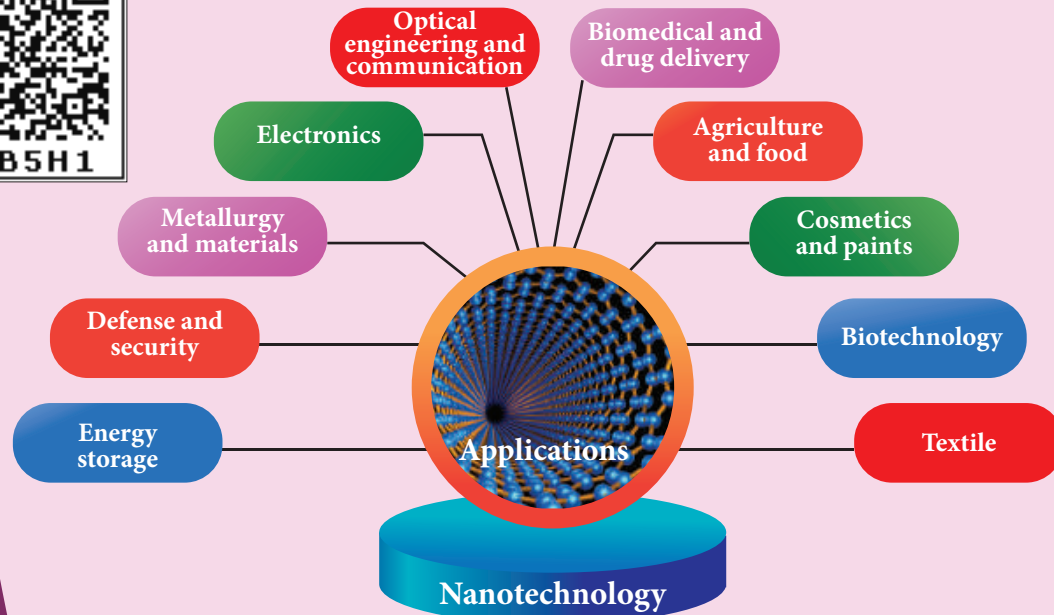

Applications of nanomaterial based products in differernt areas

<p>Automotive industry</p> <ul style="list-style-type: none"> • Lightweight construction • Painting (fillers, base coat, clear coat) • Catalysts • Tires (fillers) • Sensors • Coatings for wind-screen and car bodies 	<p>Chemical industry</p> <ul style="list-style-type: none"> • Fillers for paint systems • Coating systems based on nanocomposites • Impregnation of papers • Switchable adhesives • Magnetic fluids 	<p>Engineering</p> <ul style="list-style-type: none"> • Wear protection for tools and machines (anti blocking coatings, scratch resistant coatings on plastic parts, etc.) • Lubricant-free bearings
<p>Electronic industry</p> <ul style="list-style-type: none"> • Data memory • Displays • Laser diodes • Glass fibres • Optical switches • Filters (IR-blocking) • Conductive, antistatic coatings 	<p>Construction</p> <ul style="list-style-type: none"> • Construction materials • Thermal insulation • Flame retardants • Surface-functionalised building materials for wood, floors, stone, facades, tiles, roof tiles, etc. • Facade coatings • Groove mortar 	<p>Medicine</p> <ul style="list-style-type: none"> • Drug delivery systems • Active agents • Contrast medium • Medical rapid tests • Prostheses and implants • Antimicrobial agents and coatings • Agents in cancer therapy



<p style="text-align: center;">Textile/fabrics/ non-wovens</p> <ul style="list-style-type: none"> • Surface-processed textiles • Smart clothes 	<p style="text-align: center;">Energy</p> <ul style="list-style-type: none"> • Fuel cells • Solar cells • Batteries • Capacitors 	<p style="text-align: center;">Cosmetics</p> <ul style="list-style-type: none"> • Sun protection • Lipsticks • Skin creams • Tooth paste
<p style="text-align: center;">Food and drinks</p> <ul style="list-style-type: none"> • Package materials • Storage life sensors • Additives • Clarification of fruit juices 	<p style="text-align: center;">Household</p> <ul style="list-style-type: none"> • Ceramic coatings for irons • Odors catalyst • Cleaner for glass, ceramic, floor, windows 	<p style="text-align: center;">Sports/ outdoor</p> <ul style="list-style-type: none"> • Ski wax • Antifogging of glasses/goggles • Antifouling coatings for ships/boats • Reinforced tennis rackets and balls

11.2.7 Possible harmful effects of nanoparticles

The research on the harmful impact of application of nanotechnology is also equally important and fast developing. The major concern here is that the nanoparticles have the dimensions same as that of the biological molecules such as proteins. They may easily get absorbed onto the surface of living organisms and they might enter the tissues and fluids of the body.

The adsorbing nature depends on the surface of the nanoparticle. Indeed, it is possible to deliver a drug directly to a specific cell in the body by designing the surface of a nanoparticle so that it adsorbs specifically onto the surface of the target cell.

The interaction with living systems is also affected by the dimensions of the nanoparticles. For instance, nanoparticles of a few nanometers size may reach well inside biomolecules, which is not possible for larger nanoparticles. Nanoparticles can also cross cell membranes. It is also possible for the inhaled nanoparticles to reach the blood, to reach other sites such as the liver, heart or blood cells.

Researchers are trying to understand the response of living organisms to the presence of nanoparticles of varying size, shape, chemical composition and surface characteristics.

DISEASES ASSOCIATED TO NANOPARTICLE EXPOSURE (Not for examination)

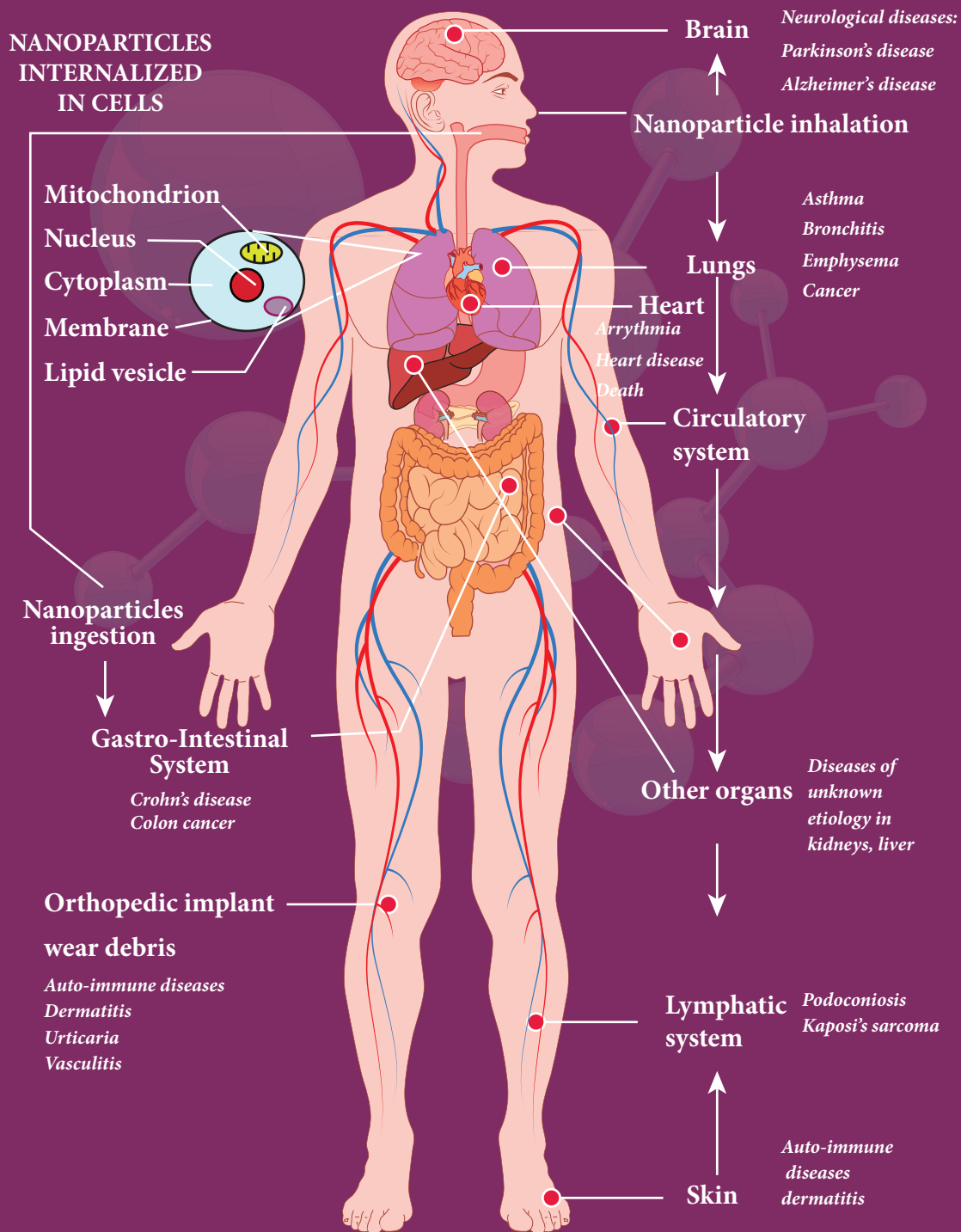



11.3 Robotics

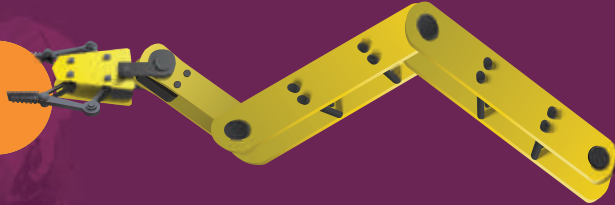

11.3.1 What is robotics?

Robotics is an integrated study of mechanical engineering, electronic engineering, computer engineering, and science. Robot is a mechanical device designed with electronic circuitry and programmed to perform a specific task. These automated machines are highly significant in this robotic era. They can take up the role of humans in certain dangerous environments that are hazardous to people like defusing bombs, finding survivors in unstable ruins, and exploring mines and shipwrecks.

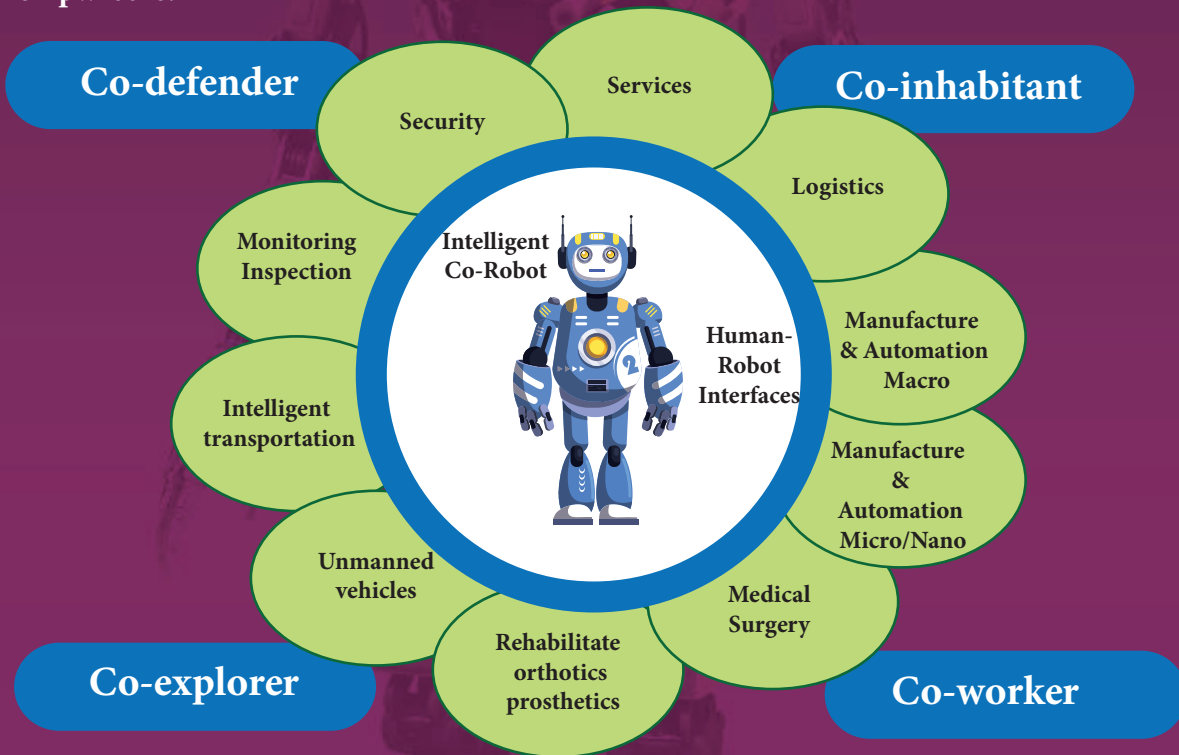

In 1954, George Devol invented the first digitally operated programmable robot called Unimate. George Devol and Joseph Engelberger, the father of the modern robotics industry formed the world's first robot company in 1956. In 1961, Unimate, was operated in a General Motors automobile factory for moving car parts around in New Jersey.

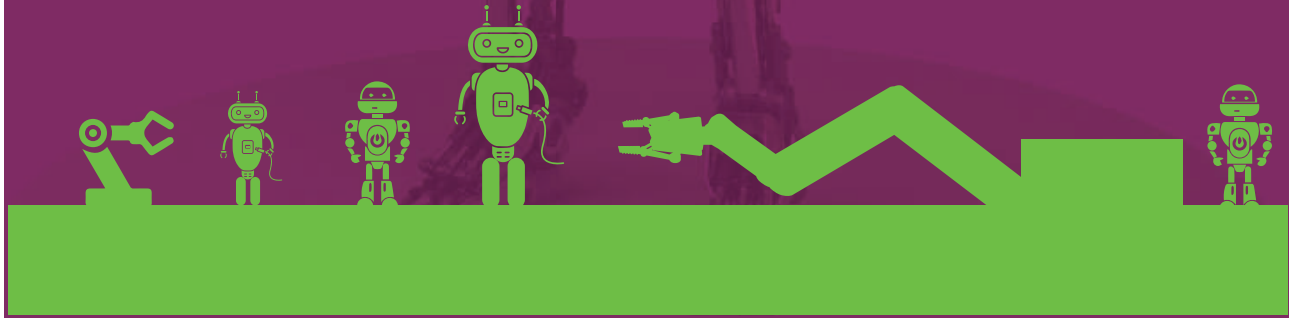

11.3.2 COMPONENTS OF ROBOTICS

The robotic system mainly consists of sensors, power supplies, control systems, manipulators and necessary software.

Most robots are composed of 3 main parts:

1. **The Controller** - also known as the "brain" which is run by a computer program. It gives commands for the moving parts to perform the job.
2. **Mechanical parts** - motors, pistons, grippers, wheels, and gears that make the robot move, grab, turn, and lift.
3. **Sensors** - to tell the robot about its surroundings. It helps to determine the sizes and shapes of the objects around, distance between the objects, and directions as well.

Key components

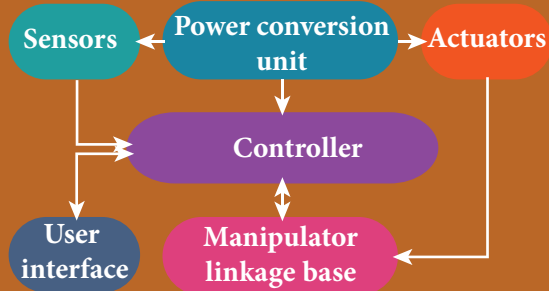

11.3.3 TYPES OF ROBOTS

HUMAN ROBOT

Certain robots are made to resemble humans in appearance and replicate the human activities like walking, lifting, and sensing, etc.

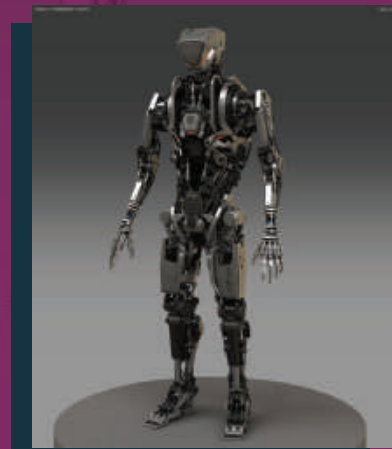

1. **Power conversion unit:** Robots are powered by batteries, solar power, and hydraulics.
2. **Actuators:** Converts energy into movement. The majority of the actuators produce rotational or linear motion.
3. **Electric motors:** They are used to actuate the parts of the robots like wheels, arms, fingers, legs, sensors, camera, weapon systems etc. Different types of electric motors are used. The most often used ones are AC motor, Brushed DC motor, Brushless DC motor, Geared DC motor, etc.
4. **Pneumatic Air Muscles:** They are devices that can contract and expand when air is pumped inside. It can replicate the function of a human muscle. They contract almost 40% when the air is sucked inside them.
5. **Muscle wires:** They are thin strands of wire made of shape memory alloys. They can contract by 5% when electric current is passed through them.
6. **Piezo Motors and Ultrasonic Motors:** Basically, we use it for industrial robots.
7. **Sensors:** Generally used in task environments as it provides information of real-time knowledge.
8. **Robot locomotion:** Provides the types of movements to a robot. The different types are
 - (a) Legged
 - (b) Wheeled
 - (c) Combination of Legged and Wheeled Locomotion
 - (d) Tracked slip/skid

INDUSTRIAL ROBOTS

Six main types of industrial robots

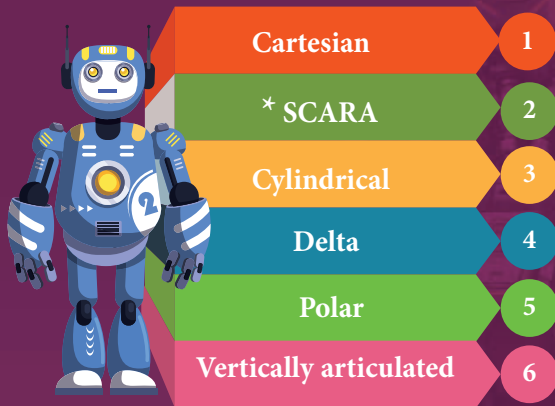

*Selective Compliance Assembly Robot Arm

Six-axis robots are ideal for

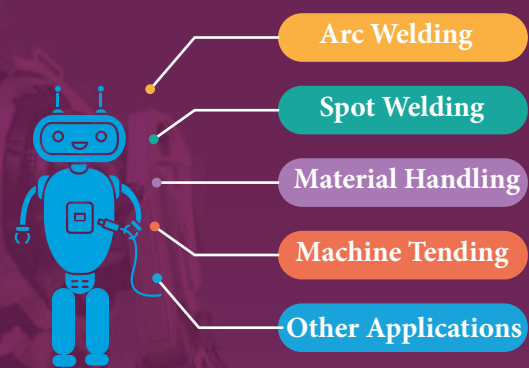

Artificial Intelligence



Artificial Intelligence

The aim of artificial intelligence is to bring in human like behaviour in robots. It works on

1. Face recognition
2. Providing response to player's actions in computer games
3. Taking decisions based on previous actions
4. To regulate the traffic by analyzing the density of traffic on roads.
5. Translate words from one language to another



11.3.4 Applications

Outer space: Exploring stars, planets etc., investigation of the mineralogy of the rocks and soils on Mars, analysis of elements found in rocks and soils.

Mars Rovers of NASA



Twin Mars Rovers



Mars Pathfinder Mission



Litter robot



Welding



Cutting



Assembling



Vacuum Cleaners



Packing



Transport



Surgery



Weaponry



Lawn mowing



Laboratory



Underwater



Hospitals

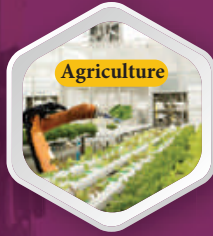

Agriculture



Pool cleaning



Nanorobots

The size of the nano robots is reduced to microscopic level to perform a task in very small spaces. However, it is only in the developmental stage. The future prospects of it are much expected in the medical field: Nano-robots in blood stream to perform small surgical procedures, to fight against bacteria, repairing individual cell in the body. It can travel into the body and once after the job is performed it can find its way out. Chinese scientists have created the world's first autonomous DNA robots to combat cancer tumours.



Materials used to make robots

For robots, aluminum and steel are the most common metals. Aluminum is a softer metal and is therefore easier to work with, but steel is several times stronger. In any case, because of the inherent strength of metal, robot bodies are made using sheet, bar, rod, channel, and other shapes.

11.3.5 Advantages of Robotics

1. The robots are much cheaper than humans.
2. Robots never get tired like humans. It can work for 24 x 7. Hence absenteeism in work place can be reduced.
3. Robots are more precise and error free in performing the task.
4. Stronger and faster than humans.
5. Robots can work in extreme environmental conditions: extreme hot or cold, space or underwater. In dangerous situations like bomb detection and bomb deactivation.
6. In warfare, robots can save human lives.
7. Robots are significantly used in handling materials in chemical industries especially in nuclear plants which can lead to health hazards in humans.

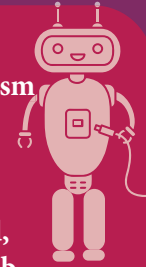

11.3.6 Disadvantages of Robotics



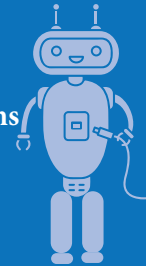



1. Robots have no sense of emotions or conscience.
2. They lack empathy and hence create an emotionless workplace.
3. If ultimately robots would do all the work, and the humans will just sit and monitor them, health hazards will increase rapidly.
4. Unemployment problem will increase.
5. Robots can perform defined tasks and cannot handle unexpected situations
6. The robots are well programmed to do a job and if a small thing goes wrong it ends up in a big loss to the company.
7. If a robot malfunctions, it takes time to identify the problem, rectify it, and even reprogram if necessary. This process requires significant time.
8. Humans cannot be replaced by robots in decision making.
9. Till the robot reaches the level of human intelligence, the humans in work place will exit.



11. 4 Physics in medical diagnosis and therapy

Medical science very much revolves around physics principles. Medical instrumentation has widened the life span due to the technology integrated diagnosis and treatment of most of the diseases. This modernisation in all fields is possible due to efficient application of fundamental physics.

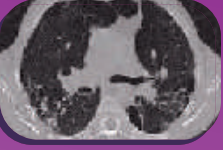
11.4.1 The development in medical field has been proportional to the evolution of physics as indicated below (Not for examination)

Year	Invention in physics (Inventors)	Technique used in medicine	Image
1 1895	X-rays (Wilhelm Conrad-Röntgen)	Radiology-Xray imaging	
2 1896 and 1898	Theory of Radioactivity (Antonie Henri Becquerel, Pierre Curie and Marie Cuire)	Radioisotope imaging Nuclear Medicine	
3 1934	Artifical Radioactivity (Joliot and Irene Curie)	Scintigraphy	
4 1950	Echography & Sonography	Ecography	
5 1979	X-ray computed tomography (Cormack and Hounsfield)	Computed Tomography (CT)	
6 1952	Nuclear Magnetic Resonance (NMR) (Felix Bloch and Edward Purcell)	Magnetic Resonance Imaging (MRI)	



Year	Invention in physics (Inventors)	Technique used in medicine	Image
7 1934	Artificial Radioactivity (Joliot and Irene Curie)	Positron Emission Tomography	
8 1940's	Optical fibre	Endoscopy, Biomedical sensors	
9 1960	LASER	Surgical instrument and diagnosis tool	
10 1959	Nanotechnology	Nanomedicine Drug delivery	
11 2005	Dual Source Computed Tomography (DSCT)	Computed Tomography (CT)	
12 1998	Nuclear medicine (David Townsend, Ronald Nutt)	Fusion Imaging Techniques (PET-CT, PET-MR)	



11.4. 2 The recent advancement in medical technology includes

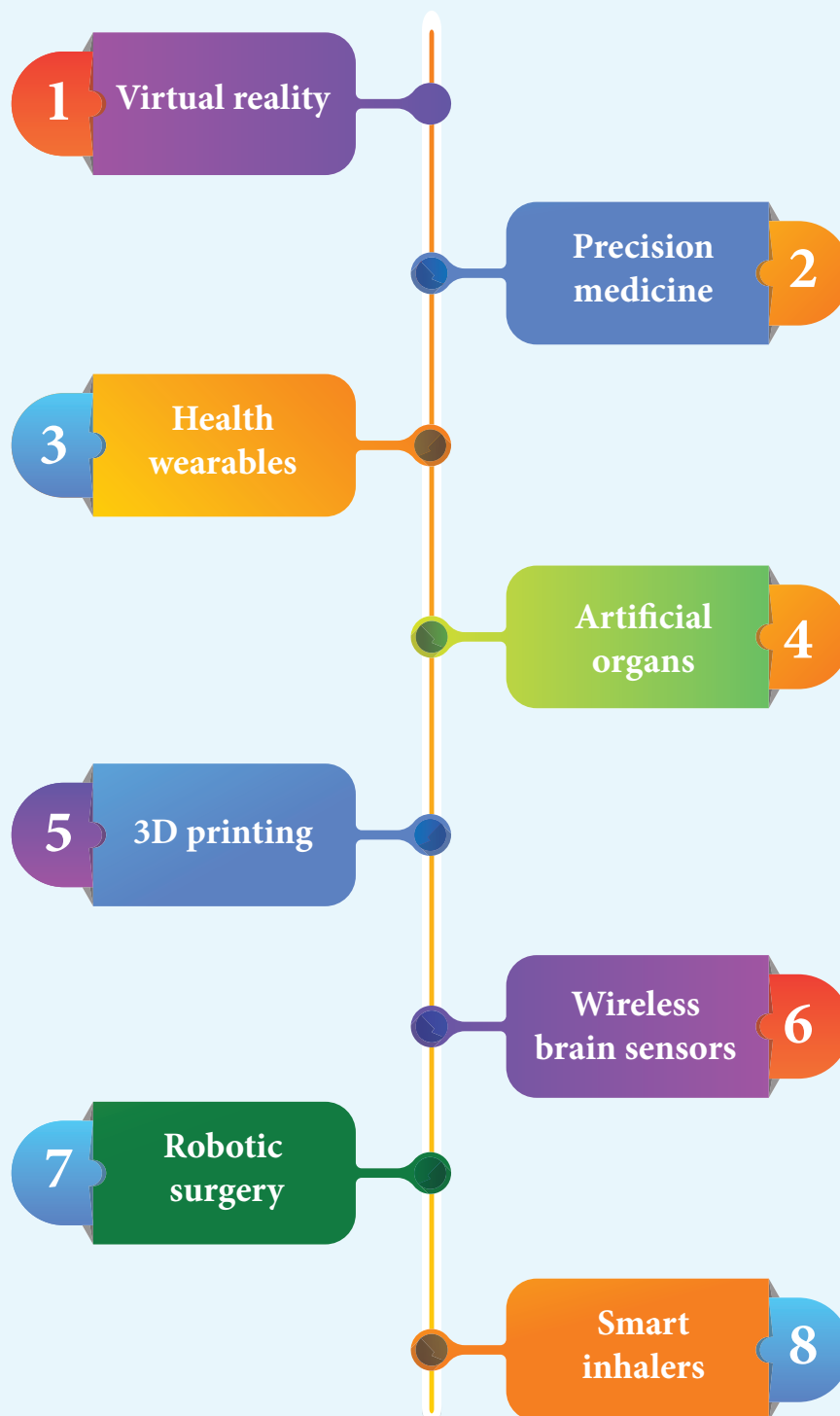

The innovation in medical diagnosis has taken leaps and bounds due to the integration of technology and basic physics. A few of such advancements are discussed.

1. Virtual reality

1

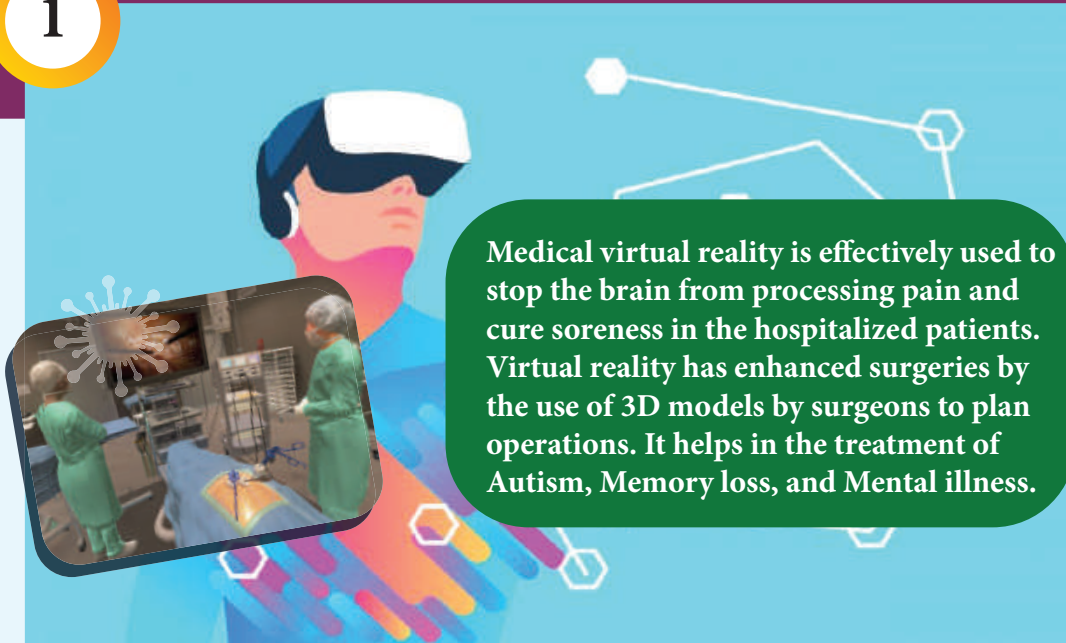

2

2. Precision medicine

Precision medicine is an emerging approach for disease treatment and prevention that takes into account individual variability in genes, environment, and lifestyle for each person. In this medical model it is possible to customise healthcare, with medical decisions, treatments, practices, or products which are tailored to the individual patient.

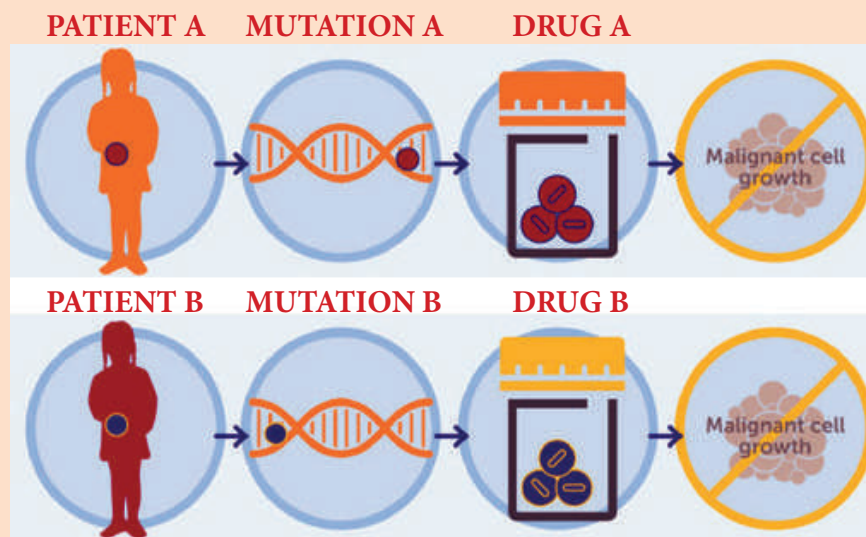

3

3. Health wearables

A health wearable is a device used for tracking a wearer's vital signs or health and fitness related data, location, etc. Medical wearables with artificial intelligence and big data provide an added value to healthcare with a focus on diagnosis, treatment, patient monitoring and prevention.

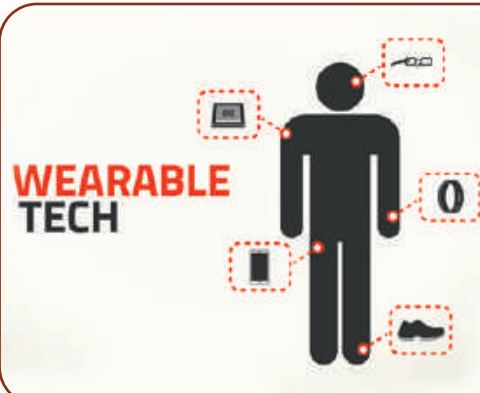

NOTE

Big Data: Extremely large data sets that may be analysed computationally to reveal patterns, trends, and associations, especially relating to human behaviour and interactions.

4

4. Artificial organs

An artificial organ is an engineered device or tissue that is implanted or integrated into a human. It is possible to interface it with living tissue or to replace a natural organ. It duplicates or augments a specific function or functions of human organs so that the patient may return to a normal life as soon as possible.



5

5. 3D printing

Advanced 3D printer systems and materials assist physicians in a range of operations in the medical field from audiology, dentistry, orthopedics and other applications.



6

6. Wireless brain sensors

Wireless brain sensors monitor intracranial pressure and temperature and then are absorbed by the body. Hence there is no need for surgery to remove these devices.

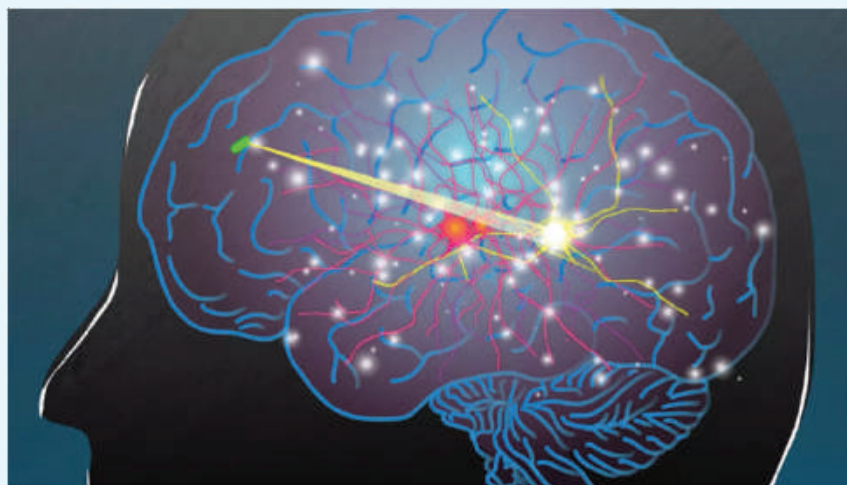

7

7. Robotic surgery

Robotic surgery is a type of surgical procedure that is done using robotic systems. Robotically-assisted surgery helps to overcome the limitations of pre-existing minimally-invasive surgical procedures and to enhance the capabilities of surgeons performing open surgery.



8

8. Smart inhalers

Inhalers are the main treatment option for asthma. Smart inhalers are designed with health systems and patients in mind so that they can offer maximum benefit. Smart inhalers use bluetooth technology to detect inhaler use, remind patients when to take their medication and gather data to help guide care.



Other recent developments in physics

Particle Physics

Particle physics deals with the theory of fundamental particles of nature and it is one of the active research areas in physics. Initially it was thought that atom is the fundamental entity of matter. In 1930s, it was established that atoms are made up of electrons, protons and neutrons.

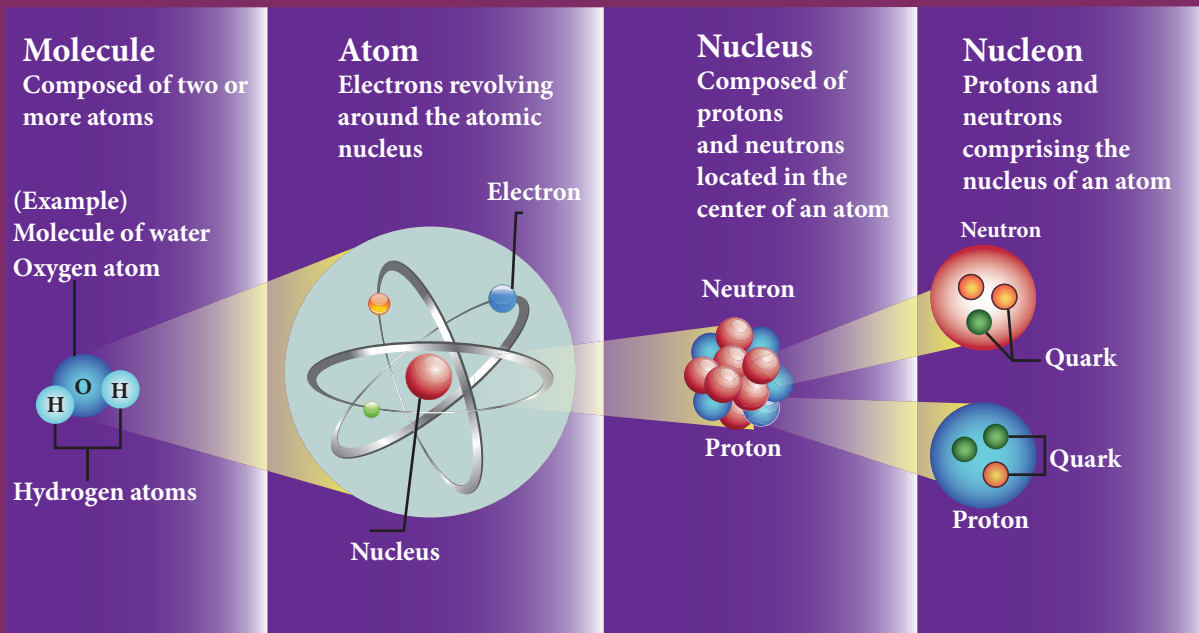

In the 1960s, quarks were discovered and it was understood that proton and neutron are made up of quarks. In the meantime, the particle physics research gained momentum and has grown exponentially both in theoretical and experimental perspective. Later it was found that the quarks interact through gluons. It is the field which received more number of noble prizes. Recently in the year 2013, famous 'Higgs particles' also known as "God" particles were discovered and for this, Peter Higgs and Englert received noble prize in physics. It is the 'Higgs particle' which gives mass to many particles like protons, neutrons etc.



Cosmology

Cosmology is the branch that involves the origin and evolution of the universe. It deals with formation of stars, galaxy etc. In the year 2015, the existence of “gravitational waves” was discovered and noble prize was awarded for this discovery in the year 2017.

Gravitational waves are the disturbances in the curvature of space-time and it travels with speed of light. Any accelerated charge emits electromagnetic wave. Similarly any accelerated mass emits gravitational waves but these waves are very weak even for masses like earth. The strongest source of gravitational waves are black holes. The discovery of gravitational waves made it possible to study the structure of black holes since it is the strongest source of gravitational waves. In fact, the recent discoveries of gravitational waves are emitted by two black holes when they merge to a single black hole. In fact, Albert Einstein theoretically proposed the existence of ‘gravitational waves’ in the year 1915. After 100 years, it is experimentally proved that his predictions are correct.

Gravitational wave



Black holes are end stage of stars which are highly dense massive object. Its mass ranges from 20 times mass of the sun to 1 million times mass of the sun. It has very strong gravitational force such that no particle or even light can escape from it. The existence of black holes is studied when the stars orbiting the black hole behave differently from the other stars. Every galaxy has black hole at its center. Sagittarius A* is the black hole at the center of the Milky Way galaxy.

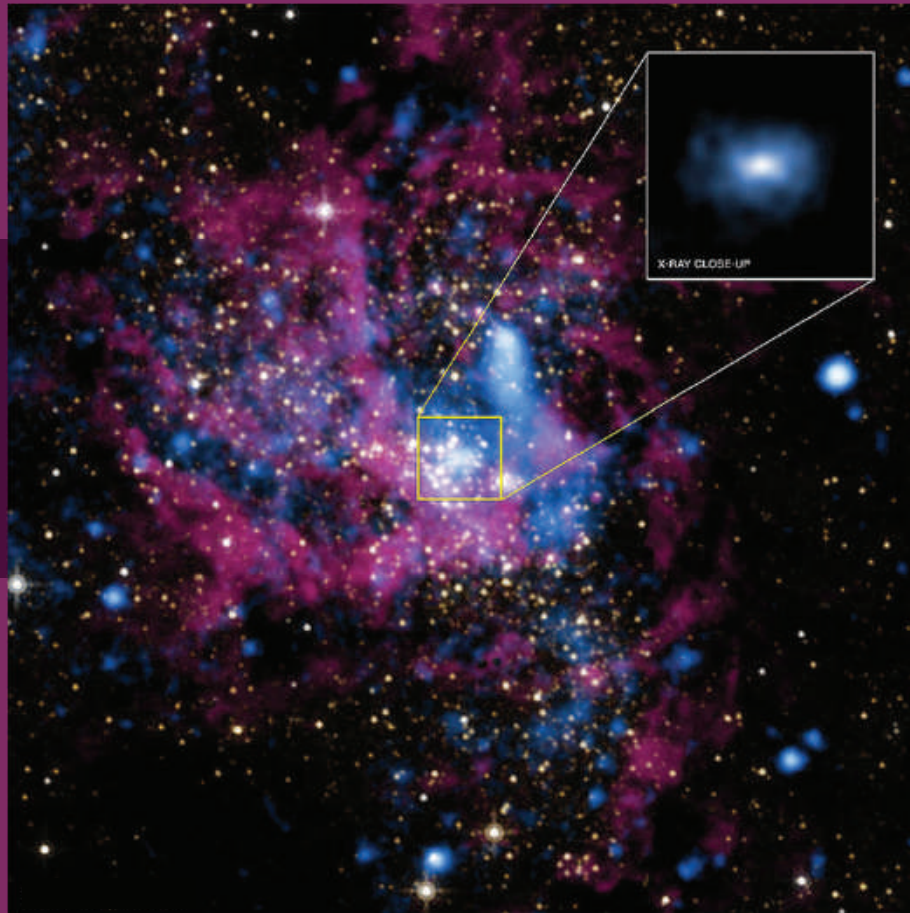

Black hole sagittarius A*

The famous physicist Stephen Hawking worked in the field of black holes.

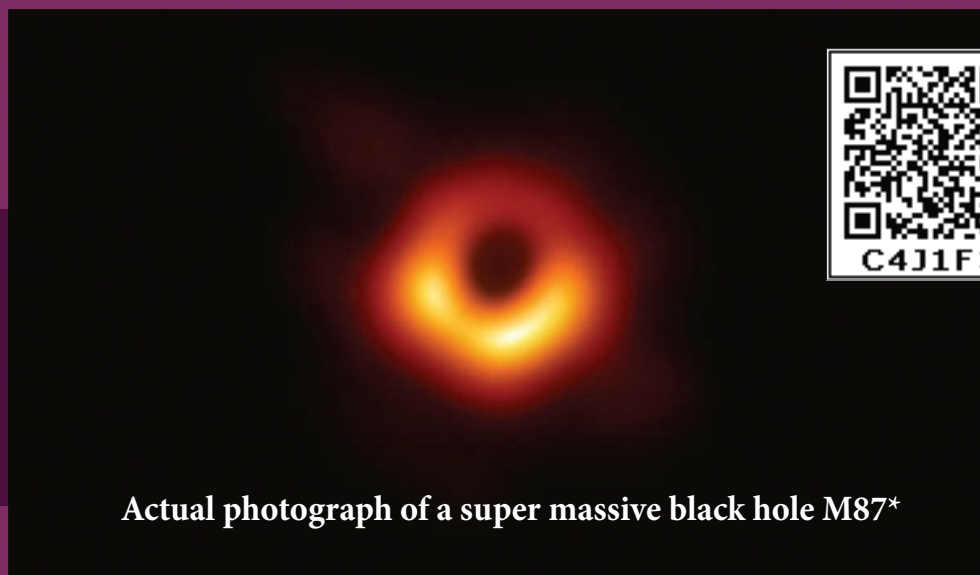

Actual photograph of a super massive black hole M87*

Super computers and eight telescopes stationed on five continents (EVENT HORIZON TELESCOPE) were used to develop a huge data to accomplish this. It has once again confirmed the Einstein's theory of general relativity.



Quantum information theory (Not for examination)

It is another fast developing research area which deals with improving the information storage using quantum computers. The present computers store information in the form of 'bits' but quantum computers store information in the form of 'qubits'. 'qubit' refers to quantum bit and it is the basic unit of quantum information. Classical bit implies either 0 or 1. But qubit not only includes 0 or 1 and also linear superposition of 0 and 1. This technology reduces the calculating time exponentially. This research field has very promising application in future.

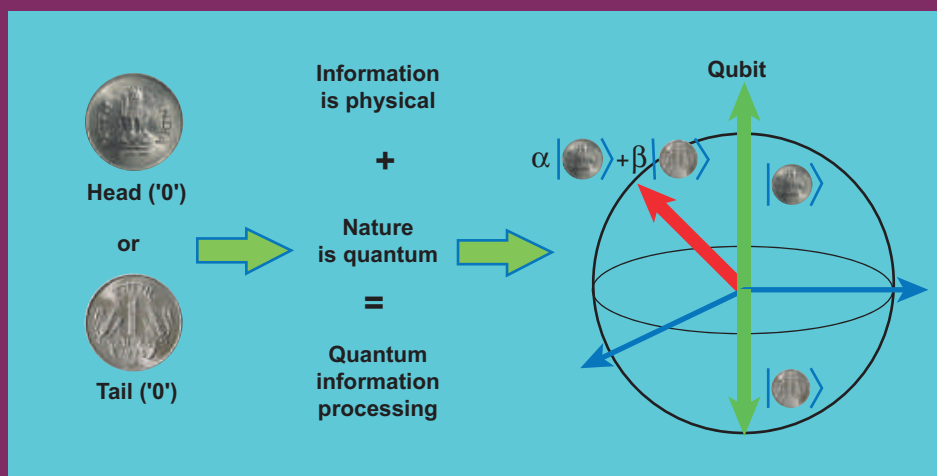

Many striking innovations and discoveries originate from scientific fictions. Robots are also no exception to this. The word robotics was derived from the word robot. It was introduced in the play 'Rossum Universal Robots' by the Czech writer Karel Capek in 1920. The word robot comes from the Slavic word rabota, which means labour or work. The play begins in a factory that makes artificial people called robots. They looked like creatures that can be mistaken for humans (picture shown). These characters were very similar to the modern ideas of androids.

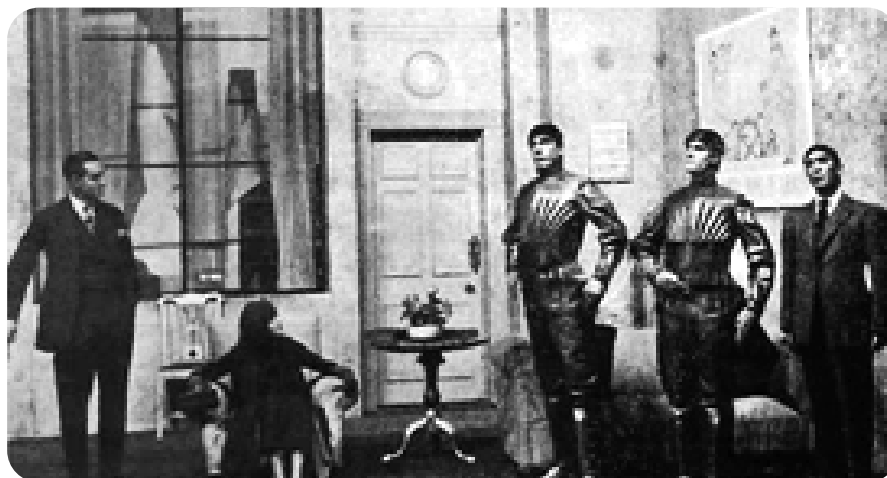

(A scene from the play Rossum Universal Robots, showing three robots)

SUMMARY

- Salient physics principles (covered in the higher secondary physics) are the foundation for technology break through.
- Physics is the basic building block for Science, Engineering, Technology and Medicine. Nano science is the science of objects with typical sizes of 1–100 nm.
- Nano means one-billionth of a metre that is 10^{-9} m.
- Nanotechnology is a technology involving the design, production, characterization, and applications of nano structural materials.
- If the particle of a solid is of size less than 100 nm, it is said to be a ‘nano solid’.
- When the particle size exceeds 100 nm, it forms a ‘bulk solid’.
- Nano form of the material shows strikingly different properties when compared to its bulk counterpart.
- Quantum confinement effects and surface effects are the two important phenomena that govern nano properties.
- Nanoscience and technology is the interdisciplinary area covering its applications in various fields.
- Nano scale structures existed in nature long before scientists began studying them in laboratories.
- There are two ways of preparing the nanomaterials, top down and bottom up approaches.
- Nanotechnology applications cover various fields.
- The major concern with nano application is that the nanoparticles have the dimensions same as that of the biological molecules such as proteins.
- Nano particles can easily get absorbed onto the surface of living organisms and they might enter the tissues and fluids of the body.
- The adsorbing nature depends on the surface of the nanoparticle.
- It is possible to deliver a drug directly to a specific cell in the body by designing the surface of a nanoparticle.
- Nanoparticles of a few nanometers size may reach well inside biomolecules, which is not possible for larger nanoparticles.
- Nanoparticles can also cross cell membranes.
- The inhaled nanoparticles reach the blood and that may also reach other sites such as the liver, heart or blood cells.
- Robotics is an integrated study of mechanical engineering, electronic engineering, computer engineering, and science.
- Robot is a mechanical device designed with electronic circuitry and programmed to perform a specific task.
- The robotic system mainly consists of sensors, power supplies, control systems, manipulators and necessary software.



- The key components of a robot are Power conversion unit, Actuators, Electric motors, Pneumatic Air Muscles, Muscle wires, Piezo Motors and Ultrasonic Motors, Sensors, and Robot locomotion.
- Six main types of industrial robots are Cartesian, SCARA, Cylindrical, Delta, Polar and Vertically articulated robot.
- Six-axis robots are ideal for Arc Welding, Spot Welding, Material Handling, Machine Tending.
- Five major fields of robotics: Human-robot interface, Mobility, Manipulation, Programming and Sensors.
- The aim of artificial intelligence is to bring in human like behavior in robots.
- Artificial intelligence works on face recognition, providing response to players' actions in computer games, taking decisions based on previous actions, regulating the traffic by analyzing the density of traffic on roads and translate words from one language to another.
- Materials used to make robots: aluminum and steel are the most common metals.
- Aluminum is a softer metal and is therefore easier to work with.
- Steel is several times stronger.
- Due to the inherent strength of metal, robot bodies can be made using sheet, bar, rod, channel, and other shapes.
- Robots have many advantages in various applications but also have several disadvantages.
- In outer space robots are used for exploring stars, planets etc., investigation of the mineralogy of the rocks and soils on Mars, analysis of elements found in rocks and soils.
- Household robots are used as vacuum cleaners, floor cleaners, gutter cleaners, lawn mowing, pool cleaning, and to open and close doors.
- Industrial Robots are used for welding, cutting, robotic water jet cutting, robotic laser cutting, lifting, sorting, bending, manufacturing, assembling, packing, transport, handling hazardous materials like nuclear waste, weaponry, laboratory research, mass production of consumer and industrial goods.
- Nano-robots are being developed to be in the blood stream to perform small surgical procedures, to fight against bacteria, repairing individual cell in the body.
- The development in medical field has been proportional to the evolution of physics.
- The recent medical technology includes virtual reality, precision medicine, health wearables, artificial organs, 3D printing, wireless brain sensors, robotic surgery, smart inhalers.
- Particle physics deals with fundamental particles of nature. Protons and neutrons are made of quarks.
- Cosmology is the branch that involves the origin and evolution of the universe.
- Accelerated mass emits gravitational waves which are very weak.
- Black holes are the strongest source of gravitational waves.



CONCEPT MAP

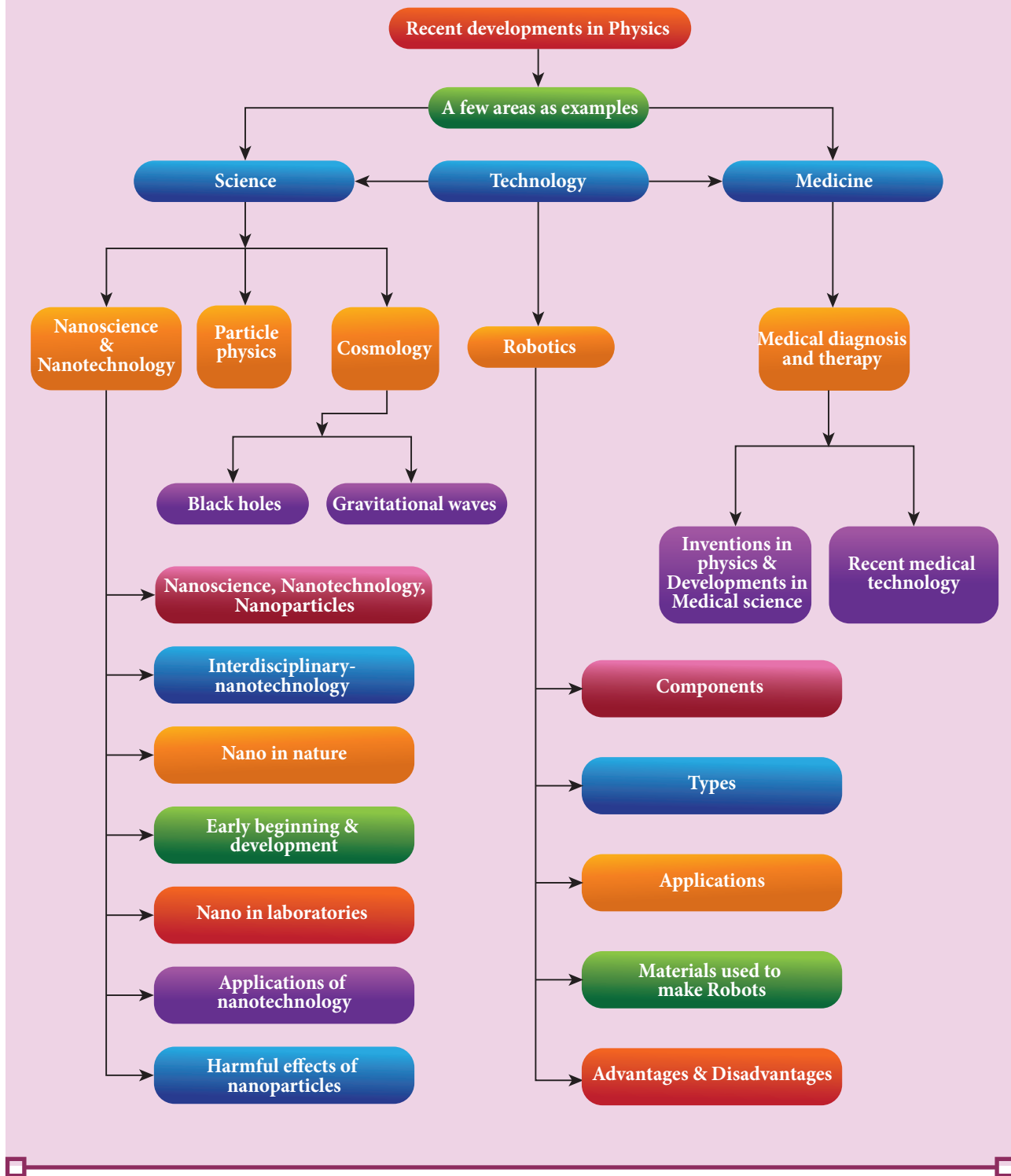

**I Multiple Choice Questions**

1. The particle size of ZnO material is 30 nm. Based on the dimension it is classified as
 - a) Bulk material
 - b) Nanomaterial
 - c) Soft material
 - d) Magnetic material
2. Which one of the following is the natural nanomaterial.
 - a) Peacock feather
 - b) Peacock beak
 - c) Grain of sand
 - d) Skin of the Whale
3. The blue print for making ultra durable synthetic material is mimicked from
 - a) Lotus leaf
 - b) Morpho butterfly
 - c) Parrot fish
 - d) Peacock feather
4. The method of making nanomaterial by assembling the atoms is called
 - a) Top down approach
 - b) Bottom up approach
 - c) Cross down approach
 - d) Diagonal approach
5. "Sky wax" is an application of nano product in the field of
 - a) Medicine
 - b) Textile
 - c) Sports
 - d) Automotive industry



6. The materials used in Robotics are
 - a) Aluminium and silver
 - b) Silver and gold
 - c) Copper and gold
 - d) Steel and aluminum
7. The alloys used for muscle wires in Robots are
 - a) Shape memory alloys
 - b) Gold copper alloys
 - c) Gold silver alloys
 - d) Two dimensional alloys
8. The technology used for stopping the brain from processing pain is
 - a) Precision medicine
 - b) Wireless brain sensor
 - c) Virtual reality
 - d) Radiology
9. The particle which gives mass to protons and neutrons are
 - a) Higgs particle
 - b) Einstein particle
 - c) Nanoparticle
 - d) Bulk particle
10. The gravitational waves were theoretically proposed by
 - a) Conrad Rontgen
 - b) Marie Curie
 - c) Albert Einstein
 - d) Edward Purcell

Answers

- 1) b 2) a 3) c 4) b 5) c
6) d 7) a 8) c 9) a 10) c

II Short answers

1. Distinguish between Nanoscience and Nanotechnology.
2. What is the difference between Nano materials and Bulk materials?
3. Give any two examples for “Nano” in nature.
4. Mention any two advantages and disadvantages of Robotics.
5. Why steel is preferred in making Robots?
6. What are black holes?
7. What are sub atomic particles?

III Long Answers

1. Discuss the applications of Nanomaterials in various fields.
2. What are the possible harmful effects of usage of Nanoparticles? Why?
3. Discuss the functions of key components in Robots?
4. Elaborate any two types of Robots with relevant examples.
5. Comment on the recent advancement in medical diagnosis and therapy.

BOOKS FOR REFERENCE

1. Pradeep, T. Nano Essential Understanding Nano Science and Nanotechnology, McGraw Hill Education, India 2007.
2. Rita John, Solid State Physics, McGraw Hill Education, India 2016
3. Asim K Das, Mahua Das, An Introduction to Nano Science and Nano technology, CBS Publishers and Distributors Pvt Ltd, India 2017.
4. Jerrold T. Bushberg, J. Anthony Seibert, The Essential Physics of Medical Imaging, Wolters Kluwer, Lippin Cott Williams & Wilkins 2012
5. Brian R Martin, Particle Physics, Kindle edition, 2011
6. B S Murty, P Shankar, Baldev Raj, B B Rath, James Murday, Textbook of Nanoscience and Nanotechnology, Springer, Universities Press, 2013



ICT CORNER

Recent developments in physics

In this activity you will be able to (i) observe the changes in the nuclear spins of the hydrogen nuclei of your water molecules due to the external magnetic field (ii) find out the resonance frequency that promote a resultant photon.

Topic: MRI scan

STEPS:

- Go to '<https://phet.colorado.edu/en/simulation/legacy/mri>' page and download simplified MRI java file. Or go to Google → Phet → simulation → Physics → simplified MRI and download the java file.
- Open simplified MRI java file. Select simplified MRI tab.
- Observe the nuclear spins of the hydrogen nuclei present in the water molecules in brain (blue is the hydrogen nuclei). Are they aligned in same direction? What happens when you change the external magnetic field? Are they aligned in the same direction under external field? Discuss the reason.
- Now adjust the frequency bar. For a particular frequency, hydrogen nuclei emit radio waves from left to right and find out the frequency when the nuclei start broadcasting radio waves. This is resonance frequency.
- Add a tumour. Adjust the resonance frequency slightly to produce the strongest signal from the tumour. Record the tumour resonance frequency. Is there a shift?
- With the help of shift in resonance frequency, tumour inside the brain can be calculated.

Step1

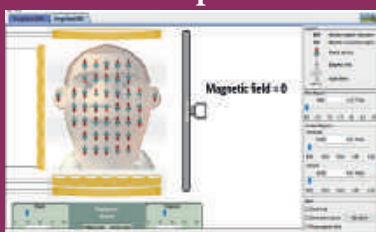

Step2

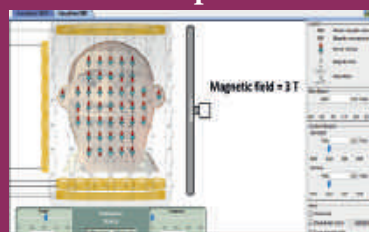

Step3



Step4



Note:

Install Java application if it is not in your browser.

URL:

<https://phet.colorado.edu/en/simulation/legacy/mri>

* Pictures are indicative only.

* If browser requires, allow **Flash Player** or **Java Script** to load the page.



B263_12_PHYSICS_EM

GLOSSARY

கலைச்சொற்கள்



B6Q8H8

1. Acceptance angle - ஏற்புக்கோணம்
2. Acceptor energy level - ஏற்பு அணு ஆற்றல் மட்டம்
3. Activity - செயல்பாடு
4. Amplitude modulation - வீச்சுப் பண்பேற்றம்
5. Analyser - பகுப்பான்
6. Anti fouling coating - கறைபடியா மேற்பூச்சு
7. Anti particle - எதிர்த்துகள்
8. Apparent depth - தோற்ற ஆழம்
9. Astigmatism - ஒரு தளப்பார்வை
10. Attenuation - வலுவிழப்பு
11. Automotive industry - வாகனத் தொழில்
12. Auto-immune disease - நோய் எதிர்ப்பு சக்திக்கு எதிரான நோய்
13. Band gap energy - பட்டை இடைவெளி ஆற்றல்
14. Barrier potential - அரண் மின்னழுத்தம்
15. Baseband signal - அடிக்கற்றை சைகை
16. Biasing - சார்பளித்தல்
17. Binding energy - பிணைப்பாற்றல்
18. Bipolar junction transistor - இருமுனைச் சந்தி டிரான்சிஸ்டர்
19. Boolean Algebra - பூலியன் இயற்கணிதம்
20. Brain tumor - மூளைக்கட்டி
21. Bright fringe - பொலிவுப்பட்டை
22. Broadcasting station - ஒலிபரப்பும் நிலையம்
23. Carrier concentration - ஊர்தி செறிவு
24. Carrier signal - ஊர்தி சைகை
25. Central bright fringe - மையப்பொலிவுப்பட்டை
26. Characteristic x-rays - சிறப்பு x கதிர்கள்
27. Chemical Vapour Deposition (CVD) - வேதிவினை நீராவி படிவு (அ) வேதி ஆவி படிமமாக்கல்
28. Classical electrodynamics - செவ்வியல் மின்னியக்கவியல்
29. Collector-base junction - ஏற்பான் - அடிவாய் சந்தி
30. Computed Tomography - கணினி வரைவி
31. Concave lens - குழிலென்ஸ்
32. Concave mirror - குழி அடி
33. Continuous x-rays - தொடர் x கதிர்கள்
34. Convex lens - குவிலென்ஸ்



35. Convex mirror	- குவி அடி
36. Critical angle	- மாறுநிலைக்கோணம்
37. Cut-off region	- முறிவுப் பகுதி
38. Dark fringe	- கரும்பட்டை
39. Decay mode	- சிதைவுப் பாணி
40. Depletion region	- இயக்கமில்லா பகுதி
41. Diffraction	- விளிம்புவிளைவு
42. Diffusion current	- விரவல் மின்னோட்டம்
43. Digital and analog signal	- இலக்கமுறை மற்றும் தொடர் சைகை
44. Discrete	- பிரிநிலை
45. Dispersion	- நிறப்பிரிகை
46. Distance of closest approach	- அணுகும் மீச்சிறு தொலைவு
47. Donor energy level	- கொடை அணு ஆற்றல் மட்டம்
48. Doping	- மாசூட்டல்
49. Drift current	- இழுப்பு மின்னோட்டம்
50. Droplet	- திவலை
51. Duality	- இருமைப்பண்பு
52. Dynamic resistance	- மாறு மின்தடை
53. Electron-hole recombination	- எலக்ட்ரான் - துளை மறு இணைவு
54. Electron current	- எலக்ட்ரான் மின்னோட்டம்
55. Electron emission	- எலக்ட்ரான் உமிழ்வு
56. Electrostatic lens	- நிலை மின்புல லென்ஸ்
57. Emitter-base junction	- உமிழ்ப்பான் - அடிவாய் சந்தி
58. Emitter current	- உமிழ்ப்பான் மின்னோட்டம்
59. Energy band diagram	- ஆற்றல் பட்டை வரைபடம்
60. Endoscopy	- அக உள்நோக்கி
61. Excitation energy	- கிளர்வு ஆற்றல்
62. Extrinsic	- புறவியலான
63. Feedback circuit	- பின்னூட்டச் சுற்று
64. Fiber optic communication	- ஒளி இழைத் தகவல் தொடர்பு
65. Field emission	- புல உமிழ்வு
66. Focal length	- குவியத்தொலைவு
67. Forward current gain	- முன்னோக்கு மின்னோட்டப்பெருக்கம்
68. Frequency modulation	- அதிர்வெண் பண்பேற்றம்
69. Fringe width	- பட்டை அகலம்
70. Fuel cell	- எரிபொருள் மின்கலன்
71. Glass slab	- கண்ணாடிப்பட்டகம்
72. Global Positioning System	- உலகளாவிய நிலை அறிவும் அமைப்பு
73. Ground State / excited state	- தரை நிலை / கிளர்ச்சி நிலை
74. Ground wave propagation	- தரை அலை பரவல்
75. Hole current	- துளை மின்னோட்டம்
76. Hypermetropia	- தூரப்பார்வை
77. Impact parameter	- மோதல் காரணி
78. Impurity atoms	- மாசு அணுக்கள்





79. Interference	- குறுக்கீட்டு விளைவு
80. Intrinsic	- உள்ளார்ந்த
81. Knee voltage	- பயன்தொடக்க மின்னழுத்தம்
82. Light emitting diode	- ஒளி உமிழ் டையோடு
83. Line of sight communication	- நேர்க்கோட்டுப்பார்வை தகவல் தொடர்பு
84. Load current	- பளு மின்னோட்டம்
85. Load resistance	- பளு மின்தடை
86. Logic gates	- தர்க்க வாய்க்கால்கள் (லாஜிக் கேட்டுகள்)
87. Looming	- நிழல் தோற்றம்
88. Magnetic lens	- காந்தப் புலலென்ஸ்
89. Magnification	- உருப்பெருக்கம்
90. Majority charge carriers	- பெரும்பான்மை மின்னூட்ட ஊர்திகள்
91. Marginal rays	- ஓரக்கதிர்கள்
92. Matter waves	- பருப்பொருள் அலைகள்
93. Maximum secondary voltage	- பெரும துணை மின்னழுத்தம்
94. Minority charge carriers	- சிறுபான்மை மின்னூட்ட ஊர்திகள்
95. Mirage	- கானல் நீர்
96. Mobile communication	- செல் பேசி தகவல் தொடர்பு
97. Moderator	- தணிப்பான்
98. Myopia	- கிட்டப்பார்வை
99. Near point focusing	- அண்மைக் குவி நிலை
100. Negative space charge region	- எதிர்மின்திரள் பகுதி
101. Normal focusing	- இயல்பு குவி நிலை
102. Nuclear fission	- அணுக்கரு பிளவு
103. Nuclear fusion	- அணுக்கரு இணைவு
104. Optical fiber	- ஒளிஇழை
105. Optoelectronic devices	- ஒளியியல் மின்னணு சாதனங்கள்
106. Paraxial rays	- அண்மை அச்சக்கதிர்கள்
107. Peak inverse voltage	- பெரும புரட்டு மின்னழுத்தம்
108. Phase	- கட்டம்
109. Phase modulation	- கட்டப் பண்பேற்றம்
110. Photo conductive cell	- ஒளிமின் கடத்து மின்கலம்
111. Photoelectric emission	- ஒளிமின் உமிழ்வு
112. Photoelectrons	- ஒளி எலக்ட்ரான்கள்
113. Photo emissive cell	- ஒளிமின் உமிழ்வு மின்கலம்
114. Photosensitive material	- ஒளி உணர் பொருள்
115. Photosensitive materials	- ஒளி நுண் உணர்வு பொருட்கள்
116. Photo voltaic cell	- ஒளி வோல்டா மின்கலம்
117. Polariser	- தளவிளைவாக்கி
118. Polarization	- தளவிளைவு
119. Positive and negative logic	- நேர் மற்றும் எதிர் தர்க்கம்
120. Positive space charge region	- நேர் மின்திரள் பகுதி
121. Potential barrier	- மின்னழுத்த அரண்
122. Power of lens	- லென்சின் திறன்





123. Presbyopia	- வெள்ளெழுத்து
124. Prism	- முப்பட்டகம்
125. Prosthetics	- செயற்கைமூட்டு
126. Pulsating output	- துடிப்பு வெளியீடு
127. Quantization	- குவாண்டமாக்கல்
128. Radioactive recombination	- கதிர்வீச்சு மறுஇணைவு
129. Radio isotope imaging	- கதிர்வீச்சு ஐசோடோப்பு பிம்பம்
130. Radiology	- கதிரியக்கச் சிகிச்சை
131. Radiology X-ray imaging	- கதிரியக்க ஊடுகதிர் பிம்பம்
132. Rectification	- திருத்துதல்
133. Rectifier efficiency	- திருத்தியின் பயனுறுதிறன்
134. Reflection	- ஒளி எதிரொளிப்பு
135. Refraction	- ஒளிவிலகல்
136. Refractive Index	- ஒளிவிலகல் எண்
137. Repeater	- மறு ஒலிபரப்பி
138. Resolution	- பிரித்தறிதல்
139. Resolving Power	- பிரித்திறன்
140. Reverse saturation current	- பின்னோக்கு செறிவு மின்னோட்டம்
141. Robot	- இயந்திர மனிதன்
142. Robotic surgery	- இயந்திரமனித அறுவைசிகிச்சை
143. Scanning Tunneling Microscope (STM)	- துளைக்கும் வரிக்கண்ணோட்ட நுண்ணோக்கி
144. Scattering	- ஒளிச்சிதறல்
145. Secondary emission	- இரண்டாம் நிலை உமிழ்வு
146. Sensor	- உணர்வி
147. Skip distance	- தாவுத் தொலைவு
148. Skip zone	- தாவு மண்டலம்
149. Sky wave propagation	- வான் அலை பரவல்
150. Space wave propagation	- வெளி அலை பரவல்
151. Specific Charge	- மின்னூட்ட எண்
152. Stopping potential	- நிறுத்து மின்னழுத்தம்
153. Surface barrier	- பரப்பு அரண்
154. Thermionic emission	- வெப்பஅயனி உமிழ்வு
155. Threshold frequency	- பயன்தொடக்க அதிர்வெண்
156. Total Internal reflection	- முழு அக எதிரொளிப்பு
157. Transmitting antenna	- பரப்பும் விண்ணலைக்கம்பி
158. Wavefront	- அலைமுகப்பு
159. Wireless brain sensor	- கம்பியில்லா மூளை உணர்வி
160. Work function	- வெளியேற்று ஆற்றல்



Solved examples



Competitive Exam corner

State Council of Educational Research and Training, Chennai-6
Higher Secondary Second Year Physics volume 2
List of Subject Experts in Textbook Writing

Domain Expert & Mentor

Prof. Dr. Rita John

Professor and Head
Department of Theoretical physics,
University of madras, Chennai.

Reviewers

Dr. V. N. Mani

Principal Scientist F, Head (C-MET)
Department of Electronics &
Information Technology, Hyderabad,
Government of India.

Prof. P. Ravindran

Department of Physics,
School of Basic and Applied Sciences,
Central University of Tamil Nadu,
Thiruvavur.

Dr. Rajeev shesha Joshi

Assistant Professor,
School of Physical Sciences,
Central University of Karnataka.

Content Writers

Prof. Dr. Rita John

Professor and Head
Department of Theoretical physics,
University of madras, Chennai.

Dr. P. Balamurugan

Assistant Professor,
PG and Research Department of Physics,
Government Arts College for Men
Nandanam, Chennai.

Dr. R. Sugaraj Samuel

Assistant Professor,
PG and Research Department of Physics,
The New College,
Royapettah, Chennai.

Mr. C. Joseph Prabagar

Assistant Professor,
PG and Research Department of Physics,
Loyola College, Chennai

Dr. S. S. Naina Mohammed

Assistant Professor,
PG and Research Department of Physics,
Government Arts College
Udumalpet, Tiruppur District.

Dr. P. Elangovan

Assistant Professor,
PG and Research Department of Physics,
Pachaiyappa's College,
Chennai.

Dr. B. Benita Merlin

Assistant Professor,
Alpha Arts and Science College,
Chennai

Tamil Translators

Mr.E.Elangovan

Head Master,
Government Hr Sec School
Ramanayakanpetai,
Vellore District.

Dr.K.Vasudevan

PGT, Government ADW.Hr.Sec.School
Kalangani
Namakkal District.

Mr. V.Balamurugan

PG Assistant in Physics,
Government Hr.Sec.School,
Kadambattur,
Tiruvallur District

Mr. S. Ravishankar

PG Assistant in Physics,
S.R.M. Hr. Sec. School,
Ambattur,
Tiruvallur District

SCERT Subject Coordinator

Mrs. P.Nantha

Senior Lecturer
SCERT, Chennai – 06.

ICT Coordinator

Mr.G.Bergin

PG Assistant (Physics)
GBHSS, Sayalkudi,
Ramanathapuram District.

QR CODE Management Team

R. Jaganathan

SGT, PUMS - Ganesapuram,
Polur , Thiruvannamalai.

A. Devi Jesintha

B.T. Asst., GHS, N.M. Kovil,
Thirupathur, Vellore

V. Padmavathi, B.T,

B.T. Asst., GHS, Vettriyur, Thirumanur,
Ariyalur Dist.

Art and Design Team

Layout

V. Sridhar, B. Yogesh, C. Prasanth
Asker ali

In-house QC

Jerald Wilson
Rajesh Thangappan

Illustration

K. Sasi Kumar
S. Durga Devi
V. Vinothkumar

Cover Design

Kathir Arumugam

Co-ordination

Ramesh Munisamy

This book has been printed on 80 G.S.M.
Elegant Maplitho paper.
Printed by offset at:



NOTES



NOTES



NOTES



NOTES