

DATE : 03/10/2021



Corporate Office : Aakash Tower, 8, Pusa Road, New Delhi-110005
Ph.: 011-47623456 Fax : 011-47623472

Time : 3 hrs.

Answers & Solutions

for

JEE (Advanced)-2021

Max. Marks: 180

PAPER - 1

PART-I : PHYSICS

SECTION - 1

- This section contains **FOUR (04)** questions.
- Each question has **FOUR** options (A), (B), (C) and (D). **ONLY ONE** of these four options is the correct answer.
- For each question, choose the option corresponding to the correct answer.
- Answer to each question will be evaluated according to the following marking scheme:

Full Marks : +3 If **ONLY** the correct option is chosen;

Zero Marks : 0 If none of the options is chosen (i.e. the question is unanswered);

Negative Marks : -1 In all other cases.

1. The smallest division on the main scale of a Vernier calipers is 0.1 cm. Ten divisions of the Vernier scale correspond to nine divisions of the main scale. The figure below on the left shows the reading of this calipers with no gap between its two jaws. The figure on the right shows the reading with a solid sphere held between the jaws. The correct diameter of the sphere is

- (A) 3.07 cm
- (B) 3.11 cm
- (C) 3.15 cm
- (D) 3.17 cm

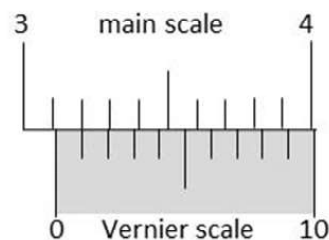
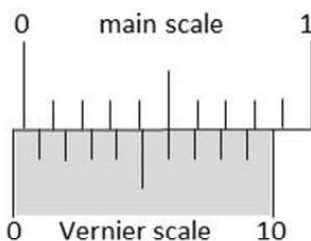

Answer (C)

Sol. Least count of Vernier calipers = 0.01 cm

$$\begin{aligned} \text{Error in scale} &= 4 \text{ LC} \\ &= 0.04 \text{ cm} \\ \text{Reading} &= 3.1 \text{ cm} + 1 \text{ L.C} \\ &= 3.1 \text{ cm} + 0.01 \\ &= 3.11 \text{ cm} \end{aligned}$$

$$\begin{aligned} \text{So correct diameter of the sphere} & \\ &= (3.11 + 0.04) \text{ cm} \\ &= 3.15 \text{ cm} \end{aligned}$$

So, option (C)

2. An ideal gas undergoes a four step cycle as shown in the $P - V$ diagram below. During this cycle, heat is absorbed by the gas in

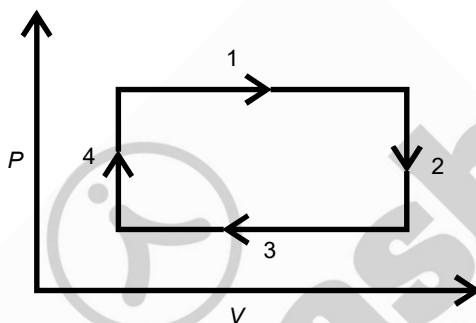

- (A) steps 1 and 2
- (B) steps 1 and 3
- (C) steps 1 and 4
- (D) steps 2 and 4

Answer (C)

Sol. Given $P - V$ diagram

For process (1)

$$\Delta Q_1 = nC_p \Delta T$$

As $P = \text{constant}$ and V increases

so T will increase

$$\text{So } \Delta Q_1 > 0$$

For process (2)

$$\Delta Q_2 = nC_v \Delta T$$

$V = \text{constant}$, $P \downarrow$, So $T \downarrow$

For process (3), $\Delta Q_3 = nC_p \Delta T < 0$

For process (4), $\Delta Q_4 = nC_p \Delta T$

As $\Delta T > 0$

$$\text{So } \Delta Q_4 > 0$$

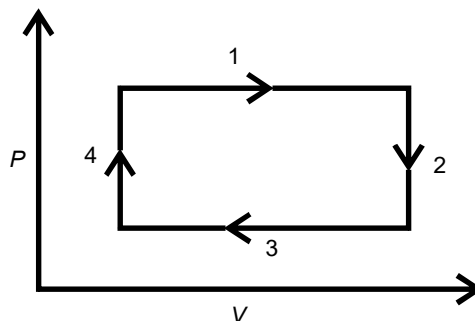

3. An extended object is placed at point O, 10 cm in front of a convex lens L_1 and a concave lens L_2 is placed 10 cm behind it, as shown in the figure. The radii of curvature of all the curved surfaces in both the lenses are 20 cm. The refractive index of both the lenses is 1.5. The total magnification of this lens system is

- (A) 0.4
(B) 0.8
(C) 1.3
(D) 1.6

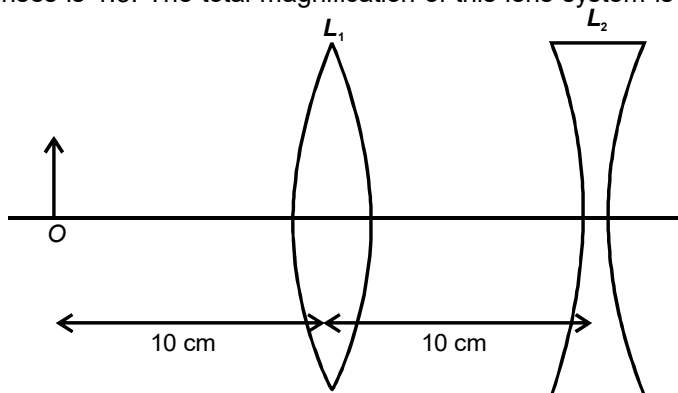

Answer (B)

Sol. $\frac{1}{v_1} - \frac{1}{-10} = \frac{1}{20}$

$$\Rightarrow \frac{1}{v_1} = \frac{1}{20} - \frac{1}{10} = \frac{-1}{20}$$

$$\Rightarrow v_1 = -20 \text{ cm}$$

$$m_1 = \frac{v}{u} = \frac{-20}{-10} = 2$$

again $\frac{1}{v_2} - \frac{1}{-30} = \frac{1}{-20}$

$$\Rightarrow \frac{1}{v_2} = -\frac{1}{30} - \frac{1}{20} = -\frac{5}{60} = -\frac{1}{12}$$

$$m_2 = -\frac{12}{-30} = \frac{2}{5}$$

$$m = m_1 \times m_2 = 2 \times \frac{2}{5} = 0.8$$

4. A heavy nucleus Q of half-life 20 minutes undergoes alpha-decay with probability of 60% and beta-decay with probability of 40%. Initially, the number of Q nuclei is 1000. The number of alpha-decays of Q in the first one hour is

- (A) 50
(B) 75
(C) 350
(D) 525

Answer (D)

Sol: $t_{1/2} = 20$ min

In 60 min, no. of half-life = 3

$$\Rightarrow N_A = \left[1000 - \frac{1000}{2^3} \right] \times 0.6$$

$$= 1000 \times \frac{7}{8} \times 0.6$$

$$= 525$$

SECTION - 2

- This section contains **THREE (03)** question stems.
- There are **TWO (02)** questions corresponding to each question stem.
- The answer to each question is a **NUMERICAL VALUE**.
- For each question, enter the correct numerical value corresponding to the answer in the designated place using the mouse and the on-screen virtual numeric keypad.
- If the numerical value has more than two decimal places, **truncate/round-off** the value to **TWO** decimal places.
- Answer to each question will be evaluated according to the following marking scheme:

Full Marks : +2 If ONLY the correct numerical value is entered at the designated place;

Zero Marks : 0 In all other cases.

Question Stem for Question Nos. 5 and 6

Question Stem

A projectile is thrown from a point O on the ground at an angle 45° from the vertical and with a speed $5\sqrt{2}$ m/s. The projectile at the highest point of its trajectory splits into two equal parts. One part falls vertically down to the ground, 0.5 s after the splitting. The other part, t seconds after the splitting, falls to the ground at a distance x meters from the point O. The acceleration due to gravity $g = 10$ m/s².

5. The value of t is _____.

Answer (00.50)

Sol. $H = \frac{u^2 \sin^2 \theta}{2g}$

$$= \frac{50}{2 \times 10} \times \frac{1}{2} = \frac{5}{4}$$

$$t = \sqrt{\frac{2H}{g}} = \sqrt{\frac{2 \times 5}{4 \times 10}}$$

$$t = \frac{1}{2} \text{ s} = 0.5 \text{ sec}$$

Ans. 00.50

6. The value of x is _____.

Answer (07.50)

Sol. $X = \frac{3R}{2}$ as $X_{cm} = R$

$$R = \frac{u^2 \sin^2 \theta}{g} = \frac{50}{10} = 5$$

$$\Rightarrow X = \frac{3R}{2} = \frac{15}{2} = 7.5 \text{ m}$$

Ans.: 07.50

Question Stem for Question Nos. 7 and 8

Question Stem

In the circuit shown below, the switch S is connected to position P for a long time so that the charge on the capacitor becomes $q_1 \mu\text{C}$. Then S is switched to position Q . After a long time, the charge on the capacitor is $q_2 \mu\text{C}$.

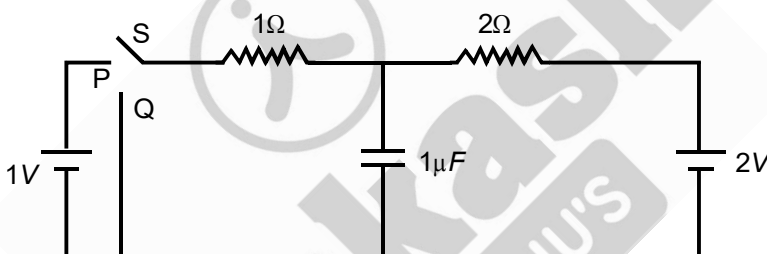

7. The magnitude of q_1 is _____.

Answer (01.33)

Sol. With switch S at position P after long time potential difference across capacitor branch

$$= \frac{\frac{2}{2} + \frac{1}{1}}{\frac{1}{2} + \frac{1}{1}} = \frac{2 \times 2}{3} = \frac{4}{3} \text{ V}$$

$$\Rightarrow \text{Charge on capacitor } q_1 \mu\text{C} = \frac{4}{3} \mu\text{C}$$

$$\Rightarrow q_1 = \frac{4}{3} = 1.33$$

8. The magnitude of q_2 is _____.

Answer (00.67)

Sol. With switch S at position Q after long time potential difference across capacitor

= potential difference across resistance of 1 ohm.

$$= \frac{2}{3} \text{ V}$$

$$\Rightarrow \text{charge on capacitor } q_2 \mu\text{C} = \frac{2}{3} \mu\text{C}$$

$$\Rightarrow q_2 = 0.67$$

Question Stem for Question Nos. 9 and 10

Question Stem

Two point charges $-Q$ and $+Q/\sqrt{3}$ are placed in the xy -plane at the origin $(0, 0)$ and a point $(2, 0)$, respectively, as shown in the figure. This results in an equipotential circle of radius R and potential $V = 0$ in the xy -plane with its center at $(b, 0)$. All lengths are measured in meters.

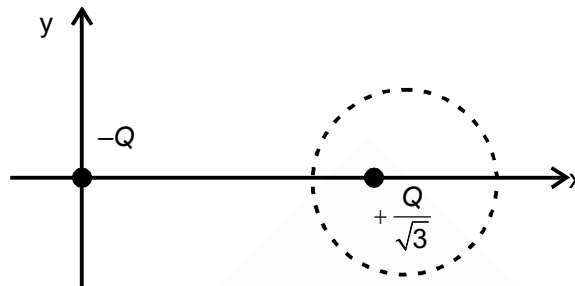

9. The value of R is ___ meter

Answer ($R = 01.73$)

10. The value of b is ___ meter

Answer ($b = 03.00$)

Solution for Q. Nos. 9 & 10

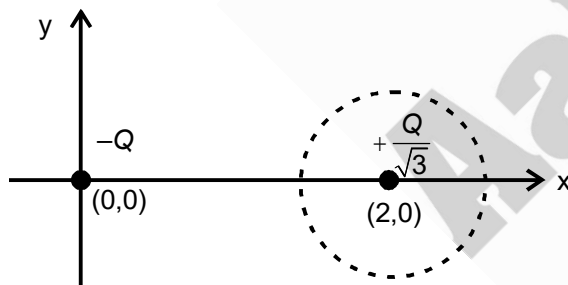

$$V(x, y) = \frac{1}{4\pi\epsilon_0} \left(-\frac{Q}{\sqrt{x^2 + y^2}} + \frac{Q}{\sqrt{3}\sqrt{(x-2)^2 + y^2}} \right)$$

$$\Rightarrow 3(x-2)^2 + 3y^2 = x^2 + y^2$$

$$\Rightarrow (x-3)^2 + y^2 = (\sqrt{3})^2$$

SECTION - 3

- This section contains **SIX (06)** questions.
- Each question has **FOUR** options (A), (B), (C) and (D). **ONE OR MORE THAN ONE** of these four option(s) is (are) correct answer(s).
- For each question, choose the option(s) corresponding to (all) the correct answer(s).

- Answer to each question will be evaluated according to the following marking scheme:

Full Marks : +4 If only (all) the correct option(s) is(are) chosen;

Partial Marks : +3 If all the four options are correct but ONLY three options are chosen;

Partial Marks : +2 If three or more options are correct but ONLY two options are chosen, both of which are correct;

Partial Marks : +1 If two or more options are correct but ONLY one option is chosen and it is a correct option;

Zero Marks : 0 If unanswered;

Negative Marks : - 2 In all other cases.

- For example, in a question, if (A), (B) and (D) are the ONLY three options corresponding to correct answers, then

Choosing ONLY (A), (B) and (D) will get +4 marks;

Choosing ONLY (A) and (B) will get +2 marks;

Choosing ONLY (A) and (D) will get +2 marks;

Choosing ONLY (B) and (D) will get +2 marks;

Choosing ONLY (A) will get +1 mark;

Choosing ONLY (B) will get +1 mark;

Choosing ONLY (D) will get +1 mark;

Choosing no option(s) (i.e. the question is unanswered) will get 0 marks and choosing any other option(s) will get "2 marks.

11. A horizontal force F is applied at the center of mass of a cylindrical object of mass m and radius R , perpendicular to its axis as shown in the figure. The coefficient of friction between the object and the ground is μ . The center of mass of the object has an acceleration a . The acceleration due to gravity is g . Given that the object rolls without slipping, which of the following statement(s) is(are) correct?

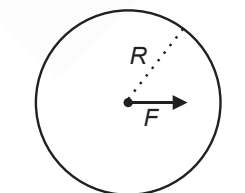

- (A) For the same F , the value of a does not depend on whether the cylinder is solid or hollow
- (B) For a solid cylinder, the maximum possible value of a is $2\mu g$
- (C) The magnitude of the frictional force on the object due to the ground is always μmg
- (D) For a thin-walled hollow cylinder, $a = \frac{F}{2m}$

Answer (B, D)

Sol. For solid cylinder,

$$F \times R = \frac{3}{2} m R^2 \times \left(\frac{a}{R} \right)$$

$$\Rightarrow a = \frac{2F}{3m}$$

For hollow cylinder,

$$F \times R = (2mR^2) \times \frac{a}{R}$$

$$\Rightarrow a = \frac{F}{2m}$$

For solid cylinder

$$f = F - m \times \frac{2F}{3m} = \frac{F}{3} \leq \mu mg$$

$$\Rightarrow F \leq 3\mu mg$$

$$\therefore a \leq \frac{2}{3m} \times (3\mu mg)$$

$$\Rightarrow a_{\max} = 2\mu g$$

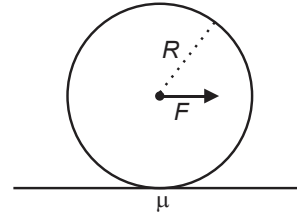

12. A wide slab consisting of two media of refractive indices n_1 and n_2 is placed in air as shown in the figure. A ray of light is incident from medium n_1 to n_2 at an angle θ , where $\sin \theta$ is slightly larger than $\frac{1}{n_1}$. Take refractive index of air as 1. Which of the following statement(s) is(are) correct?

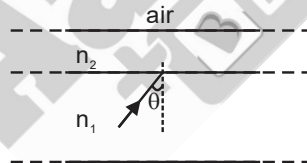

- (A) The light ray enters air if $n_2 = n_1$
- (B) The light ray is finally reflected back into the medium of refractive index n_1 if $n_2 < n_1$
- (C) The light ray is finally reflected back into the medium of refractive index n_1 if $n_2 > n_1$
- (D) The light ray is reflected back into the medium of refractive index n_1 if $n_2 = 1$

Answer (B, C, D)

Sol. $\sin \theta > \frac{1}{n_1}$... (i)

and, $n_1 \sin \theta = 1 \times \sin r$... (ii)

$\Rightarrow \sin r > 1$

\Rightarrow refraction into air is not possible.

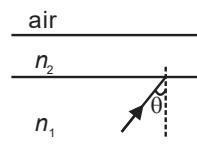

13. A particle of mass $M = 0.2$ kg is initially at rest in the xy -plane at a point $(x = -l, y = -h)$, where $l = 10$ m and $h = 1$ m. The particle is accelerated at time $t = 0$ with a constant acceleration $a = 10$ m/s² along the positive x -direction. Its angular momentum and torque with respect to the origin, in SI units, are represented by \vec{L} and $\vec{\tau}$, respectively. \hat{i} , \hat{j} and \hat{k} are unit vectors along the positive x , y and z -directions respectively. If $\hat{k} = \hat{i} \times \hat{j}$ then which of the following statement(s) is(are) correct?
- (A) The particle arrives at the point $(x = l, y = -h)$ at time $t = 2$ s
- (B) $\vec{\tau} = 2\hat{k}$ when the particle passes through the point $(x = l, y = -h)$
- (C) $\vec{L} = 4\hat{k}$ when the particle passes through the point $(x = l, y = -h)$
- (D) $\vec{\tau} = \hat{k}$ when the particle passes through the point $(x = 0, y = -h)$

Answer (A, B, C)

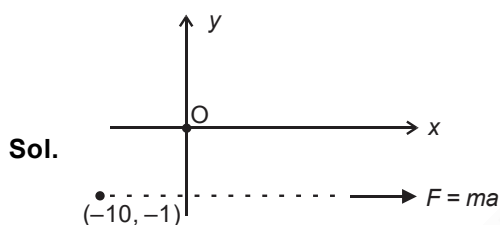

$$t = \sqrt{\frac{2 \times (20)}{10}} = 2\text{ s}$$

$$\vec{\tau} = (0.2 \times 10 \times 1) \hat{k} = 2\hat{k}$$

$$\vec{L} = [0.2 \times (10 \times 2) \times 1] \hat{k} = 4\hat{k}$$

14. Which of the following statement(s) is(are) correct about the spectrum of hydrogen atom?
- (A) The ratio of the longest wavelength to the shortest wavelength in Balmer series is $\frac{9}{5}$
- (B) There is an overlap between the wavelength ranges of Balmer and Paschen series
- (C) The wavelengths of Lyman series are given by $\left(1 + \frac{1}{m^2}\right)\lambda_0$, where λ_0 is the shortest wavelength of Lyman series and m is an integer
- (D) The wavelength ranges of Lyman and Balmer series do not overlap

Answer (A, D)

Sol. For Balmer series :

$$\frac{1}{\lambda} = R \left(\frac{1}{2^2} - \frac{1}{n^2} \right) \quad n = 3, 4, 5, \dots$$

$$\frac{1}{\lambda_{\max}} = R \left(\frac{1}{4} - \frac{1}{9} \right)$$

$$\frac{1}{\lambda_{\min}} = R \left(\frac{1}{4} \right)$$

$$\Rightarrow \frac{\lambda_{\max}}{\lambda_{\min}} = \frac{9}{5}$$

For Lyman series

$$\frac{1}{\lambda} = R \left(1 - \frac{1}{n^2} \right) \quad n = 2, 3, 4, \dots$$

$$\frac{1}{\lambda_{\min}} = R$$

$$\Rightarrow \lambda = \frac{\lambda_0 n^2}{n^2 - 1}$$

15. A long straight wire carries a current, $I = 2$ ampere. A semi-circular conducting rod is placed beside it on two conducting parallel rails of negligible resistance. Both the rails are parallel to the wire. The wire, the rod and the rails lie in the same horizontal plane, as shown in the figure. Two ends of the semi-circular rod are at distances 1 cm and 4 cm from the wire. At time $t = 0$, the rod starts moving on the rails with a speed $v = 3.0$ m/s (see the figure).

A resistor $R = 1.4 \, \Omega$ and a capacitor $C_0 = 5.0 \, \mu\text{F}$ are connected in series between the rails. At time $t = 0$, C_0 is uncharged. Which of the following statement(s) is(are) correct? [$\mu_0 = 4\pi \times 10^{-7}$ SI units. Take $\ln 2 = 0.7$]

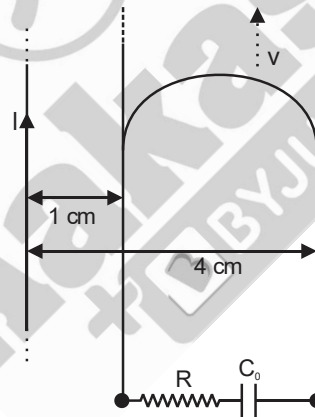

- (A) Maximum current through R is 1.2×10^{-6} ampere
- (B) Maximum current through R is 3.8×10^{-6} ampere
- (C) Maximum charge on capacitor C_0 is 8.4×10^{-12} coulomb
- (D) Maximum charge on capacitor C_0 is 2.4×10^{-12} coulomb

Answer (A, C)

Sol. Equivalent circuit of the given arrangement is :

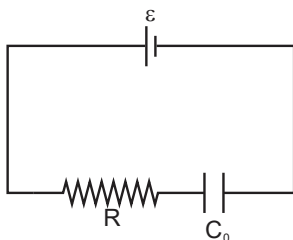

Where $\epsilon = \frac{\mu_0 IV}{2\pi} \ln \frac{b}{a}$

$= 1.68 \times 10^{-6} \text{ V}$

At $t = 0$, $i_{\text{max}} = \frac{\epsilon}{R} = \frac{1.68 \times 10^{-6}}{1.4} = 1.2 \times 10^{-6} \text{ A}$

At $t = \infty$, $q_{\text{max}} = C_0 \epsilon = 8.4 \times 10^{-12} \text{ C}$

16. A cylindrical tube, with its base as shown in the figure, is filled with water. It is moving down with a constant acceleration a along a fixed inclined plane with angle $\theta = 45^\circ$. P_1 and P_2 are pressures at points 1 and 2, respectively, located at the base of the tube. Let $\beta = \frac{(P_1 - P_2)}{(\rho g d)}$, where ρ is density of water, d is the inner diameter of the tube and g is the acceleration due to gravity. Which of the following statement(s) is(are) correct?

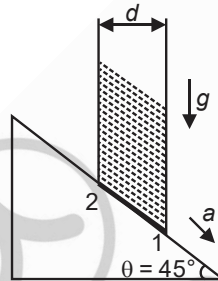

- (A) $\beta = 0$ when $a = \frac{g}{\sqrt{2}}$
- (B) $\beta > 0$ when $a = \frac{g}{\sqrt{2}}$
- (C) $\beta = \frac{\sqrt{2}-1}{\sqrt{2}}$ when $a = \frac{g}{2}$
- (D) $\beta = \frac{1}{\sqrt{2}}$ when $a = \frac{g}{2}$

Answer (A, C)

Sol. $P_1 = P_2 - \rho a \cos 45^\circ d + \rho(g - a \sin 45^\circ) d$

$\Rightarrow \frac{P_1 - P_2}{\rho g d} = 1 - \frac{\sqrt{2} a}{g}$

$\Rightarrow \beta = 0$ for $a = \frac{g}{\sqrt{2}}$

$\beta = \frac{\sqrt{2}-1}{\sqrt{2}}$ for $a = \frac{g}{2}$

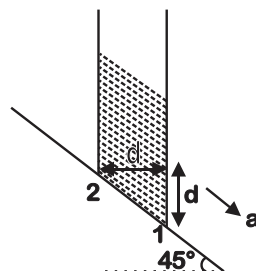

SECTION 4

- This section contains **THREE (03)** questions.
- The answer to each question is a **NON-NEGATIVE INTEGER**.
- For each question, enter the correct integer corresponding to the answer using the mouse and the on-screen virtual numeric keypad in the place designated to enter the answer.
- Answer to each question will be evaluated according to the following marking scheme:

Full Marks : +4 If ONLY the correct integer is entered

Zero Marks : 0 In all other cases.

17. An α -particle (mass 4 amu) and a singly charged sulfur ion (mass 32 amu) are initially at rest. They are accelerated through a potential V and then allowed to pass into a region of uniform magnetic field which is normal to the velocities of the particles. Within this region, the α -particle and the sulfur ion move in circular orbits of radii r_α and r_s , respectively. The ratio $\left(\frac{r_s}{r_\alpha}\right)$ is _____.

Answer (4)

Sol. $r = \frac{mv_0}{qB}$

$$\frac{1}{2}mv_0^2 = qV$$

$$r = \frac{\sqrt{2mqV}}{qB}$$

$$r = \frac{1}{B} \sqrt{\frac{2mV}{q}}$$

$$\frac{r_s}{r_\alpha} = \sqrt{\frac{m_s}{q_s}} \times \sqrt{\frac{q_\alpha}{m_\alpha}} = \sqrt{2} \times \sqrt{8}$$

$$\frac{r_s}{r_\alpha} = 4$$

18. A thin rod of mass M and length a is free to rotate in horizontal plane about a fixed vertical axis passing through point O . A thin circular disc of mass M and of radius $\frac{a}{4}$ is pivoted on this rod with its center at a distance $\frac{a}{4}$ from the free end so that it can rotate freely about its vertical axis, as shown in the figure. Assume that both the rod and the disc have uniform density and they remain horizontal during the motion. An outside stationary observer finds the rod rotating with an angular velocity Ω and the disc rotating about its vertical axis with angular velocity 4Ω . The total angular momentum of the system about the point O is $\left(\frac{Ma^2\Omega}{48}\right)^n$. The value of n is _____.

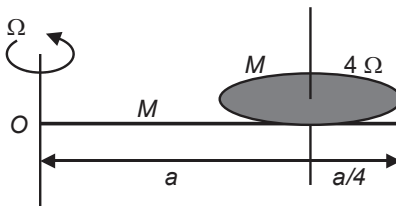

Answer (49)

Sol. $L_s = L_{\text{disc}} + L_{\text{rod}}$

$$L_{\text{disc}} = \vec{r} \times \vec{p} + I_{\text{cm}} 4\Omega$$

$$= \frac{Ma^2}{32} \times 4\Omega + \frac{3a}{4} \times \frac{3a}{4} \times M\Omega$$

$$= \frac{11}{16} Ma^2 \Omega$$

$$L_{\text{rod}} = \frac{Ma^2 \Omega}{3}$$

$$L_{\text{system}} = \left(\frac{Ma^2}{3} \Omega + \frac{11}{16} Ma^2 \Omega \right)$$

$$= \frac{49}{48} Ma^2 \Omega$$

n = 49

19. A small object is placed at the center of a large evacuated hollow spherical container. Assume that the container is maintained at 0 K. At time $t = 0$, the temperature of the object is 200 K. The temperature of the object becomes 100 K at $t = t_1$ and 50 K at $t = t_2$. Assume the object and the container to be ideal black bodies.

The heat capacity of the object does not depend on temperature. The ratio $\left(\frac{t_2}{t_1} \right)$ is _____.

Answer (9)

Sol. Heat radiated = $\epsilon\sigma AT^4$
 $= KT^4$

$$-mS \frac{dT}{dt} = KT^4$$

$$-mS \int_{200}^{100} \frac{dT}{T^4} = Kt_1$$

$$t_1 = \frac{1}{K_1} \left[\frac{1}{100^3} - \frac{1}{200^3} \right] = \frac{1}{K_1} \left[\frac{7}{200^3} \right]$$

$$t_2 = \frac{1}{K_1} \left[\frac{1}{50^3} - \frac{1}{200^3} \right] = \frac{1}{K_1} \left[\frac{63}{200^3} \right]$$

$$\frac{t_2}{t_1} = 9$$