

Exercise 6.5

Page: 150

1. Sides of triangles are given below. Determine which of them are right triangles? In case of a right triangle, write the length of its hypotenuse.

(i) 7 cm, 24 cm, 25 cm

(ii) 3 cm, 8 cm, 6 cm

(iii) 50 cm, 80 cm, 100 cm

(iv) 13 cm, 12 cm, 5 cm

Solution:

(i) Given, sides of the triangle are 7 cm, 24 cm, and 25 cm.

Squaring the lengths of the sides of the, we will get 49, 576, and 625.

$$49 + 576 = 625$$

$$(7)^2 + (24)^2 = (25)^2$$

Therefore, the above equation satisfies, Pythagoras theorem. Hence, it is right angled triangle.

Length of Hypotenuse = 25 cm

(ii) Given, sides of the triangle are 3 cm, 8 cm, and 6 cm.

Squaring the lengths of these sides, we will get 9, 64, and 36.

Clearly, $9 + 36 \neq 64$

$$\text{Or, } 3^2 + 6^2 \neq 8^2$$

Therefore, the sum of the squares of the lengths of two sides is not equal to the square of the length of the hypotenuse.

Hence, the given triangle does not satisfies Pythagoras theorem.

(iii) Given, sides of triangle's are 50 cm, 80 cm, and 100 cm.

Squaring the lengths of these sides, we will get 2500, 6400, and 10000.

However, $2500 + 6400 \neq 10000$

$$\text{Or, } 50^2 + 80^2 \neq 100^2$$

As you can see, the sum of the squares of the lengths of two sides is not equal to the square of the length of the third side.

Therefore, the given triangle does not satisfies Pythagoras theorem.

Hence, it is not a right triangle.

(iv) Given, sides are 13 cm, 12 cm, and 5 cm.

Squaring the lengths of these sides, we will get 169, 144, and 25.

$$\text{Thus, } 144 + 25 = 169$$

$$\text{Or, } 12^2 + 5^2 = 13^2$$

The sides of the given triangle are satisfying Pythagoras theorem.

Therefore, it is a right triangle.

Hence, length of the hypotenuse of this triangle is 13 cm.

2. PQR is a triangle right angled at P and M is a point on QR such that $PM \perp QR$. Show that $PM^2 = QM \times MR$.

Solution:

Given, ΔPQR is right angled at P is a point on QR such that $PM \perp QR$

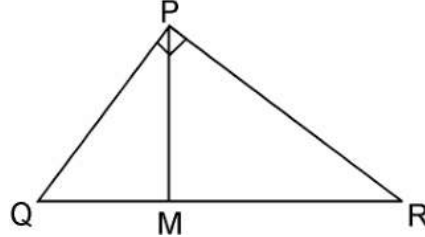

We have to prove, $PM^2 = QM \times MR$

In ΔPQM , by Pythagoras theorem

$$PQ^2 = PM^2 + QM^2$$

$$\text{Or, } PM^2 = PQ^2 - QM^2 \dots\dots\dots\text{(i)}$$

In ΔPMR , by Pythagoras theorem

$$PR^2 = PM^2 + MR^2$$

$$\text{Or, } PM^2 = PR^2 - MR^2 \dots\dots\dots\text{(ii)}$$

Adding equation, (i) and (ii), we get,

$$\begin{aligned} 2PM^2 &= (PQ^2 + PM^2) - (QM^2 + MR^2) \\ &= QR^2 - QM^2 - MR^2 \quad [\because QR^2 = PQ^2 + PR^2] \\ &= (QM + MR)^2 - QM^2 - MR^2 \\ &= 2QM \times MR \\ \therefore PM^2 &= QM \times MR \end{aligned}$$

3. In Figure, ABD is a triangle right angled at A and $AC \perp BD$. Show that

- (i) $AB^2 = BC \times BD$
- (ii) $AC^2 = BC \times DC$
- (iii) $AD^2 = BD \times CD$

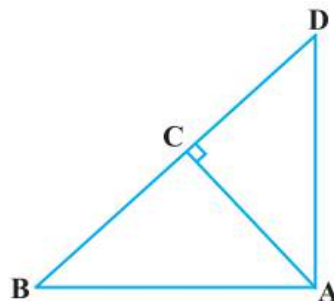

Solution:

(i) In $\triangle ADB$ and $\triangle CAB$,
 $\angle DAB = \angle ACB$ (Each 90°)
 $\angle ABD = \angle CBA$ (Common angles)
 $\therefore \triangle ADB \sim \triangle CAB$ [AA similarity criterion]
 $\Rightarrow AB/CB = BD/AB$
 $\Rightarrow AB^2 = CB \times BD$

(ii) Let $\angle CAB = x$
 In $\triangle CBA$,
 $\angle CBA = 180^\circ - 90^\circ - x$
 $\angle CBA = 90^\circ - x$
 Similarly, in $\triangle CAD$
 $\angle CAD = 90^\circ - \angle CBA$
 $= 90^\circ - x$
 $\angle CDA = 180^\circ - 90^\circ - (90^\circ - x)$
 $\angle CDA = x$

In $\triangle CBA$ and $\triangle CAD$, we have
 $\angle CBA = \angle CAD$
 $\angle CAB = \angle CDA$
 $\angle ACB = \angle DCA$ (Each 90°)
 $\therefore \triangle CBA \sim \triangle CAD$ [AAA similarity criterion]
 $\Rightarrow AC/DC = BC/AC$
 $\Rightarrow AC^2 = DC \times BC$

(iii) In $\triangle DCA$ and $\triangle DAB$,
 $\angle DCA = \angle DAB$ (Each 90°)
 $\angle CDA = \angle ADB$ (common angles)
 $\therefore \triangle DCA \sim \triangle DAB$ [AA similarity criterion]
 $\Rightarrow DC/DA = DA/DA$
 $\Rightarrow AD^2 = BD \times CD$

4. ABC is an isosceles triangle right angled at C. Prove that $AB^2 = 2AC^2$.

Solution:

Given, $\triangle ABC$ is an isosceles triangle right angled at C.

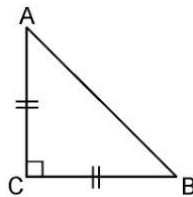

In $\triangle ACB$, $\angle C = 90^\circ$
 $AC = BC$ (By isosceles triangle property)

$$\begin{aligned}
 AB^2 &= AC^2 + BC^2 \text{ [By Pythagoras theorem]} \\
 &= AC^2 + AC^2 \text{ [Since, } AC = BC\text{]} \\
 AB^2 &= 2AC^2
 \end{aligned}$$

5. ABC is an isosceles triangle with $AC = BC$. If $AB^2 = 2AC^2$, prove that ABC is a right triangle.

Solution:

Given, ΔABC is an isosceles triangle having $AC = BC$ and $AB^2 = 2AC^2$

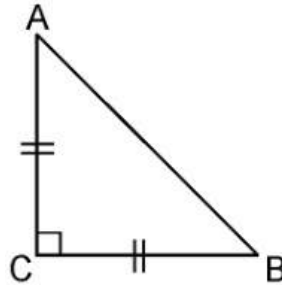

In ΔACB ,
 $AC = BC$
 $AB^2 = 2AC^2$
 $AB^2 = AC^2 + AC^2$
 $= AC^2 + BC^2$ [Since, $AC = BC$]
Hence, by Pythagoras theorem ΔABC is right angle triangle.

6. ABC is an equilateral triangle of side $2a$. Find each of its altitudes.

Solution:

Given, ABC is an equilateral triangle of side $2a$.

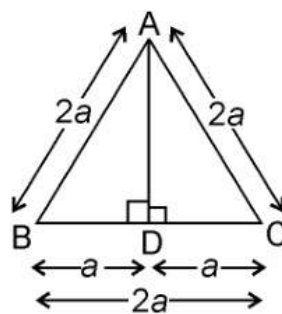

Draw, $AD \perp BC$
In ΔADB and ΔADC ,
 $AB = AC$
 $AD = AD$
 $\angle ADB = \angle ADC$ [Both are 90°]

Therefore, $\Delta ADB \cong \Delta ADC$ by RHS congruence.

Hence, $BD = DC$ [by CPCT]

In right angled $\triangle ADB$,
 $AB^2 = AD^2 + BD^2$
 $(2a)^2 = AD^2 + a^2$
 $\Rightarrow AD^2 = 4a^2 - a^2$
 $\Rightarrow AD^2 = 3a^2$
 $\Rightarrow AD = \sqrt{3}a$

7. Prove that the sum of the squares of the sides of rhombus is equal to the sum of the squares of its diagonals.

Solution:

Given, ABCD is a rhombus whose diagonals AC and BD intersect at O.

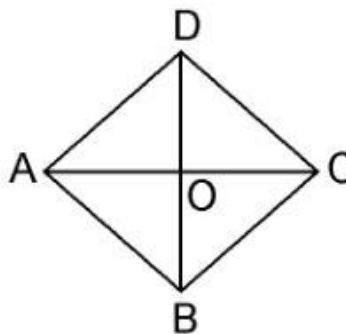

We have to prove, as per the question,
 $AB^2 + BC^2 + CD^2 + AD^2 = AC^2 + BD^2$

Since, the diagonals of a rhombus bisect each other at right angles.

Therefore, $AO = CO$ and $BO = DO$

In $\triangle AOB$,

$\angle AOB = 90^\circ$

$AB^2 = AO^2 + BO^2$ (i) [By Pythagoras theorem]

Similarly,

$AD^2 = AO^2 + DO^2$ (ii)

$DC^2 = DO^2 + CO^2$ (iii)

$BC^2 = CO^2 + BO^2$ (iv)

Adding equations (i) + (ii) + (iii) + (iv), we get,

$$\begin{aligned} AB^2 + AD^2 + DC^2 + BC^2 &= 2(AO^2 + BO^2 + DO^2 + CO^2) \\ &= 4AO^2 + 4BO^2 \text{ [Since, } AO = CO \text{ and } BO = DO\text{]} \\ &= (2AO)^2 + (2BO)^2 = AC^2 + BD^2 \end{aligned}$$

$$AB^2 + AD^2 + DC^2 + BC^2 = AC^2 + BD^2$$

Hence, proved.

8. In Fig. 6.54, O is a point in the interior of a triangle.

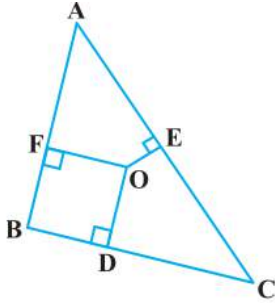

ABC , $OD \perp BC$, $OE \perp AC$ and $OF \perp AB$. Show that:

- (i) $OA^2 + OB^2 + OC^2 - OD^2 - OE^2 - OF^2 = AF^2 + BD^2 + CE^2$,
 (ii) $AF^2 + BD^2 + CE^2 = AE^2 + CD^2 + BF^2$.

Solution:

Given, in $\triangle ABC$, O is a point in the interior of a triangle.
 And $OD \perp BC$, $OE \perp AC$ and $OF \perp AB$.

Join OA , OB and OC

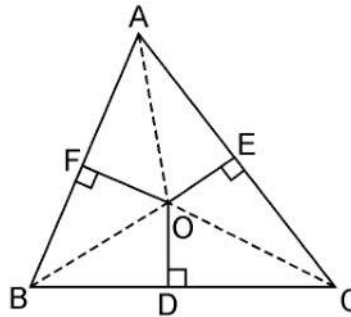

(i) By Pythagoras theorem in $\triangle AOF$, we have

$$OA^2 = OF^2 + AF^2$$

Similarly, in $\triangle BOD$

$$OB^2 = OD^2 + BD^2$$

Similarly, in $\triangle COE$

$$OC^2 = OE^2 + EC^2$$

Adding these equations,

$$OA^2 + OB^2 + OC^2 = OF^2 + AF^2 + OD^2 + BD^2 + OE^2 + EC^2$$

$$OA^2 + OB^2 + OC^2 - OD^2 - OE^2 - OF^2 = AF^2 + BD^2 + CE^2.$$

(ii) $AF^2 + BD^2 + EC^2 = (OA^2 - OE^2) + (OC^2 - OD^2) + (OB^2 - OF^2)$

$$\therefore AF^2 + BD^2 + CE^2 = AE^2 + CD^2 + BF^2.$$

9. A ladder 10 m long reaches a window 8 m above the ground. Find the distance of the foot of the ladder from base of the wall.

Solution:

Given, a ladder 10 m long reaches a window 8 m above the ground.

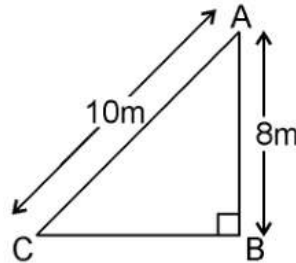

Let BA be the wall and AC be the ladder,

Therefore, by Pythagoras theorem,

$$AC^2 = AB^2 + BC^2$$

$$10^2 = 8^2 + BC^2$$

$$BC^2 = 100 - 64$$

$$BC^2 = 36$$

$$BC = 6\text{m}$$

Therefore, the distance of the foot of the ladder from the base of the wall is 6 m.

10. A guy wire attached to a vertical pole of height 18 m is 24 m long and has a stake attached to the other end. How far from the base of the pole should the stake be driven so that the wire will be taut?

Solution:

Given, a guy wire attached to a vertical pole of height 18 m is 24 m long and has a stake attached to the other end.

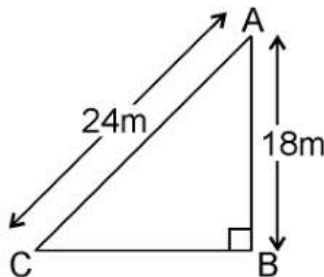

Let AB be the pole and AC be the wire.

By Pythagoras theorem,

$$AC^2 = AB^2 + BC^2$$

$$24^2 = 18^2 + BC^2$$

$$BC^2 = 576 - 324$$

$$BC^2 = 252$$

$$BC = 6\sqrt{7}\text{m}$$

Therefore, the distance from the base is $6\sqrt{7}\text{m}$.

11. An aeroplane leaves an airport and flies due north at a speed of 1,000 km per hour. At the same time, another aeroplane leaves the same airport and flies due west at a speed of 1,200 km per hour. How far apart will be the two planes after $1\frac{1}{2}$ hours?

Solution:

Given,

Speed of first aeroplane = 1000 km/hr

Distance covered by first aeroplane flying due north in $1\frac{1}{2}$ hours (OA) = $1000 \times \frac{3}{2}$ km = 1500 km

Speed of second aeroplane = 1200 km/hr

Distance covered by second aeroplane flying due west in $1\frac{1}{2}$ hours (OB) = $1200 \times \frac{3}{2}$ km = 1800 km

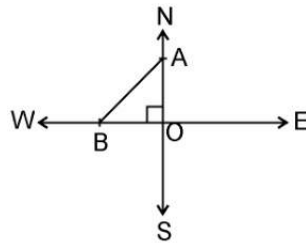

In right angle $\triangle AOB$, by Pythagoras Theorem,

$$AB^2 = AO^2 + OB^2$$

$$\Rightarrow AB^2 = (1500)^2 + (1800)^2$$

$$\Rightarrow AB = \sqrt{(2250000 + 3240000)}$$

$$= \sqrt{5490000}$$

$$\Rightarrow AB = 300\sqrt{61} \text{ km}$$

Hence, the distance between two aeroplanes will be $300\sqrt{61}$ km.

12. Two poles of heights 6 m and 11 m stand on a plane ground. If the distance between the feet of the poles is 12 m, find the distance between their tops.

Solution:

Given, Two poles of heights 6 m and 11 m stand on a plane ground.

And distance between the feet of the poles is 12 m.

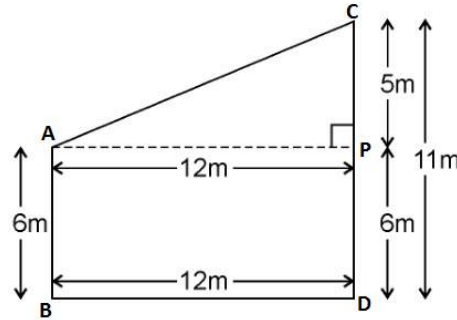

Let AB and CD be the poles of height 6m and 11m.
Therefore, $CP = 11 - 6 = 5\text{m}$

From the figure, it can be observed that $AP = 12\text{m}$

By Pythagoras theorem for ΔAPC , we get,

$$AP^2 = PC^2 + AC^2$$

$$(12\text{m})^2 + (5\text{m})^2 = (AC)^2$$

$$AC^2 = (144+25) \text{ m}^2 = 169 \text{ m}^2$$

$$AC = 13\text{m}$$

Therefore, the distance between their tops is 13 m.

13. D and E are points on the sides CA and CB respectively of a triangle ABC right angled at C. Prove that $AE^2 + BD^2 = AB^2 + DE^2$.

Solution:

Given, D and E are points on the sides CA and CB respectively of a triangle ABC right angled at C.

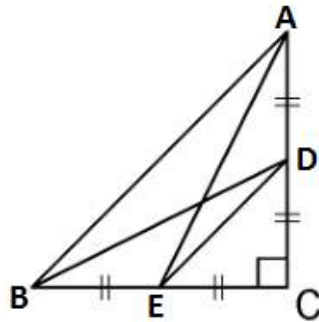

By Pythagoras theorem in ΔACE , we get

$$AC^2 + CE^2 = AE^2 \dots\dots\dots\text{(i)}$$

In ΔBCD , by Pythagoras theorem, we get

$$BC^2 + CD^2 = BD^2 \dots\dots\dots\text{(ii)}$$

From equations (i) and (ii), we get,

$$AC^2 + CE^2 + BC^2 + CD^2 = AE^2 + BD^2 \dots\dots\dots\text{(iii)}$$

In ΔCDE , by Pythagoras theorem, we get

$$DE^2 = CD^2 + CE^2$$

In ΔABC , by Pythagoras theorem, we get

$$AB^2 = AC^2 + CB^2$$

Putting the above two values in equation (iii), we get

$$DE^2 + AB^2 = AE^2 + BD^2.$$

14. The perpendicular from A on side BC of a ΔABC intersects BC at D such that $DB = 3CD$ (see Figure). Prove that $2AB^2 = 2AC^2 + BC^2$.

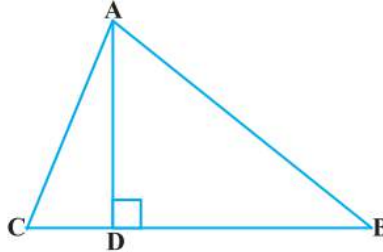

Solution:

Given, the perpendicular from A on side BC of a ΔABC intersects BC at D such that;
 $DB = 3CD$.

In ΔABC ,

$AD \perp BC$ and $BD = 3CD$

In right angle triangle, ADB and ADC, by Pythagoras theorem,

$$AB^2 = AD^2 + BD^2 \dots\dots\dots\text{(i)}$$

$$AC^2 = AD^2 + DC^2 \dots\dots\dots\text{(ii)}$$

Subtracting equation (ii) from equation (i), we get

$$AB^2 - AC^2 = BD^2 - DC^2$$

$$= 9CD^2 - CD^2 \text{ [Since, } BD = 3CD]$$

$$= 8CD^2$$

$$= 8(BC/4)^2 \text{ [Since, } BC = DB + CD = 3CD + CD = 4CD]$$

Therefore, $AB^2 - AC^2 = BC^2/2$

$$\Rightarrow 2(AB^2 - AC^2) = BC^2$$

$$\Rightarrow 2AB^2 - 2AC^2 = BC^2$$

$$\therefore 2AB^2 = 2AC^2 + BC^2.$$

15. In an equilateral triangle ABC, D is a point on side BC such that $BD = 1/3BC$. Prove that $9AD^2 = 7AB^2$.

Solution:

Given, ABC is an equilateral triangle.

And D is a point on side BC such that $BD = 1/3BC$

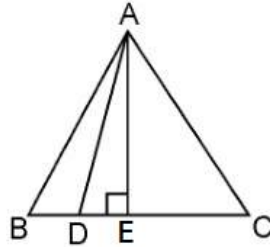

Let the side of the equilateral triangle be a , and AE be the altitude of $\triangle ABC$.

$$\therefore BE = EC = BC/2 = a/2$$

$$\text{And, } AE = a\sqrt{3}/2$$

$$\text{Given, } BD = 1/3BC$$

$$\therefore BD = a/3$$

$$DE = BE - BD = a/2 - a/3 = a/6$$

In $\triangle ADE$, by Pythagoras theorem,

$$AD^2 = AE^2 + DE^2$$

$$\begin{aligned} AD^2 &= \left(\frac{a\sqrt{3}}{2}\right)^2 + \left(\frac{a}{6}\right)^2 \\ &= \left(\frac{3a^2}{4}\right) + \left(\frac{a^2}{36}\right) \\ &= \frac{28a^2}{36} \\ &= \frac{7}{9}AB^2 \end{aligned}$$

$$\Rightarrow 9 AD^2 = 7 AB^2$$

16. In an equilateral triangle, prove that three times the square of one side is equal to four times the square of one of its altitudes.

Solution:

Given, an equilateral triangle say ABC ,

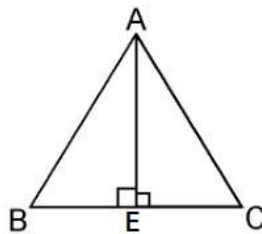

Let the sides of the equilateral triangle be of length a , and AE be the altitude of $\triangle ABC$.

$$\therefore BE = EC = BC/2 = a/2$$

In $\triangle ABE$, by Pythagoras Theorem, we get

$$AB^2 = AE^2 + BE^2$$

$$a^2 = AE^2 + \left(\frac{a}{2}\right)^2$$

$$AE^2 = a^2 - \frac{a^2}{4}$$

$$AE^2 = \frac{3a^2}{4}$$

$$4AE^2 = 3a^2$$

$$\Rightarrow 4 \times (\text{Square of altitude}) = 3 \times (\text{Square of one side})$$

Hence, proved.

17. Tick the correct answer and justify: In $\triangle ABC$, $AB = 6\sqrt{3}$ cm, $AC = 12$ cm and $BC = 6$ cm. The angle B is:

(A) 120°

(B) 60°

(C) 90°

(D) 45°

Solution:

Given, in $\triangle ABC$, $AB = 6\sqrt{3}$ cm, $AC = 12$ cm and $BC = 6$ cm.

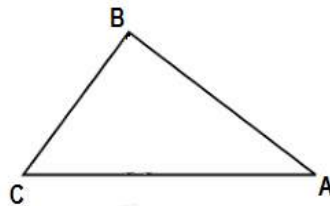

We can observe that,

$$AB^2 = 108$$

$$AC^2 = 144$$

$$\text{And, } BC^2 = 36$$

$$AB^2 + BC^2 = AC^2$$

The given triangle, $\triangle ABC$, is satisfying Pythagoras theorem.

Therefore, the triangle is a right triangle, right-angled at B.

$$\therefore \angle B = 90^\circ$$

Hence, the correct answer is (C).