

# GATE 2018

## Set-2

Mechanical Engineering

Questions



## SECTION: GENERAL APTITUDE

1. The perimeters of a circle, a square and an equilateral triangle are equal. Which one of the following statements is true?
  - A. The circle has the largest area.
  - B. The square has the largest area.
  - C. The equilateral triangle has the largest area.
  - D. All the three shapes have the same area.
  
2. The value of the expression  $\frac{1}{1 + \log_u vw} + \frac{1}{1 + \log_u wu} + \frac{1}{1 + \log_u uv}$  is \_\_\_\_\_ .
  - A. -1
  - B. 0
  - C. 1
  - D. 3
  
3. Find the missing group of letters in the following series:  
BC, FGH, LMNO, \_\_\_\_\_
  - A. UVWXY
  - B. TUVWX
  - C. STUVW
  - D. RSTUV
  
4. "The dress \_\_\_\_\_ her so well that they all immediately \_\_\_\_\_ her on her appearance."  
The words that best fill the blanks in the above sentence are
  - A. complemented, complemented
  - B. complimented, complemented
  - C. complimented, complimented
  - D. complemented, complimented
  
5. "The judge's standing in the legal community, though shaken by false allegations of wrongdoing, remained \_\_\_\_\_."  
The word that best fills the blank in the above sentence is
  - A. undiminished
  - B. damaged
  - C. illegal
  - D. uncertain
  
6. A house has a number which needs to be identified. The following three statements are given that can help in identifying the house number.
  - i. If the house number is a multiple of 3, then it is a number from 50 to 59.
  - ii. If the house number is NOT a multiple of 4, then it is a number from 60 to 69.
  - iii. If the house number is NOT a multiple of 6, then it is a number from 70 to 79.
 What is the house number?
  - A. 54
  - B. 65
  - C. 66
  - D. 76
  
7. Forty students watched films A, B and C over a week. Each student watched either only one film or all three. Thirteen students watched film A, sixteen students watched film B and nineteen students watched film C. How many students watched all three films?
  - A. 0
  - B. 2
  - C. 4
  - D. 8
  
8. An unbiased coin is tossed six times in a row and four different such trials are conducted. One trial implies six tosses of the coin. If H stands for head and T stands for tail, the following are the observations from the four trials:
  - (1) HTHTHT
  - (2) TTHHHT
  - (3) HTTHHT
  - (4) HHHT
 Which statement describing the last two coin tosses of the fourth trial has the highest probability of being correct?
  - A. Two T will occur.
  - B. One H and one T will occur.

C. Two H will occur.

D. One H will be followed by one T.

- 9.** A wire would enclose an area of  $1936 \text{ m}^2$ , if it is bent into a square. The wire is cut into two pieces. The longer piece is thrice as long as the shorter piece. The long and the short pieces are bent into a square and a circle, respectively. Which of the following choices is closest to the sum of the areas enclosed by the two pieces in square meters?

A. 1096

B. 1111

C. 1243

D. 2486

- 10.** A contract is to be completed in 52 days and 125 identical robots were employed, each operational for 7 hours a day. After 39 days, five-seventh of the work was completed. How many additional robots would be required to complete the work on time, if each robot is now operational for 8 hours a day?

A. 50

B. 89

C. 146

D. 175

**MECHANICAL ENGINEERING**

1. A frictionless gear train is shown in the figure. The leftmost 12-teeth gear is given a torque of 100 N-m. The output torque from the 60-teeth gear on the right in N-m is

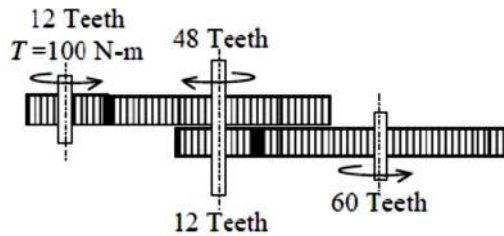

- A. 5                                      B. 20  
C. 500                                      D. 2000

2. For an ideal gas with constant properties undergoing a quasi-static process, which one of the following represents the change of entropy from state 1 to 2?

- A.  $\Delta s = C_p \ln\left(\frac{T_2}{T_1}\right) - R \ln\left(\frac{P_2}{P_1}\right)$   
B.  $\Delta s = C_v \ln\left(\frac{T_2}{T_1}\right) - C_p \ln\left(\frac{V_2}{V_1}\right)$   
C.  $\Delta s = C_p \ln\left(\frac{T_2}{T_1}\right) - C_v \ln\left(\frac{P_2}{P_1}\right)$   
D.  $\Delta s = C_v \ln\left(\frac{T_2}{T_1}\right) + R \ln\left(\frac{V_1}{V_2}\right)$

3. Select the correct statement for 50% reaction stage in a steam turbine.

- A. The rotor blade is symmetric.  
B. The stator blade is symmetric.

C. The absolute inlet flow angle is equal to absolute exit flow angle.

D. The absolute exit flow angle is equal to inlet angle of rotor blade.

4. In a single degree of freedom underdamped spring-mass-damper system as shown in the figure, an additional damper is added in parallel such that the system still remains underdamped. Which one of the following statements is ALWAYS true?

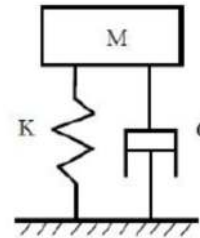

- A. Transmissibility will increase.  
B. Transmissibility will decrease.  
C. Time period of free oscillations will increase.  
D. Time period of free oscillations will decrease.

5. The divergence of the vector field  $\vec{u} = e^x (\cos y \hat{i} + \sin y \hat{j})$  is

- A. 0  
B.  $e^x \cos y + e^x \sin y$   
C.  $2e^x \cos y$   
D.  $2e^x \sin y$

6. Fatigue life of a material for a fully reversed loading condition is estimated from

$$\sigma_a = 1100 N^{-0.15},$$

Where,  $\sigma_a$  is the stress amplitude in MPa and  $N$  is the failure life in cycles. The maximum allowable stress amplitude (in MPa) for a life of  $1 \times 10^5$  cycles under the same loading condition is \_\_\_\_\_ (correct to two decimal places).

7. Denoting L as liquid and M as solid in a phase-diagram with the subscripts representing different phases, a eutectoid reaction is described by

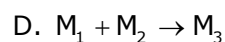
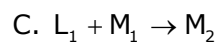
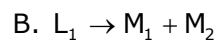
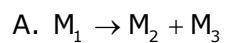

8. Metal removal in electric discharge machining takes place through

A. ion displacement

B. melting and vaporization

C. corrosive reaction

D. plastic shear

9. Match the following products with the suitable manufacturing process

| Product |                 | Manufacturing process |                     |
|---------|-----------------|-----------------------|---------------------|
| P       | Toothpaste tube | 1                     | Centrifugal casting |
| Q       | Metallic pipes  | 2                     | Blow moulding       |
| R       | Plastic bottles | 3                     | Rolling             |
| S       | Threaded bolts  | 4                     | Impact extrusion    |

A. P-4, Q-3, R-1, S-2

B. P-2, Q-1, R-3, S-4

C. P-4, Q-1, R-2, S-3

D. P-1, Q-3, R-4, S-2

10. Pre-tensioning of a bolted joint is used to

A. strain harden the bolt head

B. decrease stiffness of the bolted joint

C. increase stiffness of the bolted joint

D. prevent yielding of the thread root

11. The peak wavelength of radiation emitted by a black body at a temperature of 2000 K is 1.45  $\mu\text{m}$ . If the peak wavelength of emitted radiation changes to 2.90  $\mu\text{m}$ , then the temperature (in K) of the black body is

A. 500

B. 1000

C. 4000

D. 8000

12. A hollow circular shaft of inner radius 10 mm, outer radius 20 mm and length 1 m is to be used as a torsional spring. If the shear modulus

of the material of the shaft is 150 GPa, the torsional stiffness of the shaft (in kN-m/rad) is \_\_\_\_\_ (correct to two decimal places).

13. The Fourier cosine series for an even function is given by

$$f(x) = a_0 + \sum_{n=1}^{\infty} a_n \cos(nx).$$

The value of the coefficient  $a_2$  for the function  $f(x) = \cos^2(x)$  in  $[0, \pi]$  is

- A. -0.5                                      B. 0.0  
C. 0.5                                         D. 1.0

14. If  $y$  is the solution of the differential equation

$$y^3 \frac{dy}{dx} + x^3 = 0, y(0) = 1, \text{ the value of } y(-1) \text{ is}$$

- A. -2                                         B. -1  
C. 0    D. 1

15. If  $A = \begin{bmatrix} 1 & 2 & 3 \\ 0 & 4 & 5 \\ 0 & 0 & 1 \end{bmatrix}$  then  $\det(A^{-1})$  is \_\_\_\_\_

(correct to two decimal places).

16. Consider a function  $u$  which depends on position  $x$  and time  $t$ . The partial differential equation

$$\frac{\partial u}{\partial t} = \frac{\partial^2 u}{\partial x^2}$$

is known as the

- A. Wave equation  
B. Heat equation  
C. Laplace's equation  
D. Elasticity equation

17. The viscous laminar flow of air over a flat plate results in the formation of a boundary layer. The boundary layer thickness at the end of the plate of length  $L$  is  $\delta_L$ . When the plate length is increased to twice its original length, the percentage change in laminar boundary layer

thickness at the end of the plate (with respect to  $\delta_L$ ) is (correct to two decimal places).

18. Feed rate in slab milling operation is equal to  
A. rotation per minute (rpm)  
B. product of rpm and number of teeth in the cutter  
C. product of rpm, feed per tooth and number of teeth in the cutter  
D. product of rpm, feed per tooth and number of teeth in contact

19. The minimum axial compressive load,  $P$ , required to initiate buckling for a pinned-pinned slender column with bending stiffness  $EI$  and length  $L$  is

A.  $P = \frac{\pi^2 EI}{4L^2}$                                       B.  $P = \frac{\pi^2 EI}{L^2}$

C.  $P = \frac{3\pi^2 EI}{4L^2}$                                       D.  $P = \frac{4\pi^2 EI}{L^2}$

20. During solidification of a pure molten metal, the grains in the casting near the mould wall are  
A. coarse and randomly oriented  
B. fine and randomly oriented  
C. fine and ordered  
D. coarse and ordered

21. A ball is dropped from rest from a height of 1 m in a frictionless tube as shown in the figure. If the tube is approximated by two straight lines (ignoring the curved portion), the total distance travelled (in m) by the ball is \_\_\_\_\_ (correct to two decimal places).

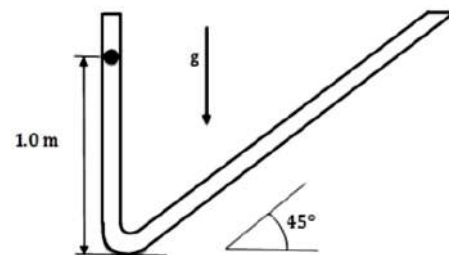

22. An engine operates on the reversible cycle as shown in the figure. The work output from the engine (in kJ/cycle) is \_\_\_\_\_ (correct to two decimal places).

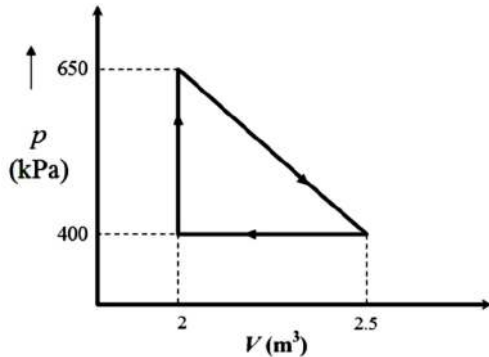

23. The preferred option for holding an odd-shaped workpiece in a centre lathe is
- live and dead centres
  - three jaw chuck
  - lathe dog
  - four jaw chuck
24. A local tyre distributor expects to sell approximately 9600 steel belted radial tyres next year. Annual carrying cost in Rs. 16 per tyre and ordering cost is Rs. 75. The economic order quantity of the tyres is
- 64
  - 212
  - 300
  - 1200
25. The arrival of customers over fixed time intervals in a bank follow a Poisson distribution with an average of 30 customers/hour. The probability that the time between successive customer arrivals is between 1 and 3 minutes is \_\_\_\_\_ (correct to two decimal places).
26. A bar is subjected to a combination of a steady load of 60 kN and a load fluctuating between -10 kN and 90 kN. The corrected endurance limit of the bar is 150 MPa, the yield strength of the material is 480 MPa and the ultimate strength of the material is 600 MPa. The bar cross-

section is square with side  $a$ . If the factor of safety is 2, the value of  $a$  (in mm), according to the modified Goodman's criterion, is \_\_\_\_\_ (correct to two decimal places).

27. A thin-walled cylindrical can with rigid end caps has a mean radius  $R = 100$  mm and a wall thickness of  $t = 5$  mm. The can is pressurized and an additional tensile stress of 50 MPa is imposed along the axial direction as shown in the figure. Assume that the state of stress in the wall is uniform along its length. If the magnitudes of axial and circumferential components of stress in the can are equal, the pressure (in MPa) inside the can is \_\_\_\_\_ (correct to two decimal places).

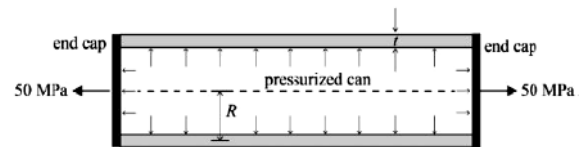

28. The true stress (in MPa) versus true strain relationship for a metal is given by

$$\sigma = 1020 \varepsilon^{0.4}$$

The cross-sectional area at the start of test (when the stress and strain values are equal to zero) is  $100 \text{ mm}^2$ . The cross-sectional area at the time of necking (in  $\text{mm}^2$ ) is \_\_\_\_\_ (correct to two decimal places).

29. Air is held inside a non-insulated cylinder using a piston (mass  $M=25$  kg and area  $A=100 \text{ cm}^2$ ) and stoppers (of negligible area), as shown in the figure. The initial pressure  $P_i$  and temperature  $T_i$  of air inside the cylinder are 200 kPa and  $400^\circ\text{C}$ , respectively. The ambient pressure  $P_\infty$  and temperature  $T_\infty$  are 100 kPa and  $27^\circ\text{C}$ , respectively. The temperature of the air inside the cylinder ( $^\circ\text{C}$ ) at which the piston

will begin to move is \_\_\_\_\_ (correct to two decimal places).

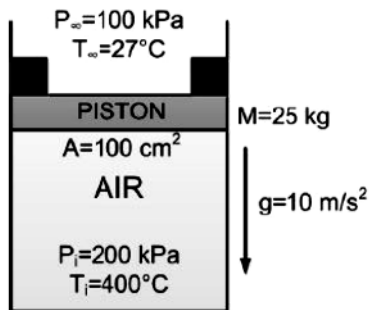

30. A force of 100 N is applied to the centre of a circular disc, of mass 10 kg and radius 1 m, resting on a floor as shown in the figure. If the disc rolls without slipping on the floor, the linear acceleration (in m/s<sup>2</sup>) of the centre of the disc is \_\_\_\_\_ (correct to two decimal places).

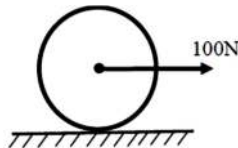

31. Steam in the condenser of a thermal power plant is to be condensed at a temperature of 30°C with cooling water which enters the tubes of the condenser at 14°C and exits at 22°C. Overall heat transfer coefficient is 2000 W/m<sup>2</sup>K and the total surface area of the tubes is 50 m<sup>2</sup>. Net heat transfer (in MW) is \_\_\_\_\_ (correct to two decimal places).

32. A steel wire is drawn from an initial diameter ( $d_i$ ) of 10 mm to a final diameter ( $d_f$ ) of 7.5 mm. The half cone angle ( $\alpha$ ) of the die is 5° and the coefficient of friction ( $\mu$ ) between the die and the wire is 0.1. The average of the initial and final yield stress  $[(\sigma_Y)_{avg}]$  is 350 MPa. The equation for drawing stress  $\sigma_f$ , (in MPa) is given as:

$$\sigma_f = (\sigma_Y)_{avg} \left\{ 1 + \frac{1}{\mu \cot \alpha} \right\} \left[ 1 - \left( \frac{d_f}{d_i} \right)^{2\mu \cot \alpha} \right]$$

The drawing stress (in MPa) required to carry out this operation is \_\_\_\_\_ (correct to two decimal places).

33. A bimetallic cylindrical bar of cross sectional area 1 m<sup>2</sup> is made by bonding Steel (Young's modulus = 210 GPa) and Aluminium (Young's modulus = 70 GPa) as shown in the figure. To maintain tensile axial strain of magnitude 10<sup>-6</sup> in Steel bar and compressive axial strain of magnitude 10<sup>-6</sup> in Aluminium bar, the magnitude of the required force P (in kN.) along the indicated direction is

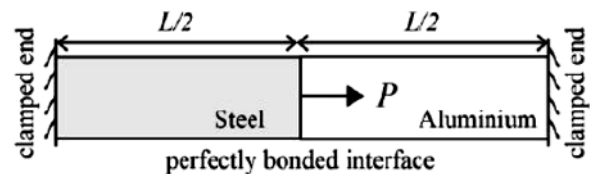

- A. 70  
B. 140  
C. 210  
D. 280
34. Let  $z$  be a complex variable. For a counter-clockwise integration around a unit circle  $C$ , centred at origin,

$$\oint_C \frac{1}{5z - 4} dz = A\pi i$$

the value of  $A$  is

- A. 2/5  
B. 1/2  
C. 2  
D. 4/5
35. In a rigid body in plane motion, the point R is accelerating with respect to point P at 10∠180° m/s<sup>2</sup>. If the instantaneous acceleration of point Q is zero, the acceleration (in m/s<sup>2</sup>) of point R is



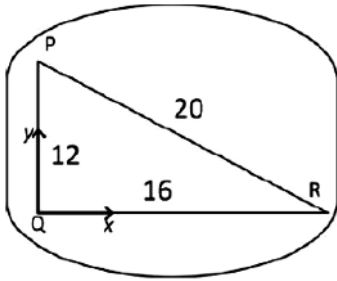

- A.  $8\angle 233^\circ$                       B.  $10\angle 225^\circ$   
 C.  $10\angle 217^\circ$                       D.  $8\angle 217^\circ$

36. Given the ordinary differential equation

$$\frac{d^2y}{dx^2} + \frac{dy}{dx} - 6y = 0$$

with  $y(0) = 0$  and  $\frac{dy}{dx}(0) = 1$ , the value of  $y(1)$  is \_\_\_\_\_ (correct to two decimal places).

37. A circular hole of 25 mm diameter and depth of 20 mm is machined by EDM process. The material removal rate (in  $\text{mm}^3/\text{min}$ ) is expressed as  $4 \times 10^4 IT^{-1.23}$ ,

where  $I = 300$  A and the melting point of the material  $T = 1600^\circ\text{C}$ . The time (in minutes) for machining this hole is \_\_\_\_\_ (correct to two decimal places).

38. In a cam-follower, the follower rises by  $h$  as the cam rotates by  $\delta$  (radians) at constant angular velocity  $\omega$  (radians/s). The follower is uniformly accelerating during the first half of the rise period and it is uniformly decelerating in the latter half of the rise period. Assuming that the magnitudes of the acceleration and deceleration are same, the maximum velocity of the follower is

- A.  $\frac{4h\omega}{\delta}$                                       B.  $h\omega$   
 C.  $\frac{2h\omega}{\delta}$                                       D.  $2h\omega$

39. Let  $X_1$  and  $X_2$  be two independent exponentially distributed random variables with means 0.5 and 0.25, respectively. Then  $Y = \min(X_1, X_2)$  is

- A. exponentially distributed with mean 1/6  
 B. exponentially distributed with mean 2  
 C. normally distributed with mean 3/4  
 D. normally distributed with mean 1/6

40. A bar of circular cross section is clamped at ends P and Q as shown in the figure. A torsional moment  $T = 150$  Nm is applied at a distance of 100 mm from end P. The torsional reactions ( $T_P, T_Q$ ) in Nm at the ends P and Q respectively are

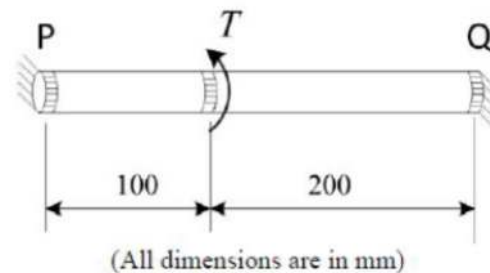

- A. (50,100)                                  B. (75,75)  
 C. (100,50)                                  D. (120,30)

41. Air flows at the rate of  $1.5 \text{ m}^3/\text{s}$  through a horizontal pipe with a gradually reducing cross-section as shown in the figure. The two cross-sections of the pipe have diameters of 400 mm and 200 mm. Take the air density as  $1.2 \text{ kg}/\text{m}^3$  and assume inviscid incompressible flow. The change in pressure ( $p_2 - p_1$ ) (in kPa) between sections 1 and 2 is

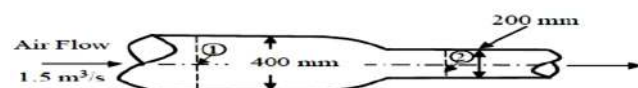

- A. -1.28                                      B. 2.56  
 C. -2.13                                      D. 1.28

42. The problem of maximizing  $z = x_1 - x_2$  subject to constraints  $x_1 + x_2 \leq 10, x_1 \geq 0, x_2 \geq 0$  and  $x_2 \leq 5$  has
- no solution
  - one solution
  - two solution
  - more than two solutions

43. A standard vapor compression refrigeration cycle operating with a condensing temperature of  $35^\circ\text{C}$  and an evaporating temperature of  $-10^\circ\text{C}$  develops 15 kW of cooling. The p-h diagram shows the enthalpies at various states. If the isentropic efficiency of the compressor is 0.75, the magnitude of compressor power (in kW) is \_\_\_\_\_ (correct to two decimal places).

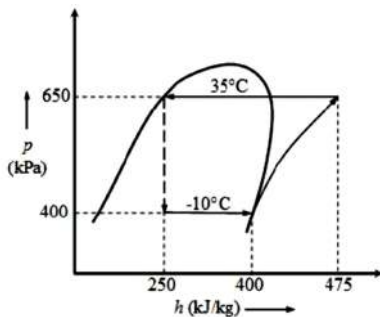

44. A 0.2 m thick infinite black plate having a thermal conductivity of  $3.96 \text{ W/m}\cdot\text{K}$  is exposed to two infinite black surfaces at 300 K and 400 K as shown in the figure. At steady state, the surface temperature of the plate facing the cold side is 350 K. The value of Stefan-Boltzmann constant,  $\sigma$ , is  $5.67 \times 10^{-8} \text{ W/m}^2 \text{ K}^4$ . Assuming 1-D heat conduction, the magnitude of heat flux through the plate (in  $\text{W/m}^2$ ) is \_\_\_\_\_ (correct to two decimal places).

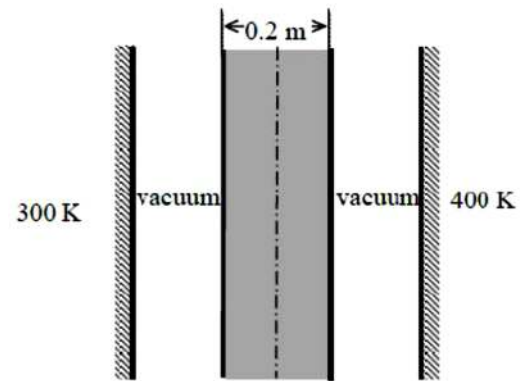

45. Following data correspond to an orthogonal turning of a 100 mm diameter rod on a lathe. Rake angle:  $+15^\circ$ ; Uncut chip thickness: 0.5 mm; nominal chip thickness after the cut: 1.25 mm. The shear angle (in degrees) for this process is \_\_\_\_\_ (correct to two decimal places).
46. Taylor's tool life equation is used to estimate the life of a batch of identical HSS twist drills by drilling through holes at constant feed in 20 mm thick mild steel plates. In test 1, a drill lasted 300 holes at 150 rpm while in test 2, another drill lasted 200 holes at 300 rpm. The maximum number of holes that can be made by another drill from the above batch at 200 rpm is \_\_\_\_\_ (correct to two decimal places).
47. A rigid rod of length 1 m is resting at an angle  $\theta = 45^\circ$  as shown in the figure. The end P is dragged with a velocity of  $U = 5 \text{ m/s}$  to the right. At the instant shown, the magnitude of the velocity  $V$  (in  $\text{m/s}$ ) of point Q as it moves along the wall without losing contact is \_\_\_\_\_

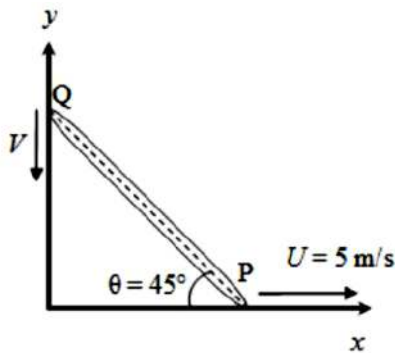

- A. 5                                      B. 6  
C. 8                                      D. 10

48. A frictionless circular piston of area  $10^{-2} \text{ m}^2$  and mass 100 kg sinks into a cylindrical container of the same area filled with water of density  $1000 \text{ kg/m}^3$  as shown in the figure. The container has a hole of area  $10^{-3} \text{ m}^2$  at the bottom that is open to the atmosphere. Assuming there is no leakage from the edges of the piston and considering water to be incompressible, the magnitude of the piston velocity (in m/s) at the instant shown is \_\_\_\_\_ (correct to two decimal places).

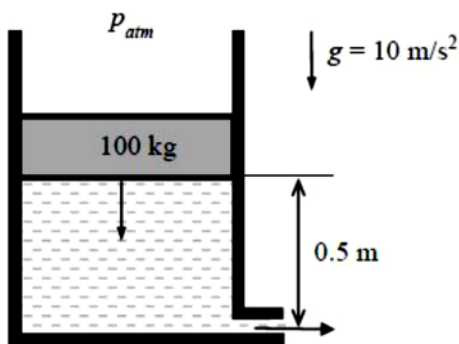

49. A test is conducted on a one-fifth scale model of a Francis turbine under a head of 2 m and volumetric flow rate of  $1 \text{ m}^3/\text{s}$  at 450 rpm. Take the water density and the acceleration due to gravity as  $10^3 \text{ kg/m}^3$  and  $10 \text{ m/s}^2$ , respectively. Assume no losses both in model and prototype turbines. The power (in MW) of a full sized turbine while working under a head

of 30 m is \_\_\_\_\_ (correct to two decimal places).

50. A welding operation is being performed with voltage = 30 V and current = 100 A. The cross-sectional area of the weld bead is  $20 \text{ mm}^2$ . The work-piece and filler are of titanium for which the specific energy of melting is  $14 \text{ J/mm}^3$ . Assuming a thermal efficiency of the welding process 70%, the welding speed (in mm/s) is \_\_\_\_\_ (correct to two decimal places).

51. The arc lengths of a directed graph of a project are as shown in the figure. The shortest path length from node 1 to node 6 is \_\_\_\_\_.

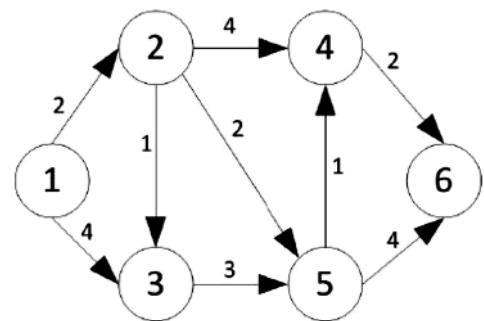

52. Ambient air is at a pressure of 100 kPa, dry bulb temperature of  $30^\circ\text{C}$  and 60% relative humidity. The saturation pressure of water at  $30^\circ\text{C}$  is 4.24 kPa. The specific humidity of air (in g/kg of dry air) is \_\_\_\_\_ (correct to two decimal places).

53. For a position vector  $\vec{r} = x\hat{i} + y\hat{j} + z\hat{k}$  the norm of the vector can be defined as  $|\vec{r}| = \sqrt{x^2 + y^2 + z^2}$ . Given a function  $\phi = \ln|\vec{r}|$ , its gradient  $\nabla\phi$  is

- A.  $\vec{r}$                                       B.  $\frac{\vec{r}}{|\vec{r}|}$   
C.  $\frac{\vec{r}}{\vec{r} \cdot \vec{r}}$                                       D.  $\frac{\vec{r}}{|\vec{r}|^3}$

- 54.** A vehicle powered by a spark ignition engine follows air standard Otto cycle ( $\gamma = 1.4$ ). The engine generates 70 kW while consuming 10.3 kg/hr of fuel. The calorific value of fuel is 44,000 kJ/kg. The compression ratio is \_\_\_\_\_ (correct to two decimal places).
- 55.** For sand-casting a steel rectangular plate with dimensions 80 mm  $\times$  120 mm  $\times$  20 mm, a

cylindrical riser has to be designed. The height of the riser is equal to its diameter. The total solidification time for the casting is 2 minutes. In Chvorinov's law for the estimation of the total solidification time, exponent is to be taken as 2. For a solidification time of 3 minutes in the riser, the diameter (in mm) of the riser is \_\_\_\_\_ (correct to two decimal places).

\*\*\*\*

## Benefits of Online Classroom Program

### 1. GATE Learning Tablet

- › Access high-quality classes at your convenience, anywhere and anytime with the tablet

### 2. Live Classroom Sessions

- › Get Access to Live Classes By India's Leading GATE Faculty

### 3. Previous Year Question Books

- › 20+ Years PYQs with Solutions

### 4. Workbooks

- › Access to 3000+ Practice Questions with solutions

### 5. Regular Quizzes

- › Sample Quizzes for daily practice and regular tests along with live class

### 6. Doubt Resolution

- › Complete Doubt Resolution within 24 hours by Subject Experts

## Additional Offerings

- › **Test Series** - Mock Tests based on GATE Exam pattern
- › **Preparation Guidance** - Get a competitive advantage from our Experts
- › **Subject wise formula Notes** - Comprehensive short notes for Revision
- › **Report Card** - Regular performance analysis along with Live Class

