

GATE 2021

Electronics
& Communication
Engineering

Questions
& Solutions

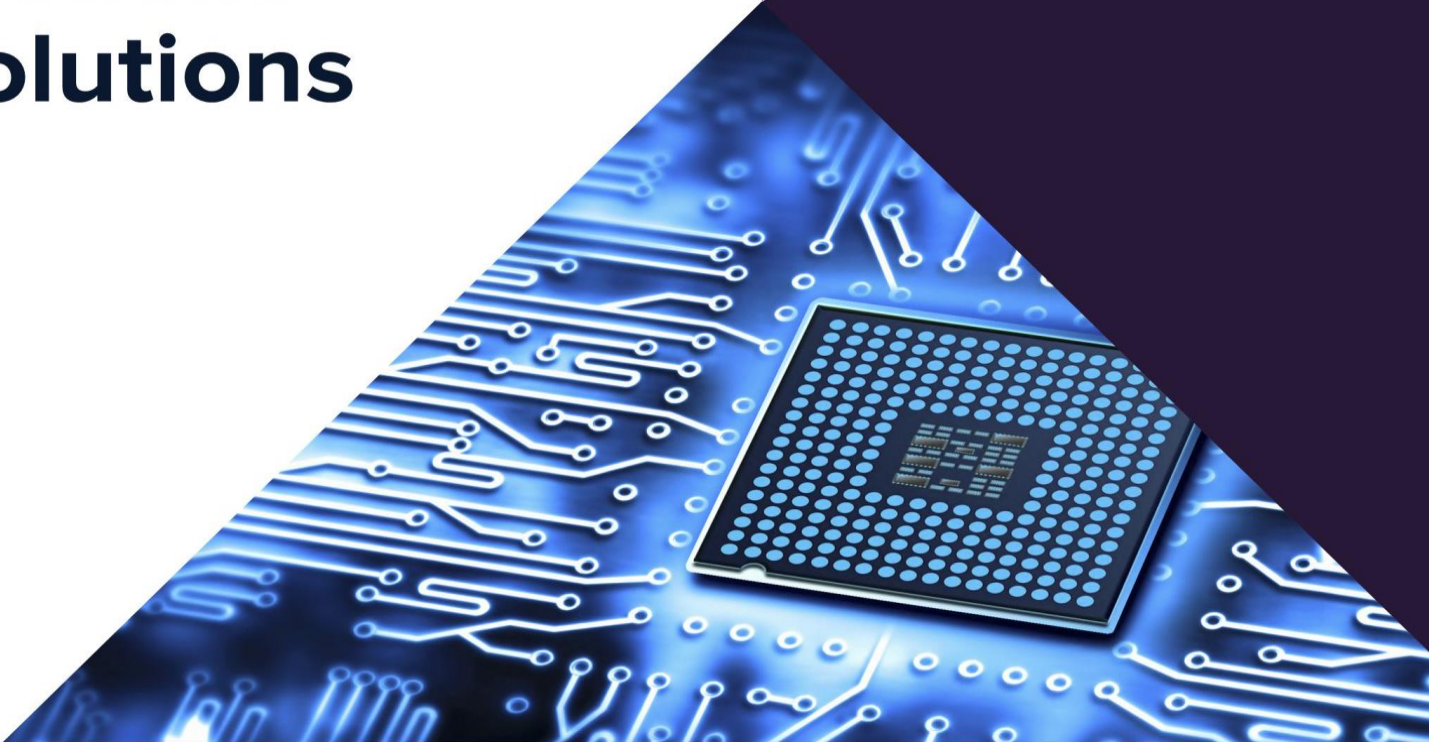

SECTION: GENERAL APTITUDE

1.

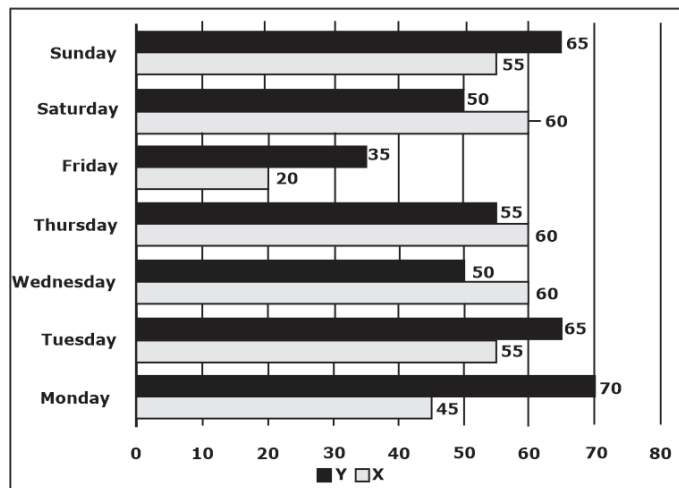

The number of minutes spent by two students, X and Y, exercising every day in a given week are shown in the bar chart above.

The number of days in the given week in which one of the students spent a minimum of 10% more than the other student, on a given day, is

- A. 5 B. 4
C. 7 D. 6

Ans. D

Sol. Sunday $\Rightarrow 55 + 10\% = 60.5$

$$65 > 60.5$$

$$\text{Monday} \Rightarrow 45 + 5.5\% = 49.5$$

$$70 > 49.5$$

$$\text{Tuesday} \Rightarrow 55 + 10\% = 60.5$$

$$65 > 60.5$$

$$\text{Wednesday} \Rightarrow 50 + 10\% = 55$$

$$60 > 55$$

$$\text{Thursday} \Rightarrow 55 + 10\% = 60.5$$

$$60 < 60.5$$

$$\text{Friday} \Rightarrow 20 + 10\% = 22$$

$$35 > 22$$

$$\text{Saturday} \Rightarrow 50 + 10\% = 55$$

$$60 > 55$$

2. p and q are positive integers and $\frac{p}{q} + \frac{q}{p} = 3$,

then $\frac{p^2}{q^2} + \frac{q^2}{p^2} =$

- A. 3 B. 11
C. 9 D. 7

Ans. D

Sol. $\left(\frac{p}{q} + \frac{q}{p}\right)^2 = \frac{p^2}{q^2} + \frac{q^2}{p^2} + 2$

$$\frac{p^2}{q^2} + \frac{q^2}{p^2} = 3^2 - 2 = 7$$

3. Computers are ubiquitous. They are used to improve efficiency in almost all fields from agriculture to space exploration. Artificial intelligence (AI) is currently a hot topic. AI enables computers to learn, given enough training data. For humans sitting in front of a computer for long hours can lead to health issues.

Which of the following can be deduced from the above passage?

(i) Nowadays, computers are present in almost all places.

(ii) Computers cannot be used for solving problems in engineering.

(iii) For humans, there are both positive and negative effects of using computers.

(iv) Artificial intelligence can be done without data.

- A. (i) and (iii) B. (ii) and (iii)
C. (i), (iii) and (iv) D. (ii) and (iv)

Ans. A

Sol. Nowadays, computers are present in almost all places. "efficiency in almost all fields from agriculture to space exploration" is true.

Computers cannot be used for solving problems in engineering. This statement is false. This is contradictory to the given passage. "from agriculture to space exploration"

For humans, there are both positive and negative effects of using computers. This statement is true. "can lead to health issues" shows the negative effect and positive effect is shown by "improve efficiency in almost all fields".

Artificial intelligence can be done without data. This statement is false. This is contradictory to the given passage. "given enough training data".

So, correct option is A.

4. The current population of a city is 11,02,500. If it has been increasing at the rate of 5% per annum, what was its population 2 years ago?
1. 10,00,000
 2. 9,92,500
 3. 12,51,506
 4. 9,95,006

Ans. A

Sol. Let current population = P

$$P(1.05)^2 = 1102500$$

$$P = 1000000$$

5. Nostalgia is to anticipation as _____ is to _____
Which one of the following maintains a similar logical relation in the above sentence?
- A. Future, past
 - B. Present, past
 - C. Past, future
 - D. Future, present

Ans. C

6. Consider the following sentences:

- (i) I woke up from sleep.
- (ii) I woked up from sleep.
- (iii) I was woken up from sleep.
- (iv) I was wokened up from sleep.

Which of the above sentences are grammatically CORRECT?

- A. (i) and (ii)
- B. (i) and (iii)
- C. (ii) and (iii)
- D. (i) and (iv)

Ans. B

Sol. Wake means to stop sleeping; to make somebody stop sleeping.

The three forms of the verb "wake":

- Present – Wake
- Past – Woke
- Past participle – Woken/Waked

The sentence (i) I woke up from sleep and sentence (iii) I was woken up from sleep is correct.

Hence, option (i) and (iii) is correct.

7.

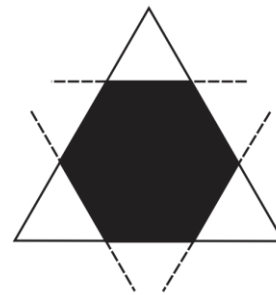

Corners are cut from an equilateral triangle to produce a regular convex hexagon as shown in the figure above.

The ratio of the area of the regular convex hexagon to the area of the original equilateral triangle is

- A. 3 : 4
- B. 2 : 3
- C. 4 : 5
- D. 5 : 6

Ans. B

Sol.

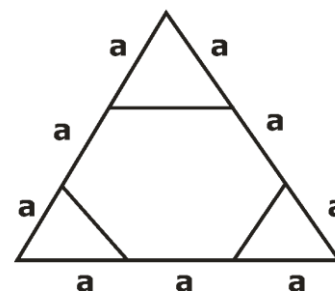

$$\frac{\text{area of hexagon}}{\text{area of triangle}} = \frac{69 \frac{\sqrt{3}}{4} a^2}{\frac{\sqrt{3}}{4} (3a)^2} = \frac{6}{9} = \frac{2}{3}$$

8. Consider a square sheet of side 1 unit. In the first step, it is cut along the main diagonal to get two triangles, In the next step, one of the triangles is revolved about its short edge to form a solid cone. The volume of the resulting cone, in cubic units, is _____

- A. 3π
- B. $\frac{3\pi}{2}$
- C. $\frac{\pi}{3}$
- D. $\frac{2\pi}{3}$

Ans. C

Sol.

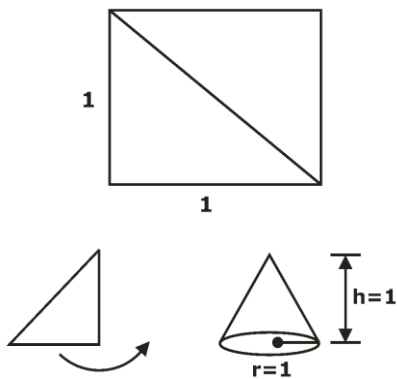

$$V = \frac{1}{3} \pi r^2 h = \frac{1}{3} \pi$$

9. Given below are two statements and two conclusions.

Statement 1: All purple are green.

Statement 2: All black are green.

Conclusion I: Some black are purple.

Conclusion II: No black is purple.

Based on the above statements and conclusions, which one of the following is logically CORRECT?

- A. Both conclusion I and II are correct.
- B. Either conclusion I or II is correct.
- C. Only conclusion II is correct.
- D. Only conclusion I is correct.

Ans. B

Sol.

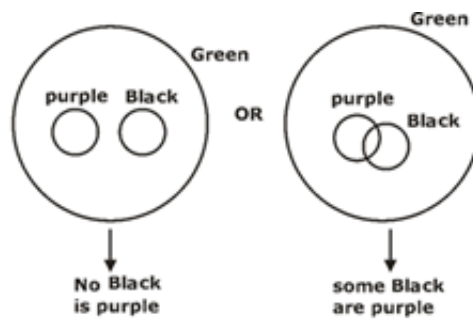

10.

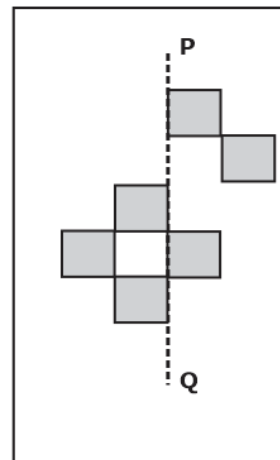

The least number of squares that must be added so that the line P-Q becomes the line of symmetry is _____

- A. 4
- B. 3
- C. 6
- D. 7

Ans. C

Sol.

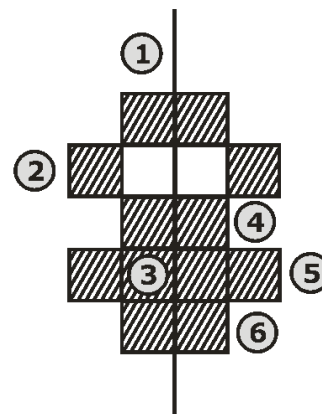

TECHNICAL

1. For the circuit with an ideal OPAMP shown in the figure, V_{REF} is fixed.

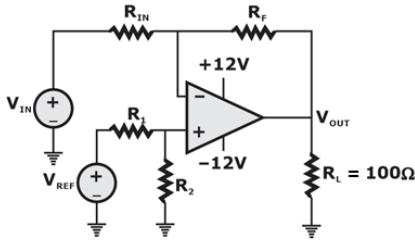

If $V_{OUT} = 1$ volt for $V_{IN} = 0.1$ volt and $V_{OUT} = 6$ volt for $V_{IN} = 1$ volt, where V_{OUT} is measured across R_L connected at the output of this OPAMP, the value of R_f/R_{IN} is

- A. 2.860 B. 3.825
C. 3.285 D. 5.555

Ans. D

Sol.
$$V_{out} = \left[1 + \frac{R_f}{R_{in}} \right] \cdot \left[1 + \frac{R_2}{R_1 + R_2} \right] V_{ref} - \frac{R_f}{R_{in}} V_{in}$$

Let $C = \left[1 + \frac{R_f}{R_{in}} \right] \cdot \left[1 + \frac{R_2}{R_1 + R_2} \right] V_{ref}$

$$V_{out 1} = C - \frac{R_f}{R_{in}} (0.1) = -1$$

$$V_{out 2} = C - \frac{R_f}{R_{in}} (1) = -6$$

$$\frac{R_f}{R_{in}} = \frac{5}{0.9} = 5.555 \text{ k}\Omega$$

2. An asymmetrical periodic pulse train v_{in} of 10 V amplitude with on-time $T_{ON} = 1$ ms and off-time $T_{OFF} = 1 \mu s$ is applied to the circuit shown in the figure. The diode D_1 is ideal.

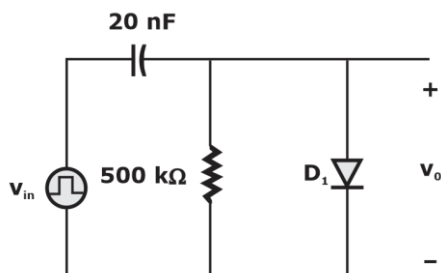

The difference between the maximum voltage and minimum voltage of the output waveform v_o (in integer) is ____ V.

Ans. 10

Sol. It is a negative clamper. The swing of the output = Swing of the input

$$\therefore V_{o \text{ Maximum}} - V_{o \text{ Minimum}} = 10V$$

3. The switch in the circuit in the figure is in position P for a long time and moved to position Q at time $t = 0$

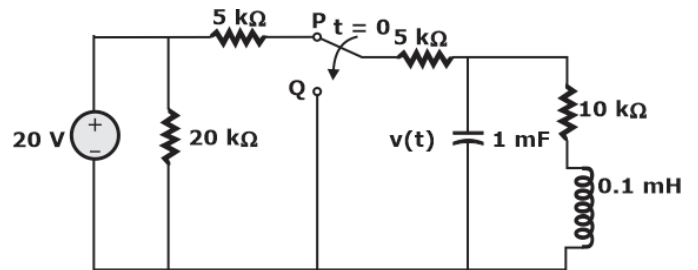

The value of $\frac{dv(t)}{dt}$ at $t = 0^+$ is

- A. -5 V/s B. 3 V/s
C. -3 V/s D. 0 V/s

Ans. C

Sol. At $t = 0^-$

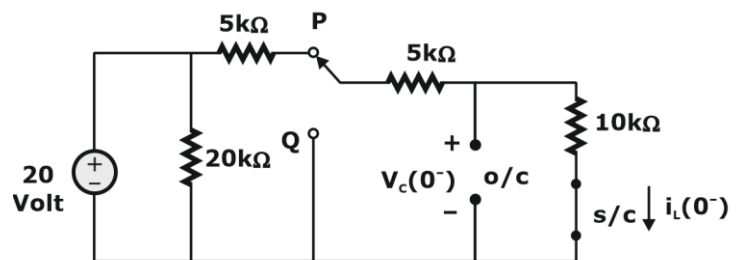

$$i_L(0^-) = \frac{20}{20} = 1\text{mA}$$

$$V_c(0^-) = 20 \times \frac{10}{20} = 10 \text{ volt}$$

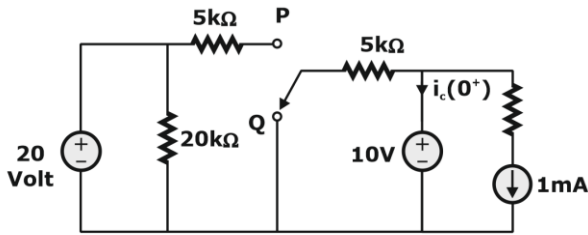

$$i_c(0^+) + \frac{10}{5} + 1 = 0$$

$$\Rightarrow i_c(0^+) = -3\text{mA}$$

$$\frac{dV_c(0^+)}{dt} = \frac{i_c(0^+)}{C} = \frac{-3\text{mA}}{1\text{mF}} = -3\text{volt/sec}$$

4. The energy band diagram of a p-type semiconductor bar of length L under equilibrium condition (i.e., the Fermi energy level E_F is constant) is shown in the figure. The valence band E_V is sloped since doping is non-uniform along the bar. The difference between the energy levels of the valence at the two edges of the bar is Δ .

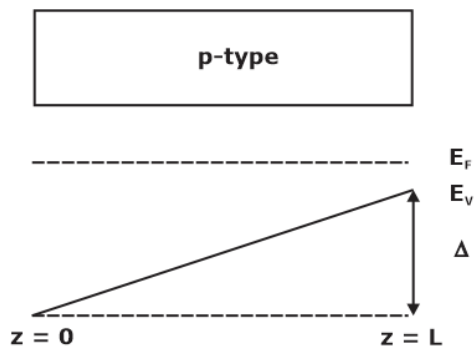

If the changes of an electron is q , then the magnitude of the electric field developed inside this semiconductor bar is

- A. $\frac{2\Delta}{qL}$ B. $\frac{3\Delta}{2qL}$
 C. $\frac{\Delta}{2qL}$ D. $\frac{\Delta}{qL}$

Ans. D

Sol. Electric field = $\frac{1}{q} \times \frac{dE}{dx}$

$$\frac{dE}{dx} = \frac{\Delta}{L}$$

$$\therefore E = \frac{\Delta}{qL}$$

5. The refractive indices of the core and cladding of an optical fiber are 1.50 and 1.48, respectively. The critical propagation angle, which is defined as the maximum angle that the light beam makes with the axis of the optical fiber to achieve the total internal reflection. (rounded off to two decimal places) is ____ degree.

Ans. 9.36

Sol.

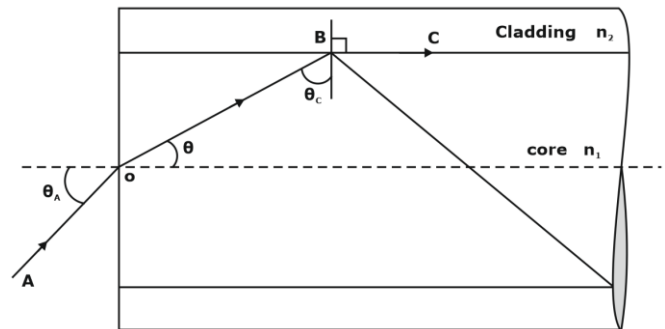

$$\theta_c = \text{Critical Angle} = \sin^{-1}\left(\frac{n_2}{n_1}\right)$$

$$\theta_a = \text{Acceptance Angle} = \sin^{-1}\left(\sqrt{n_1^2 - n_2^2}\right)$$

$$\theta = \text{Critical Propagation Angle} = 90 - \theta_c$$

$$\text{So, } \theta = 90 - \sin^{-1}\left(\frac{n_2}{n_1}\right)$$

$$= 90 - \sin^{-1}\left(\frac{1.48}{1.50}\right)$$

$$= 9.36^\circ$$

6. Consider the two-port network shown in the figure.

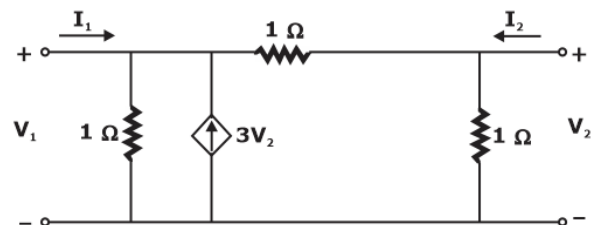

The admittance parameters, in Siemens, are

- A. $y_{11} = 2, y_{12} = -4, y_{21} = -4, y_{22} = 2$
- B. $y_{11} = 2, y_{12} = -4, y_{21} = -1, y_{22} = 2$
- C. $y_{11} = 2, y_{12} = -4, y_{21} = -4, y_{22} = 3$
- D. $y_{11} = 1, y_{12} = -2, y_{21} = -1, y_{22} = 3$

Ans. D

Sol. KCL at port 1,

$$I_1 = \frac{V_1}{1} - 3V_2 + \frac{V_1 - V_2}{1}$$

$$I_1 = 2V_1 - 4V_2 \quad \dots$$

(1)

KCL at port 2,

$$I_2 = V_2 + \frac{V_2 - V_1}{1}$$

$$I_2 = -V_1 + 2V_2 \quad \dots (2)$$

$$Y = \begin{bmatrix} 2 & -4 \\ -1 & 2 \end{bmatrix}$$

7. A unity feedback system that uses proportional-integral (PI) control is shown in the figure.

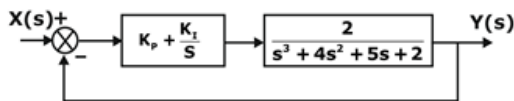

The stability of the overall system is controlled by tuning the PI control parameters K_P and K_I . The maximum value of K_I that can be chosen so as to keep the overall system stable or, in the worst case, marginally stable (rounded off to three decimal places) is _____

Ans. 3.125

Sol. CE: $1 + \frac{sk_p + K_I}{s} \times \frac{2}{s^3 + 4s^2 + 5s + 2}$

$$s^4 + 4s^3 + 5s^2 + (2 + 2k_p)s + 2K_I = 0$$

Routh Array

s^4	1	5	$2K_I$
s^3	4	$2 + 2K_P$	0
s^2	$\frac{18 - 2K_P}{4}$	$2K_I$	0

$$s^1 \quad \frac{\left(\frac{18 - 2k_p}{4}\right)(2 + 2K_p) - 8K_I}{\frac{18 - 2k_p}{4}} \quad 0 \quad 0$$

$$s^0 \quad 2K_I \quad 0 \quad 0$$

For marginally stable

$$1. \quad \frac{18 - 2K_P}{4} > 0 \rightarrow K_P < 9$$

$$2. \quad 2K_I > 0 \rightarrow K_I > 0$$

$$3. \quad \left(\frac{18 - 2K_P}{4}\right)(2 + 2K_P) - 8K_I = 0 \Rightarrow \text{Roz}$$

$$(9 - K_P)(1 + K_P) - 8K_I = 0$$

$$\Rightarrow 8y = 9 + 8x - x^2$$

$$\frac{8dy}{dx} = 8 - 2x = 0$$

So, K_I is maximum for $K_P = 4$

$$8(K_I)_{\max} = 9 + 8(4) - 4^2$$

$$= 9 + 32 - 16 = 25$$

$$(K_I)_{\max} = \frac{25}{8} = 3.125$$

8. A silicon P-N junction is shown in the figure.

The doping in the P region is $5 \times 10^{16} \text{ cm}^{-3}$ and doping in the N region is $10 \times 10^{16} \text{ cm}^{-3}$. The parameters given are

Built-in voltage (Φ_{bi}) = 0.8 V

Electron charge (q) = $1.6 \times 10^{-19} \text{ C}$

Vacuum permittivity (ϵ_0) = $8.85 \times 10^{-12} \text{ F/m}$

Relative permittivity of silicon (ϵ_{si}) = 12

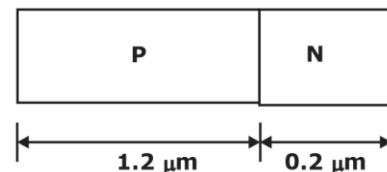

The magnitude of reverse bias voltage that would completely deplete one of the two regions (P or N) prior to the other (rounded off to one decimal place) is _____ V.

Ans. 8.24

Sol.

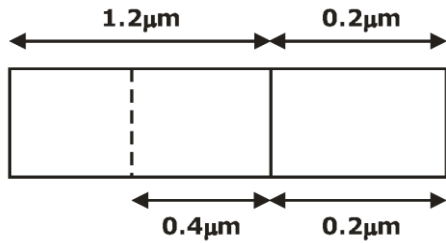

$$N_A w_p = N_D w_n$$

$$5 \times 10^{16} w_p = 10 \times 10^{16} w_n$$

$$\text{If } w_n = 0.2 \mu\text{m} \therefore w_p = 0.4 \mu\text{m}$$

$$\therefore w = w_n + w_p = 0.6 \mu\text{m} = 0.6 \times 10^{-4} \text{ cm} \quad (1)$$

w = total depletion width

$$V_j = V_0 + V_R = \frac{qN}{2\epsilon_s} \cdot w^2 \quad (2)$$

V_0 = built in potential

V_R = applied voltage in reverse biased

$$\frac{1}{N} = \frac{1}{N_A} + \frac{1}{N_D} = \frac{1}{5 \times 10^{16}} + \frac{1}{10 \times 10^{16}}$$

$$\therefore N = 10/3 \times 10^{16} \text{ (cm}^{-3}\text{)} \quad (3)$$

$$\epsilon_s = 12 \times 8.85 \times 10^{-12} \text{ F/m}$$

$$\epsilon_s = 106.2 \times 10^{-14} \text{ F/cm} \quad (4)$$

$$\phi_{bi} = V_0 = 0.8 \text{ V} \quad (5)$$

putting equation (1), (3), (4), (5) in equation (2)

$$0.8 + V_R = \frac{1.6 \times 10^{-19} \times 10/3 \times 10^{16}}{2 \times 106.2 \times 10^{-14}} \times (0.6 \times 10^{-4})^2$$

$$0.8 + V_R = 9.039$$

$$V_R = 9.039 - 0.8$$

$$V_R = 8.239 \cong 8.24 \text{ V}$$

9. If $(1235)_x = (3033)_y$, where x and y indicate the bases of the corresponding numbers, then

A. $x = 8$ and $y = 6$ B. $x = 7$ and $y = 5$

C. $x = 9$ and $y = 7$ D. $x = 6$ and $y = 4$

Ans. A

Sol. $(1235)_x = (3033)_y$

$$X^3 + 2X^2 + X^1 \times 3 + X^0 \times 5 = Y^3 \times 3 + Y^2 \times 0$$

$$+ Y^1 \times 3 + Y^0 \times 3$$

x must be > 5

y must be > 4

$$8^3 + 8^2 \times 2 + 8^1 \times 3 + 1^0 \times 5 = 6^3 \times 3 + 6^2$$

$$\times 0 + 6 \times 3 + 1 \times 3$$

$$512 + 128 + 24 + 5 = 648 + 18 + 3$$

$$669 = 669$$

Hence $x = 8$, $y = 6$

10. Two continuous random variables X and Y are related as

$$Y = 2X + 3$$

Let σ_X^2 and σ_Y^2 denotes the variances of X and Y respectively. The variances are related as

A. $\sigma_Y^2 = 4 \sigma_X^2$

B. $\sigma_Y^2 = 25 \sigma_X^2$

C. $\sigma_Y^2 = 2 \sigma_X^2$

D. $\sigma_Y^2 = 5 \sigma_X^2$

Ans. A

Sol. Variance of x is σ_x^2

Variance of y is _____ if $Y = 2x + 3$

$$\sigma_y^2 = 4\sigma_x^2$$

11. Consider a real-valued base-band signal $x(t)$, band limited to 10 kHz. The Nyquist rate for

the signal $y(t) = x(t) \times \left(1 + \frac{t}{2}\right)$ is

A. 60 kHz

B. 20 kHz

C. 15 kHz

D. 30 kHz

Ans. D

Sol. $x(t)$ is band limited signal to 10kHz.

$$y(t) = x(t) \times \left(\frac{t}{2} + 1\right)$$

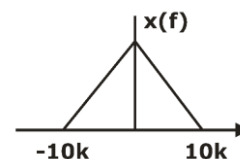

$$Y(f) = X(f) \times 2x(2f)$$

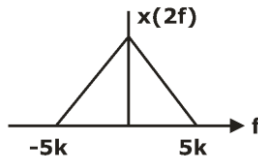

$$f_m = 15 \text{ kHz}$$

$$NR = 30 \text{ kHz}$$

12. A circuit with an ideal OPAMP is shown in the figure. A pulse V_{IN} of 20 ms duration is applied to the input. The capacitors are initially uncharged.

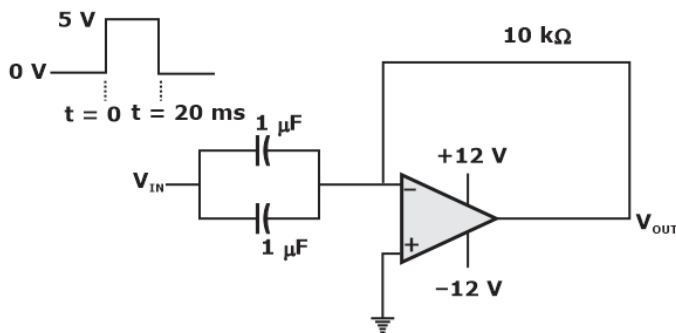

The output voltage V_{OUT} of this circuit at $t = 0^+$ (in integer) is ____ V.

Ans. -12

Sol.

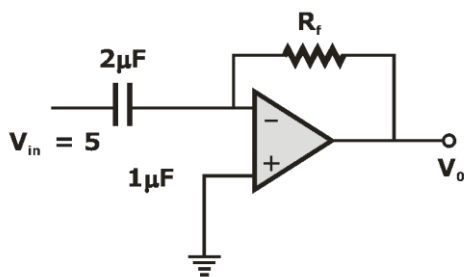

Apply miller's theorem

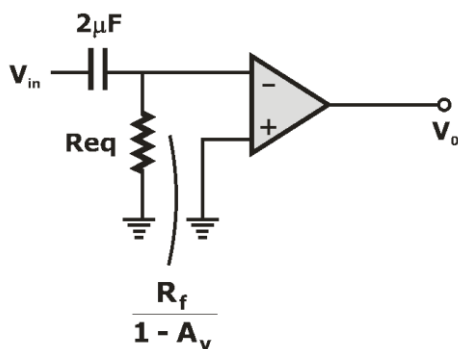

$$A_v = -\infty \therefore \frac{R_f}{1 - (-\infty)} = 0$$

$$\tau = R_{eq} C = 0$$

Ideal differentiator with 180° phase shift

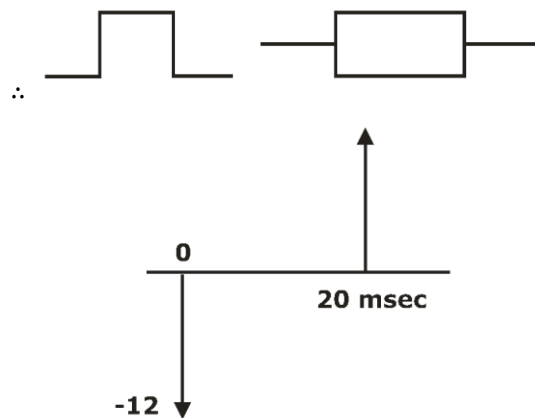

We are getting impulse at $t = 0$ and $t = 20 \text{ msec}$

for $t = 0^+ V_0 = -12 \text{ V}$

$$\therefore \delta(t) = \begin{cases} \neq 0 & t = 0 \\ = 0 & t \neq 0 \end{cases}$$

13. A speech signal band limited to 4 kHz, is sampled at 1.25 times the Nyquist rate. The speech samples, assumed to be statistically independent and uniformly distributed in the range -5 V to +5 V, are subsequently quantized in an 8-bit uniform quantizer and then transmitted over a voice-grade AWGN telephone channel. If the ratio of transmitted signal power to channel noise power is 26 dB, the minimum channel bandwidth required to ensure reliable transmission of the signal with arbitrarily small probability of transmission error (rounded off to two decimal places) is ____ kHz.

Ans. 9.25

$$\text{Sol. } C = B \log_2 \left(1 + \frac{S}{N} \right)$$

If $C \geq R_b$, we don't get error

$$B \log_2 \left(1 + \frac{S}{N} \right) \geq R_b$$

$$B \geq \frac{R_b}{\log_2 \left(1 + \frac{S}{N} \right)} \geq \frac{nfs}{\log_2 \left(1 + \frac{S}{N} \right)}$$

$$B \geq \frac{n \times 1.25(2) f_m}{\log_2 \left(1 + \frac{S}{N} \right)}$$

$$B \geq \frac{8 \times (1.25) 8000}{\log_2 (1 + 10^{2.6})}$$

$$10 \log \frac{S}{N} = 26$$

$$\log \frac{S}{N} = 2.6$$

$$\frac{S}{N} = 10^{2.6}$$

$$B \geq \frac{80,000}{\log_2 (1 + 10^{2.6})} \geq \frac{80,000}{8640} \geq 9259.25$$

$$B \geq 9.259 \text{ kHz}$$

$$B_{\min} = 9.25 \text{ kHz}$$

- 14.** For a unit step input $u[n]$, a discrete-time LTI system produces an output signal $(2\delta[n + 1] + \delta[n] + \delta[n-1])$. Let $y[n]$ be the output of the system for an input $\left(\left(\frac{1}{2} \right)^n u[n] \right)$. The value of

$y[0]$ is _____

Ans. 0

Sol.

$$u[n] \longrightarrow \boxed{h[n]} \longrightarrow 2\delta[n + 1] + \delta[n] + \delta[n - 1]$$

$$u[n] \xrightarrow{\text{Z.T.}} \frac{z}{z-1}$$

$$2\delta[n + 1] + \delta[n] + \delta[n - 1] \xrightarrow{\text{Z.T.}} 2z + 1 + z^{-1}$$

$$= 2z + 1 + \frac{1}{z}$$

$$= \left(\frac{2z^2 + z + 1}{z} \right)$$

$$\text{Now, } H(z) = \left(\frac{2z^2 + z + 1}{z} \right) / \left(\frac{z}{z-1} \right)$$

$$H(z) = \frac{(z-1)(2z^2 + z + 1)}{z^2}$$

$$H(z) = \frac{2z^3 - z^2 - 1}{z^2}$$

$$H(z) = 2z - 1 - z^{-2}$$

$$h[n] = 2\delta[n + 1] - \delta[n] - \delta[n - 2]$$

$$x[n] \longrightarrow \boxed{h[n]} \longrightarrow y[n]$$

$$x[n] = \left(\frac{1}{2} \right)^n \cdot u[n], \quad h[n] = 2\delta[n + 1] -$$

$$\delta[n] - \delta[n - 2]$$

$$y[n] = x[n] * h[n]$$

$$y[n] = x[n] * [2\delta[n + 1] - \delta[n] - \delta[n - 1]]$$

$$y[n] = 2x[n + 1] - x[n] - x[n - 2]$$

$$y[n] = 2 \left(\frac{1}{2} \right)^{n+1} \cdot u[n+1] - \left(\frac{1}{2} \right)^n \cdot u[n] - \left(\frac{1}{2} \right)^{n-2} \cdot u[n-2]$$

$$y[0] = 2 \left(\frac{1}{2} \right)^1 \cdot u[1] - \left(\frac{1}{2} \right)^0 \cdot u[0] - \left(\frac{1}{2} \right)^{-2} \cdot u[-2]$$

$$y[0] = 1 - 1 - 0$$

$$y[0] = 0$$

- 15.** Consider a polar non-return to zero (NRZ) waveform using +2 V and -2 V for representing binary '1' and '0' respectively, is transmitted in the presence of additive zero-mean white Gaussian noise with variance 0.4 V^2 . If the a priori probability of transmission of a binary '1' is 0.4, the optimum threshold voltage for a maximum a posteriori (MAP) receiver (rounded off to two decimal places) is _____ V.

Ans. 0.04

Sol. Given NRZ waveform taken 2 values +2V and -2V

$$\text{Binary 1} \rightarrow +2V \rightarrow a_1$$

$$\text{Binary 0} \rightarrow -2V \rightarrow a_2$$

$$\text{variance } \sigma^2 \rightarrow 0.4 \text{ V}^2$$

$$P[x = 1] = 0.4$$

$$P[x = 0] = 0.6$$

$$V_{th} = \frac{a_1 + a_2}{2} + \frac{\sigma^2}{a_1 - a_2} \ln \left[\frac{P(0)}{P(1)} \right]$$

$$= \frac{2 - 2}{2} + \frac{0.4}{4} \ln \left[\frac{0.6}{0.4} \right]$$

$$V_{th} = 0.04$$

- 16.** A sinusoidal message signal having root mean square value of 4 V and frequency of 1 kHz is fed to a phase modulator with phase deviation constant 2 rad/volt. If the carrier signal is $c(t) = 2 \cos(2\pi 10^6 t)$, the maximum instantaneous frequency of the phase modulated signal (rounded off to one decimal place) is _____ Hz.

Ans. 1011313.7

Sol. $m(t)_{rms} = 4V$

$$\frac{d}{dt} m(t) = 4\sqrt{2} \times 2\pi \times 10^3 \cos(2\pi \times 10^3 t)$$

$$m(t) = 4\sqrt{2}$$

$$\frac{dm(t)}{dt} = 4\sqrt{2} \times 2\pi \times 10^3$$

$$K_p = 2 \text{ rad / volt}$$

$$\text{PM: } \theta(t) = \omega_c t + k_p m(t)$$

$$\omega_i(t) = \omega_c + k_p \frac{dm(t)}{dt}$$

$$f_{Maximum} = f_c + \frac{K_p}{2\pi} \cdot \left[\frac{dm(t)}{dt} \right]$$

$$f_{Maximum} = 1000 \times 10^3 + \frac{2}{2\pi} \times 4\sqrt{2} 2\pi \times 10^3$$

$$f_{Maximum} = (1000 + 8\sqrt{2}) \text{ kHz}$$

$$f_{Maximum} = (1000 + 11.3137) \text{ kHz}$$

$$f_{Maximum} = 1011.3137 \text{ kHz}$$

- 17.** The exponential Fourier series representation of a continuous-time periodic signal $x(t)$ is defined as

$$X(t) = \sum_{k=-\infty}^{\infty} a_k e^{jk\omega_0 t}$$

Where ω_0 is the fundamental angular frequency of $x(t)$ and the coefficients of the series are a_k . The following information is given about $x(t)$ and a_k .

I. $X(t)$ $x(t)$ is real and even, having a fundamental period of 6

II. The average value of $x(t)$ is 2

$$\text{III. } a_k = \begin{cases} k, & 1 \leq k \leq 3 \\ 0, & k > 3 \end{cases}$$

The average power of the signal $x(t)$ (rounded off to one decimal place) is _____

Ans. 32

Sol. (I) $x(t) \xrightarrow{\text{C.T.F.S.}} a_k$

Real + Even

Real + Even

$$\therefore a_{-k} = a_k^*$$

But a_k is real

$$\therefore a_{-k} = a_k \text{ (1)}$$

$$\text{II. } a_0 = 2$$

$$\text{III. } a_k = \begin{cases} k; & k = 1, 2, 3 \\ 0; & \text{otherwise} \end{cases}$$

$$a_1 = a_{-1} = 1$$

$$a_2 = a_{-2} = 2$$

$$a_3 = a_{-3} = 3$$

$$a_4 = a_{-4} = 0$$

$$a_5 = a_{-5} = 0$$

-

-

-

$$P_{avg} = \sum_{k=-\infty}^{\infty} |a_k|^2$$

$$= a_0^2 + a_1^2 + a_{-1}^2 + a_2^2 + a_{-2}^2 + a_3^2 + a_{-3}^2$$

$$= 2^2 + 1^2 + 1^2 + 2^2 + 2^2 + 3^2 + 3^2$$

$$= 4 + 1 + 1 + 4 + 4 + 9 + 9$$

$$= 32 \text{ Watts}$$

18. The vector function $F(r) = -x \hat{i} + y \hat{j}$ is defined over a circular arc C shown in the figure.

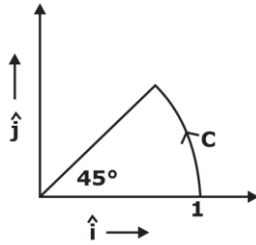

The line integral of $\int_C F(r) \cdot dr$ is

- A. $\frac{1}{6}$ B. $\frac{1}{2}$
 C. $\frac{1}{4}$ D. $\frac{1}{3}$

Ans. B

Sol. $\vec{F}(r) = -x \hat{i} + y \hat{j}$

$$\begin{aligned} & \int_C \vec{F}(r) \cdot d\vec{r} \\ &= \int_C (-x \hat{i} + y \hat{j}) (dx \hat{i} + dy \hat{j}) \\ &= \int_C (-x dx + y dy) \end{aligned}$$

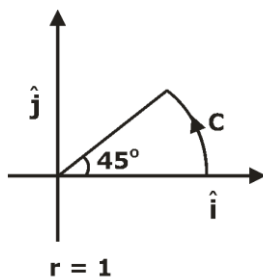

$x = r \cos \theta = \cos \theta$	$y = r \sin \theta = \sin \theta$
$dx = -\sin \theta d\theta$	$dy = \cos \theta d\theta$

$$\begin{aligned} &= \int_{\theta=0}^{\pi/4} -\cos \theta (-\sin \theta) \cdot d\theta + \sin \theta \cos \theta d\theta \\ &= \int_0^{\pi/4} 2 \sin \theta \cdot \cos \theta d\theta \\ &= \int_0^{\pi/4} \sin 2\theta d\theta \end{aligned}$$

$$\begin{aligned} &= -\left[\frac{\cos 2\theta}{2} \right]_0^{\pi/4} \\ &= -\frac{1}{2} [0 - 1] = \frac{1}{2} \end{aligned}$$

19. A digital transmission system uses a (7,4) systematic linear Hamming code for transmitting data over a noisy channel. If three of the message -codeword pairs in this code ($m_i ; c_i$) where c_i is the codeword corresponding to the i^{th} message m_i , are known to be (1100;0101100), (1110;0022220) and (0110 ; 1000110), then which of the following is a valid codeword in this code?

- A. 0110100 B. 1011010
 C. 0001011 D. 1101001

Ans. C

Sol. Given code is systematic linear hamming code of order (7, 4)

Given message and code word pairs are

1100; 0101100

1110; 0011110

0110; 1000110

The code word is of the form

$p_1 p_2 p_3 d_1 d_2 d_3 d_4$

where $P_1 = d_1 \oplus d_2 \oplus d_4$

$P_2 = d_2 \oplus d_3 \oplus d_4$

$P_3 = d_1 \oplus d_2 \oplus d_3$

The code word which satisfies this pattern is

0001011

\therefore option 'C' (or) option '3' is answer.

20. If the vectors (1.0, -1.0, 2.0), (7.0, 3.0, x) and (2.0, 3.0, 1.0) in R^3 are linearly dependent the value of x is _____

Ans. 8

Sol. Given vectors are

$x_1 = [1 \ -1 \ 2]$

$x_2 = [7, \ 3 \ x]$

$$x_3 = [2 \ 3 \ 1]$$

are linearly dependent

$$\text{Let } A = [X_1^T X_2^T X_3^T]$$

$$A = \begin{bmatrix} 1 & 7 & 2 \\ -1 & 3 & 3 \\ 2 & x & 1 \end{bmatrix}_{3 \times 3}$$

Rank (A) < order of 3

∴ rank (A) < 3

⇒ A should be singular matrix $|A| = 0$

$$\Rightarrow \begin{vmatrix} 1 & 7 & 2 \\ -1 & 3 & 3 \\ 2 & x & 1 \end{vmatrix} = 0$$

$$\Rightarrow 1 \times (3 - 3x) - 7x(-1 - 6) + 2 \times (-x - 6) = 0$$

$$\Rightarrow -5x + 40 \Rightarrow x = 8$$

- 21.** A standard air-filled rectangular waveguide with dimensions $a = 8$ cm, $b = 4$ cm, operates at 3.4 GHz. For the dominant mode of wave propagation, the phase velocity of the signal is v_p . The value (rounded off to two decimal places) of v_p/c , where c denotes the velocity of light, is _____

Ans. 1.1987

Sol. $a = 8$ cm, $b = 4$ cm

dominant mode = TE₁₀

$$f_c = \frac{c}{2a} = \frac{3 \times 10^{10}}{2 \times 8} = \frac{30}{16} \times 10^9 = 1.875 \text{ GHz}$$

Opening frequency $f = 3.4$ GHz

$$\begin{aligned} \cos \theta &= \sqrt{1 - \left(\frac{f_c}{f}\right)^2} = \sqrt{1 - \left(\frac{1.875}{3.4}\right)^2} \\ &= \sqrt{1 - (0.5514)^2} = \sqrt{1 - 0.3040} \end{aligned}$$

$$\cos \theta = \sqrt{0.696} = 0.8342$$

$$\frac{V_p}{c} = \frac{1}{0.8342} = 1.1987$$

- 22.** Consider the differential equation given below.

$$\frac{dy}{dx} + \frac{x}{1-x^2}y = x\sqrt{y}$$

The integrating factor of the differential equation is

A. $(1-x^2)^{-3/2}$

B. $(1-x^2)^{-3/4}$

C. $(1-x^2)^{-1/2}$

D. $(1-x^2)^{-1/4}$

Ans. D

Sol. $\frac{1}{\sqrt{y}} \frac{dy}{dx} + \frac{x}{(1-x^2)}\sqrt{y} = x$

$$\sqrt{y} = v$$

$$\frac{1}{2\sqrt{y}} \frac{dy}{dx} = \frac{dv}{dx}$$

$$\frac{1}{\sqrt{y}} \frac{dy}{dx} = 2 \frac{dv}{dx}$$

$$\Rightarrow 2 \frac{dv}{dx} + \frac{x}{(1-x^2)}v = x$$

$$\Rightarrow \frac{dv}{dx} + \frac{x}{2(1-x^2)}v = \frac{x}{2}$$

$$P = \frac{x}{2(1-x^2)} \text{ and } Q = \frac{x}{2}$$

$$\text{I.F.} = e^{\int P \cdot dx}$$

$$= e^{\frac{1}{2} \int \frac{x}{1-x^2} dx}$$

$$= e^{-\frac{1}{4} \int \frac{-2x}{(1-x^2)} dx}$$

$$= e^{-\frac{1}{4} \log e^{(1-x^2)}}$$

$$= e \log e (1-x)^{-\frac{1}{4}}$$

$$\text{I.F.} = (1-x^2)^{-\frac{1}{4}}$$

- 23.** A 4 kHz sinusoidal message signal having amplitude 4 V is fed to a delta modulator (DM) operating at a sampling rate of 32 kHz. The minimum step size required to avoid slope overload noise in the DM (rounded off to two decimal places) is _____ V.

Ans. 3.14

Sol. $\Delta = \frac{2\pi f_m A_m}{f_s} = \frac{(2\pi)(4k)(4)}{32k} = \pi$ volt

$$= 3.14 \text{ volt}$$

24. Consider the circuit shown in the figure.

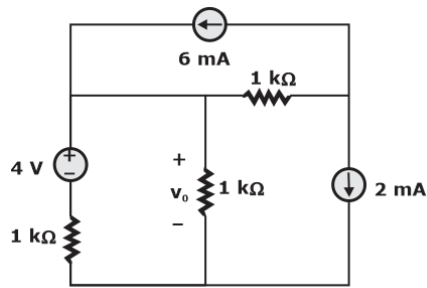

The value of v_0 (rounded off to one decimal place) is ____ V.

Ans. 1

Sol.

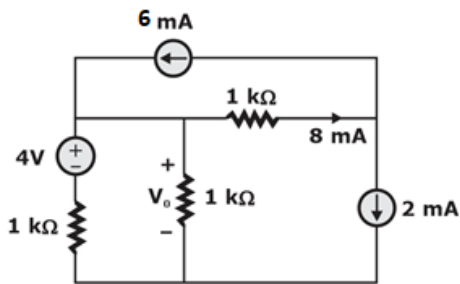

Apply KCL,

$$\frac{V_0 - 4}{1} + \frac{V_0}{1} + 8 - 6 = 0$$

$$2V_0 - 4 + 2 = 0$$

$$V_0 = 1 \text{ Volt}$$

25. Consider the integral

$$\oint_C \frac{\sin(x)}{x^2(x^2+4)} dx$$

Where C is a counter-clockwise oriented circle defined as $|x - i| = 2$. The value of the integral is

- A. $-\frac{\pi}{8} \sin(2i)$ B. $-\frac{\pi}{4} \sin(2i)$
 C. $\frac{\pi}{4} \sin(2i)$ D. $\frac{\pi}{8} \sin(2i)$

Ans. A

Sol. $Z = 0$ index 2

$$Z = \pm 2i$$

$$|(z-i)| = 2$$

$$|x + iy - i| = 2$$

$$x^2 + (y - 1)^2 = 2^2$$

$$\text{Cent } (0, 1) \text{ Rad.} = 2$$

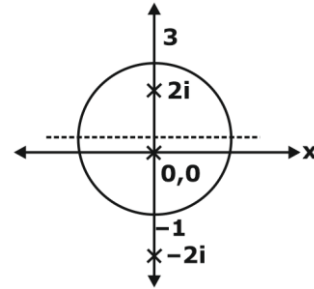

$$f(z) = \frac{\sin z}{z^2(z-2i)(z+2i)}$$

$$R_1 = \frac{1}{1!} \lim_{z \rightarrow 0} \frac{d}{dz} z^2 \frac{\sin z}{z^2(z^2+4)}$$

$$R_1 = \lim_{z \rightarrow 0} \frac{(z^2 + 4) \cos z - \sin z(2z)}{(z^2 + 4)^2}$$

$$R_1 = \frac{4 - 0}{16} = \frac{1}{4}$$

$$R_2 = \lim_{z \rightarrow 2i} \frac{\sin z}{z^2(z+2i)} = \frac{-\sin(2i)}{4 \times 4i} = \frac{+i \sin(2i)}{16}$$

By Cauchy's Residue theorem,

$$\oint_C \frac{\sin z}{z^2(z^2+4)} dz = 2\pi i [R_1 + R_2]$$

$$= 2\pi i \left[\frac{1}{4} + i \frac{\sin(2i)}{16} \right]$$

26. In high school having equal number of boy students and girls, 75% of the students study Science and the remaining 25% students study Commerce. Commerce students are two times more likely to be a boy than are Science students. The amount of information gained in knowing that a randomly selected girl student studies Commerce (rounded off to three decimal places) is ____ bits

Ans. 2807 bits

Sol. Prob. of Science student

$$P(S) = \frac{3}{4}$$

Prob. of Commerce student

$$P(C) = \frac{1}{4}$$

$$P\left[\frac{B}{C}\right] = \frac{2}{3}; \text{ Prob. that boy student is}$$

commerce

$$P\left[\frac{B}{S}\right] = \frac{1}{3}; \text{ prob. that girl student is}$$

commerce

$$P\left[\frac{G}{C}\right] = \frac{1}{3}; P\left[\frac{G}{S}\right] = \frac{2}{3}$$

$$P(G) = P(S) \cdot P\left[\frac{G}{S}\right] + P(C) \cdot P\left[\frac{G}{C}\right]$$

$$P\left[\frac{C}{G}\right] = \frac{P(G \cap C)}{P(G)} = \frac{P(C) P\left[\frac{G}{C}\right]}{P(G)}$$

$$= \frac{\frac{1}{4} \times \frac{1}{3}}{\frac{3}{4} \times \frac{2}{3} + \frac{1}{4} \times \frac{1}{3}} = \frac{\frac{1}{12}}{\frac{12}{7}} = \frac{1}{7}$$

$$I = \log_2 \frac{1}{P}$$

$$I = \log_2 7$$

$$I = 2.807 \text{ bits}$$

- 27.** Consider the vector field $F = a_x (4y - c_1z) + a_y(4x + 2z) + a_z(2y + z)$ in a rectangular coordinate system (x,y,z) with unit vectors a_x , a_y , and a_z . If the field F is irrotational (conservative), then the constant c_1 (in integer) is _____

Ans. 0

$$\text{Sol. } \vec{F} = (4y - C_1z) \hat{a}_x + (4x + 2z) \hat{a}_y + (2y + z) \hat{a}_z$$

$\therefore \vec{F}$ is irrotational

$$\therefore \text{curl } \vec{F} = 0$$

$$\vec{\nabla} \times \vec{F} = 0$$

$$\Rightarrow \begin{vmatrix} \hat{a}_x & \hat{a}_y & \hat{a}_z \\ \partial / \partial x & \partial / \partial y & \partial / \partial z \\ (4y - C_1z) & (4x + 2z) & (2y + z) \end{vmatrix} = \vec{0}$$

$$\Rightarrow \hat{a}_x \left[\frac{\partial}{\partial y} (2y + z) - \frac{\partial}{\partial z} (4x + 2z) \right]$$

$$- \hat{a}_y \left[\frac{\partial}{\partial x} (2y + z) - \frac{\partial}{\partial z} (4y - C_1z) \right]$$

$$+ \hat{a}_z \left[\frac{\partial}{\partial x} (4x + 2z) - \frac{\partial}{\partial y} (4y - C_1z) \right] = \vec{0}$$

$$\Rightarrow \hat{a}_x [2 - 2] - \hat{a}_y [0 + C_1] + \hat{a}_z [4 - 4] = \vec{0}$$

$$\Rightarrow 0 \hat{a}_x - C_1 \hat{a}_y + 0 \hat{a}_z = \vec{0}$$

$$C_1 = 0$$

- 28.** The content of the registers are $R_1 = 25H$, $R_2 = 30H$ and $R_3 = 40H$. The following machine instructions are executed.

PUSH{R1}

PUSH{R2}

PUSH{R3}

POP{R1}

POP{R2}

POP{R3}

After execution, the content of registers R_1 , R_2 , R_3 are

- A. $R_1 = 40H$, $R_2 = 25H$, $R_3 = 30H$
- B. $R_1 = 40H$, $R_2 = 30H$, $R_3 = 25H$
- C. $R_1 = 30H$, $R_2 = 40H$, $R_3 = 25H$
- D. $R_1 = 25H$, $R_2 = 30H$, $R_3 = 40H$

Ans. B

Sol. $R_1 = 25H$, $R_2 = 30H$, $R_3 = 40H$

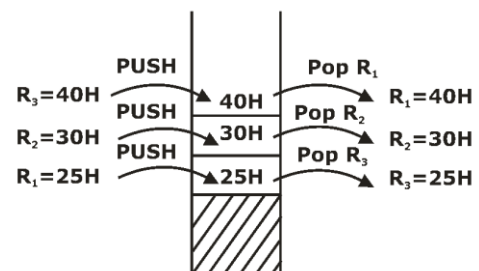

PUSH and POP instruction is used in stack which is based on last IN first out [LIFO]
Option (B) is correct

$$R_1 = 40H$$

$$R_2 = 30H$$

$$R_3 = 25H$$

29. For the transistor M_1 in the circuit shown in the figure, $\mu_n C_{ox} = 100 \mu A/V^2$ and $(W/L) = 10$, where μ_n is the mobility of electron. C_{ox} is the oxide capacitance per unit area. W is the width and L is the length.

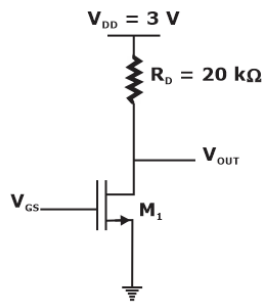

The channel length modulation coefficient is ignored. If the gate-to-source voltage V_{GS} is 1 V to keep the transistor at the edge of saturation, then the threshold voltage of the transistor (rounded off to one decimal place) is _____ V.

Ans. 0.5 V

Sol.

$$V_{DS} = 3 - 20I_D$$

$$I_D = \frac{1}{2} k_n' \frac{W}{L} (V_{GS} - V_t)^2$$

$$I_D = \frac{1}{2} \times 0.1 \times 10 \times V_{DS}^2$$

At Boundary of triode and saturation

$$V_{DS} = V_{GS} - V_t$$

$$V_{DS} = 3 - 20I_{DS}$$

$$20I_{DS} = 3 - V_{DS}$$

$$I_{DS} = \frac{3 - V_{DS}}{20} = \frac{1}{2} \times 0.1 \times 10 \times V_{DS}^2$$

by solving above equation $V_{th} = 0.5V$

30. For a vector field $D = \rho \cos^2 \Phi a_\rho + z^2 \sin^2 \Phi a_\phi$ in a cylindrical coordinates system (ρ, Φ, z) with unit vectors a_ρ, a_ϕ and a_z , the net flux of D leaving the closed surface of the cylinder $(\rho=3, 0 \leq z \leq 2)$ (rounded off to two decimal places) is _____

Ans. 56.54

Sol. $D = \rho \cos^2 \phi a_\rho + z^2 \sin^2 \phi a_\phi$

$$\psi = \int_S \vec{D} \cdot d\vec{s} = \int_V (\nabla \cdot \vec{D}) dv$$

$$\nabla \cdot \vec{D} = \frac{1}{\rho} \left[\frac{\partial}{\partial \rho} [\rho^2 \cos^2 \phi] + \frac{\partial}{\partial \phi} [z^2 \sin^2 \phi] \right]$$

$$= \frac{1}{\rho} [2\rho \cos^2 \phi + z^2 2 \sin \phi \cos \phi]$$

$$= \frac{1}{\rho} [2\rho \cos^2 \phi + z^2 \sin 2\phi]$$

$$dv = \rho d\rho d\phi dz$$

$$\psi = \iiint \frac{1}{\rho} [2\rho \cos^2 \phi + z^2 \sin 2\phi] \rho d\rho d\phi dz$$

$$\psi = \iiint [2\rho \cos^2 \phi d\rho d\phi dz + z^2 \sin 2\phi d\rho d\phi dz]$$

$$= 2 \left[\frac{\rho^2}{2} \right]_{\rho=3} \int \cos^2 \phi d\phi [z]_0^2 +$$

$$[\rho]_{\rho=3} \left[\frac{\cos 2\phi}{2} \right]_0^2 \left[\frac{z^3}{3} \right]_0^2$$

$$= 9[\pi]2 + \left[3 \times [0] \left[\frac{8}{3} \right] \right] = 18\pi$$

$$\boxed{\psi = 56.54 \text{ C}}$$

31. Consider a carrier signal which is amplitude modulated by a single-tone sinusoidal message signal with a modulation index of 50%. If the carrier and one of the sidebands are suppressed in the modulated signal. The percentage of power saved (rounded off to one decimal place) is _____

Ans. 94.44

Sol. Carrier and sideband is removed then it is SSB

Percentage Power saving =

$$= \frac{1 + \frac{\mu^2}{4}}{1 + \frac{\mu^2}{2}} \times 100 = \frac{1 + \frac{1}{16}}{1 + \frac{1}{8}} \times 100$$

$$= \frac{1.0625}{1.125} \times 100 = 94.4\%$$

Percentage Power saving = 94.44%

- 32.** Consider a super heterodyne receiver tuned to 600 kHz. If the local oscillator feeds a 1000 kHz signal to the mixer, the image frequency (in integer) is ____ kHz.

Ans. 1400

Sol. $F_{L0} > F_{RF}$

$$F_{L0} = F_{RF} + F_{IF}$$

$$1000 = 600 + F_{IF} \Rightarrow F_{IF} = 400 \text{ kHz}$$

$$F_{Image} = F_{fs} + 2 F_{IF}$$

$$F_{Image} = 600 + 2(400) = 1400 \text{ kHz}$$

- 33.** A box contains the following three coins.

I. A fair coin with head on one face and tail on the other face.

II. A coin with heads on both the faces.

III. A coin with tails on both the faces.

A coin is picked randomly from the box and tossed. Out of the two remaining coins in the box, one coin is then picked randomly and tossed. If the first toss results in a head the probability of getting a head in the second toss is

- A. $\frac{2}{3}$ B. $\frac{1}{3}$
 C. $\frac{2}{5}$ D. $\frac{1}{2}$

Ans. B

Sol. $p(H_2/H_1) = \frac{p(H_2 \cap H_1)}{p(H_1)}$

$$p(H_1) = \frac{1}{3} \times \frac{1}{2} + \frac{1}{3} \times 1 + \frac{1}{3} \times 0 = \frac{1}{6} + \frac{1}{3} = \frac{1}{2}$$

$$p(H_2 \cap H_1) \Rightarrow (1) C_1 C_2 \text{ or } C_2 C_1$$

$$\left[\frac{1}{3} \times \frac{1}{2} \times 1 \times \frac{1}{2} \right] + \left[\frac{1}{3} \times \frac{1}{2} \times \frac{1}{2} \times 1 \right] = \frac{1}{6}$$

$$C_2 C_3 \rightarrow 0$$

$$C_1 C_3 \rightarrow 0$$

$$\text{Ans} = \frac{1/6}{1/2} = \frac{1}{3}$$

- 34.** The block diagram of a feedback control system is shown in the figure.

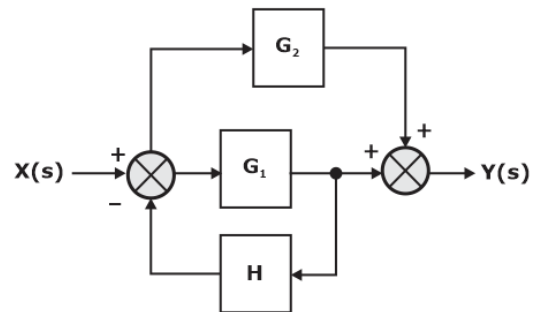

The transfer function $\frac{Y(s)}{X(s)}$ of the system is

- A. $\frac{G_1 + G_2}{1 + G_1 H}$ B. $\frac{G_1 + G_2 + G_1 G_2 H}{1 + G_1 H}$
 C. $\frac{G_1 + G_2 + G_1 G_2 H}{1 + G_1 H + G_2 H}$ D. $\frac{G_1 + G_2}{1 + G_1 H + G_2 H}$

Ans. A

Sol. Sketching the SFG

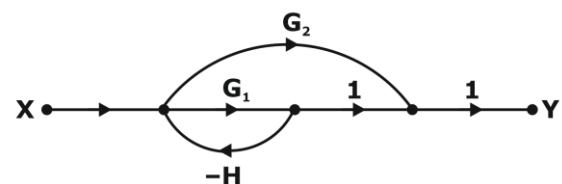

By Mason's gain formula,

$$\frac{Y}{X} = \frac{G_1 \times 1 + G_2 \times 1}{1 - (-G_1 H)}$$

$$\frac{Y}{X} = \frac{G_1 + G_2}{1 + G_1 H}$$

35. The impedance matching network shown in the figure is to match a lossless line having characteristic impedance $Z_0 = 50 \Omega$ with a load impedance Z_L . A quarter-wave line having a characteristic impedance $z_1 = 75 \Omega$ is connected to Z_L . Two stubs having characteristic impedance of 75Ω each are connected to this quarter-wave line. One is a short-circuited (S.C) stub of length 0.25λ connected across PQ and the other one is an open-circuited (O.C) stub of length 0.5λ connected across RS.

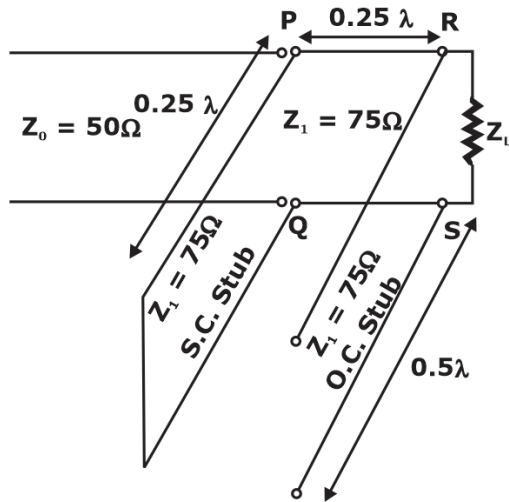

The impedance matching is achieved when the real part of Z_L is

- A. 75.0Ω B. 50.0Ω
 C. 33.3Ω D. 112.5Ω

Ans. D

Sol. O.C $\lambda/2$ line $Z_{in} = Z_L \rightarrow$ neglect o.c. line

S.C. $\lambda/4$ line $Z_{in} = \frac{z_0^2}{z_L} = \infty \rightarrow$ neglect S.C. line.

$$Z_{in} = \frac{75^2}{R_L} \parallel \infty = \frac{5625}{R_L} = Z_{PQ}$$

$$k_q = \frac{Z_{PQ} - 50}{Z_{PQ} + 50} = 0 \Rightarrow Z_{PQ} = 50$$

$$R_L = \frac{5625}{50} = 112.5 \Omega$$

36. The complete Nyquist plot of the open-loop transfer function $G(s) H(s)$ of a feedback control system is shown in the figure.

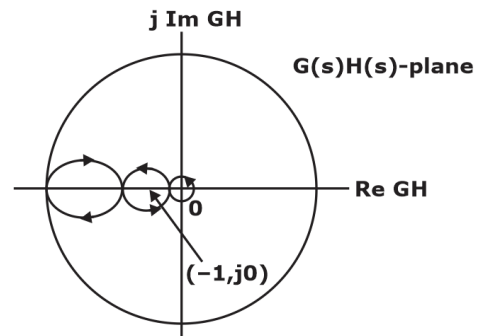

If $G(s) H(s)$ has one zero in the right-half of the s -plane, the number of poles that the closed-loop system will have in the right-half of the s -plane is

- A. 1 B. 0
 C. 3 D. 4

Ans. A

Sol. $N = P_+ - Z_+$

Always, $P_+ =$ No. of poles of $G(s) H(s)$ in RHP

If you take N as encirclement of $(-1, 0)$

Then $Z_+ =$ no. of zeros of $1 + G(s) H(s)$ in RHP
 $=$ no. of poles of CLTF in RHP

Given $Z_+ = 1$ [1 zero of $G(s) H(s)$ in RHP]

So, $N =$ no. of encirclement of $(0) = 2$ cw

So, $N = -2$

$N = P_+ - Z_+$

$-2 = P_+ - 1$

$P_+ = -1 \rightarrow$ which is not possible

So, given data is inconsistent.

The possibility is to consider anticlockwise contour. But the contour should be normally mentioned in the question because By default direction is clockwise.

37. In the circuit shown in the figure the switch is closed at time $t = 0$, while the capacitor is initially charged to -5 V (i.e., $v_c(0) = -5\text{V}$).

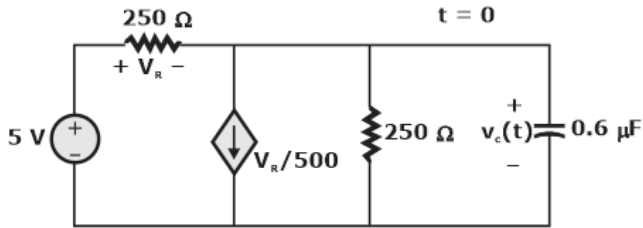

The time after which the voltage across the capacitor becomes zero (rounded off to three decimal places) is ____ ms.

Ans. 0.138

Sol.

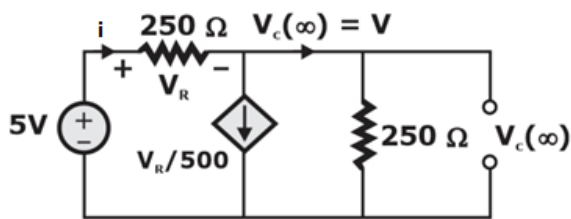

$$\frac{V_R}{500} + \frac{V}{250} = i$$

$$\left(\frac{5-V}{250}\right) \times 250 + \frac{V}{250} = \frac{5-V}{250}$$

$$\frac{5}{500} - \frac{V}{500} + \frac{V}{250} = \frac{5}{250} - \frac{V}{250}$$

$$\left(\frac{5}{500} - \frac{5}{250}\right) = \frac{V}{500} - \frac{V}{250} - \frac{V}{250}$$

$$\frac{-5}{500} = V \left[\frac{1}{500} - \frac{1}{250} - \frac{1}{250} \right]$$

$$\frac{-1}{100} = -\frac{3}{500} V$$

$$V = \frac{500}{300} = 1.67V$$

II.

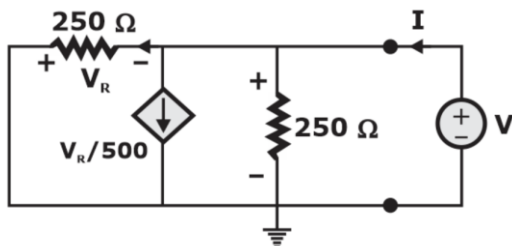

$$I = \frac{V}{250} + \frac{-V}{500} + \frac{V}{250}$$

$$= V \left[\frac{1}{250} - \frac{1}{500} + \frac{1}{250} \right]$$

$$I = 6 \times 10^{-3} V$$

$$R_{eq} = 166.67 \Omega$$

III.

$$T = R_{eq} \times C = 166.67 \times 0.6 \times 10^{-6}$$

$$T = 0.1 \text{ msec}$$

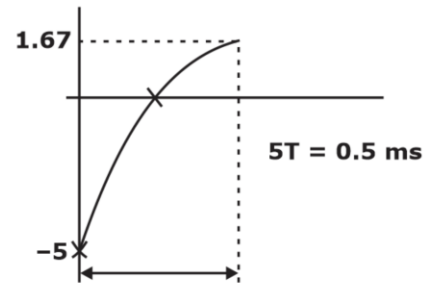

$$0 = 1.67 + (-5 - 1.67) e^{-\frac{t}{0.1 \times 10^{-3}}}$$

$$-1.67 = -6.67 e^{-\frac{t}{0.1 \times 10^{-3}}}$$

$$\ln(0.25) = \frac{-t}{0.1 \times 10^{-3}}$$

$$-1.38 = \frac{-t}{0.1}$$

$$t = 0.1 \times 1.38 \text{ m sec} = 0.138 \text{ ms}$$

- 38.** A message signal having peak-to-peak value of 2 V, root mean square value of 0.1 V and bandwidth of 5 kHz is sampled and fed to a pulse code modulation (PCM) system that uses a uniform quantizer. The PCM output is transmitted over a channel that can support a maximum transmission rate of 50 kbps. Assuming that the quantization error is uniformly distributed, the maximum signal to quantization noise ratio that can be obtained by the PCM system (rounded off to two decimal places) is ____

Ans. 30.72

Sol. Given message peak to peak value $V_{\max} - V_{\min} = 2V$

rms value is $\sqrt{\text{power}} = 0.1$

power = $(0.1)^2 = 0.01$ W

band width of signal is $f_m = 5$ kHz $\Rightarrow f_s = 2f_m$
= 10000 samples/sec

given $R_b = 50$ kbps

quantization error is uniformly distributed.

$$\therefore \text{noise power } N = \frac{\Delta^2}{12}$$

$$\Delta = \frac{V_{pp}}{L} = \frac{V_{\max} - V_{\min}}{2^n}$$

$$\Rightarrow N = \frac{V_{pp}^2}{2^{2n} \times 12} = \frac{4}{2^{2n} \times 12}$$

Signal power = 0.01 W

$$R_b = nf_s \Rightarrow n = \frac{R_b}{f_s} = \frac{50,000}{10,000} = 5$$

$$N = \frac{4}{2^{10} \times 12}$$

$$\frac{S}{N} = \frac{0.01}{4} \times 2^{10} \times 12$$

$$= 30.72$$

39. Addressing of a 32K x 16 memory is realized using a single decoder. The minimum number of AND gates required for the decoder is

- A. 2^{32} B. 2^{15}
C. 2^8 D. 2^{19}

Ans. B

Sol.

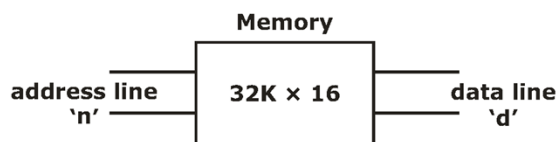

$$2^n \times d = 32k \times 16$$

$$= 2^{15} \times 16$$

$$d = 16, \quad n = 15 \leftarrow \text{address line}$$

$$\text{total no. of address location} = 2^{15}$$

$$\text{number of AND logic in decoder} = \text{total no of}$$

$$\text{address in memory} = 2^{15}$$

40. A bar of silicon is doped with boron concentration of 10^{16} cm^{-3} and assumed to be fully ionized. It is exposed to light such that electron-hole pairs are generated throughout the volume of the bar at the rate of $10^{20} \text{ cm}^{-3}\text{s}^{-1}$. If the recombination lifetime is 100 μs , intrinsic carrier concentration of silicon is 10^{10} cm^{-3} and assuming 100% ionization of boron, then the approximate product of steady-state electron and hole concentrations due to this light exposure is

- A. $2 \times 10^{20} \text{ cm}^{-6}$
B. 10^{32} cm^{-6}
C. 10^{20} cm^{-6}
D. $2 \times 10^{32} \text{ cm}^{-6}$

Ans. D

Sol. Boron \rightarrow trivalent impurity

$$N_A = 10^{16} \text{ cm}^{-3}$$

$$\therefore 100\% \text{ ionization } \therefore P = N_A = 10^{16} \text{ cm}^{-3} \quad (1)$$

$$n_p = n_i^2 / p = \frac{n_i^2}{N_A} = \frac{(10^{10})^2}{10^{16}} = 10^4 \quad (2)$$

$n_p \rightarrow$ concentration of electron in p type bar.

Now bar is exposed to light

New electron hole pair [EHP] will generated.

$$N_o = P_o = \text{rate of generation} \times \tau$$

$$= 10^{20} \times 100 \times 10^{-6} = 10^{16} / \text{cm}^3$$

Total hole concentration $P' = P + P_o$

$$= 10^{16} + 10^{16} = 2 \times 10^{16} \text{ (cm}^{-3}\text{)}$$

Total e^- concentration = $n_p + n_o$

$$n^1 = 10^4 + 10^{16} \cong 10^{16}$$

$$\text{product} = p^1 n^1 = 2 \times 10^{16} \times 10^{16} = 2 \times 10^{32} \text{ cm}^{-6}$$

41. The electrical system shown in the figure converts input source current $i_s(t)$ to output voltage $v_o(t)$

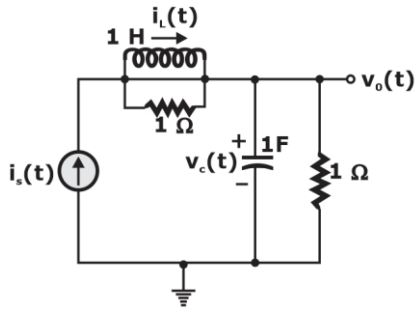

Current $i_L(t)$ in the inductor and voltage $v_c(t)$ across the capacitor are taken as the state variables, both assumed to be initially equal to zero, i.e., $i_L(0) = 0$ and $v_c(0) = 0$. The system is

- A. neither state controllable nor observable
- B. completely state controllable but not observable
- C. completely observable but not state controllable
- D. completely state controllable as well as completely observable

Ans. A

Sol. $i_s = i_L + \frac{V_L}{1}$

$$i_s = i_L + L \frac{di_L}{dt} \quad \dots (1)$$

$$i_s = i_c + \frac{V_C}{1}$$

$$i_c = C \frac{dv_c}{dt} \quad \dots (2)$$

Let $i_L = x_1$

$V_C = x_2$

$i_s = u = \text{input}$

$$1. \Rightarrow L \frac{d}{dt} x_1 + x_1 = u$$

$$\dot{x}_1 = \frac{-1}{L} x_1 + \frac{1}{L} u$$

$$2. \Rightarrow C \frac{d}{dt} x_2 + x_2 = u$$

$$\dot{x}_2 = -\frac{1}{C} x_2 + \frac{1}{C} u$$

Output, $y(t) = V_C(t) = x_2(t)$

So, we have

$$\dot{x} = \begin{bmatrix} -\frac{1}{L} & 0 \\ 0 & -\frac{1}{C} \end{bmatrix} x + \begin{bmatrix} \frac{1}{L} \\ \frac{1}{C} \end{bmatrix} u$$

$y = x_2$

$y = (0 \ 1) x$

Putting $L = 1H$ and $C = 1F$ we get

$$\dot{x} = \begin{bmatrix} -1 & 0 \\ 0 & -1 \end{bmatrix} x + \begin{bmatrix} 1 \\ 1 \end{bmatrix} u$$

$y = x_2$

$y = (0 \ 1) x$

Controllability Matrix

$$S = [B \ AB] = \begin{bmatrix} 1 & -1 \\ 1 & -1 \end{bmatrix}$$

$|S| = 0 \Rightarrow$ uncontrollable

Observability Matrix

$$V = \begin{bmatrix} C \\ CA \end{bmatrix} = \begin{bmatrix} 0 & 1 \\ 0 & -1 \end{bmatrix}$$

$|V| = 0 \Rightarrow$ unobservable

- 42.** An antenna with a directive gain of 6 dB is radiating a total power of 16 kW. The amplitude of the electric field in free space at a distance of 8 km from the antenna in the direction of 6 dB gain (rounded off to three decimal places) is ____ V/m.

Ans. 0.244

Sol. $G_d = 6\text{dB} = 10^{0.6}$

$P_{\text{red}} = 16\text{kW}$

$R = 8 \text{ km}$

$$G_d(\theta, \phi) = \frac{4\pi U(\theta, \phi)}{P_{\text{rad}}} = \frac{4\pi r^2 P_{\text{avg}}}{P_{\text{rad}}}$$

$$G_d(\theta, \phi) = \frac{4\pi r^2 \frac{E_0^2}{2\eta}}{P_{\text{rad}}} \Rightarrow E_0 = \sqrt{\frac{G_d(\theta, \phi) P_{\text{rad}} 2\eta}{4\pi r^2}}$$

$$E_0 = \sqrt{\frac{(10)^{0.6} \times 16 \times 10^3 \times 2 \times 120\pi}{4\pi (8 \times 10^3)^2}} = 0.244 \text{ V/m}$$

43. Consider the circuit with an ideal OPAMP shown in the figure.

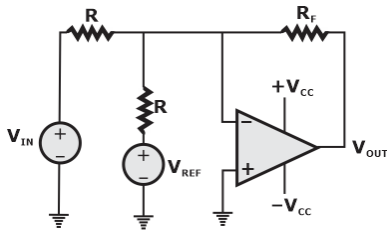

Assuming $|V_{IN}| \ll |V_{CC}|$ and $|V_{REF}| \ll |V_{CC}|$, the condition at which V_{OUT} equals to zero is

- A. $V_{IN} = V_{REF}$ B. $V_{IN} = 2 + V_{REF}$
 C. $V_{IN} = 0.5 V_{REF}$ D. $V_{IN} = 2 V_{REF}$

Ans. A

Sol. Apply Thevenin's theorem at inverting terminal.

$$V_{th} = \frac{V_{in}R}{R+R} - \frac{V_{ref}R}{R+R} = \frac{V_{in}}{2} - \frac{V_{ref}}{2}$$

$$R_{th} = R \parallel R = \frac{R}{2}$$

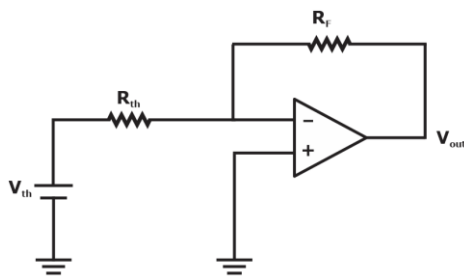

$$V_{out} = -\frac{R_f}{R_{th}} V_{th}$$

$$V_{out} = -\frac{R_f}{R} \left[\frac{V_{in}}{2} - \frac{V_{ref}}{2} \right] = 0$$

$$\therefore V_{in} = V_{ref}$$

44. The circuit in the figure contains a current source driving a load having an inductor and a resistor in series, with a shunt capacitor across the load. The ammeter is assumed to have zero resistance. The switch is closed at time $t = 0$.

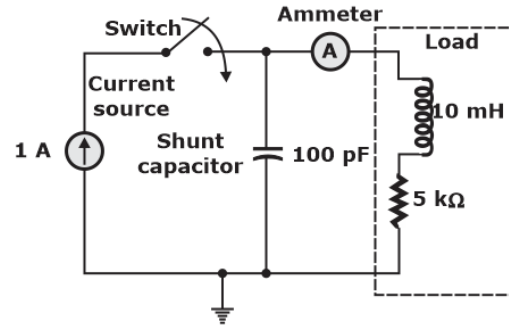

Initially, when the switch is open, the capacitor is discharged and the ammeter reads zero ampere. After the switch is closed, the ammeter reading keeps fluctuating for some time till it settles to a final steady value. The maximum ammeter reading that one will observe after the switch is closed (rounded off to two decimal places) is _____ A

Ans. 1.44

Sol.

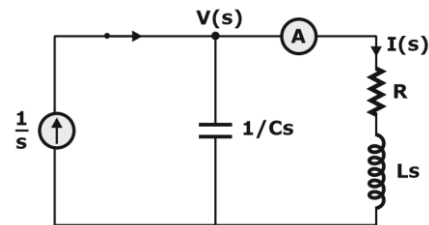

$$\frac{1}{s} = \frac{V(s)}{1/Cs} + \frac{V(s)}{(R+Ls)} \dots (i)$$

$$I(s) = \frac{V(s)}{(R+Ls)} \dots (ii)$$

$$\frac{1}{s} = V(s) \left[Cs + \frac{1}{R+Ls} \right]$$

$$V(s) = \frac{(R+Ls)}{s[Cs(R+Ls)+1]}$$

$$I(s) = \frac{1}{s[Lcs^2 + Rcs + 1]}$$

$$I(s) = \frac{1/LC}{s \left(s^2 + \frac{R}{L}s + \frac{1}{LC} \right)} = \frac{\omega_n^2}{s(s^2 + 2\xi\omega_n s + \omega_n^2)}$$

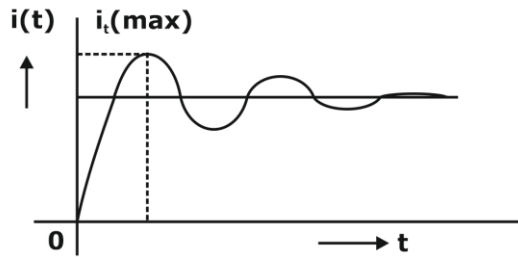

$$i(t)_{\max} = (i_{ss} + M_p)$$

$$M_p = e^{-\frac{\pi\xi}{\sqrt{1-\xi^2}}} = e^{-\pi \cot \phi}$$

$$M_p = 0.44$$

$$i(t)_{\max} = 1 + 0.44 = 1.44 \text{ Amp.}$$

- 45.** For an n-channel silicon MOSFET with 10 nm gate oxide thickness, the substrate sensitivity ($\partial V_T / \partial |V_{BS}|$) is found to be 50 mV/V at a substrate voltage $|V_{BS}| = 2 \text{ V}$, where V_T is the threshold voltage of the MOSFET. Assume that, $|V_{BS}| \gg 2\Phi_B$, where $q\Phi_B$ is the separation between the Fermi energy level E_F and the intrinsic level E_i in the bulk. Parameters given are

Electron charge (q) = $1.6 \times 10^{-19} \text{ C}$

Vacuum permittivity (ϵ_0) = $8.85 \times 10^{-12} \text{ F/m}$

Relative permittivity of silicon (ϵ_{Si}) = 12

Relative permittivity of oxide (ϵ_{Ox}) = 4

The doping concentration of the substrate is

- A. $2.37 \times 10^{15} \text{ cm}^{-3}$ B. $7.37 \times 10^{15} \text{ cm}^{-3}$
 C. $9.37 \times 10^{15} \text{ cm}^{-3}$ D. $4.37 \times 10^{15} \text{ cm}^{-3}$

Ans. B

Sol. Threshold voltage

$$V_T = V_{FB} + 2\phi_F + y\sqrt{2\phi_F + V_{BS}}$$

$$\text{Where } y = \frac{\sqrt{2q\epsilon_s N_A}}{C_{ox}} \quad (1)$$

$$C_{ox} = \frac{t_{ox}}{\epsilon_{ox}}$$

$$\therefore 2\phi_F \text{ or } 2\phi_B \ll |V_{BS}|$$

$$\therefore V_T = V_{FB} + y\sqrt{V_{BS}}$$

Diff. w.r.t. $|V_{BS}|$

$$\frac{dV_T}{d|V_{BS}|} = \frac{1}{2} \cdot y / \sqrt{|V_{BS}|} = \frac{1}{2} y / \sqrt{V_{BS}}$$

$$|V_{BS}| = 2\text{V}, \quad dV_T/d|V_{BS}| = 50 \text{ mV/V}$$

$$\therefore 50 = \frac{1}{2} y / \sqrt{2}$$

$$y = 50 \times 10^{-3} \times \sqrt{2} \times 2 \\ = 70.71 \times 10^{-3} \times 2 = 141.42 \times 10^{-3}$$

$$\text{From equation (1)} \quad N_A = \frac{(y C_{ox})^2}{2q\epsilon_s}$$

$$C_{ox} = \frac{\epsilon_{ox}}{t_{ox}} = \frac{4 \times 8.854 \times 10^{-12}}{10 \times 10^{-9}}$$

$$C_{ox} = 35.416 \times 10^{-4} \text{ F}$$

$$\epsilon_s = \epsilon_{Si} \epsilon_0 = 12 \times 8.854 \times 10^{-12}$$

$$\epsilon_s = 106.248 \times 10^{-12}$$

$$\therefore N_A = \frac{(70.71 \times 10^{-3} \times 35.416 \times 10^{-4} \times 2)^2}{2 \times 1.6 \times 10^{-19} \times 106.25 \times 10^{-12}}$$

$$N_A = 7.37 \times 10^{21} / \text{m}^3$$

$$N_A = 7.37 \times 10^{15} / \text{cm}^3$$

- 46.** A real 2×2 non-singular matrix A with repeated eigenvalue is given as

$$A = \begin{bmatrix} x & -3.0 \\ 3.0 & 4.0 \end{bmatrix}$$

Where x is a real positive number. The value of x (rounded off to one decimal place) is

Ans. 10

$$\text{Sol. } A = \begin{bmatrix} x & -3.0 \\ 3.0 & 4.0 \end{bmatrix}$$

\therefore eigen values of A are repeated

$$\therefore x + (-3) = 3 + 4$$

$$\Rightarrow x = 10$$

- 47.** Consider a rectangular coordinate system (x, y, z) with unit vectors a_x , a_y and a_z . A plane wave travelling in the region $z \geq 0$ with electric

field vector = $10 \cos(2 \times 10^8 t + \beta z) \mathbf{a}_y$ is incident normally on the plane at $z = 0$, where β is the phase constant. The region $z \geq 0$ is in free space and the region $z < 0$ is filled with a lossless medium (permittivity $\epsilon = \epsilon_0$, permeability $\mu = 4\mu_0$, where $\epsilon_0 = 8.85 \times 10^{-12}$ F/m and $\mu_0 = 4\pi \times 10^{-7}$ H/m). The value of the reflection coefficient is

- A. $\frac{1}{3}$ B. $\frac{3}{5}$
 C. $\frac{2}{5}$ D. $\frac{2}{3}$

Ans. A

Sol. Lossless medium

$$\mu = 4\mu_0$$

$$\eta_2 = 240\pi$$

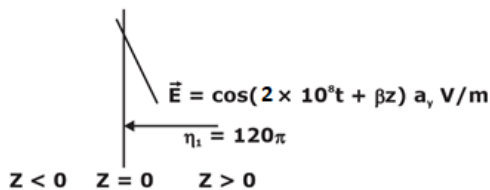

$$r = \frac{\eta_2 - \eta_1}{\eta_2 + \eta_1} = \frac{240\pi - 120\pi}{240\pi + 120\pi} = \frac{120\pi}{360\pi} = \frac{1}{3}$$

48. The propagation delay of the exclusive-OR (XOR) gate in the circuit in the figure is 3 ns. The propagation delay of all the flip-flops is assumed to be zero. The clock (Clk) frequency provided to the circuit is 500 MHz.

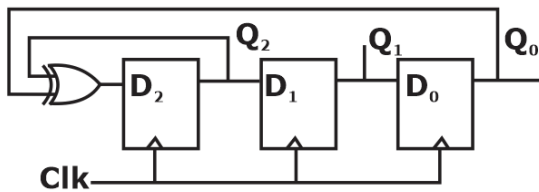

Starting from the initial value of the flip-flop outputs $Q_2 Q_1 Q_0 = 1 1 1$ with $D_2 = 1$, the minimum number of triggering clock edges after which the flip-flop outputs $Q_2 Q_1 Q_0$ becomes 1 0 0 (in integer) is _____

Ans. 5

Sol. $T_{CLK} = 2ns$

Propagation delay of X-OR gate = 3ns

$$D_2 = 1$$

CLOCK	Q_2	Q_1	Q_0
0	1	1	1
1.	1	1	1
2.	1	1	1
3.	0	1	1
4.	0	0	1
5.	1	0	0

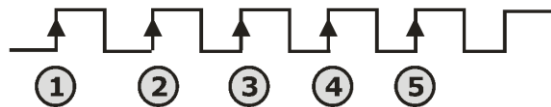

Number of triggered clock edge = 5

49. Consider the signals $x[n] = 2^{n-1} u[-n + 2]$ and $y[n] = 2^{-n+2} u[n + 1]$.

Where $u[n]$ is the unit step sequence. Let $X(e^{j\omega})$ and $Y(e^{j\omega})$ be the discrete-time Fourier transform of $x[n]$ and $y[n]$, respectively. The value of the integral

$$\frac{1}{2\pi} \int_0^{2\pi} X(e^{j\omega}) Y(e^{-j\omega}) d\omega$$

(rounded off to one decimal place) is _____

Ans. 8

Sol.

$$x[n] = 2^{n-1} \cdot U[-n + 2] = \begin{cases} 2^{n-1} ; & n \leq 2 \\ 0 ; & n > 2 \end{cases}$$

$$y[n] = 2^{-n+2} \cdot U[n + 1] = \begin{cases} 2^{-n+2} ; & n \geq -1 \\ 0 ; & n < -1 \end{cases}$$

By Parseval's theorem,

$$\begin{aligned} \frac{1}{2\pi} \int_0^{2\pi} X(e^{j\omega}) \cdot Y(e^{-j\omega}) \cdot d\omega &= \sum_{n=-\infty}^{\infty} x[n] \cdot y[n] \\ &= \sum_{n=-1,0,1,2} x[n] \cdot y[n] \\ &= \sum_{n=-1,0,1,2} 2^{n-1} \cdot 2^{-n+2} \\ &= \sum_{n=-1,0,1,2} (2)^{n-1-n+2} \\ &= \sum_{n=-1,0,1,2} 2^1 \\ &= 2 + 2 + 2 + 2 = 8 \end{aligned}$$

50. The autocorrelation function $R_x(\tau)$ of a wide-sense stationary random process $X(t)$ is shown in the figure.

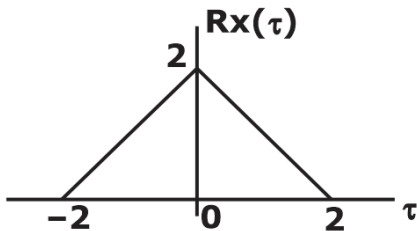

The average of $X(t)$ is _____

Ans. 2

Sol. $E[x(t) \times (t + \tau)] = R_x \times (\tau)$

$$E[x^2(t)] = R_{xx}(0) = 2 \text{ watt}$$

51. An 8-bit unipolar (all analog output values are positive) digital-to-analog converter (DAC) has a full-scale voltage range from 0 V to 7.68 V. If the digital input code is 10010110 (the leftmost bit is MSB). then the Analog output voltage of the DAC (rounded off to one decimal place) is _____ V.

Ans. 4.517

Sol. Analog output volt = Resolution \times Decimal equivalent of binary given

$$= \frac{F.S.C}{2^n - 1} \times \text{Decimal of binary}$$

$$= \frac{7.68}{2^8 - 1} \times 150$$

Decimal equivalent of binary 10010110 $128 + 16 + 4 + 2 = 150$

$$= \frac{7.68}{255} \times 150$$

$$= 4.517$$

52. Consider the circuit shown in the figure

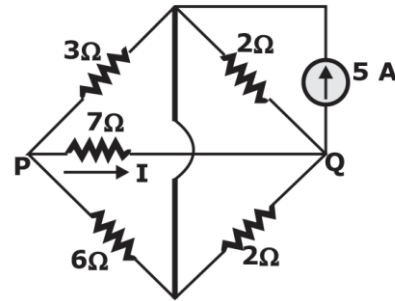

The current I flowing through the 7Ω resistor between P and Q (rounded off to one decimal place) is _____ A.

Ans. 0.5

Sol. Redraw the network,

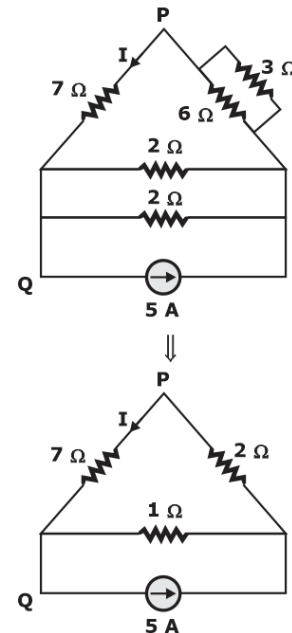

Using current division rule,

$$I = \frac{5 \times 1}{2 + 7 + 1}$$

$$I = 0.5 \text{ A}$$

53. In the circuit shown in the figure, the transistors M_1 and M_2 are operating in

saturation. The channel length modulation coefficients of both the transistors are non-zero. The transconductance of the MOSFETs M_1 and M_2 are g_{m1} and g_{m2} respectively and internal resistance of MOSFETs M_1 and M_2 are r_{o1} and r_{o2} , respectively.

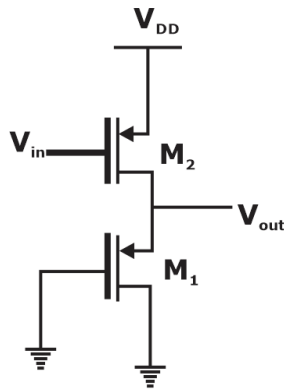

Ignoring the body effect, the ac small signal gain ($\partial V_{out}/\partial V_{in}$) of the circuit is

- A. $-g_{m2}(r_{o1} || r_{o2})$ B. $-g_{m2}(1/g_{m1} || r_{o1} || r_{o2})$
 C. $-g_{m2}(1/g_{m1} || r_{o2})$ D. $-g_{m1}(1/g_{m2} || r_{o1} || r_{o2})$

Ans. B

Sol. $V_0 + (g_{m1}V_0 + g_{m1} + g_{m2}V_{in})(r_{o1} || r_{o2}) = 0$

$$V_0 = -g_{m1}V_0(r_{o1} || r_{o2}) - g_{m2}(r_{o1} || r_{o2})V_{in}$$

$$V_0(1 + g_{m1}(r_{o1} || r_{o2})) = -g_{m2}(r_{o1} || r_{o2})V_{in}$$

$$\frac{\partial V_{out}}{\partial V_{in}} = \frac{-g_{m2}(r_{o1} || r_{o2})}{1 + g_{m1}(r_{o1} || r_{o2})}$$

$$\frac{\partial V_{out}}{\partial V_{in}} = -g_{m2} \left(\frac{1}{g_{m1}} || r_{o1} || r_{o2} \right)$$

54. The propagation delays of the XOR gate, AND gate and multiplexer (MUX) in the circuit shown in the figure are 4ns, 2ns and 1 ns, respectively.

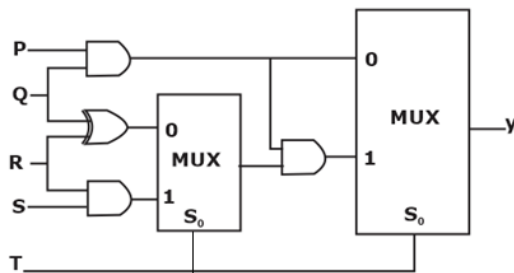

If all the inputs P, Q, R, S and T are applied simultaneously and held constant, the maximum propagation delay of the circuit is

- A. 6 ns B. 3 ns
 C. 5 ns D. 7 ns

Ans. A

Sol. when $S_0 = 0$

$$\text{Then max delay} = 2\text{ns} + 1\text{ns} = 3\text{ns}$$

When $S_0 = 1$

$$\text{Max delay} = 2\text{ns} + 1\text{ns} + 2\text{ns} + 1\text{ns} = 6\text{ns}$$

55. Consider two 16-point sequences $x[n]$ and $h[n]$. Let the linear convolution of $x[n]$ and $h[n]$ be denoted by $y[n]$, while $z[n]$ denotes the 16-point inverse discrete Fourier transform (IDFT) of the product of the 16-point DFTs of $x[n]$ and $h[n]$. The value(s) of k for which $z[k] = y[k]$ is/are

- A. $K = 0$ and $k = 15$ B. $K = 0$
 C. $K = 0, 1, \dots, 15$ D. $K = 15$

Ans. D

Sol. Given

1. $x[n]$ & $h[n]$ are 16-point sequences

$$2. y[n] = x[n] * h[n]$$

$$3. z[n] = \text{I.D.F.T.} \{x[k] H[k]\}$$

Where,

$$X[k] = \text{DFT} \{x[n]\}$$

$$\& H[k] = \text{DFT} \{h[n]\}$$

$$y[n] = x[n] * h[n]$$

$$\text{length of } y[n] = L + M - 1 = 16 + 16 - 1 = 31$$

$$\text{now, } z[n] = \text{IDFT} \{X[k] \cdot H[k]\}$$

$$\Rightarrow z[n] \xleftarrow{\text{DFT}} X[k] H[k]$$

$$\Rightarrow z[n] = \text{circular convolution of } x[n] \& h[n]$$

$$\text{Length} \{y[n]\} = 2L - 1 = 2 \times 16 - 1 = 31$$

$$\text{i.e. } y_0, y_1, \dots, y_{30}$$

$$\text{length} \{z[n]\} = L = 16$$

$$z_0, z_1, \dots, z_{15}$$

$$Z_0 = y_0 + y_{16}$$

$$Z_1 = y_1 + y_{17}$$

$$Z_2 = y_2 + y_{18}$$

$$Z_3 = y_3 + y_{19}$$

$$Z_4 = y_4 + y_{20}$$

$$Z_5 = y_5 + y_{21}$$

$$Z_6 = y_6 + y_{22}$$

$$Z_7 = y_7 + y_{23}$$

$$Z_8 = y_8 + y_{24}$$

$$Z_9 = y_9 + y_{25}$$

$$Z_{10} = y_{10} + y_{26}$$

$$Z_{11} = y_{11} + y_{27}$$

$$Z_{12} = y_{12} + y_{28}$$

$$Z_{13} = y_{13} + y_{29}$$

$$Z_{14} = y_{14} + y_{30}$$

$$Z_{15} = y_{15}$$

$$z(k) = y(k)$$

at $k = 15$

Benefits of Online Classroom Program

1. GATE Learning Tablet

- › Access high-quality classes at your convenience, anywhere and anytime with the tablet

2. Live Classroom Sessions

- › Get Access to Live Classes By India's Leading GATE Faculty

3. Previous Year Question Books

- › 20+ Years PYQs with Solutions

4. Workbooks

- › Access to 3000+ Practice Questions with solutions

5. Regular Quizzes

- › Sample Quizzes for daily practice and regular tests along with live class

6. Doubt Resolution

- › Complete Doubt Resolution within 24 hours by Subject Experts

Additional Offerings

- › **Test Series** - Mock Tests based on GATE Exam pattern
- › **Preparation Guidance** - Get a competitive advantage from our Experts
- › **Subject wise formula Notes** - Comprehensive short notes for Revision
- › **Report Card** - Regular performance analysis along with Live Class

