

# GATE 2020

## Set-1

Mechanical Engineering

Questions



**SECTION: GENERAL APTITUDE**

- Select the word that fits the analogy:  
Build:Building :: Grow : \_\_\_\_\_  
A. Grown  
B. Growed  
C. Grew  
D. Growth
- He is known for his unscrupulous ways. He always sheds..... tears to deceive people.  
A. crocodile's      B. fox's  
C. fox                D. crocodile
- I do not think know the case will enough to have opinions. Having said, I agree with your other point.  
What does the phrase "having said that" mean in the given text?  
A. in addition to what I have said  
B. despite what I have said  
C. contrary to what I have said  
D. as opposed to what I have said
- Jofra Archer, the England fast bowler, is\_\_\_\_\_ than accurate.  
A. less fast  
B. more faster  
C. more fast  
D. faster
- Define  $[x]$  as the greatest integer less than or equal to  $x$ , for each  $x \in (-\infty, \infty)$ , If  $y = [x]$ , then area under  $y$  for  $x \in [1,4]$  is  
A. 1                    B. 3  
C. 4                    D. 6
- The bar graph shows the data of the students who appeared and passed rates (in percentage) of these four schools P, Q, R and S. The average of success rates (in percentage) of these four schools is \_\_\_\_\_.

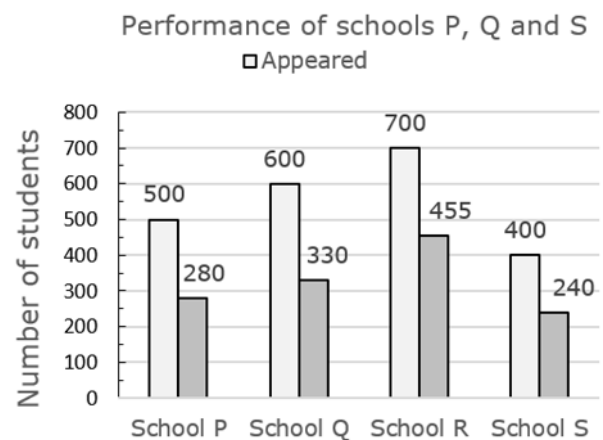
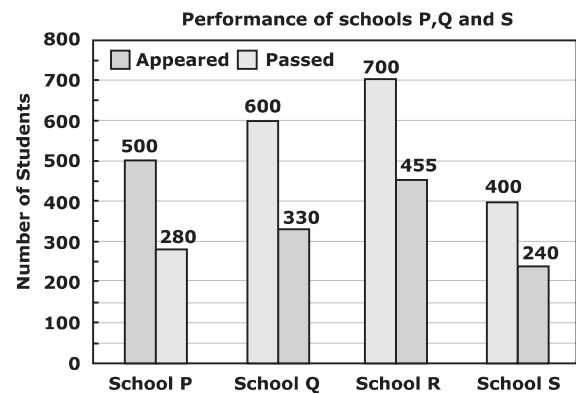

- A. 58.8%                    B. 58.5%  
C. 59.0%                    D. 59.3%

- Crowd funding deals with mobilisation of funds for a project from a large number of people, who would be willing to invest smaller amounts through web-based platforms in the project. Based on the above paragraph, which of the following is correct funding?  
A. Funds raised through unwilling contributions on web-based platforms.  
B. Funds raised through voluntary contributions on web-based platforms.  
C. Funds raised through voluntary contributions on web-based platforms.  
D. Funds raised through large contributions on web-based platforms.

8. P, Q, R and S are to be uniquely coded using  $\alpha$  and  $\beta$ . If P is coded as  $\alpha\alpha$  and Q as  $\alpha\beta$ , then R and S, respectively, can be coded as
- $\alpha\beta$  and  $\beta\beta$
  - $\beta\beta$  and  $\alpha\alpha$
  - $\beta\alpha$  and  $\beta\beta$
  - $\beta\alpha$  and  $\alpha\beta$
9. The sum of the first  $n$  terms in the sequence 8, 88, 888, 8888, ... is \_\_\_\_.
- $\frac{81}{80}(10^n - 1) + \frac{9}{8}n$
  - $\frac{80}{81}(10^n - 1) + \frac{8}{9}n$
  - $\frac{80}{81}(10^n - 1) - \frac{8}{9}n$
  - $\frac{81}{80}(10^n - 1) - \frac{9}{8}n$
10. Select the graph that schematically represents BOTH  $y=x^m$  and  $y=x^{1/m}$  properly in the interval  $0 \leq x \leq 1$ , for integer values of  $m$ , where  $m > 1$ .

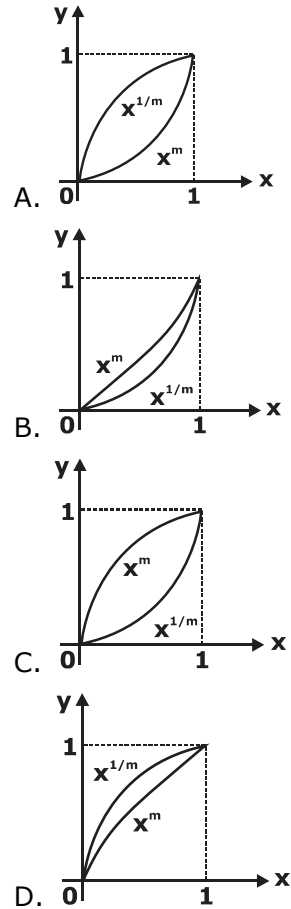

## MECHANICAL ENGINEERING

- 11.** The velocity field of an incompressible flow in a Cartesian system is represented by

$$\vec{V} = 2(x^2 - y^2)\hat{i} + v\hat{j} + 3\hat{k}$$

Which one of the following expressions for  $v$  is valid?

- A.  $4xy + 4xz$       B.  $-4xz + 6xy$   
 C.  $-4xy - 4xz$       D.  $4xz - 6xy$
- 12.** A sheet metal with a stock hardness of 250 HRC has to be sheared using a punch and a die having a clearance of 1 mm between them. If the stock hardness of the sheet metal increases to 400 HRC, the clearance between the punch and the die should be \_\_\_\_\_ mm.

- 13.** For an ideal gas, the value of the Joule-Thomson coefficient is

- A. zero                      B. indeterminate  
 C. negative                 D. positive

- 14.** The compressor of a gas turbine plant, operating on an ideal intercooled Brayton cycle accomplishes an overall compression ratio of 6 in a two-stage compression process. Intercooling is used to cool the air coming out from the first stage to the inlet temperature of the first stage, before its entry to the second stage. Air enters the compressor at 300 K and 100 kPa. If the properties of gas are constant, the intercooling pressure for minimum compressor work \_\_\_\_\_ kPa (round off to 2 decimal places).

- 15.** For three vectors

$\vec{A} = 2\hat{j} - 3\hat{k}$ ,  $\vec{B} = -2\hat{i} + \hat{k}$  and  $\vec{C} = 3\hat{i} - \hat{j}$ , where  $\hat{i}$ ,  $\hat{j}$  and  $\hat{k}$  are unit vectors along the axes of a right-handed rectangular/Cartesian coordinate system, the value of  $(\vec{A} \cdot (\vec{B} \times \vec{C}) + 6)$  is \_\_\_\_\_.

- 16.** Match the following non-dimensional numbers with the corresponding definitions:

Non-dimensional number		Definition	
P	Reynolds number	1	$\frac{\text{Buoyancy force}}{\text{Viscous force}}$
Q	Grashof number	2	$\frac{\text{Momentum diffusivity}}{\text{Thermal diffusivity}}$
R	Nusselt number	3	$\frac{\text{Inertial force}}{\text{Viscous force}}$
S	Prandtl number	4	$\frac{\text{Convective heat transfer}}{\text{Conduction heat transfer}}$

A. P-3, Q-1, R-2, S-4

B. P-4, Q-3, R-1, S-2

C. P-3, Q-1, R-4, S-2

D. P-1, Q-3, R-2, S-4

- 17.** For an ideal gas, a constant pressure line and a constant volume line intersect at a point, in the temperature (T) versus specific entropy (s) diagram.  $C_p$  is the specific heat at constant pressure and  $C_v$  is the specific heat at constant volume. The ratio of the slopes of the constant pressure and constant volume lines at the point of intersection is

A.  $\frac{C_v}{C_p}$                       B.  $\frac{C_p}{C_v}$

C.  $\frac{C_p - C_v}{C_v}$                       D.  $\frac{C_p - C_v}{C_p}$

- 18.** The crystal of  $\gamma$  iron (austenite phase) is

A. HCP                              B. BCT

C. FCC                              D. BCC

- 19.** A helical gear with  $20^\circ$  pressure angle and  $30^\circ$  helix angle mounted at the mid-span of a shaft that is supported between two bearings at the ends. The nature of the stresses induced in the shaft is

- A. normal stress due to bending in two planes; shear stress due to torsion  
 B. normal stress due to bending in one plane and axial loading; shear stress due to torsion  
 C. normal stress due to bending only  
 D. normal stress due to bending in two planes and axial loading; shear stress due to torsion
- 20.** Which of the following function  $f(z)$ , of the complex variable  $z$ , is NOT analytic at all the points of the complex plane?  
 A.  $f(z) = e^z$                       B.  $f(z) = \sin z$   
 C.  $f(z) = \log z$                       D.  $f(z) = z^2$
- 21.** The value of  $\lim_{x \rightarrow 1} \left( \frac{1 - e^{-c(1-x)}}{1 - x e^{-c(1-x)}} \right)$  is  
 A.  $c + 1$                                   B.  $c$   
 C.  $\frac{c+1}{c}$                                       D.  $\frac{c}{c+1}$
- 22.** In the Critical Path Method (CPM), the cost-time slope of an activity is given by  
 A.  $\frac{\text{Normal Cost}}{\text{Crash Time} - \text{Normal Time}}$   
 B.  $\frac{\text{Crash Cost} - \text{Normal Cost}}{\text{Crash Time}}$   
 C.  $\frac{\text{Crash Cost} - \text{Normal Cost}}{\text{Normal Time} - \text{Crash Time}}$   
 D.  $\frac{\text{Crash Cost}}{\text{Crash Time} - \text{Normal Time}}$
- 23.** In a concentric tube counter-flow heat exchanger, hot oil enters at  $102^\circ\text{C}$  and leaves at  $65^\circ\text{C}$ . Cold water enters at  $25^\circ\text{C}$  and leaves at  $42^\circ\text{C}$ . The log mean temperature difference (LMTD) is \_\_\_\_\_  $^\circ\text{C}$  (round off to one decimal place).
- 24.** Froude number is the ratio of  
 A. buoyancy forces to viscous forces  
 B. inertia forces to viscous forces  
 C. inertia forces to gravity forces  
 D. buoyancy forces to inertia forces

- 25.** A single-degree-of-freedom oscillator is subjected to harmonic excitation  $F(t) = F_0 \cos(\omega t)$  as shown in the figure.

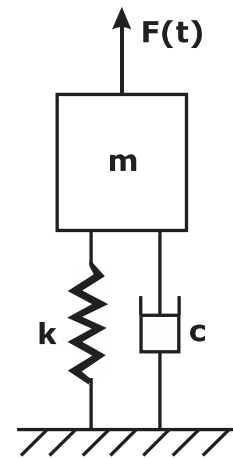

The non-zero value of  $\omega$ , for which the amplitude of the force transmitted to the ground will be  $F_0$ , is

- A.  $2\sqrt{\frac{k}{m}}$                                   B.  $\sqrt{\frac{2k}{m}}$   
 C.  $\sqrt{\frac{k}{m}}$                                       D.  $\sqrt{\frac{k}{2m}}$
- 26.** Match the following.
- | Heat treatment process | Effect           |
|------------------------|------------------|
| P: Tempering           | A. Strengthening |
| Q: Quenching           | B. Toughening    |
| R: Annealing           | C. Hardening     |
| S: Normalizing         | D. Softening     |
- A. P-4, Q-3, R-2, S-1  
 B. P-3, Q-3, R-1, S-3  
 C. P-1, Q-1, R-3, S-2  
 D. P-2, Q-3, R-4, S-1
- 27.** A balanced rigid disc mounted on a rigid rotor has four identical point masses, each of 10 grams, attached to four points on the 100 mm radius circle shown in the figure.

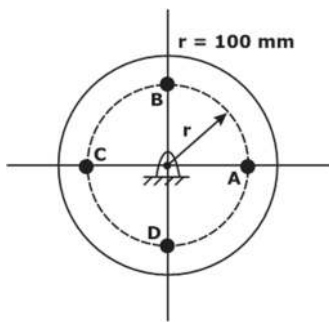

The rotor is driven by a motor at uniform angular speed of 10 rad/s. If one of the masses gets detached then the magnitude of the resultant unbalance force on the rotor is \_\_\_\_\_ N (round off to 2 decimal places).

28. The Laplace transform of a function  $f(t)$  is  $L(f)$

$$= \frac{1}{(s^2 + \omega^2)}. \text{ Then, } f(t) \text{ is}$$

A.  $f(t) = \frac{1}{\omega^2}(1 - \sin \omega t)$

B.  $f(t) = \frac{1}{\omega^2}(1 - \cos \omega t)$

C.  $f(t) = \frac{1}{\omega} \cos \omega t$

D.  $f(t) = \frac{1}{\omega} \sin \omega t$

29. Multiplication of real valued square matrices of same dimension is

- A. always positive definite
- B. not always possible to compute
- C. commutative
- D. associative

30. The stress state at a point in a material under plane stress condition is equi-biaxial tension with a magnitude of 10 MPa. If one unit on the  $\sigma - \tau$  plane is 1 MPa, the Mohr's circle representation of the state-of-stress is given by

- A. a point on the  $\tau$  axis at a distance of 10 units from the origin
- B. a point on the  $\sigma$  axis at a distance of 10 units from the origin
- C. a circle with a radius equal to principal stress and its centre at the origin of the  $\sigma - \tau$  plane
- D. a circle with a radius of 10 units on the  $\sigma - \tau$  plane

31. A company is hiring to fill four managerial vacancies. The candidates are five men and three women. If every candidate is equally likely to be chosen then the probability that at least one woman will be selected is \_\_\_\_\_ (round off to 2 decimal places).

32. A flywheel is attached to an engine to keep its rotational speed between 100 rad/s and 110 rad/s. If the energy fluctuation in the flywheel between these two speeds is 0.05 kJ then the moment of inertia of the flywheel is \_\_\_\_\_  $\text{kg.m}^2$  (round off to 2 decimal places).

33. A four bar mechanism is shown below.

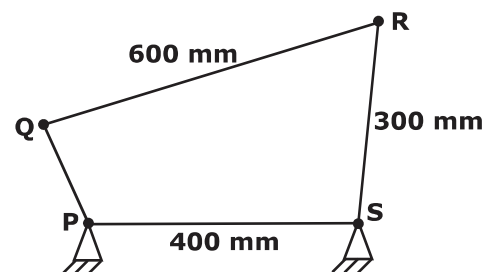

For the mechanism to be a crank-rocker mechanism, the length of the link PQ can be

- A. 300 mm
- B. 200 mm
- C. 350 mm
- D. 80 mm

34. The members carrying zero force (i.e. zero-force members) in the truss shown in the figure, for any load  $P > 0$  with no appreciable deformation of the truss (i.e. with no

appreciable change in angles between the members), are

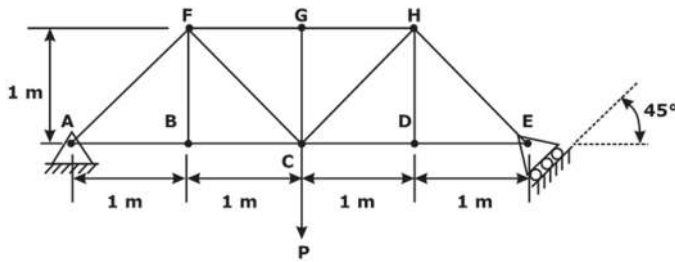

- A. BF, DH, GC, FG and GH only
- B. BF, DH and GC only
- C. BF, DH, GC, CD and DE only
- D. BF and DH only

35. The base of a brass bracket needs rough grinding. For this purpose, the most suitable grinding wheel grade specification is

- A. A50G8V                      B. A30D12V
- C. C90J4B                      D. C30Q12V

36. A small metal bead (radius 0.5 mm), initially at 100°C, when placed in a stream of fluid at 20°C, attains a temperature of 28°C in 0.35 seconds. The density and specific heat of the metal are 8500 kg/m<sup>3</sup> and 400 J/kg.K, respectively. If the bead is considered as lumped system, the convective heat transfer coefficient (in W/m<sup>2</sup>.K) between the metal bead and the fluid stream is

- A. 149.9                      B. 299.8
- C. 449.7                      D. 283.3

37. A slot of 25 mm × 25 mm is to be milled in a workpiece of 300 mm length using a side and face milling cutter of diameter 100 mm, width 25 mm and having 20 teeth.

For a depth of cut 5 mm, feed per tooth 0.1 mm, cutting speed 35 m/min and approach and over travel distance of 5 mm each, the time required for milling the slot is \_\_\_\_\_ minutes (round off to one decimal place).

38. A rectangular steel bar of length 500 mm, width 100 mm, and thickness 15 mm is cantilevered to a 200 mm steel channel using 4 bolts, as shown.

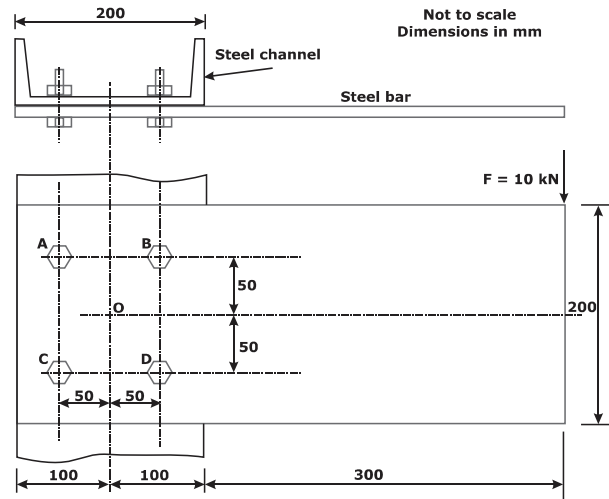

For an external load of 10 kN applied at the tip of the steel bar, the resultant shear load on the bolt at B, is \_\_\_\_\_ kN (round off to one decimal place).

39. The truss shown in the figure has four members of length  $l$  and flexural rigidity  $EI$ , and one member of length  $l\sqrt{2}$  and flexural rigidity  $4EI$ . The truss is loaded by a pair of forces of magnitude  $P$ , as shown in the figure.

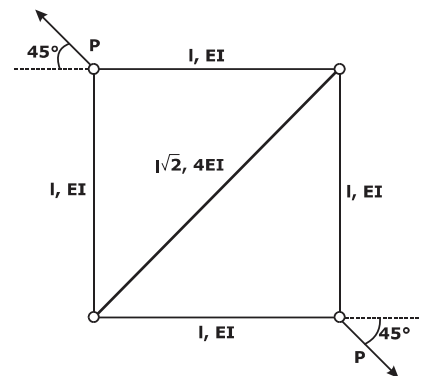

The smallest value of  $P$ , at which any of the truss members will buckle is

- A.  $\frac{2\pi^2 EI}{l^2}$                       B.  $\frac{\pi^2 EI}{2l^2}$
- C.  $\frac{\sqrt{2}\pi^2 EI}{l^2}$                       D.  $\frac{\pi^2 EI}{l^2}$

40. Bars of square and circular cross-section with 0.5 m length are made of a material with shear strength of 20 MPa. The square bar cross-section dimension is 4 cm × 4 cm and the cylindrical bar cross-section diameter is 4 cm. The specimens are loaded as shown in the figure.

Which specimen(s) will fail due to the applied load as per maximum shear stress theory?

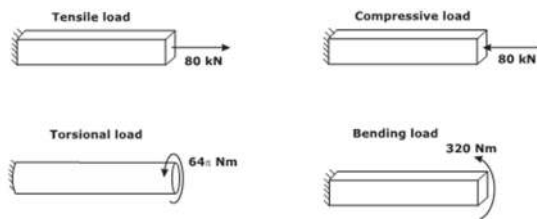

- A. None of the specimens  
 B. Tensile and compressive load specimens  
 C. Bending load specimen  
 D. Torsional load specimen
41. A strip of thickness 40 mm is to be rolled to a thickness of 20 mm using a two-high mill having rolls of diameter 200 mm. Coefficient of friction and arc length in mm, respectively are
- A. 0.39 and 44.72  
 B. 0.45 and 4D.72  
 C. 0.45 and 38.84  
 D. 0.39 and 38.84
42. An analytic function of a complex variable  $z = x + iy$  ( $i = \sqrt{-1}$ ) is defined as
- $$f(z) = x^2 - y^2 + i\psi(x, y),$$
- where  $\psi(x, y)$  is a real function. The value of the imaginary part of  $f(z)$  at  $z = (1 + i)$  is \_\_\_\_\_ (round off to 2 decimal places).
43. A rigid mass-less rod of length  $L$  is connected to a disc (pulley) of mass  $m$  and radius  $r = L/4$  through a friction-less revolute joint. The other end of that rod is attached to a wall through a

friction-less hinge. A spring of stiffness  $2k$  is attached to the rod at its mid-span. An inextensible rope passes over half the disc periphery and is securely tied to a spring of stiffness  $k$  at point  $C$  as shown in the figure. There is no slip between the rope and the pulley. The system is in static equilibrium in the configuration shown in the figure and the rope is always taut.

Neglecting the influence of gravity, the natural frequency of the system for small amplitude vibration is

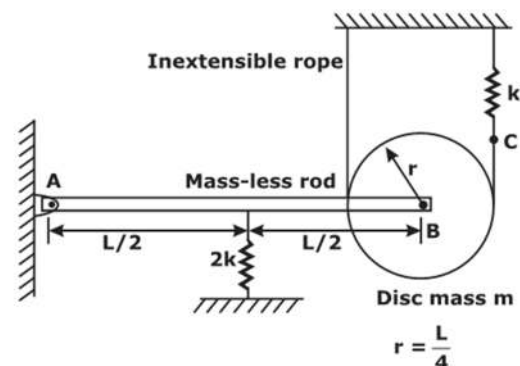

- A.  $\sqrt{\frac{k}{m}}$       B.  $\frac{3}{\sqrt{2}} \sqrt{\frac{k}{m}}$   
 C.  $\sqrt{3} \sqrt{\frac{k}{m}}$       D.  $\sqrt{\frac{3}{2}} \sqrt{\frac{k}{m}}$
44. In a turning process using orthogonal tool geometry, a chip length of 100 mm is obtained for an uncut chip length of 250 mm. The cutting conditions are: cutting speed = 30 m/min, rake angle =  $20^\circ$ . The shear plane angle is \_\_\_\_\_ degrees (round off to one decimal place).
45. For an ideal Rankine cycle operating between pressures of 30 bar and 0.04 bar, the work output from the turbine is 903 kJ/kg and the work input to the feed pump is 3 kJ/kg. The specific steam consumption is \_\_\_\_\_ kg/kW.h (round off to 2 decimal places).



**46.** The following data applies to basic shaft system:

tolerance for hole = 0.002 mm,  
tolerance for shaft = 0.001 mm,  
allowance = 0.003 mm,  
basic size = 50 mm.

The maximum hole size is \_\_\_\_ mm (round off to 3 decimal places).

**47.** Consider two exponentially distributed random variables X and Y, both having a mean of 0.50. Let  $Z = X + Y$  and r be the correlation coefficient between X and Y. If the variance of Z equals 0, then the value of r is \_\_\_\_ (round off to 2 decimal places).

**48.** A vector field is defined as

$$\vec{f}(x, y, z) = \frac{x}{[x^2 + y^2 + z^2]^{\frac{3}{2}}} \hat{i} + \frac{y}{[x^2 + y^2 + z^2]^{\frac{3}{2}}} \hat{j} + \frac{z}{[x^2 + y^2 + z^2]^{\frac{3}{2}}} \hat{k}$$

where,  $\hat{i}, \hat{j}, \hat{k}$  are unit vectors along the axes of a right-handed rectangular/Cartesian

coordinate system. The surface integral  $\iint \vec{f} \cdot d\vec{S}$

(where  $d\vec{S}$  is an elemental surface area vector) evaluated over the inner and outer surfaces of a spherical shell formed by two concentric spheres with origin as the center, and internal and external radii of 1 and 2, respectively, is

- A.  $2\pi$
- B. 0
- C.  $4\pi$
- D.  $8\pi$

**49.** Air discharges steadily through a horizontal nozzle and impinges on a stationary vertical plate as shown in figure.

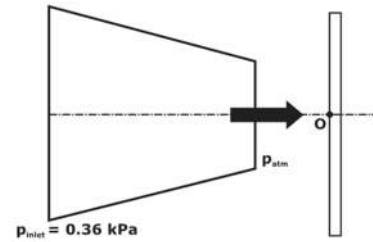

The inlet and outlet areas of the nozzle are  $0.1 \text{ m}^2$  and  $0.02 \text{ m}^2$ , respectively. Take air density as constant and equal to  $1.2 \text{ kg/m}^3$ . If the inlet gauge pressure of air is 0.36 kPa, the gauge pressure at point O on the plate is \_\_\_\_ kPa (round off to two decimal places).

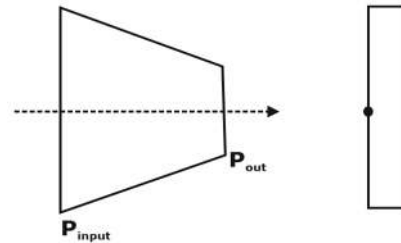

**50.** The evaluation of the definite integral  $\int_{-1}^{1.4} x|x| dx$  by using Simpson's  $1/3^{\text{rd}}$  (one-third) rule with step size  $h = 0.6$  yields

- A. 0.592
- B. 0.581
- C. 1.248
- D. 0.914

**51.** For assembly line, the production rate was 4 pieces per hour and the average processing time was 60 minutes. The WIP inventory was calculated. Now, the production rate is kept the same, and the average processing time is brought down by 30 percent. As a result of this change in the processing time, the WIP inventory

- A. decreases by 30%
- B. increases by 30%
- C. increases by 25%
- D. decreases by 25%

**52.** Consider steady, viscous, fully developed flow of a fluid through a circular pipe of internal diameter D. We know that the velocity profile

forms a paraboloid about the pipe centre line, given by :  $V = -C(r^2 - \frac{D^2}{4})$  m/s, where C is constant. The rate of kinetic energy (in J/s) at the control surface A - B, as shown in the figure, is proportional to  $D^n$ , The value of n is

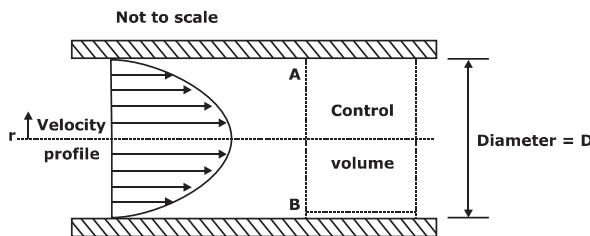

- 53.** In a disc-type axial clutch, the frictional contact takes place within an annular region with outer and inner diameters 250 mm and 50 mm, respectively. An axial force  $F_1$  is needed to transmit a torque by a new clutch. However, to transmit the same torque, one needs an axial force  $F_2$  when the clutch wears out. If contact pressure remains uniform during operation of a new clutch while the wear is assumed to be uniform for an old clutch, and the coefficient of friction does not change, then the ratio  $F_1/F_2$  is (round off to 2 decimal places).
- 54.** For a Kaplan (axial flow) turbine, the outlet blade velocity diagram at a section is shown in

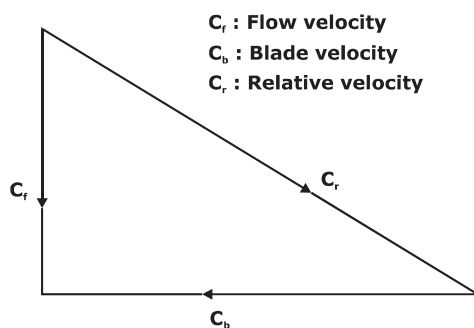

figure.

The diameter at this section is 3 m. The hub and tip diameters of the blade are 2 m and 4 m respectively. The water volume flow rate is  $100 \text{ m}^3/\text{s}$ . The rotational speed of the turbine is 300

rpm. The blade outlet angle  $\beta$  is \_\_\_\_\_ degrees (round off to one decimal place).

- 55.** A steel part with surface area of  $125 \text{ cm}^2$  is to be chrome coated through an electroplating process using chromium acid sulphate as an electrolyte. An increasing current is applied to the part according to the following current time relation:

$$I = 12 + 0.2t$$

where  $I$  = current A. and  $t$  = time (minutes).

The part is submerged in the plating solution for duration of 20 minutes for plating purpose. Assuming the cathode efficiency of chromium to be 15% and the plating constant of chromium acid sulphate to be  $2.50 \times 10^{-2} \text{ mm/A-s}$ , the resulting coating thickness on the part surface is \_\_\_\_\_  $\mu\text{m}$  (round off to one decimal place).

- 56.** A cam with a translating flat-face follower is desired to have the follower motion

$$Y(\theta) = 4 [2\pi\theta - \theta^2], \quad 0 \leq \theta \leq 2\pi$$

Contact stress consideration dictate that the radius of curvature of the cam profile should not be less than 40 mm anywhere. The minimum permissible basic circle radius in mm (round off to one decimal place).

- 57.** The indicated power developed by an engine with compression ratio of 8, is calculated using an air-standard Otto cycle (constant properties). The rate of heat addition is 10kW. The ratio of specific heats at constant pressure and constant volume is 1.4 The mechanical efficiency of the engine is 80 per cent. The brake power output of the engine is \_\_\_\_\_ kW (round off to one decimal place).

- 58.** The 2 kg block shown in figure (top view) rests on a smooth horizontal surface and is attached to a massless elastic cord that has a stiffness 5 N/m.

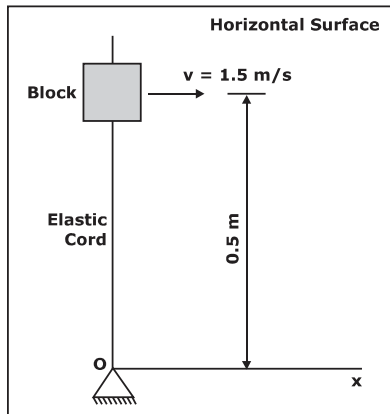

The cord hinged at O is initially unstretched and always remains elastic. The block is given a velocity  $v$  of 1.5 m/s perpendicular to the cord. The magnitude of velocity in m/s of the block at the instant the cord is stretched by 0.4 m is

- A. 1.36                      B. 0.83  
C. 1.50                      D. 1.07
- 59.** Two business owners Shweta and Ashok run their business in two different status. Each of them, independent of the other, produces two products A and B, sells them at 2,000 per kg and 3,000 per kg. respectively, and uses Linear Programming to determine the optimal quantity of A and B to maximize their respective daily revenue. Their constraints are as follows: i) for each business owner, the production process is such that the daily production of A has to be at least as much as B, and the upper limit for production of B is 10 kg per day, and ii) the respective state regulations restrict Shweta's production of A to less than 20kg per day, and Ashok's production of A to less than 15 kg per day. The demand of both A and B in both the states is very high and everything produced is sold.

The absolute value of the difference in daily (optimal) revenue of Shweta and Ashok is thousand Rupees(round off to 2 decimal places).

- 60.** The magnitude of reaction force at joint C of the hinge-beam shown in the figure is \_\_\_\_\_ kN (round off to 2 decimal places).

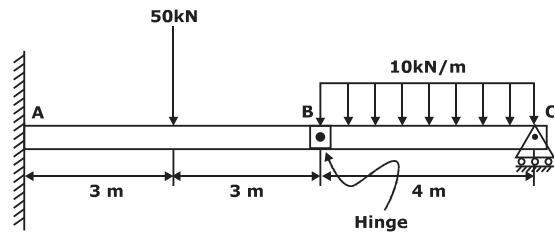

- 61.** One kg of air, initially at a temperature of 127°C, expands reversibly at a constant pressure until the volume is doubled. If the gas constant of air is 287 J/kg.K, the magnitude of work transfer is \_\_\_\_\_ kJ (round off to 2 decimal places).
- 62.** The thickness of a steel plate with material strength coefficient of 210 MPa, has to be reduced from 20 mm to 15 mm in a single pass in a two-high rolling mill with a roll radius of 450 mm and rolling velocity of 28 m/min. If the plate has a width of 200 mm and its strain hardening exponent,  $n$  is 0.25, the rolling force required for the operation is \_\_\_\_\_ kN (round off to 2 decimal places).  
Note: Average Flow Stress = Material Strength Coefficient  $\times \frac{(\text{True Strain})^n}{(1+n)}$
- 63.** Air (ideal gas) enters a perfectly insulated compressor at a temperature of 310 K. The pressure ratio of the compressor is 6. Specific heat at constant pressure for air is 1005 J/kg.K and ratio of specific heats at constant pressure and constant volume is 1.4. Assume that specific heats of air are constant. If the

isentropic efficiency of the compressor is 85 per cent, the difference in enthalpies of air between the exit and the inlet of the compressor is \_\_\_\_\_ kJ/kg (round off to nearest integer).

- 64.** The barrier shown between two water tanks of unit width (1m) into the plane of the screen is modeled as a cantilever.

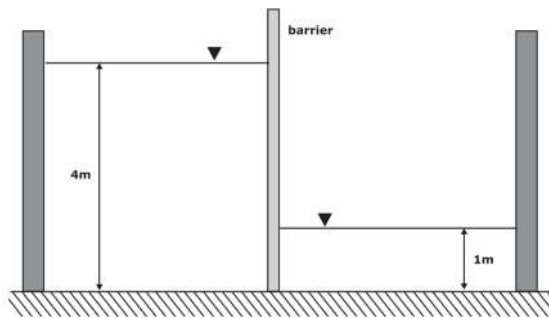

Taking the density of water as  $1000 \text{ kg/m}^3$ , and the acceleration due to gravity as  $10 \text{ m/s}^2$ . The maximum absolute bending moment

developed in the cantilever is \_\_\_\_\_ kN.m (round off to the nearest integer).

- 65.** Consider two cases as below.

Case 1 : A company buys 1000 pieces per year of a certain part from vendor 'X'. The changeover time is 2 hours and the price is Rs. 10 per piece. The holding cost rate per part is 10% per year.

Case 2: For the same part, another vendor 'Y' offers a design where the changeover time is 6 minutes, with a price of Rs. 5 per piece, and holding cost rate per part of 100% per year. The order size is 800 pieces per year from 'X' and 200 pieces per year from 'Y'.

Assume the cost of downtime as Rs. 200 per hour. The percentage reduction in the annual cost for Case 2, as compared to Case 1 is \_\_\_\_\_ (round off to 2 decimal places).

\*\*\*\*

## Benefits of Online Classroom Program

### 1. GATE Learning Tablet

- › Access high-quality classes at your convenience, anywhere and anytime with the tablet

### 2. Live Classroom Sessions

- › Get Access to Live Classes By India's Leading GATE Faculty

### 3. Previous Year Question Books

- › 20+ Years PYQs with Solutions

### 4. Workbooks

- › Access to 3000+ Practice Questions with solutions

### 5. Regular Quizzes

- › Sample Quizzes for daily practice and regular tests along with live class

### 6. Doubt Resolution

- › Complete Doubt Resolution within 24 hours by Subject Experts

## Additional Offerings

- › **Test Series** - Mock Tests based on GATE Exam pattern
- › **Preparation Guidance** - Get a competitive advantage from our Experts
- › **Subject wise formula Notes** - Comprehensive short notes for Revision
- › **Report Card** - Regular performance analysis along with Live Class

