

MATHEMATICS

Class-10



2021-22

State Council of Educational Research and Training Chhattisgarh, Raipur

For Free Distribution

- Publication Year** : 2021
- © Director, SCERT Chhattisgarh, Raipur
- Guide** : Prof. Hridaykant Diwan, Azim Premji University, Bangalore
- Colaboration** : VBERC Udaypur, Azim Premji Foundation
- Convener** : Dr. Vidyawati Chandrakar, Assistant Professor, SCERT Chhattisgarh, Raipur
- Subject Coordinator** : Dr. Sudhir Shrivastava, Assistant Professor, SCERT Chhattisgarh, Raipur
- Writers** : Dr. Sudhir Shrivastava, T.K. Gajpal, Nand Lal Shah, Dr. Raghvendra Gauraha, Harendra Singh Bhuwal, Sirish Kumar Nande, Khan Waquaruzman Khan, Arti Mane, Dr. Ritu Shrivastava, Tanya Saxena, Neha Kashyap, Ramkumar Sahu, Brij Lal Patel
- Translation** : Vidya Bhavan Educational Resource Center, Udaypur
- Cover Page and Layout Designing** : Rekhraj Chouragadey
- Typing** : Ikram Shekh, Sakir
- Illustration** : Prashant Soni, Vidya Bhavan Educational Resource Center, Udaypur

Published by

State Council of Educational Research & Training Chhattisgarh, Raipur

Printed by

Chhattisgarh Textbook Corporation, Raipur

Printing Press

.....

Note for Teachers.....

You would have taught the class nine book by now and experienced the nuances of this book. You would have also noticed that the confidence in children has increased and they are now able to solve problems better. You would have also noticed that children can read the book and attempt to understand and solve problems on their own. They may not always succeed but they have greater confidence and desire to make the effort themselves. This is a great success facilitated by the manner you have used the book. You would have also seen that the discussions they have amongst themselves have improved and they are now able to listen to each other and make useful points. We are also sure that you would have noticed that you have a better understanding of what they are doing when you move around as they are working in groups. It would have helped you to recognise the areas that they are having difficulty with and support them in learning. These practices would need to be continued in class X and in fact intensified as students will now be more confident of working in groups, reading the book themselves, attempting to solve the questions below the form of 'Try these' and the exercises in the book. Class X is also an important because it is the year children would have the board exam. The board exams for this book would follow the pattern that has been emphasised. It will not for example have questions that are largely from the exercises itself.

In this book, there is emphasis on the ways of verifying mathematical statements so that students may prove mathematical statements instead of accepting it obviously, understand the logic behind it and understand difference between proof and verification. So you give opportunities in the classrooms to the students to write new statements and to find their own way to prove it or to understand the previous theorems by reading them.

In secondary level it is expected that student can read mathematical language, can make new mathematical statements by using their signs and symbols. More opportunities are there in this book where they will find answers by inferring the mathematical statements. By keeping this facts in mind in this

book several new symbols have been introduced and along with generalisation is emphasized. More practice is necessary for this.

Conceptual and procedural knowledge are linked in the chapters like geometry, ratio proportions, banking and taxation. There is emphasis on making procedures purposeful and meaningful example: in coordinate geometry.

There are strong linkages within the chapters like similarity, ratio proportion and height-distances; graphs with one variable and two variable equations.

Chapters like Mensuration are not written just as formula based chapters. Use of net to understand/find out meaning of S.A, volume. So teachers can encourage students to draw nets and explore. Here the nets on cube and cuboid are included.

We hope that you and children will enjoy the problems and activities which is given in the book. Share your experiences and make change in questions of the book, this is necessary to keep it alive so give new problems to students and send it to us also so that we may add it in next edition. Your suggestions and questions will help us to make textbook more better.

Director

State Council Of Educational Research
And Training Chhattisgarh, Raipur

Syllabus

Class-10 ,Subject- Mathematics

External Evaluation-75 Marks

Internal Evaluation-25

Unit -1 Algebra

Chapter-1 Polynomials

Division of Polynomials, Remainder Theorem, Factor Theorem, Factoring of Polynomials, Factoring of Polynomials of form by splitting middle term, Value and zero of quadratic Polynomials, Relation between coefficient and zero of Polynomials

Chapter-2 Linear Equations In Two Variables

Making equations from statements, Solution of Simultaneous equations-Graphical Method, Elimination, Substitution, Finding types of solution by Inspection, Finding value of unknown coefficient of variables, Making statement from equations.

Chapter-3 Quadratic Equations In One Variable

Quadratic equations, Roots of equations, Verification of roots, Methods of solving quadratic equations- by factoring, by making complete square, by formula, Discriminant of Quadratic equations, Nature of roots, Finding coefficient constant of quadratic equations, relation between roots and coefficient of quadratic equations, Making quadratic equations using roots.

Chapter-4 Arithmetic Progression

Arithmetic Progression, n-th term of arithmetic progression, Arithmetic Mean of two quantities, Making arithmetic progression between two quantities, Sum of n-th term of arithmetic progression.

Chapter-5 Ratio And Proportion

Ratio, Use of ratio in behaviour, distributing two or more parts, distributing any quantity in any ratio, Proportion, middle, ratio, fourth ratio, third ratio, continuous ratio, K-Rule, Inverse ratio.

Unit -2 Coordinate Geometry

Chapter-6 Coordinate Geometry

Introduction to Cartesian coordinates, Presentation of a point on a plane, Finding distance between two points, Slope of interval, Slope of line, Intercepts of line on axes, equation of lines in form of gradient and intercept.

Chapter-7 Graph

Looking relations between two quantities in graph, Graphical representation of relations between two quantities, Reading and making decision of graphs of different context.

Unit -3 Commercial Mathematics

Chapter-8 Banking and Taxation

Banking, Calculation of interest on Recurring deposit, Calculation of interest on fixed deposit, Income tax, calculation of income tax.

Unit -4 Trigonometry

Chapter-9 Trigonometrical equations and Identities

Relation between trigonometrical ratio, Expressing in a trigonometrical ratio taking all trigonometrical ratios, Trigonometrical identities, equations with solutions trigonometrical ratio of supplementary angles.

Chapter-10 Height And Distance

Angle of Elevation, Angle of Depression, Exercises based on height and distance.

Unit -5 Geometry

Chapter-11 Similarity in Geometrical Shapes

Scaling, Test of similarity in different geometrical shapes, Theorem on similarity.

Chapter-12 Circles And Tangents

Chord, Arc, Sector, Segment, Congruent circle, Theorems, Tangents of circle , Theorems

Chapter-13 Geometrical Constructions

Construction of Similar Polygons, Construction of Similar quadrilateral, Construction of incircle and circumcircle.

Unit -6 Proof Of Mathematical Statements

Chapter-14 Proof of Mathematical Statements

Basics of proving Mathematical Statements, Proof by Deductive Logistics, Use of Mathematical Language in proving statements, Methods for proving statements.

Unit -7 Mensuration

Chapter-15 Surface Area and Volume of Solid Shapes

Surface Net of Cube and Cuboid, Diagonal of Cube and Cuboid, Surface Area and Volume of Cylinder, Surface Area and Volume of Cone, Surface Area and Volume of Spheres

Unit -8 Statistics

Chapter-16 Data Analysis

Analysis of Data of Graphs, Arithmetic Average, Median, Mode and understanding of its uses, Interpolation and Extrapolation.

CONTENT

Unit	Name of Unit	Chapter	Page No.
1.	Algebra	1. Polynomials	01-28
		2. Linear Equation in two variables	29-64
		3. Quadratic Equation in one variables	65-98
		4. Arithmetic Progression	99-124
		5. Ratio and Proportion	125-142
2.	Co-Ordinate Geometry	6. Co-Ordinate Geometry	143-166
		7. Graph	167-182
3.	Commercial Mathematics	8. Banking and Taxation	183-198
4.	Trigonometry	9. Trigonometric Equations and Identities	199-220
		10. Height and Distance: Trigonometrical Applications	221-234
5.	Geometry	11. Similarity in Geometrical Shapes	235-262
		12. Circle and Tangents	263-302
		13. Geometrical Constructions	303-322
6.	Proof of Mathematical Statements	14. Proof of Mathematical Statements	323-342
7.	Mensuration	15. Surface Area And Volume of Solids	343-366
8.	Statistics	16. Data Analysis	367-400

POLYNOMIALS

CHAPTER

01

Introduction

In the expressions $3x^2 + 7x - 2$, $x^2 - \frac{1}{2}x + 3$ and $y^3 - \sqrt{2}y^2 + 3y - 7$ the exponents of each of the variables (expressed in letters) are whole numbers. These type of expressions are known as polynomials. You have learnt addition, subtraction and multiplication of polynomials in Class-IX. Let us consider the operations of addition, subtraction and multiplication once again.

1. Add $x+3$ and $x+4$

Solution: Addition of $(x+3)$ and $(x+4)$ i.e.

$$\begin{aligned}(x+3) + (x+4) \\ &= x+3 + x+4 \\ &= (x+x) + (3+4) \\ &= 2x+7\end{aligned}$$

2. Subtract $x^2 + x - 2$ from the polynomial $2x^2 + 3x + 5$

Solution: Subtract $x^2 + x - 2$ from $2x^2 + 3x + 5$ i.e.

$$\begin{aligned}(2x^2 + 3x + 5) - (x^2 + x - 2) \\ &= 2x^2 + 3x + 5 - x^2 - x + 2 \\ &= (2x^2 - x^2) + (3x - x) + (5 + 2) \\ &= x^2 + 2x + 7\end{aligned}$$

3. Multiply $(x+5)$ to $(x-7)$

Solution : Multiply $(x+5)$ to $(x-7)$ i.e.

$$\begin{aligned}(x+5)(x-7) \\ &= x(x-7) + 5(x-7) \\ &= x^2 - 2x - 35\end{aligned}$$



Try These



1. Add the polynomials $2x - 7$ and $5x + 9$.
2. Subtract $x^2 + 3x - 4$ from the polynomial $3x^2 + 2x - 3$.
3. Multiply the polynomials $x^2 + 2x - 3$ and $x^2 + x - 2$.

Can We Divide a Polynomial

Notice that the terms with the same exponent are put together while adding and subtracting. Exponents are added in case of multiplication. We have carried out addition, subtraction and multiplication of polynomials and know how to do these operations.

Can we do division of polynomials in the same way as we do addition, subtraction and multiplication of polynomials? How do we manage terms and exponents during division? Before finding the answer to these questions let us see why we need to divide polynomials.

Look at the situation given below:

1. A car travels a distance of x km in 4 hours. Find the speed of the car.

Solution: Distance travel led by the car = x km

and time taken to travel this distance = 4 hours

$$\therefore \text{Speed} = \frac{\text{Distance}}{\text{Time}}$$

$$\therefore \text{Speed} = \frac{x}{4} \text{ km/hour}$$

This division is easy because it involves division of a polynomial having one term by a polynomial having one constant.

2. If the area of a rectangle is $40x^2$ m² and length of one of its side is $10x$ meter then what is breadth of the rectangle?

Solution: Area of rectangle = $40x^2$ Sq.mt.

Length of rectangle = $10x$ meter

\therefore Area of rectangle = length \times breadth

$$40x^2 = 10x \times \text{breadth}$$

$$\therefore \text{breadth} = \frac{40x^2}{10x}$$

$$= \frac{4 \times 10 \times x \times x}{10x}$$

$$= 4x \text{ meter}$$

Here, quotient and divided both are monomials and remainder is also a monomial.
Now, we divide a binomial polynomial by a monomial.

3. Divide the polynomial $18x^2 + 9x$ by $3x$.

Solution: To divide $18x^2 + 9x$ by $3x$ we can write in the following way:

$$\frac{18x^2}{3x} + \frac{9x}{3x}$$

$$= 6x + 3$$

Try These

1. Divide $2x^3 + 12x + 6$ by $2x$.
2. A bus travels a distance of y km in 5 hours. Find the speed of the bus.
3. Area of a rectangular garden is $65x^2$ square meter and the breadth of that garden is $5x$ meter. Then, find the length of the garden.
4. The length of the base a right angle triangle is $2x$ units and its area is $4x^2 + 4$. Find the length of the perpendicular of the triangle.



The process of division followed in the above examples can also be used to solve practical problems. Let us see some examples.

Example-1. We have a line segment AB whose length is $8x$ units and we have to divide it into two equal parts. How will you tell the length of each part?

Solution: Suppose C is any point on line segment AB which divides AB into two equal parts.

We can write this in the following way:-

$$AB = AC + BC$$

Now, since C divides line segment AB into two equal parts

$$\text{So, } AC = BC$$

$$\therefore AB = AC + AC$$

$$8x = 2AC$$

$$\text{or } AC = \frac{8x}{2}$$

$$AC = \frac{2 \times 4x}{2}$$

$$AC = 4x$$

Hence, the lengths of both equal parts of the line segment are $4x$ units each.

Division by Polynomial with Multiple Terms

While dividing a multiple term polynomial by a one term polynomial, we first write each term separately. Let us see how.

Factorise polynomial $18x^2 + 9x$ and divide it by $3x$.

To divide $18x^2 + 9x$ by $3x$, we can write in the following way:-

$$\begin{aligned} & \frac{18x^2 + 9x}{3x} \\ &= \frac{9 \times 2 \times x \times x + 9 \times x}{3x} \\ &= \frac{9x(2x+1)}{3x} \\ &= 3(2x+1) \\ &= 6x+3 \end{aligned}$$

See one more example

Factorise the polynomial $4x^4 + 12x^3 + 8x^2$ and divide it by $4x^2$

To divide $4x^4 + 12x^3 + 8x^2$ by $4x^2$ we can write in the following way:

$$\begin{aligned} & \frac{4x^4 + 12x^3 + 8x^2}{4x^2} \\ &= \frac{4x^2 \times x^2 + 3x \times 4x^2 + 2 \times 4x^2}{4x^2} \\ &= \frac{4x^2(x^2 + 3x + 2)}{4x^2} \\ &= x^2 + 3x + 2 \end{aligned}$$



Division of a Polynomial by Factorisation

Now we will learn division of a polynomial by factorisation method.

If we have to divide polynomial $2x^2 + 5x - 3$ by $(x - 2)$, then can we apply the above method of division?

To divide $2x^2 + 5x - 3$ by $(x - 2)$ we can write in the following way:-

$$\frac{2x^2 + 5x - 3}{x - 2}$$

But here we cannot find any common factor in numerator and denominator and we cannot determine the quotient. In this situation, we can use long division method of division.

In algebra you know that the meaning of division of 25 by 4 is

$$\frac{25}{4} \text{ i.e.}$$

$$\begin{array}{r|l} \text{Dividend} & \\ \text{Divisor } 4 & 25 \Big| 6 \text{ Quotient} \\ & \underline{-24} \\ & 1 \\ & \text{Remainder} \end{array}$$

Here $25 = 4 \times 6 + 1$

This is the same as

$$\text{Dividend} = \text{Divisor} \times \text{Quotient} + \text{Remainder}$$

Similarly, by dividing dividend by divisor we will get quotient and remainder. The remainder will be zero in the case of complete division.

Example-2. Divide the polynomial $2x^2 + 5x - 3$ by the polynomial $x - 2$.

Solution: Here, polynomial $2x^2 + 5x - 3$ is dividend and $(x - 2)$ is divisor.

$$\begin{array}{r|l} \text{Dividend} & \\ \text{Divisor } (x-2) & 2x^2 + 5x - 3 \Big| 2x + 9 \text{ Quotient} \\ & \underline{-(2x^2 - 4x)} \\ & 9x - 3 \\ & \underline{-(9x - 18)} \\ & +15 \\ & \text{Remainder} \end{array}$$



Here, we found that the quotient is $2x + 9$ and remainder is 15.

So, the process of division is completed using the following steps:-

Step-1. Write the dividend and divisor in the descending order of their degrees.

Step-2. Divide the first term of dividend by the first term of the divisor

$$\text{Here } \frac{2x^2}{x} = 2x$$

This, is the first term of the quotient

Step-3. We will multiply the divisor with this quotient and will subtract the product from dividend

$$\begin{array}{r} (x-2)2x = 2x^2 - 4x \\ 2x^2 + 5x - 3 \\ \underline{-2x^2 + 4x} \\ 9x - 3 \end{array}$$

Step-4. Divide the the first term of result of subtraction by first term of divisor.

$$\text{i.e. } \frac{9x}{x} = 9 \text{ This is the second term of quotient.}$$

Step-5. We will again multiply this quotient with the divisor.

$$\text{i.e. } 9 \times (x-2) = 9x - 18$$

Now we will subtract $9x - 18$ from $9x - 3$.

$$\begin{array}{r} 9x - 3 \quad \text{Or} \quad 9x - 3 \\ \underline{-(9x - 18)} \\ +15 \end{array}$$

We will repeat this process till the remainder becomes zero or the degree of the remainder becomes less than the power of the variables of the divisor. The remainder is 15 in this example and its power is less than the power of the variable in $(2x + 9)$.

Brief representation of this division is:-

$$(2x^2 + 5x - 3) = (x - 2)(2x + 9) + 15$$

$$\text{i.e. Dividend} = \text{Divisor} \times \text{Quotient} + \text{Reminder}$$

Example-3. Divide the polynomial $5x - 11 - 12x^2 + 2x^3$ by the polynomial $x - 5$.

Solution: Here, dividend is $5x - 11 - 12x^2 + 2x^3$ and divisor is $x - 5$.

The power of x in divisor is in descending order and we will also have to write the power of x of dividend in descending order.

When we write the power in descending order, the dividend will be $2x^3 - 12x^2 + 5x - 11$.

Now,

$$(x-5) \left| \begin{array}{r} 2x^3 - 12x^2 + 5x - 11 \\ -(2x^3 - 10x^2) \\ \hline -2x^2 + 5x - 11 \\ -(-2x^2 + 10x) \\ \hline -5x - 11 \\ -(-5x + 25) \\ \hline -36 \end{array} \right| 2x^2 - 2x - 5$$

For $2x^3$ we will take quotient $2x^2$
 Now we will take $-2x$ for $-2x^2$
 Now we will take -5 for $-5x$.
 Now we can't divide any further.
 This is the remainder.

Here, quotient = $2x^2 - 2x - 5$

Remainder = -36

Example-4. Divide the polynomial $2x^3 - 3x^2 - x + 3$ by the polynomial $2x^2 = 4x + 3$.

Solution: Here, dividend is $2x^3 - 3x^2 - x + 3$ and divisor is $2x^2 - 4x + 3$.

$$\text{Now, } 2x^2 - 4x + 3 \left| \begin{array}{r} 2x^3 - 3x^2 - x + 3 \\ -(2x^3 - 4x^2 + 3x) \\ \hline x^2 - 4x + 3 \\ -(x^2 - 2x + \frac{3}{2}) \\ \hline -2x + (3 - \frac{3}{2}) \end{array} \right| x + \frac{1}{2}$$

Power of remainder is less than the power of dividend and divisor

or $-2x + \frac{3}{2}$. So Remainder = $-2x + \frac{3}{2}$ and quotient = $x + \frac{1}{2}$

Example-5. Divide the polynomial $2x^3 + 4x - 3$ by the polynomial $x - 2$.

Solution: Here, dividend is $2x^3 + 4x - 3$ which we can write as $2x^3 + 0x^2 + 4x - 3$ and divisor is $x - 2$.

Quotient and remainder are also polynomials.

$$\begin{array}{r|l} \text{Now, } (x-2) & \begin{array}{r} 2x^3 + 0x^2 + 4x - 3 \\ 2x^3 - 4x^2 \\ \hline (-) \quad (+) \\ 4x^2 + 4x - 3 \\ 4x^2 - 8x \\ \hline (-) \quad (+) \\ 12x - 3 \\ 12x - 24 \\ \hline (-) \quad (+) \\ 21 \end{array} & 2x^2 + 4x + 12 \end{array}$$

$$\text{Quotient} = 2x^2 + 4x + 12$$

$$\text{Remainder} = 21$$

Example-6. If divisor = $3x+1$, quotient = $2x-1$, remainder is 4 then find the dividend.

Solution: \therefore Dividend = Divisor \times Quotient + Remainder

$$= (3x+1) \times (2x-1) + 4$$

$$= 3x(2x-1) + 1(2x-1) + 4$$

$$= 6x^2 - 3x + 2x - 1 + 4$$

$$\text{Dividend} = 6x^2 - x + 3$$

Example-7. Prove that on dividing $(2x^3 + x^2 - 5x + 2)$ by $(x + 2)$ the remainder is zero.

Solution:

$$\begin{array}{r|l} (x+2) & \begin{array}{r} 2x^3 + x^2 - 5x + 2 \\ 2x^3 + 4x^2 \\ \hline (-) \quad (-) \\ -3x^2 - 5x + 2 \\ -3x^2 - 6x \\ \hline (+) \quad (+) \\ x + 2 \\ x + 2 \\ \hline (-) \quad (-) \\ 0 \end{array} & 2x^2 - 3x + 1 \end{array}$$

Clearly, remainder is zero.



Try These

Write the polynomial $x^2 + 2xy + y^2$ in the form of factors and divide by $x + y$.

Example-8. Divide the polynomial $a^3 - 3a^2b + 3ab^2 - b^3$ by the polynomial $a - b$

Solution : Here, dividend = $a^3 - 3a^2b + 3ab^2 - b^3$ and divisor = $a - b$.

$a - b$	$a^3 - 3a^2b + 3ab^2 - b^3$ $a^3 - a^2b$ (-) (+)	$a^2 - 2ab + b^2$
	$-2a^2b + 3ab^2 - b^3$ $-2a^2b + 2ab^2$ (+) (-)	
	$ab^2 - b^3$ $ab^2 - b^3$ (-) (+)	
	0	

Exercise - 1

1. Find the quotient and remainder on dividing polynomial $x^2 - x + 1$ by $x + 1$.
2. Find the quotient and remainder on dividing $6x^2 - 5x + 1$ by $2x - 1$.
3. Find the quotient and remainder on dividing $2y^3 + 4y^2 + 3y + 1$ by $y + 1$
4. Find the quotient and remainder on dividing $x^5 + 5x + 3x^2 + 5x^3 + 3$ by $4x + x^2 + 2$.
5. Find the quotient and remainder on dividing $x^2 - 2xy + y^2$ by $x - y$.
6. Divide polynomial a by polynomial $a - b$.
7. If divisor = $3x^2 - 2x + 2$, quotient = $x + 1$, remainder = 3 then what is the dividend.
8. If divisor = $4x - 7$, quotient = $x + 1$, remainder = 0 then what is the dividend.
9. Prove that on dividing the polynomial $4x^3 + 3x^2 + 2x - 9$ by $x - 1$ the remainder is zero.
10. Verify whether on dividing polynomial $x^2 - 5x + 3$ by $x - 3$ the remainder is zero or not.
11. If the area of a rectangle is $45x^2 + 30x$ square meter and its breadth is $15x$ meter then what will be the length?
12. A line segment AB whose length is $28x$ unit is to be divided into two equal parts. What will be the length of each part?



Remainder Theorem

Now, we go through various examples of division again. Do you find any important points?

We can say that "If we divide a polynomial $f(x)$ by $(x-a)$ then remainder is $f(a)$." This is remainder theorem. Meaning of $f(a)$ is the value of f when $x = a$.

Proof: \because Dividend = Divisor \times Quotient + Remainder

$$\text{Now, } f(x) = (x-a)q(x) + r$$

Value of $f(x)$ is as follows when $x = a$

$$f(a) = (a-a).q(a) + r$$

$$f(a) = 0.q(a) + r$$

$$f(a) = 0 + r$$

$$\text{Or } f(a) = r$$

Since r is called remainder therefore here remainder = $f(a)$

We divide $f(x)$ by $(x-a)$ and find that remainder is $f(a)$.

Therefore, we can say that if we divide a polynomial $f(x)$ by $(x-a)$ then remainder is $f(a)$.

Try These



If divisor of $f(x)$ is $x+a$ then find remainder.

(i) $f(x) = 2x - a$ (ii) $f(x) = x^2 - a^2$ (iii) $f(x) = x^2 - 2x + 1$

Now, by using remainder theorem we can find remainder without doing division if we know dividend and divisor.

Example-9. Find the remainder when we divide dividend $p(x) = 3x^4 - x^3 + 30x - 1$ by the following:

(a) $x + 1$

(b) $2x - 1$

Solution: (a) Dividend $p(x) = 3x^4 - x^3 + 30x - 1$

and divisor is $g(x) = x + 1$

Then, remainder = ?

We know by the remainder theorem that remainder $r = p(a)$ when division is given by $x - a$.

\therefore Here divisor is $x + 1$ and remainder $r = p(-1)$

On putting $x = -1$ in $p(x)$

Remainder = $p(-1)$

$$= 3(-1)^4 - (-1)^3 + 30(-1) - 1$$

$$= 3 + 1 - 30 - 1$$

Remainder = -27

When divisor is $x - a$ then remainder $r = f(a)$ but when divisor is $x + a$ then remainder is $r = f(-a)$.

Solution: (b) Dividend $p(x) = 3x^4 - x^3 + 30x - 1$

and divisor $g(x) = 2x - 1$

and remainder = $p(a)$

Here, we will write $2\left(x - \frac{1}{2}\right)$ as $2x - 1$. Now $\frac{1}{2}$ is appearing in place of a .

So, remainder = $p\left(\frac{1}{2}\right)$

$$= 3\left(\frac{1}{2}\right)^4 - \left(\frac{1}{2}\right)^3 + 30 \times \frac{1}{2} - 1$$

$$= 3 \times \frac{1}{16} - \frac{1}{8} + 15 - 1$$

$$= \frac{3}{16} - \frac{1}{8} + 14$$

$$= \frac{3-2}{16} + 14$$

$$= \frac{1}{16} + 14$$

$$\text{Remainder} = 14\frac{1}{16}$$



Example-10. Find remainder by using remainder theorem if dividend and divisor are $p(x) = 2x^2 - 3x + 6$, $g(x) = x - 2$ respectively.

Solution: Here, dividend $p(x) = 2x^2 - 3x + 6$

and divisor $g(x) = x - 2$

Then by remainder theorem

$$\begin{aligned} \text{remainder} \quad r &= p(2) \\ &= 2(2)^2 - 3(2) + 6 \\ r &= 8 \end{aligned}$$

Example-11. When a polynomial $f(x)$ is divided by $x^2 - 4$ then we get remainder $5x + 6$. If the same polynomial is divided by $x - 2$ then what will be the remainder?

Solution : Here dividend is $f(x)$ and divisors are $x^2 - 4$ and $x - 2$. When $f(x)$ is divided by $x^2 - 4$ then remainder is $5x + 6$. We can write this in the following way:-

\therefore Dividend = Divisor \times Quotient + Remainder.

$$f(x) = (x^2 - 4) \times q(x) + (5x + 6)$$

Now, we know that once dividend and divisor are known then we can find remainder with the help of remainder theorem.

Since, $x - 2$ is a divisor of $f(x)$.

So, by remainder theorem,

$$\begin{aligned} \text{Remainder} &= f(2) \\ &= (2^2 - 4) \times q(2) + (5 \times 2 + 6) \\ &= (4 - 4) \times q(2) + 10 + 6 \\ &= 0 \times q(2) + 16 \end{aligned}$$

$$\text{Remainder} = 16$$

So, when $f(x)$ is divided by $x - 2$ then remainder will be 16.

Think and Discuss



1. In the above examples can we find the remainder if another divisor $x + 2$ is used in place of second divisor $(x - 2)$? If yes, then find the remainder.
2. Can you see any particular or unique relationship between the divisors in the above examples? Find this particular relationship with the help of your friends. If there is no relationship between the divisors then can we still find the remainder? Try to get the answer by taking a example.

The Factor Theorem

What does it mean when we are dividing a polynomial dividend by another polynomial and remainder comes as zero. Do we find a new relationship between dividend and divisor when remainder becomes zero?

Now we will try to understand the relationship of dividend and divisor by taking an example of algebra where remainder becomes zero, then use this to find relationship in polynomials.

We take 25 as a dividend and 5 as divisor and then see what will be the quotient and remainder.

$$\begin{array}{r}
 \text{Dividend} \\
 \text{Divisor } 5 \left| \begin{array}{r} 25 \\ -25 \\ \hline 0 \end{array} \right. \text{ Quotient} \\
 \text{Remainder}
 \end{array}$$

\therefore Dividend = Quotient \times Divisor + Remainder.

$$25 = 5 \times 5 + 0$$

$$25 = 5 \times 5$$

By this relationship we can say that divisor 5 is a factor of dividend 5.

Try These

Divide 15 by 3 and write it in the above form and check whether there is also some relationship.



Does the same kind of relation appear in the division of polynomials?

Example-12. What will be the quotient and remainder if the polynomial $x^2 - 16$ is divided by polynomial $x - 4$.

Solution :

$$\begin{array}{r}
 \text{Dividend} \\
 \text{Divisor } (x-4) \left| \begin{array}{r} x^2 - 0x - 16 \\ -(x^2 - 4x) \\ \hline 4x - 16 \\ -(4x - 16) \\ \hline 0 \end{array} \right. \text{ Quotient} \\
 \text{Remainder}
 \end{array}$$

Clearly, quotient is $x + 4$ and remainder is 0.

Now, write this in the following form

$$\therefore \text{Dividend} = \text{Divisor} \times \text{Quotient} + \text{Remainder}$$

$$x^2 - 16 = (x - 4)(x + 4) + 0$$

$x^2 - 16 = (x - 4)(x + 4)$. In the above example, we can see that product of $(x - 4)$ and $(x + 4)$ is $x^2 - 16$. This means that the divisor $(x - 4)$ is a factor of $x^2 - 16$. But we can say this only when the remainder is zero.

Find out if $(x + 4)$ is a factor of $x^2 - 16$.

We can say that a divisor is a factor of dividend if remainder is zero on dividing dividend by the divisor. This statement is said to be the simplest form of the remainder theorem. In a way, factor theorem is expanded form of remainder theorem.

Proof of factor theorem

This statement can be written in the following manner in the form of a theorem. To write this in the form of a theorem, we need to prove it first.

Theorem : If $x = a$, such that a is zero of polynomial $f(x)$ where remainder $f(a) = 0$ then $(x - a)$, is a factor of $f(x)$

If on dividing $f(x)$ by $(x - a)$, the remainder $f(a) = 0$, then $(x - a)$ is a factor of $f(x)$.

Proof : We can write the relationship between dividend, divisor, quotient and remainder in the following way .

$$\text{i.e. } f(x) = g(x) \cdot q(x) + r(x)$$

By the remainder theorem we know that if $f(x)$ is divided by $(x - a)$ then remainder is $f(a)$.

$$\therefore \text{Dividend} = \text{Divisor} \times \text{Quotient} + \text{Remainder}$$

$$\text{i.e. } f(x) = (x - a) \cdot q(x) + f(a)$$

Now, if remainder $f(a) = 0$

$$\text{Then, } f(x) = (x - a) \cdot q(x)$$

Clearly, $(x - a)$ is a factor of $f(x)$.

The values of x for which the value of polynomial $f(x)$ is zero are called zeroes of the polynomial.

The converse of this theorem is also true therefore, if divisor is a factor of a dividend, then remainder is zero.

Converse : Remainder is zero if $(x-a)$ is a factor of $f(x)$.

Proof : Since $(x-a)$ is a factor of $f(x)$.

i.e. $x = a$ is a zero of $f(x)$

$$f(x) = (x-a).q(x)$$

On putting $x = a$ in

$$f(a) = (a-a).q(a)$$

$$f(a) = 0$$

Clearly if $(x-a)$ is a factor of $f(x)$ then remainder $f(a)$ is zero.



1. If there are two factors $(x-a)$, $(x-b)$ of a polynomial, then

$$f(x) = (x-a)(x-b).q(x)$$
2. If there are three factors $(x-a)$, $(x-b)$, $(x-c)$ of a polynomial then

$$f(x) = (x-a)(x-b)(x-c).q(x)$$

We can tell whether a divisor is a factor of dividend polynomial or not without doing division with the help of factor theorem. You will understand the importance of factor theorem more by the following example:-

Example-13. Is $(x-2)$, a factor of polynomial $p(x) = x^3 - 3x^2 + 4x - 4$?

Solution : If $(x-2)$, is a factor of polynomial $p(x) = x^3 - 3x^2 + 4x - 4$, then on putting

$x = 2$ remainder should be zero.

Putting $p(x)$ in $x = 2$

$$p(2) = (2)^3 - 3(2)^2 + 4(2) - 4$$

$$= 8 - 3 \times 4 + 8 - 4$$

$$= 8 - 12 + 4$$

$$= 12 - 12$$

$$p(2) = 0$$

Clearly, $p(2) = 0$ so $(x-2)$ is a factor of $p(x)$

Example-14. Is $(x-a)$ a factor of the polynomial $p(x) = x^3 - ax^2 + 5x - 5a$?

Solution : If on putting $x = a$ in polynomial $p(x) = x^3 - ax^2 + 5x - 5a$, $p(a) = 0$

then we can say that $(x-a)$ is a factor $p(x)$.

On putting $x = a$

$$p(a) = a^3 - a.a^2 + 5a - 5a$$

$$= a^3 - a^3 + 0$$

$$p(a) = 0$$

Clearly, $p(a) = 0$ so $(x-a)$ is a factor of $p(x)$

Example-15. Find the value of k if $(x-1)$ is a factor of $p(x) = x^2 + x + k$

Solution : Since $(x-1)$ is a factor of $x^2 + x + k$. Then we can say by the converse of

factor theorem that on putting $x = 1$, the remainder $p(1)$ will be zero

$$\text{So, } p(1) = 0$$

$$1^2 + 1 + k = 0$$

$$1 + 1 + k = 0$$

$$2 + k = 0$$

$$k = -2$$

Exercise - 2



1. If $p(x) = x^3 + 3x^2 - 5x + 8$ is divided by the following, then find the remainder with the help of remainder theorem.

(i) $x+1$ (ii) $2x-1$ (iii) $x+2$ (iv) $x-4$ (v) $x + \frac{1}{3}$

2. Verify in the following whether $g(x)$ is a factor of $p(x)$.

(i) $g(x) = x-3$; $p(x) = x^3 - 4x^2 + x + 6$

(ii) $g(x) = x+1$; $p(x) = 2x^3 + x^2 - 2x + 1$

(iii) $g(x) = x-2$; $p(x) = x^4 - x^3 - x^2 - x - 2$

(iv) $g(x) = x-1$; $p(x) = x^3 + 5x^2 - 5x + 1$

(v) $g(y) = y+4$; $p(y) = y^2 + 2y - 1$

3. Find the value of a when $g(x)$ is a factor of $p(x)$.
- (i) $g(x) = x + 1$; $p(x) = x^2 + ax + 2$
- (ii) $g(x) = x - 1$; $p(x) = ax^2 - 5x + 3$
- (iii) $g(x) = x + 2$; $p(x) = 2x^2 + 6x + a$
- (iv) $g(t) = t - 3$; $p(t) = t^2 + 2at - 2a + 3$
- (v) $g(y) = y + 5$; $p(y) = y^2 - 2y + a$
4. If a polynomial $f(x)$ is divided by $x^2 - 9$ then remainder is $3x + 2$, what will be the remainder when the same polynomial is divided by $(x - 3)$?
5. If a polynomial $f(x)$ is divided by $x^2 - 16$ then remainder is $5x + 3$, what will be the remainder when the same polynomial is divided by $(x + 4)$?

Factoring Polynomials

You have already seen that if a polynomial is divided by any other polynomial and the remainder is zero then we can say that the divisor polynomial is a factor of the dividend polynomial. If we can't find the factors of a polynomial using the factor theorem then how can we find the factors of a polynomial? On the basis of the type of the polynomial, we can get its factors. We will discuss here factors of linear polynomials and quadratic polynomials.

Factoring of a number means splitting it into its prime factors such that we can get the same number on multiplying those factors.

Let us think about the factors of 6

$$6 = 2 \times 3$$

Here 6 is written in the form of its prime factors 2 and 3 whose product is 6.

Similarly, 12 can be written as

$$12 = 2 \times 2 \times 3$$

Similarly, when we talk about factoring polynomials it means splitting a polynomial into simple polynomials in such a way that we get the same polynomial by multiplying the factors.

There are some methods of factoring polynomials, for example, sometimes we identify common factors for factorising it and sometimes by using the following identities.

$$(a + b)^2 = a^2 + 2ab + b^2$$

$$(a - b)^2 = a^2 - 2ab + b^2$$

$$a^2 - b^2 = (a + b)(a - b)$$

To get factors by taking common factors

It is possible to find factors by common factors method only if in each term of the polynomial that factor is present. We can understand this by some examples which are given below:

Example-16. Find the factors of $12x + 4x^2$.

Solution : $12x + 4x^2 = 4 \times 3 \times x + 4 \times x \times x$ (Polynomial $4x$ is present in both terms)
 $= 4x(3 + x)$

Example-17. Find the factors of $ab + ac + a^2$.

Solution : $ab + ac + a^2 = a(b + c + a)$ (a is in all three terms)
 $= a(a + b + c)$

Example-18. Find the factors of $2x^3 + 4x$.

Solution : $2x^3 + 4x = 2 \times x \times x^2 + 2 \times 2 \times x$
 $= 2x(x^2 + 2)$

Factorisation by using identities

Were you able to find the factors of $x^2 - 4$, $x^2 + 6x + 9$, $x^2 + 5x + 6$ by taking common factors.

Let us consider the following examples $x^2 - 4$, $x^2 + 6x + 9$ and $x^2 + 5x + 6$. There are no common terms in each of these polynomials. We cannot find factors of these polynomials by taking a common polynomial. Then what should we do?

$x^2 - 4$ can be factorized as shown below:

$$x^2 - 4 = x^2 - 2^2 \qquad \because \text{Identity } a^2 - b^2 = (a + b)(a - b)$$

$$= (x + 2)(x - 2)$$

Can we write $x^2 + 6x + 9$ in the form of an identity?

Yes, we can write $x^2 + 6x + 9$ in the form of $(a + b)^2 = a^2 + 2ab + b^2$

$$\begin{aligned}x^2 + 6x + 9 &= x^2 + 2 \times 3x + 3^2 \\ &= (x + 3)^2 \\ &= (x + 3)(x + 3)\end{aligned}$$

Try These

1. Factorise $x^2 - 16$

2. Factorise $4x^2 - 20x + 25$



Find factors by splitting the middle term of a polynomial which is in the form $ax^2 + bx + c$

We again consider the factorisation of $x^2 + 5x + 6$. Can we find factors of this by writing this in the form of an identity?

You will find that you are not able to write this polynomial in the form of an identity.

We need to split the middle term into two parts for this type of polynomial. The two parts should be such that their sum is equal to middle term and their product is equal to product of first and last term of the polynomial.

Now, we factorise $x^2 + 5x + 6$

$$\begin{aligned}x^2 + 5x + 6 &= x^2 + (2 + 3)x + 2 \times 3 \\ &= x^2 + 2x + 3x + 2 \times 3 \\ &= (x^2 + 2x) + (3x + 2 \times 3) \\ &= x(x + 2) + 3(x + 2) \\ &= (x + 2)(x + 3)\end{aligned}$$



To understand this method we use the following expression:

$$\begin{aligned}(x + a)(x + b) &= x^2 + (a + b)x + ab \\ &= 1 \cdot x^2 + (a + b)x + ab\end{aligned}$$

The expression which is product of $(x + a)$ and $(x + b)$ can be written in the form of $Ax^2 + Bx + C$. Then we will see that here, $A = 1$, $B = a + b$ and $C = ab$.

To find the factors of any polynomial in the form $Ax^2 + Bx + C$ coefficient A of first term x^2 is multiplied with the last term C . Then we try to find two factors of the product obtained whose sum is equal to the coefficient B of the middle term x .

Let us understand this by looking at the following example:-

Example-19. Factorise the polynomial $x^2 + 3x + 2$.

Solution : On comparing polynomial $x^2 + 3x + 2$ with $Ax^2 + Bx + C$

$$A = 1, B = 3, C = 2$$

$$\text{Since, } A \times C = 1 \times 2 = 2,$$

Following are the possible factors of 2

$$1 \times 2 \quad | \quad (-1) \times (-2)$$

Factors $1 + 2 = 3$ but $(-1) + (-2) = -3$ which means that 1×2 is the only correct factorization of 2 where sum is 3 (which is equal to B).

$$\begin{aligned} \text{So, } x^2 + 3x + 2 &= x^2 + (1+2)x + 1 \times 2 \\ &= x^2 + 1.x + 2.x + 1 \times 2 \\ &= (x^2 + 1.x) + (2.x + 1 \times 2) \\ &= x(x+1) + 2(x+1) \\ &= (x+1)(x+2) \text{ are the required factors.} \end{aligned}$$

Example-20. Factorise the polynomial $6x^2 - 5x - 6$.

Solution : On comparing polynomial $6x^2 - 5x - 6$ with $Ax^2 + Bx + C$

$$A = 6, B = -5, C = -6$$

$$\text{Since, } A \times C = 6 \times (-6) = -36$$

Possible factors of -36 are:-

-1×36	$1 \times (-36)$
-2×18	$2 \times (-18)$
-3×12	$3 \times (-12)$
-4×9	$4 \times (-9)$
-6×6	$6 \times (-6)$

Clearly in the above example, 4 and -9 are the factors of $AC = -36$, as sum of 4 and -9 is -5 which is equal to the middle term B .

$$\begin{aligned} \text{So, } 6x^2 - 5x - 6 &= 6x^2 + (4 - 9)x - 6 \\ &= 6x^2 + 4x - 9x - 6 \\ &= (6x^2 + 4x) - 1(9x + 6) \\ &= 2x(3x + 2) - 3(3x + 2) \\ &= (3x + 2)(2x - 3) \text{ are the required factors.} \end{aligned}$$

Example-21. Factorise the polynomial $14x^2 + 19x - 3$.

Solution : On comparing polynomial $14x^2 + 19x - 3$ with $Ax^2 + Bx + C$

$$A = 14, \quad B = 19, \quad C = -3$$

$$\text{Since, } A \times C = 14 \times (-3) = -42$$

Following are the possible factor of -42 .

-1×42	$1 \times (-42)$
-2×21	$2 \times (-21)$
-3×14	$3 \times (-14)$
-6×7	$6 \times (-7)$



Clearly, in the above, -2 and 21 are the factors of $A \times C = -42$ as sum of -2 and 21 is $-2 + 21 = 19$ which is equal to the middle term B .

$$\begin{aligned} \text{So, } 14x^2 + 19x - 3 &= 14x^2 + (-2 + 21)x - 3 \\ &= 14x^2 - 2x + 21x - 3 \\ &= (14x^2 - 2x) + (21x - 3) \\ &= 2x(7x - 1) + 3(7x - 1) \\ &= (7x - 1)(2x + 3) \text{ are the required factors.} \end{aligned}$$

Example-22. Factorise the polynomial $4\sqrt{3}x^2 + 5x - 2\sqrt{3}$.

Solution : On comparing the polynomial $4\sqrt{3}x^2 + 5x - 2\sqrt{3}$ with $Ax^2 + Bx + C$

$$A = 4\sqrt{3}, \quad B = 5, \quad C = -2\sqrt{3}$$

$$\text{So, } A \times C = 4\sqrt{3} \times (-2\sqrt{3}) = -8 \times 3 = -24$$

Following are the possible factors of -24 .

-1×24	$1 \times (-24)$
-2×12	$2 \times (-12)$
-3×8	$3 \times (-8)$
-6×4	$6 \times (-4)$

Clearly, -3 and 8 are the factors of $A \times C = -24$, since sum of -3 and 8 is $-3 + 8 = 5$, which is equal to middle term B .

$$\begin{aligned} \text{So, } 4\sqrt{3}x^2 + 5x - 2\sqrt{3} &= 4\sqrt{3}x^2 + (-3 + 8)x - 2\sqrt{3} \\ &= 4\sqrt{3}x^2 - 3x + 8x - 2\sqrt{3} \\ &= (4\sqrt{3}x^2 - 3x) + (8x - 2\sqrt{3}) \\ &= (4\sqrt{3}x^2 - \sqrt{3}\sqrt{3}x) + 2(4x - \sqrt{3}) \\ &= \sqrt{3}x(4x - \sqrt{3}) + 2(4x - \sqrt{3}) \\ &= (4x - \sqrt{3})(\sqrt{3}x + 2) \end{aligned}$$

Think and Discuss



Is it possible for a quadratic polynomial to have more than two factors? Go through the examples of this chapter. Work with your friends to form quadratic polynomials and verify if it is possible to get more than two factors for any of them.

Exercise-3

Factorize the following polynomials by splitting the middle term:-

(1) $x^2 - 3x - 4$

(2) $x^2 + 2x + 1$

(3) $x^2 + x - 12$

(4) $x^2 - 8x + 15$

(5) $t^2 - 4t - 21$

(6) $-y^2 + 35y + 156$

(7) $7x^2 - 2x - 5$

(8) $12x^2 - 24x + 12$

(9) $6x^2 - 7x - 3$

(10) $14y^2 + 19y - 3$

(11) $\sqrt{3}y^2 + 9y + 6\sqrt{3}$

(12) $144x^2 + 24x + 1$



Value and Zeroes of a Quadratic Polynomial

Consider the polynomial $p(x) = x^2 - 6x + 9$. If we put $x = 1$ in the polynomial

$$\begin{aligned} \text{Then, } p(1) &= (1)^2 - 6(1) + 9 \\ &= 1 - 6 + 9 \\ &= 4 \end{aligned}$$

On putting $x = 1$ we get 4 as the value of $p(1)$. This is the value of the polynomial for $x = 1$. We can also say that the value of $p(x)$ at $x = 1$ is 4. Similarly, we can get the values of $p(-1)$, $p(2)$ etc.

We see that when $x = 3$

$$\begin{aligned} \text{then } p(3) &= 3^2 - 6(3) + 9 \\ &= 9 - 18 + 9 \\ &= 0 \end{aligned}$$

The value of the polynomial is 0 for $x = 3$. So, we can say that 3 is a zero of the polynomial.

Now, we will find the zeroes of the polynomial in the following examples.

Example-23. Find the zeroes of the polynomial $x^2 - 3x - 4$.

Solution : Let $p(x) = x^2 - 3x - 4$

Here, we need to find a value of x for which the value of polynomial is zero.

If $x = 1$

$$\begin{aligned} \text{then } p(1) &= (1)^2 - 3(1) - 4 \\ &= 1 - 3 - 4 \\ &= -6 \end{aligned}$$

If $x = -1$

$$\begin{aligned} \text{then } p(-1) &= (-1)^2 - 3(-1) - 4 \\ &= 1 + 3 - 4 \\ &= 0 \end{aligned}$$

On putting $x = -1$ the value of the polynomial is zero so -1 is a zero of the polynomial. Are there any more zeroes for this polynomial? To know this we can try to put more values of x . But we can use the factors of a polynomial to more easily find all its zeroes.

Find the factors of the polynomial $x^2 - 3x - 4$

$$\begin{aligned}x^2 - 3x - 4 &= x^2 - 4x + x - 4 \\ &= (x^2 - 4x) + 1(x - 4) \\ &= x(x - 4) + 1(x - 4) \\ &= (x - 4)(x + 1)\end{aligned}$$

The zero of this polynomial is that value of x for which the value of polynomial is zero.

$$\begin{aligned}\text{So, } x^2 - 3x - 4 &= 0 \\ \Rightarrow (x - 4)(x + 1) &= 0 \\ \Rightarrow (x - 4) = 0 \quad \text{and} \quad (x + 1) &= 0 \\ \Rightarrow x - 4 = 0 \quad \text{and} \quad x + 1 = 0 \\ \Rightarrow x = 4 \quad \text{and} \quad x = -1\end{aligned}$$

Here we see that for both $x = -1$ and $y = 4$ the value of the polynomial is zero.

So -1 and 4 are zeroes of the polynomial.

In the above example -1 and 4 are zeroes of the polynomial while $(x - 4)$ and $(x + 1)$ are factors of the polynomial. We see that on making the factors of the polynomial zero we get zeroes of the polynomial. So if we know the factors of a polynomial then we can get zeroes of the polynomial. Can we find the factors if zeroes of the polynomial are given?

Try These



1. Find factors and zeroes of the polynomial $x^2 - 9$.
2. What will be the factors of a polynomial if its zeroes are 4 and -1 .

Relationship between Zeroes and Coefficients of a Polynomial

Zeroes of a polynomial $x^2 - 5x + 6$ are 3 and 2 , then its the factors are $(x - 3)$ and $(x - 2)$.

$$\text{i.e. } x^2 - 5x + 6 = 1.(x - 3)(x - 2)$$

Now, think about the factors and zeroes of the polynomial $4x^2 - 4x + 1$

$$\begin{aligned}
 4x^2 - 4x + 1 &= 4x^2 - 2x - 2x + 1 \\
 &= (4x^2 - 2x) - 1(2x - 1) \\
 &= 2x(2x - 1) - 1(2x - 1) \\
 &= (2x - 1)(2x - 1) \\
 &= 2\left(x - \frac{1}{2}\right) \times 2\left(x - \frac{1}{2}\right) \\
 &= 4\left(x - \frac{1}{2}\right)\left(x - \frac{1}{2}\right)
 \end{aligned}$$



So, the factors of $4x^2 - 4x + 1$ are $4\left(x - \frac{1}{2}\right)\left(x - \frac{1}{2}\right)$ and clearly the zeroes of the polynomial are $\frac{1}{2}, \frac{1}{2}$.

Do you see any important point (pattern) in the factors of $x^2 - 5x + 6$ and $4x^2 - 4x + 1$. The coefficient of x^2 in $x^2 - 5x + 6$ is seen as one of its factors. Similarly, 4 which is the coefficient of x^2 in polynomial $4x^2 - 4x + 1$ is a factor of this polynomial. This means that the polynomial $ax^2 + bx + c$ whose zeroes are α and β and where a, b, c are real numbers where $a \neq 0$ can be written in the following way:-

$$ax^2 + bx + c = k(x - \alpha)(x - \beta) \quad ; \quad k = a$$

Where k is a real number and $k \neq 0$

$$\text{Again } ax^2 + bx + c = kx^2 - k(\alpha + \beta)x + k\alpha\beta \quad (\text{on multiplication})$$

On comparing the coefficients of x^2 , x and the constant terms on both sides of this equation

$$a = k; \quad b = -k(\alpha + \beta); \quad c = k\alpha\beta$$

$$\frac{b}{-k} = \alpha + \beta \quad ; \quad \frac{c}{k} = \alpha\beta$$

$$\frac{b}{-a} = \alpha + \beta$$

So $\alpha + \beta = \frac{-b}{a}$ and $\alpha\beta = \frac{c}{a}$ (On multiplying the numerator and denominator by -1)

We can say that in a quadratic polynomial $ax^2 + bx + c$

$$\text{Sum of zeroes, } \alpha + \beta = \frac{\text{Coefficient of } -x}{\text{Coefficient of } x^2}$$

$$\text{and product of zeroes } \alpha\beta = \frac{\text{Constant term}}{\text{Coefficient of } x^2}$$

Let us understand the relationship between zeroes and coefficient of polynomials through some examples.

Example-24. Find the sum and product of the zeroes of the polynomial $6x^2 + 13x + 7$.

Solution : On comparing the polynomial $6x^2 + 13x + 7$ with $ax^2 + bx + c$

$$a = 6, \quad b = 13, \quad c = 7$$

$$\therefore \text{Sum of zeroes} = \frac{-b}{a}$$

$$\therefore \text{Sum of zeroes} = \frac{-13}{6}$$

$$\therefore \text{Product of zeroes} = \frac{c}{a}$$

$$\therefore \text{Product of zeroes} = \frac{7}{6}$$

Example-25. Find the sum and product of the zeroes of the polynomial $4x^2 + 4\sqrt{3}x + 3$ in the form $ax^2 + bx + c$.

Solution : On comparing the polynomial $4x^2 + 4\sqrt{3}x + 3$ with $ax^2 + bx + c$

$$\therefore \text{Sum of zeroes} = \frac{-b}{a}$$

$$\begin{aligned} \therefore \text{Sum of zeroes} &= \frac{-(4\sqrt{3})}{4} \\ &= -\sqrt{3} \end{aligned}$$

$$\therefore \text{Product of zeroes} = \frac{c}{a}$$

$$\therefore \text{Product of zeroes} = \frac{3}{4}$$



Think and Discuss

Can we find the polynomial if its zeroes are given? Form a polynomial using any two zeroes.



Exercise - 4

1. Zeroes of some polynomials of the form $ax^2 + bx + c$ are given below :

Find the factors of the polynomials.

(i) $(3, 4)$ (ii) $(-2, -3)$ (iii) $\left(\frac{1}{2}, \frac{-1}{2}\right)$

(iv) $(15, 17)$ (v) $(-18, 12)$

2. Find the sum and product of zeroes of the following polynomials.

(i) $x^2 + 10x + 24$

(iv) $-5x^2 + 3x + 4$

(ii) $2x^2 - 7x - 9$

(v) $x^2 + x - 12$

(iii) $x^2 + 11x + 30$



What We Have Learnt

- The process of division in polynomials is slightly different from division in arithmetic. Here, we have to be careful about the exponents of the variables.
- For division of polynomials we have to write the dividend and divisor in descending order of their exponents.
- Long division method is also used to divide polynomials.
- In long division method, we keep repeating the process of division till we get zero as the remainder.
- In division of polynomials, the quotient and remainder are also polynomials.
- If a polynomial $f(x)$ is divided by $(x - a)$ then remainder is $f(a)$. This is called the remainder theorem.
- $(x - a)$ is a factor of polynomial $f(x)$, if $f(a) = 0$. Also, if $(x - a)$ is a factor of $f(x)$, then $f(a) = 0$.
- Quadratic polynomials have two zeroes.

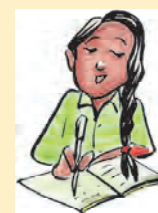

ANSWER KEY

Exercise - 1

1. Quotient = $x-2$, Remainder = 3
2. Quotient = $3x-1$, Remainder = 0
3. Quotient = $2y^2 + 2y + 1$, Remainder = 0
4. Quotient = $x^3 - 4x^2 + 19x - 65$, Remainder = $227x + 133$
5. Quotient = $x - y$, Remainder = 0
6. Quotient = 1, Remainder = b
7. $3x^3 + x^2 + 5$
8. $4x^2 - 3x - 7$
10. Remainder is not zero
11. $(3x + 2)$ meter
12. $14x$ meter

Exercise - 2

1. (i) 15 (ii) $\frac{51}{8}$ (iii) 22 (iv) 100 (v) $\frac{269}{27}$
2. (i) $(x-3)$ is a factor of given polynomial.
 (ii) $(x+1)$ is not a factor of given polynomial.
 (iii) $(x-2)$ is a factor of given polynomial.
 (iv) $(x-1)$ is not a factor of given polynomial.
 (v) $(y+4)$ is not a factor of given polynomial.
3. (i) $a = 3$ (ii) $a = 2$ (iii) $a = 4$ (iv) $a = -3$ (v) $a = -35$
4. Remainder = 11
5. Remainder = -17

Exercise - 3

1. $(x-4)(x+1)$
2. $(x+1)(x+1)$
3. $(x+4)(x-3)$
4. $(x-5)(x-3)$
5. $(t-7)(t+3)$
6. $-(y-39)(y+4)$
7. $(7x+5)(x-1)$
8. $12(x-1)(x-1)$
9. $(2x-3)(3x+1)$
10. $(2y+3)(7y-1)$
11. $(y+2\sqrt{3})(\sqrt{3}y+3)$
12. $(12x+1)^2$

Exercise - 4

1. (i) $(x-3)(x-4)$ (ii) $(x+2)(x+3)$ (iii) $\left(x-\frac{1}{2}\right)\left(x+\frac{1}{2}\right)$
 (iv) $(x-15)(x-17)$ (v) $(x+18)(x-12)$
2. (i) -10, 24 (ii) $\frac{7}{2}, -\frac{9}{2}$ (iii) -11, 30
 (iv) $\frac{3}{5}, -\frac{4}{5}$ (v) -1, -12



LINEAR EQUATIONS IN TWO VARIABLES

Reema asked Salma:- If one-fourth portion of a pole is painted blue, one third red and the remaining 10 meters are painted black, what is the height of the pole?

Salma said:- We learnt about linear equations in one variable in a previous class. We know that in such situations we make linear equations in one variable and solve them to find the values of the variables (unknowns).

Reema:- Good! So, how will we determine the length of the pole?

Salma:- If we assume that the total length of the pole is x meters, then

$$\text{length of the blue part} = \frac{x}{4} \text{ meter}$$

$$\text{length of the red part} = \frac{x}{3} \text{ meter}$$

$$\text{length of the black part} = 10 \text{ meter.}$$

Therefore, total length of the pole = length of the blue part + length of the red part + length of the black part

$$x = \frac{x}{4} + \frac{x}{3} + 10$$

$$x = \frac{3x + 4x + 120}{12}$$

$$12x = 7x + 120$$

$$12x - 7x = 120$$

$$5x = 120$$

$$x = \frac{120}{5}$$

$$x = 24 \text{ meters}$$

So, total length of the pole is 24 meters.

Can you tell what will be the length of the blue and red parts of the pole?

Salma and Reema discussed many other problems with each-other and tried to solve them.

Example-1. Salma said to Reema:- My number is two more than your number and the sum of our numbers is 14. Can you find our numbers?

Solution: Reema;- Let us assume that my number = x

Then, your number will be $x + 2$

\therefore The sum of the two numbers is 14

$$\therefore x + x + 2 = 14$$

$$\Rightarrow 2x + 2 = 14$$

$$\Rightarrow 2x = 14 - 2$$

$$\Rightarrow 2x = 12$$

$$\Rightarrow x = \frac{12}{2}$$

$$\Rightarrow x = 6$$

This means that my number is 6 and your number is 8.

Example-2. What is the value of each of the internal angles of the triangle given below?

Solution: \therefore The sum of internal angles of a triangle is 180°

$$\therefore \angle A + \angle B + \angle C = 180^\circ$$

$$x^\circ + (x + 40)^\circ + (x + 20)^\circ = 180^\circ$$

$$\Rightarrow 3x^\circ + 60^\circ = 180^\circ$$

$$\Rightarrow 3x^\circ = 180^\circ - 60^\circ$$

$$\Rightarrow 3x^\circ = 120^\circ$$

$$\Rightarrow x^\circ = \frac{120^\circ}{3}$$

$$\Rightarrow x^\circ = 40^\circ$$

\therefore the value of the internal angles of the given triangles are as follows:

$$\angle A = x^\circ = 40^\circ,$$

$$\angle B = x^\circ + 20^\circ = 40^\circ + 20^\circ = 60^\circ$$

$$\angle C = x^\circ + 40^\circ = 40^\circ + 40^\circ = 80^\circ$$

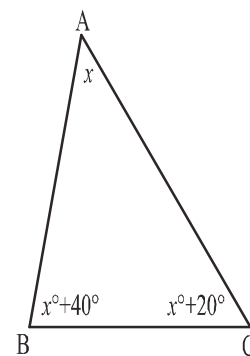

1. A bag contains 50 paisa coins. Find the number of coins in the bag if the total money in the bag is Rs. 50.
2. If one of the internal angles of a right angle triangle is 60° then find the value of the other angles.
3. If father's age is twice the age of his son, then what are their current ages.



Forming equations

Salma and Reema also discussed some other types of questions.

I have Rs. 1 and 50 paisa coins in my bag. If there are 100 coins in all, then find the number of 50 paisa coins and the number of Rs. 1 coins?

Here, we have two different types of coins and their numbers are different. We don't know the number of any of the coins therefore both have to be shown by unknowns. So, we will say that the number of 50 paisa coins is x and the number of Rs. 1 coins is y . We know that the total number of coins in the bag is 100 which means that

$$x + y = 100$$

But we still can't say how many Rs. 1 and 50 paisa coins are there.

Let us see some more examples where we are able to form equations but are not able to find their solutions.

Example-3. There are some deer and some cranes in the forest. The total number of legs is 180. How many deer and how many cranes are there?

Solution: Let the number of deer = x
 Let the number of cranes = y
 Since, one deer has 4 legs
 Therefore, the number of legs of deer = $4x$
 Since, one crane bird has 2 legs
 Therefore, the number of legs of cranes = $2y$

According to the statement,

$$\text{Legs of deer} + \text{Legs of cranes} = 180$$

That is, $4x + 2y = 180$

Example-4. The cost of one copy and two pencils is Rs. 45.

Solution: Let the cost of one copy = Rs. x
 Let the cost of one pencil = Rs. y

Then, the cost of one copy + the cost of two pencils = Rs. 45
 $x + 2y = 45$

Try this



Try to form equations for the following statements

1. The sum of any two numbers is 8.
2. The difference in ages of Shashank and his father is 30 years.
3. A bag has of Rs. 1 and Rs. 5 coins. The total number of coins is 100.
4. The cost of three pens and four copies is Rs. 105.
5. A farm has some hens and some cows and the number of legs is 60.

Simultaneous equations

In the above examples, we were able to form equations but not able to find their solutions.

Let us now discuss the following situations.

A father distributed Rs. 8 among his son, Saurabh and daughter, Santosh. Can we find out how much Saurabh got and how much Santosh got?

If Saurabh got Rs. x and Santosh got Rs. y then the equation will be as follows:

$$x + y = 8 \dots\dots\dots(1)$$

On the basis of this equation, we can say that if Saurabh got Rs. 1 then Santosh got Rs. 7, if Saurabh got Rs. 2 then Santosh got Rs. 6 and so on. We see that if Saurabh got Rs. 7 then Santosh gets Rs. 1. We can summarize the ways of distributing Rs. 8 between Saurabh and Santosh as shown in the table below:

Rupees							
Saurabh	1	2	3	4	5	6	7
Santosh	7	6	5	4	3	2	1

We see that we can't tell how much money Saurabh and Santosh actually got. But suppose we find out that father gave Saurabh three times more money than Santosh then we can write

$$x = 3y \dots\dots\dots(2)$$

In equation (1), if we put $x = 3y$ then we get the following equation in one variable

$$3y + y = 8$$

$$4y = 8$$

$$y = \frac{8}{4}$$

$$y = 2$$

Putting the value of y in equation (2)

$$x = 3y$$

Then $x = 3 \times 2$

$$x = 6$$

This means that Santosh got Rs. 2 and Saurabh got Rs. 6 which is three times Santosh's money.

Similarly, in example-3, when the total number of legs of cranes and deer was 180 then, our equation was $4x + 2y = 180 \dots\dots\dots(1)$

Suppose we know that the sum of eyes of deer and eyes of cranes is 120

That is: $2x + 2y = 120 \dots\dots\dots(2)$ (each deer has 2 eyes and each crane has 2 eyes)

From equation (2)

$$2y = 120 - 2x$$

Putting this in equation (1)

$$\Rightarrow 4x + 120 - 2x = 180$$

$$\Rightarrow 2x = 60$$

$$\Rightarrow x = \frac{60}{2}$$

$$\Rightarrow x = 30$$

x , i.e. the number of deer is 30. Putting this value of x in equation (1)

$$\Rightarrow 4(30) + 2y = 180$$

$$\begin{aligned} \Rightarrow 120 + 2y &= 180 \\ \Rightarrow 2y &= 180 - 120 \\ \Rightarrow 2y &= 60 \\ \Rightarrow y &= \frac{60}{2} \\ \Rightarrow y &= 30 \end{aligned}$$

y , i.e. the number of crane birds is also 30.

In the above examples we saw that in situations where we had two variables but only one equation, we could only estimate the answers. Once we got the second condition and were able to form the second equation, we were able to arrive at the exact answer.

Think and discuss



Can we find the answers to the problems given below? If not, then why?

1. You are given a parallelogram where in the pair of adjacent angles the value of one angle is $\frac{4}{5}$ times that of the other. Find the angles.
2. Some cuckoos and sparrows are sitting on a tree. If the sum of their legs is 36, find the number of cuckoos and the number of sparrows.
3. A fruit-basket contains apples and mangoes. The number of fruits is 39. Another fruit-basket has some mangoes and oranges then find the number of mangoes in the second basket.

Solutions of equations

How can we find the solutions to equations describing different conditions? We need to solve the equations and there are many methods to do so. Let us learn about some of them.

Graphical method

In coordinate geometry or as part of drawing graphs, you have learnt how to depict graphs of equations in two variables. We can draw graphs of equations describing many different conditions and learn about their solutions.

Let us draw the graphs for the equation showing the relation between the legs of cranes and deer and for the equation showing the relation between their eyes. We will see if we can get the solution of the equations from the graph.

For the equation $4x + 2y = 180$ showing the relation between their legs, we will make a table.

$$2y = 180 - 4x$$

$$y = \frac{180 - 4x}{2}$$

$$y = 90 - 2x \quad \dots\dots\dots(3)$$

Let us find the corresponding values of y by putting x = 10, 20, 30...etc. in equation (3).

Table-1				
x	10	20	30	40
y	70	50	30	10

Similarly, for the equation 2x + 2y for eyes

$$2y = 120 - 2x$$

$$y = \frac{120 - 2x}{2}$$

$$y = 60 - x \quad \dots\dots\dots(4)$$

The values of y obtained by putting x = 10,20, 30.... in equation (4) are given in table-2.

Table-2				
x	10	20	30	40
y	50	40	30	20

Now, let us draw a graph using the values given in table-1 and table-2.

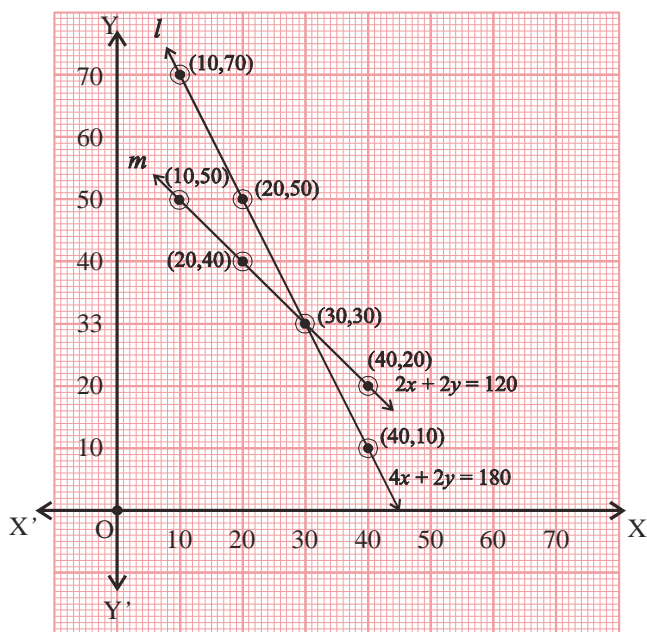

Graph-1

We find that the lines in the graph intersect at the point (30, 30). These are the values for the number of deer and number of cranes, as we had previously calculated.

Try this



Draw graphs for the equations $x + y = 8$ and $x = 3y$ and find the solutions.

The questions given below have also been solved using the same method.

Example:-5. 10 students of class X took part in a quiz. The number of girls taking part in the quiz was four more than the boys. Find the number of girls and the number of boys who took part in the quiz.

Solution: Suppose that the number of boys taking part in the quiz was x and the number of girls was y . Then,

Total number of students = number of boys + number of girls

$$10 = x + y$$

$$\text{Or } x + y = 10 \quad \dots\dots\dots(1)$$

Since the number of girls was four more than the boys, we also get the following equation

$$y = x + 4 \quad \dots\dots\dots(2)$$

Now, to draw the graphs for equations (1) and (2), we will make a table of corresponding values of x and y and use these to draw the graph.

By putting $x = 1, 2, 3, \dots$ in equation (1) we will get the corresponding values of y and these are shown in table-1.

Table - 1

(For $x + y = 10$)

x	1	2	3	4	5	6
y	9	8	7	6	5	4

Similarly, by putting $x = 1, 2, 3, \dots$ in equation (2) we will get the corresponding values of y and these are shown in table-2.

Table - 2

(For $y = x + 4$)

x	1	2	3	4	5	6
y	5	6	7	8	9	10

If we depict the values from table -1 and 2 on graph paper then we get two straight lines l and m . From the graph we can see that these two lines l and m cut or intersect each other at point $(3, 7)$. This point is situated on the straight lines for the two equations.

On this point $x = 3$ and $y = 7$ and the values satisfy both the equations. Hence, this is the solution to our problem.

Thus, the number of boys is 3 and the number of girls is 7.

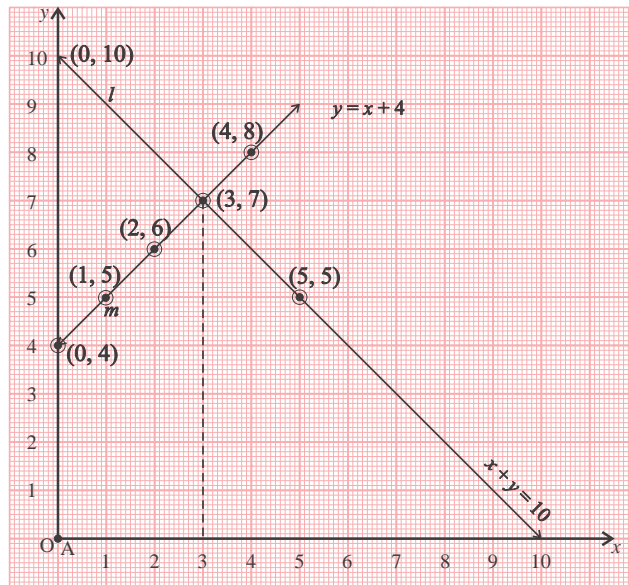

Graph-2

The intersection point of the straight lines depicting the equations is the solution for the equations.

Can we find intersecting lines in all situations? In fact, lines on graphs for equations describing different conditions look very different. Let us understand what this means.

1. When the lines for equations intersect at a point then we say that the equations have a unique solution. The values of x and y at the intersection point is the solution of the equations.

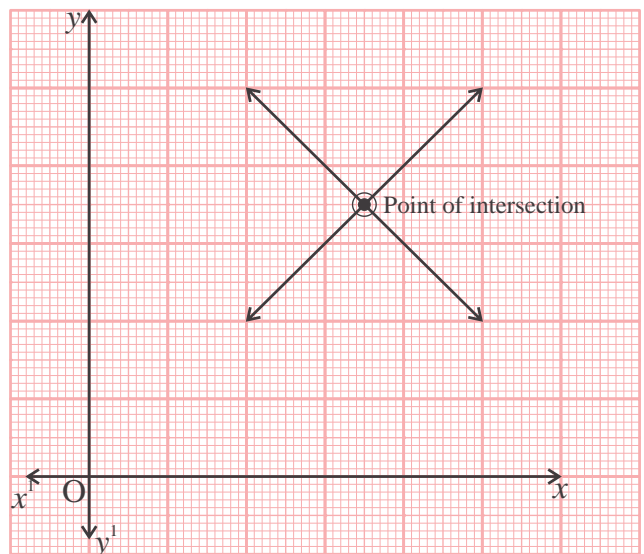

Graph-3

2. When the lines for equations are parallel then the two equations do not have any solution because the equations have no point in common.

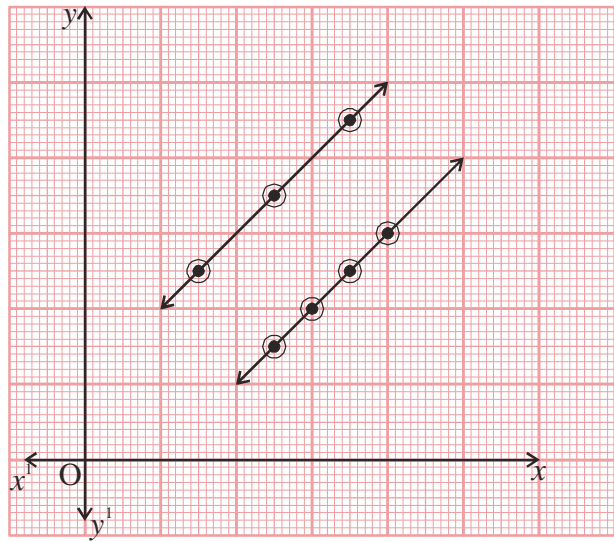

Graph-4

3. When the lines for the two equations are co-incident, i.e. they lie over one another, then the equations have infinite number of solutions because in this situation there are infinite points common to the two lines.

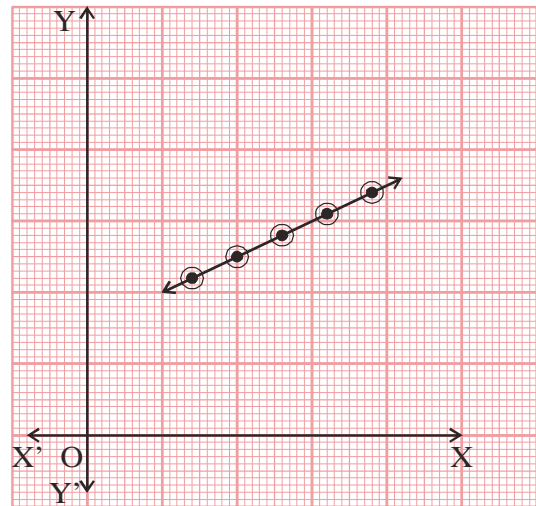

Graph-5

The properties of the lines depicting different equations help us understand day to day problems better.

Let us understand through some examples

how the properties of lines and graphs described above are helpful in daily-life problems.

Example:6. Kavita purchased 1 pencil and 2 erasers for Rs.4 and Savita bought 2 pencils and 4 erasers for Rs. 16. Can we use this information to find the price paid by Kavita and Savita for one pencil and one eraser?

Solution: Let us assume that the price of one pencil is Rs. x and the price of one eraser is Rs. y . Since, Kavita paid Rs. 4 for one pencil and two erasers we can show this using the following equation:

$$1 \times x + 2 \times y = 4$$

$$x + 2y = 4 \quad \dots\dots\dots(1)$$

Similarly, Savita paid Rs. 16 to buy 2 pencils and 4 erasers and this can be written in the form of an equation as shown below:

$$2 \times x + 4 \times y = 16$$

$$2x + 4y = 16 \quad \dots\dots\dots(2)$$

From equation (1)

$$x + 2y = 4$$

Or $2y = 4 - x$

$$y = \frac{4 - x}{2} \quad \dots\dots\dots(3)$$

Putting $x = 0, 1, 2, 3, \dots$ in equation (3) will give us corresponding values for y and we will write them in table - 1.

Table-1

x	0	1	2	3	4	5	6
y	2	1.5	1	0.5	0	-0.5	-1

Equation (2) can be re-written as follows:

$$\Rightarrow 2x + 4y = 16$$

$$\Rightarrow 2(x + 2y) = 16$$

$$\Rightarrow x + 2y = 8$$

$$\Rightarrow 2y = 8 - x$$

$$\Rightarrow y = \frac{8 - x}{2}$$

Putting $x = 0, 1, 2, 3, 4, 5$ and 6 in equation (4) will give us corresponding values $4, 3.5, 3, 2.5, 2, 1.5, 1$ respectively for y and we will write them in table - 2.

Table-2

x	0	1	2	3	4	5	6
y	4	3.5	3	2.5	2	1.5	1

Using the values in table - 1 and table - 2, we can draw the following graph:

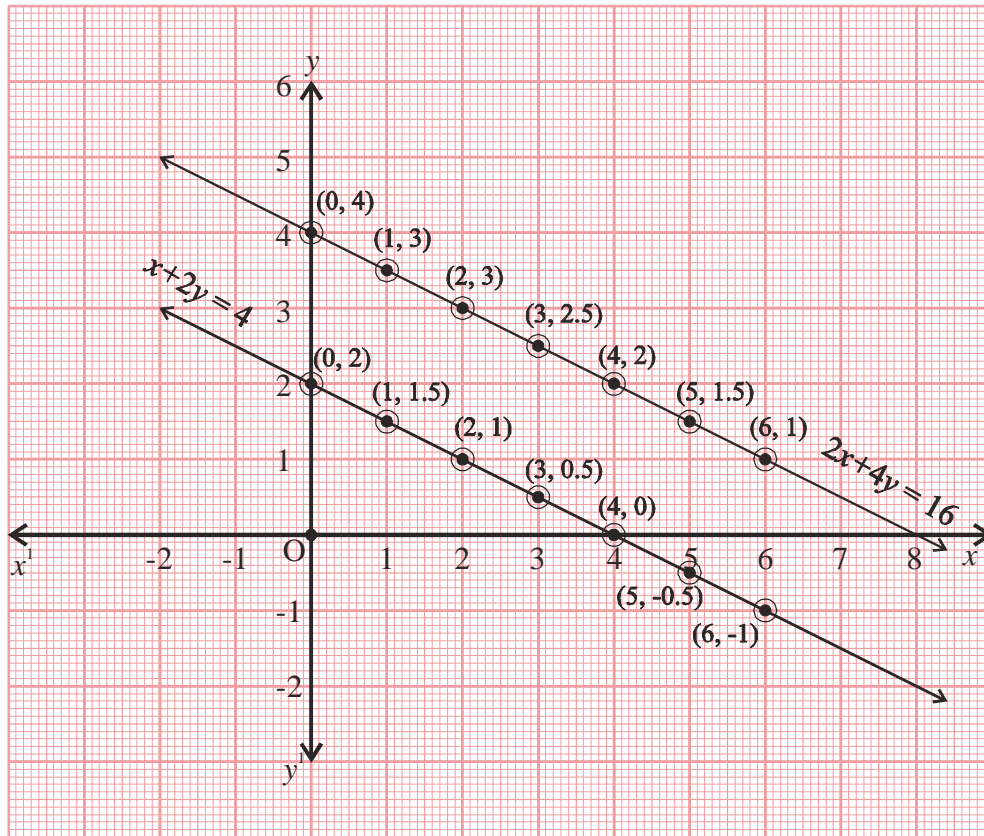

Graph-6

We see that we are getting two parallel lines for the equations then what will be the values for x and y ?

We can see that there is no point of intersection therefore the two equations do not have a unique solution. This means that the costs of pencil and eraser purchased by Savita and Kavita are different.

Example:7. A person purchased three chairs and two tables for Rs. 1200 and then paid Rs. 2400 for six chairs and two tables. Then, what is cost of one table and one chair?

Solution: Let the cost of one chair be Rs. x

And the cost of one table be Rs. y .

Then, the cost of three chairs and two tables is $3x + 2y$

According to the problem $3x + 2y = 1200$(1)

Similarly, the cost of six chairs and 4 tables is Rs. 2400.

$$\Rightarrow 6x + 4y = 2400$$

$$\Rightarrow 2(3x + 2y) = 2400$$

$$\Rightarrow (3x + 2y) = \frac{2400}{2}$$

$$\Rightarrow 3x + 2y = 1200 \dots\dots\dots(2)$$

Both the equations are identical and if we draw their graphs we will get coincident lines.

In both equations (1) and (2),

If $x = 100$ then $y = \frac{1200 - 3x}{2} = \frac{1200 - 3(100)}{2}$

$$y = \frac{900}{2} = 450$$

$x = 200$ then $y = \frac{1200 - 3(200)}{2} = \frac{1200 - 600}{2}$

$$y = \frac{600}{2} = 300$$

Similarly, we will find the corresponding values of y for different values of x and write then in the form of a table:

x	100	200	300	400	500	600
y	450	300	150	0	-150	-300

This table is common for both the equations therefore if we draw a graph using these values the two lines which we get will be coincident.

Clearly, the values of x and y in the two equations can be called the solutions of the equation system. Since x and y can have infinite values therefore the given system of equations can have infinite solution.

Since in the equation x and y stand for price of one chair and one table respectively therefore it can be said that there can be many possible prices for a chair and a table.

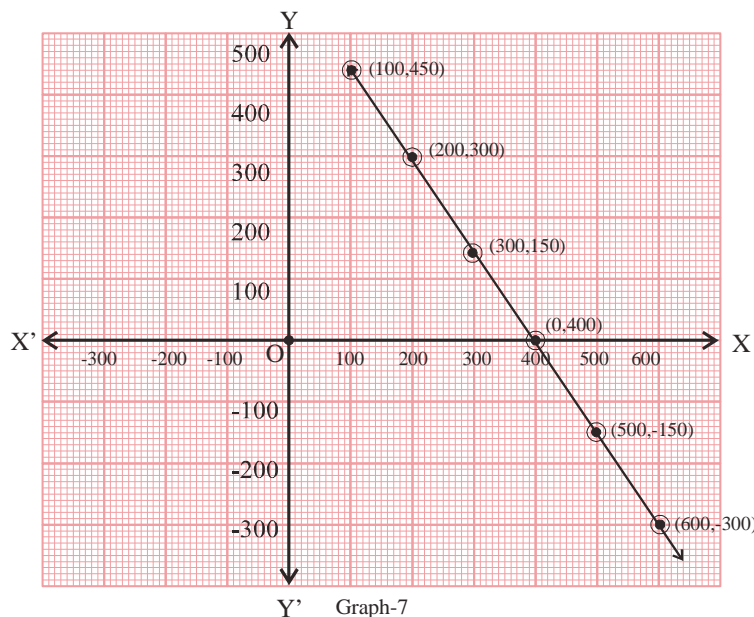

Example 8. Find the values of x and y for the system of equations depicted in the graph given below.

Solution:

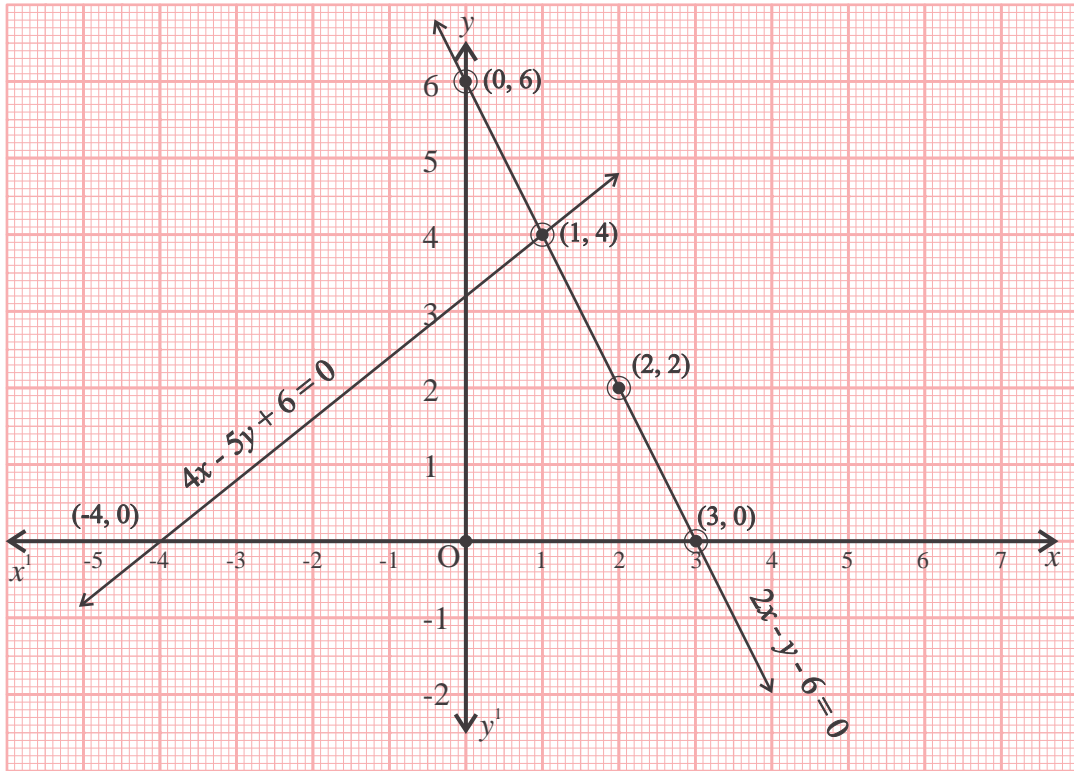

Graph-8

From the graph it can be seen clearly that the lines for the two equations intersect each other at point $(1, 4)$ and thus, the solution for this system of equation will be $x = 1, y = 4$.

Exercise-1



1. Write the following statements in the form of equations:
 - a. The cricket coach in a school purchased 3 bats and 6 balls for Rs. 3900. He bought a bat and two balls from the same shop for Rs. 1300.
 - b. The sum of two numbers is 16 and their difference is 8.
 - c. The cost of 2 kg apples and 1 kg grapes is Rs. 160 in a fruit shop. In the same shop, the cost of 4 kg apples and 2 kg grapes is Rs. 300.
 - d. Naresh said to his daughter that seven years ago my age was seven times your age and three years from now I will be three times as old as you.
 - e. A person travels 90 km by train and taxi to reach his office. The distance travelled by train is twice the distance travelled by taxi.

2. Look at the graphs for the given equations and try to find their solutions.

a. In Equations

$$3x + 2y - 12 = 0$$

$$x - y + 1 = 0$$

The solution is.....

And, therefore the values of x and y are

.....,

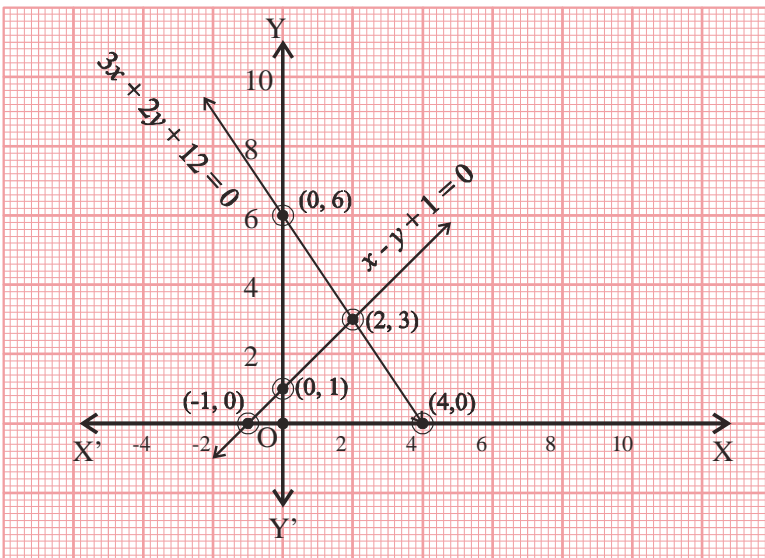

Graph-9

b. In Equations

$$3x + 6y = 15$$

$$x + 2y = 5$$

The solution is.....

And, therefore the values of x and y are

.....,

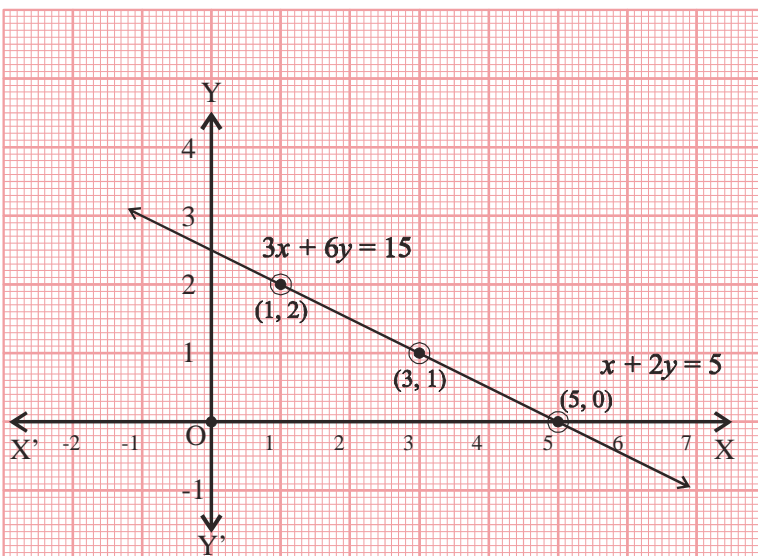

Graph-10

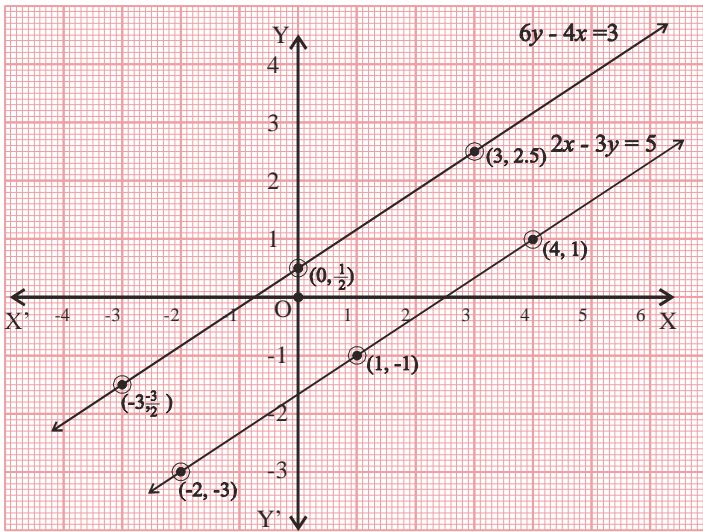

Graph-11

- c. In Equations
 $-4x + 6y = 3$
 $2x - 3y = 5$
 The solution is.....
 And, therefore the values of x and y are
,

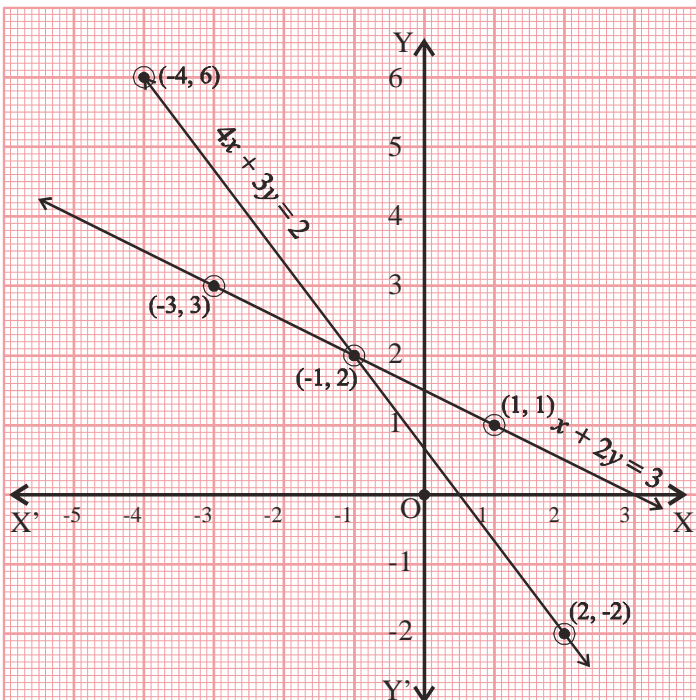

Graph-12

- d. In Equations
 $x + 2y = 3$
 $4x + 3y = 2$ में
 The solution is.....
 And, therefore the values of x and y are
,

Algebraic methods for solving equations

1. Substitution method

We have learnt how to find the solutions of equations in two variables using graphs. Now we will discuss some more methods to find solutions of linear equations in two variables. In

one method, we put the values of one equation in the second equation to convert it into an equation in one variable and then find its solution. We can understand this method through some examples.

Example-9. There are some rabbits and some birds in a small cave and the number of heads is 35 and the number of feet is 98. Find the number of birds and rabbits.

Solution: Let the number of rabbits = x
 And, the number of birds = y
 Number of heads of rabbits + number of heads of birds = 35

$$\therefore x + y = 35 \dots\dots\dots(1)$$

Number of feet of rabbits + number of feet of birds = 98

$$\therefore 4x + 2y = 98$$

$$2(2x + y) = 98$$

$$2x + y = \frac{98}{2}$$

$$2x + y = 49$$

$$y = 49 - 2x \dots\dots\dots(2)$$

Placing $y = 49 - 2x$ in equation (1)

$$x + 49 - 2x = 35$$

$$\Rightarrow -x + 49 = 35$$

$$\Rightarrow -x = 35 - 49$$

$$\Rightarrow -x = -14$$

$$\Rightarrow x = 14$$

Now, placing $x = 14$ in equation (2)

$$\Rightarrow y = 49 - 2x$$

$$\Rightarrow y = 49 - 2(14)$$

$$\Rightarrow y = 49 - 28$$

$$\Rightarrow y = 21$$

Clearly, the number of rabbits is 14 and the number of birds is 21.

2. Elimination method

In another method for solving equations, we sometimes add (or sometimes subtract) the two equations to reduce them to equations in one variables which can be solved. Let us see some examples where this method is used.

Example 10. Richa and Naina had some toffees. If Richa gives 30 toffees to Naina then Naina will have two times as many toffees as Richa. If Naina gives 10 toffees to Richa then Richa will have three times as many toffees as Naina. Find out how many toffees each of them has.

Solution: Let the number of toffees with Richa = x
 Let the number of toffees with Naina = y
 Now, if Richa gives 30 toffees to Naina
 Then, new number of toffees with Richa = $x - 30$
 And, new number of toffees with Naina = $y + 30$

$$\begin{aligned} \text{According to the question} \quad 2(x - 30) &= y + 30 \\ \Rightarrow 2x - 60 &= y + 30 \\ \Rightarrow 2x - y &= 30 + 60 \\ \Rightarrow 2x - y &= 90 \dots\dots\dots(1) \end{aligned}$$

But when Naina gives 10 toffees to Richa

Then, number of toffees with Richa = $x + 10$
 And number of toffees with Naina = $y - 10$

$$\begin{aligned} \text{According to the question} \quad x + 10 &= 3(y - 10) \\ \Rightarrow x + 10 &= 3y - 30 \\ \Rightarrow x - 3y &= -30 - 10 \\ \Rightarrow x - 3y &= -40 \dots\dots\dots(2) \end{aligned}$$

Now

$$\begin{aligned} 2x - y &= 90 \dots\dots\dots(1) \\ x - 3y &= -40 \dots\dots\dots(2) \end{aligned}$$

Are there any common coefficients for x and y in equations (1) and (2)?

No, x and y do not have any common coefficients. Then, let us see if adding or subtracting equations (1) from (2), will eliminate either x or y ? If there are some common coefficients for x or y then it is possible to eliminate one of them.

To get common coefficients, we will multiply both sides of equation (2) with 2, which is the coefficient of x in equation (1).

$$\begin{aligned} 2(x - 3y) &= -40 \times 2 \\ 2x - 6y &= -80 \dots\dots\dots(3) \end{aligned}$$

On subtracting equation (3) from equation (1),

$$\begin{aligned} \Rightarrow 2x - y - (2x - 6y) &= 90 - (-80) \\ \Rightarrow 2x - y - 2x + 6y &= 90 + 80 \\ \Rightarrow 5y &= 170 \\ \Rightarrow y &= \frac{170}{5} \\ \Rightarrow y &= 34 \end{aligned}$$

On putting the value of y in equation (1),

$$\begin{aligned} 2x - 34 &= 90 \\ \Rightarrow 2x &= 90 + 34 \\ \Rightarrow 2x &= 124 \\ \Rightarrow x &= \frac{124}{2} \\ \Rightarrow x &= 62 \end{aligned}$$

Clearly, Richa has 62 and Naina has 34 toffees.

Example:-11. The students of a class are standing in rows. If we remove 4 students from each row then we get one extra row but if 4 more students stand in each row then two less rows formed. Find the number of students in the class.

Solution: Let the number of rows = x
 And the number of students in each row = y

Then total number of students = number of rows X number of students in each row
 = xy

Now, if there are 4 less students in each row

Then, new number of students in each row = y - 4

And, new number rows = x + 4

Then, total number of students = (x + 4)(y - 4)

$$\begin{aligned} \Rightarrow xy &= xy - 4x + 4y - 16 \\ \Rightarrow xy - xy &= -4x + 4y - 16 \\ \Rightarrow 0 &= 4(-x + y - 4) \\ \Rightarrow -x + y - 4 &= 0 \\ \Rightarrow -x + y &= -4 \quad \dots\dots\dots(1) \end{aligned}$$

But when four additional students are standing in each row

Then, number of students in each row = y + 4

$$\begin{aligned}
 \text{And,} & \quad \text{number of rows} = x - 2 \\
 \text{Then,} & \quad \text{total number of students} = (x - 2)(y + 4) \\
 \Rightarrow & \quad xy = (x - 2)(y + 4) \\
 \Rightarrow & \quad xy = xy + 4x - 2y - 8 \\
 \Rightarrow & \quad xy - xy = 4x - 2y - 8 \\
 \Rightarrow & \quad 0 = 4x - 2y - 8 \\
 \Rightarrow & \quad 2(2x - y - 4) = 0 \\
 \Rightarrow & \quad 2x - y - 4 = 0 \\
 \Rightarrow & \quad 2x - y = 4 \quad \dots\dots\dots(2)
 \end{aligned}$$

The system of equations is:

$$\begin{aligned}
 -x + y &= 4 && \dots\dots\dots(1) \\
 2x - y &= 4 && \dots\dots\dots(2)
 \end{aligned}$$

Since, the coefficient of y is common and the signs are opposite in the system of equations, therefore y will be eliminated on adding the two equations.

$$\begin{aligned}
 -x + y + 2x - y &= 4 + 4 \\
 \Rightarrow x &= 8
 \end{aligned}$$

On putting value of x in equation (1)

$$\begin{aligned}
 \Rightarrow -8 + y &= 4 \\
 \Rightarrow y &= 4 + 8 \\
 \Rightarrow y &= 12
 \end{aligned}$$

The total number of students = $xy = 8 \times 12 = 96$.

We have discussed several methods to solve equations. You can use any method which you find easy and convenient.

Example 12. Ten years ago the sum of ages of Sunil and Vinay was one third the age of their father. If Sunil is 2 years younger than Vinay and the sum of their current ages is 14 less than their father's age. Find the present ages of Vinay, Sunil and their father.

Solution. Let Vinay's present age be = x years
 Sunil's present age = $x - 2$ years
 Their father's present age = y years
 Ten years ago, Vinay's age = $x - 10$
 And, Sunil's age = $(x - 2 - 10)$
 Their father's age = $(y - 10)$ years

$$\begin{aligned} \therefore (x - 10) + (x - 2 - 10) &= \frac{1}{3} \times (y - 10) \\ \Rightarrow x - 10 + x - 2 - 10 &= \frac{1}{3} (y - 10) \\ \Rightarrow 2x - 22 &= \frac{1}{3} (y - 10) \\ \Rightarrow 3(2x - 22) &= y - 10 \\ \Rightarrow 6x - 66 &= y - 10 \\ \Rightarrow 6x - y &= -10 + 66 \\ \Rightarrow 6x - y &= 56 \quad \dots\dots\dots(1) \end{aligned}$$

The sum of present ages of Sunil and Vinay is 14 less than their father's age.

$$\begin{aligned} \therefore x + x - 2 &= y - 14 \\ \Rightarrow 2x - 2 &= y - 14 \\ \Rightarrow 2x - y &= -14 + 2 \\ \Rightarrow 2x - y &= -12 \quad \dots\dots\dots(2) \end{aligned}$$

On subtracting equation (2) from equation (1),

$$\begin{aligned} 6x - y - (2x - y) &= 56 - (-12) \\ \Rightarrow 6x - y - 2x + y &= 68 \\ \Rightarrow 4x &= 68 \\ \Rightarrow x &= \frac{68}{4} \\ \Rightarrow x &= 17 \end{aligned}$$

On putting value of x in equation (1),

$$\begin{aligned} 6 \times 17 - y &= 56 \\ 102 - y &= 56 \\ y &= 102 - 56 \\ y &= 46 \end{aligned}$$

\therefore Present age of Vinay = 17 years
 Present age of Sunil = $17 - 2 = 15$ years
 Father's present age = y years = 46 years

A variety of questions are presented below where the different methods discussed have been used.

Example:13. Seven times of a two digit number is equal to 4 times of the number formed by reversing the digits. The sum of the two digits is 3. Find the numbers.

Solution. For the given two digit number, let the digit at the unit's place be x and that at the ten's place be y . Then the number is $(10x + y)$.

$$\begin{aligned} \therefore \quad \text{According to the question} \quad 7(10x + y) &= 4(10y + x) \\ \Rightarrow \quad 70x + 7y &= 40y + 4x \\ \Rightarrow \quad 70x - 4x - 40y + 7y &= 0 \\ \Rightarrow \quad 66x - 33y &= 0 \\ \Rightarrow \quad 33(2x - y) &= 0 \\ \Rightarrow \quad 2x - y &= 0 \quad \dots\dots\dots(1) \\ \text{and} \quad x + y &= 3 \quad \dots\dots\dots(2) \end{aligned}$$

On adding equations (1) and (2),

$$\begin{aligned} 2x - y + x + y &= 0 + 3 \\ \Rightarrow \quad 3x &= 3 \\ \Rightarrow \quad x &= \frac{3}{3} \\ \Rightarrow \quad x &= 1 \end{aligned}$$

On putting the value of x in equation (2)

$$\begin{aligned} \Rightarrow \quad x + y &= 3 \\ \Rightarrow \quad 1 + y &= 3 \\ \Rightarrow \quad y &= 3 - 1 \\ \Rightarrow \quad y &= 2 \end{aligned}$$

Therefore, the number is 12.

Example: 14. Find the values of the variables in the given equations.

$$2x - 5y = -8 \quad ;$$

$$x - 4y = -7$$

$$\begin{aligned} \text{Solution.} \quad \text{Equation} \quad 2x - 5y = -8 & \quad \dots\dots\dots(1) \\ x - 4y = -7 & \quad \dots\dots\dots(2) \end{aligned}$$

$$\text{From equation (2)} \quad x = -7 + 4y \quad \dots\dots\dots(3)$$

On putting this value of x in equation (1),

$$\begin{aligned} \Rightarrow 2(-7 + 4y) - 5y &= -8 \\ \Rightarrow -14 + 8y - 5y &= -8 \\ \Rightarrow 3y &= -8 + 14 \\ \Rightarrow 3y &= 6 \\ \Rightarrow y &= \frac{6}{3} = 2 \end{aligned}$$

On putting this value of y in equation (3),

$$\begin{aligned} \Rightarrow x &= -7 + 4y \\ \Rightarrow x &= -7 + 4(2) \\ \Rightarrow x &= -7 + 8 \\ \Rightarrow x &= 1 \end{aligned}$$

Therefore, $x = 1, y = 2$

Example:15. Solve the given equations.

$$41x - 17y = 99 ;$$

$$17x - 41y = 75.$$

Solution. Equation $41x - 17y = 99$ (1)
 $17x - 41y = 75$ (2)

On adding equations (1) and (2)

$$\begin{aligned} 41x - 17y + 17x - 41y &= 99 + 75 \\ \Rightarrow 58x - 58y &= 174 \\ \Rightarrow 58(x - y) &= 174 \\ \Rightarrow x - y &= \frac{174}{58} \\ \Rightarrow x - y &= 3 \end{aligned} \quad \text{.....(3)}$$

On subtracting equation (2) from equation (1)

$$\begin{aligned} 41x - 17y - (17x - 41y) &= 99 - 75 \\ \Rightarrow 41x - 17y - 17x + 41y &= 24 \\ \Rightarrow 24x + 24y &= 24 \\ \Rightarrow x + y &= \frac{24}{24} \\ \Rightarrow x + y &= 1 \end{aligned} \quad \text{.....(4)}$$

On adding equations (3) and (4),

$$\Rightarrow x - y + x + y = 3 + 1$$

$$\Rightarrow 2x = 4$$

$$\Rightarrow x = \frac{4}{2}$$

$$\Rightarrow x = 2$$

Putting $x = 2$ in equation (3)

$$\Rightarrow x - y = 3$$

$$\Rightarrow 2 - y = 3$$

$$\Rightarrow 2 - 3 = y$$

$$\Rightarrow y = -1$$

Here, $x = 2$ and $y = -1$.

Example:16. In $\triangle ABC$, $\angle A = x^\circ$, $\angle B = 3x^\circ$ and $\angle C = y^\circ$. If $3y^\circ - 5x^\circ = 30^\circ$ then prove that this is a right triangle.

Solution. The values of three angles in $\triangle ABC$ are respectively, $\angle A = x^\circ$, $\angle B = 3x^\circ$ and $\angle C = y^\circ$

\therefore The sum of interior angles of a triangle is 180°

$$\therefore \angle A + \angle B + \angle C = 180^\circ$$

On putting the values of $\angle A$, $\angle B$, $\angle C$

$$x^\circ + 3x^\circ + y^\circ = 180^\circ$$

$$4x^\circ + y^\circ = 180^\circ$$

$$y^\circ = 180^\circ - 4x^\circ \quad \dots\dots\dots(1)$$

Given $3y^\circ - 5x^\circ = 30^\circ \quad \dots\dots\dots(2)$

Putting the value of y from equation (1) in equation (2)

$$\Rightarrow 3 [180^\circ - 4x^\circ] - 5x^\circ = 30^\circ$$

$$\Rightarrow 3 \times 180^\circ - 3 \times 4x^\circ - 5x^\circ = 30^\circ$$

$$\Rightarrow 540^\circ - 12x^\circ - 5x^\circ = 30^\circ$$

$$\Rightarrow -17x^\circ = 30^\circ - 540^\circ$$

$$\Rightarrow -17x^\circ = -510^\circ$$

$$\Rightarrow x^\circ = \frac{510^\circ}{17^\circ}$$

$$x^\circ = 30^\circ$$

When in a system of equations, the coefficients of different variables are same, then we get new equations by first adding the two equations and then subtracting them.

Putting the value of x in equation (1)

$$\begin{aligned} & y^\circ = 180^\circ - 4(30^\circ) \\ \Rightarrow & y^\circ = 180^\circ - 120^\circ \\ \Rightarrow & y^\circ = 60^\circ \\ \therefore & \angle A = x^\circ = 30^\circ \\ & \angle B = 3x^\circ = 3 \times 30^\circ = 90^\circ \\ & \angle C = y^\circ = 60^\circ \end{aligned}$$

Clearly, of the three angles in $\triangle ABC$, one is 90° and the other two are acute angles measuring 30° and 60° .

Therefore, the given $\triangle ABC$ is a right angle triangle.

Example:17. A boat goes 30 km upstream and 44 km downstream in 10 hours. In 13 hours, it can go 40 km upstream and 55 km down-stream. Determine the speed of the stream and that of the boat in still water.

Solution: Let the speed of boat downstream (in the direction of flow of water) = x km/h

And let the speed of boat upstream (opposite to the direction of flow of water) = y km/h

Time taken to travel 44 km downstream = distance/speed

$$= \frac{44}{x} \text{ hours}$$

Time taken to travel 30 km upstream = $\frac{30}{y}$ hours

\therefore According to the question,

Time taken to go 30 km upstream and 44 km downstream = 10 hours

$$\therefore \frac{44}{x} + \frac{30}{y} = 10 \quad \dots\dots\dots(1)$$

Since the time taken to go 40 km upstream and 55 km downstream = 13 hours

$$\therefore \frac{55}{x} + \frac{40}{y} = 13 \quad \dots\dots\dots(2)$$

Putting $(1/x) = u$ and $(1/y) = v$ in equations (1) and (2), gives us equations (3) and (4).

$$\begin{aligned} 44u + 30v &= 10 \\ 22u + 15v &= 5 \quad \dots\dots\dots(3) \end{aligned} \quad \left\{ \because \text{Speed} = \frac{\text{Distance}}{\text{Time}} \right\}$$

$$\text{and } 55u + 40v = 13 \quad \dots\dots\dots(4)$$

Now, on multiplying equation (3) by 55 and equation (4) by 22

$$\begin{array}{r} 1210u + 825v = 275 \\ -1210u - 880v = -286 \\ \hline -55v = -11 \end{array}$$

$$v = \frac{-11}{-55}$$

$$v = \frac{1}{5} \quad \therefore y = 5$$

On putting value of v in equation (3)

$$22u + 15 \times \frac{1}{5} = 5$$

$$22u + 3 = 5$$

$$22u = 5 - 3$$

$$u = \frac{2}{22}$$

$$u = \frac{1}{11} \quad \therefore x = 11$$

$$\Rightarrow x = 11 \quad \Rightarrow y = 5$$

Therefore, the speed of boat downstream = 11 km/h and the speed of boat upstream = 5 km/h.

Think and Discuss



Solve the above system of equations using different methods. Discuss whether the solutions obtained using the different methods are same or not?

$$2x + 5y = 1$$

$$2x + 3y = 3$$

Exercises 2



1. Check whether values of x and y given in 'A' and 'B' are solutions of given equations.

(A) $x = 2, y = 5$ (B) $x = -1, y = 3$

(i) $x + y = 7$ (ii) $2x + 5y = 13$

(iii) $2x - 3y = -11$ (iv) $5x + 3y = 4$

2. Check which one of "A" or "B" is a solution for given equations.

(A) $x = 3, y = -1$ (B) $x = \frac{1}{2}, y = \frac{1}{3}$

(i) $2x + 5y = 1;$ (ii) $x + y = 5xy;$

$2x + 3y = 3.$ $3x + 2y = 13xy.$

(iii) $2x - \frac{3}{y} = 9;$ (iv) $2x + 5y = \frac{8}{3};$

$3x + \frac{7}{y} = 2$ $3x - 2y = \frac{5}{6}$

3. Solve the given equations. You can use whichever method you want.

(i) $x - y = -1;$ (ii) $x - 2y = 5;$

$3x - 2y = 12.$ $2x - 4y = 6$

(iii) $x + y = 6;$ (iv) $5x - 8y = -1$

$x = y + 2.$ $3x - \frac{24}{5}y + \frac{3}{5} = 0$

(v) $3x - 4y - 1 = 0;$ (vi) $x + 2y = 8;$

$2x - \frac{8}{3}y + 5 = 0$ $2x + 4y = 16$

4. Solve the following system of equations for the given variables.

(i) $x + y = 7;$ (ii) $2x + y = 8;$

$x - y = -1.$ $x - 2y = -1$

(iii) $4x + 3y = 5;$ (iv) $\sqrt{7}x + \sqrt{11}y = 0;$

$2x - y = 2$ $\sqrt{3}x - \sqrt{5}y = 0$

5. The cost of 15 kg tea and 17 kg coffee is Rs. 183 and the cost of 25 kg tea and 13 kg coffee is Rs. 213. What will be the cost of 7 kg tea and 1 kg coffee?

6. A person owns some pigeons and cows. The number of legs of these animals is

- 180 and the total number of eyes is 120. How many cows and pigeons does the person own?
7. A bag has 50 paisa and 25 paisa coins. The total number of coins is 94 and their value is Rs. 29.75. Find the number of 50 paisa and 25 paisa coins.
8. The sum of two numbers is 25. The sum of their reciprocals is $\frac{1}{4}$. Find the two numbers.
- [Hint: $(x - y)^2 = (x + y)^2 - 4xy$]
9. The difference of two numbers is 14 and the difference in their squares is 448. Find the numbers.
- [Hint: $x^2 - y^2 = (x + y)(x - y)$]
10. The product of two numbers is 45 and their sum is 14. Find the two numbers.
11. 5 years ago I was three times as old as my daughter. Ten years hence I will be twice as old as my daughter. Find my present age and my daughter's present age.
12. The distance between two cities, A and B, is 70 km. Two cars start moving from A and B respectively. If they move in the same direction, they will meet in 7 hours and if they move towards each other they will meet in 1 hour. Find the speeds of both the cars.
13. Some students are sitting in classroom A and B in a school. When 10 students from room A are sent to room B, the number of students in both rooms becomes equal. When 20 students from room B are sent to room A, then the number of students in room A becomes twice that in room B. Find the number of students in each room.
14. If the length of a rectangle is decreased by 5 units and its breadth increased by 2 units then the area of the rectangle decreases by 80 square units. If its length is increased by 10 units and its breadth decreased by 5 units then the area of the rectangle increases by 50 square units. Find the original length and breadth of the rectangle.

Determining the type of solution by looking at the system of equations

Can you tell whether we can solve a system of equations or not simply by looking at it? Yes, it is possible but to do this we will need to find the relation between the coefficients of the variable terms and the fixed terms in the system of equations.

Look at the give system of equations:

$$2x + 3y = 7 \quad \dots\dots\dots(1)$$

$$6x + 9y = 11 \quad \dots\dots\dots(2)$$

In equation (1), the coefficient of x is 2, the coefficient of y is 3 and 7 is the constant term. If 2, 3 and 7 are denoted by $a_1, b_1,$ and c_1 respectively and the coefficients and constant terms in equation (2) are denoted by $a_2, b_2,$ and c_2 respectively then the system of equation can be written as follows:

$$a_1x + b_1y = c_1$$

$$a_2x + b_2y = c_2$$

We can write other systems of equations in the same way.

The table below shows the relation between the ratio of the coefficients of like variables and constants in a system of equations. We can draw some conclusions by looking at these ratios.

S.No.	Relation between coefficients of like terms	Solution of system of equations	Geometrical meaning
1.	(condition) $\frac{a_1}{a_2} \neq \frac{b_1}{b_2}$	A unique solution is obtained	The system of equations is depicted by two intersecting lines.
2.	$\frac{a_1}{a_2} = \frac{b_1}{b_2} \neq \frac{c_1}{c_2}$	There is no solution	The system of equations is depicted by two parallel lines
3.	$\frac{a_1}{a_2} = \frac{b_1}{b_2} = \frac{c_1}{c_2}$	There are infinite solutions	The system of equations is depicted by coincident lines

Let us understand about solutions of equations using these relations.

Example:18. What type of solutions do the following equations have? Find out.

$$3x + 5y = 12 \quad \dots\dots\dots(1)$$

$$4x + 2y = 5 \quad \dots\dots\dots(2)$$

Solution: In $3x + 5y = 12$, $a_1 = 3$, $b_1 = 5$, $c_1 = 12$

$$4x + 2y = 5 \quad a_2 = 4, b_2 = 2, c_2 = 5$$

\therefore Here $\frac{a_1}{a_2} \neq \frac{b_1}{b_2} \quad \therefore$ The equations have a unique solution.

Example:19. Find the solutions of $5x + 3y = 12$

$$\text{and } 15x + 9y = 15$$

Solution: In $5x + 3y = 12$, $a_1 = 5$, $b_1 = 3$, $c_1 = 12$

$$\text{and in } 15x + 9y = 15, \quad a_2 = 15, b_2 = 9, c_2 = 15$$

$$\frac{a_1}{a_2} = \frac{5}{15}, \frac{b_1}{b_2} = \frac{3}{9}, \frac{c_1}{c_2} = \frac{12}{15}$$

$$\frac{a_1}{a_2} = \frac{1}{3}, \frac{b_1}{b_2} = \frac{1}{3}, \frac{c_1}{c_2} = \frac{4}{5}$$

We find that $\frac{a_1}{a_2} = \frac{b_1}{b_2} \neq \frac{c_1}{c_2}$

\therefore The equations have no solution.

Finding the value of unknown coefficient of variables

Example:20. Find the solution of $15x - 3y = 14$

$$\text{and } 60x - 12y = 56$$

Solution: In $15x - 3y = 14$, $a_1 = 15$, $b_1 = -3$, $c_1 = 14$

$$\text{In } 60x - 12y = 56, \quad a_2 = 60, b_2 = -12, c_2 = 56$$

$$\text{Here, } \frac{a_1}{a_2} = \frac{15}{60} = \frac{1}{4}, \quad \frac{b_1}{b_2} = \frac{-3}{-12} = \frac{1}{4}, \quad \frac{c_1}{c_2} = \frac{14}{56} = \frac{1}{4}$$

$$\text{Clearly } \frac{a_1}{a_2} = \frac{b_1}{b_2} = \frac{c_1}{c_2}$$

\therefore the equations have infinite solutions.

Do this

Complete the following table:



S.No.	System of equations	Ratio of coefficients of x	Ratio of coefficients of y	Ratio of constant terms	Relation between ratios	Solution of equations	Geometrical interpretations
1.	$2x-3y=1$ $2x-4y=-4$	$\frac{a_1}{a_2} = \frac{2}{2} = 1$	$\frac{b_1}{b_2} = \frac{-3}{-4} = \frac{3}{4}$	$\frac{c_1}{c_2} = \frac{1}{-4} = -\frac{1}{4}$	$\frac{a_1}{a_2} \neq \frac{b_1}{b_2}$	Unique solution	Two intersecting lines
2.	$x+2y=5$ $2x-3y=-4$
3.	$4x-5y=3$ $5x-4y=5$
4.	$2x+3y=5$ $-4x-6y=8$
5.	$3x-4y=1$ $6x-8y=-15$
6.	$x+y=4$ $2x+2y=8$
7.	$5x-6y=4$ $10x-12y=8$

Finding the value of unknown coefficient

We saw different situations and different methods for solving systems of equations. However, we knew the coefficients of the variables in these cases. Can we find the solution if one of the coefficients is unknown and the system is as follows:

$$2x + 3y - 5 = 0;$$

$$kx - 6y - 8 = 0.$$

Can we still find the values of x, y and k in such a situation?

Example:21. For what value of k will the system of equations have a unique solution?

$$x - ky = 2, \quad 3x + 2y = -5$$

Solution: In the given system of equations:

$$x - ky - 2 = 0, \quad 3x + 2y + 5 = 0$$

$$\text{Here, } a_1 = 1, \quad b_1 = -k, \quad c_1 = -2$$

$$a_2 = 3, \quad b_2 = 2, \quad c_2 = 5$$

We are told that the equations have a unique solution.

$$\text{Therefore, } \frac{a_1}{a_2} \neq \frac{b_1}{b_2} = \frac{c_1}{c_2}$$

$$\Rightarrow \frac{1}{3} \neq \frac{-k}{2}$$

$$\Rightarrow \frac{2}{-3} \neq k$$

$$\Rightarrow k \neq -\frac{2}{3}$$

Except for $k = -\frac{2}{3}$, the system will have a unique solution for all real values of k .

Example:22. Find the value of k for which the given system of equations has infinite solutions.

$$(k - 3)x + 3y = k; \quad kx + ky = 12$$

Solution. System of equations is

$$(k-3)x + 3y = k; \quad kx + ky = 12$$

$$a_1 = k-3, \quad b_1 = 3, \quad c_1 = k$$

$$a_2 = k, \quad b_2 = k, \quad c_2 = 12$$

Since the system of equations has infinite solutions

$$\text{Therefore, from } \frac{a_1}{a_2} = \frac{b_1}{b_2} = \frac{c_1}{c_2}$$

$$\frac{k-3}{k} = \frac{3}{k} = \frac{+k}{+12}$$

$$\begin{aligned} \Rightarrow \frac{k-3}{k} &= \frac{3}{k} & \dots\dots(1) & \quad \frac{3}{k} = \frac{k}{12} & \dots\dots(2) & \quad \frac{k-3}{k} = \frac{k}{12} & \dots\dots(3) \\ \Rightarrow k-3 &= 3 & & \Rightarrow k^2 = 36 & & \Rightarrow k^2 = 12k - 36 \\ \Rightarrow k &= 3+3 & & \Rightarrow k = \sqrt{36} & & \Rightarrow k^2 - 12k + 36 = 0 \\ \Rightarrow k &= 6 & & \Rightarrow k = \pm 6 & & \Rightarrow k - 6k - 6k + 36 = 0 \\ & & & & & \Rightarrow k(k-6) - 6(k-6) = 0 \\ & & & & & \Rightarrow (k-6)(k-6) = 0 \\ & & & & & k = 6 \end{aligned}$$

Only that value of k is valid which satisfies all equations. Here, 6 is such a value therefore $k = 6$.

Exercise-3

1. Show that the given system of equations has a unique solution.

$$3x + 5y = 12$$

$$5x + 3y = 4$$

2. Show that the given system of equations has infinite solutions.

$$2x - 3y = 5;$$

$$6x - 9y = 15$$

3. Find the value of k for which the given systems of equations have no solution.

(i) $8x + 5y = 9;$ $kx + 10y = 15$

(ii) $kx + 3y = 3;$ $12x + ky = 6$

(iii) $kx - 5y = 2;$ $6x + 2y = 7$

4. Find the value of k for which the given systems of equations have a unique solution.

(i) $kx + 2y = 5;$ $3x + y = 1$

(ii) $x - 2y = 3;$ $3x + ky = 1$

(iii) $kx + 3y = k - 3;$ $12x + ky = k$

(iv) $4x - 5y = k;$ $2x - 3y = 12$

5. Find the value of k for which the given systems of equations have infinite solutions.

(i) $2x + 3y = 7;$

$$(k-1)x + (k+2)y = 3k$$



(ii) $kx + 2y - 4 = 0$; $5x - 3y + 6 = 0$

(iii) $3x + ky = 7$; $2x - 5y = 1$

(iv) $kx - 5y = 2$; $2x - 3y = 12$

6. If $x = 2$; $y = 4$ then find the value of p in $7x - 4y = p$.
7. If the straight line $2x - ky = 9$ passes through $(1, -1)$, then find the value of k .
8. Test whether the following system of equations has a unique solution, infinite solution, or no solutions. If it has a unique solution then find the values of x and y .

$$4x + 7y = 18$$

$$2x + y = 4$$

Making statements from equations

So far we formulated equations for conditions derived from different statements and then found the values of variables. But can we write statements to describe given equations?

Come, let us write the following equations in the form of statements.

$$x + y = 45 \quad \dots\dots\dots(1)$$

$$x - y = 13 \quad \dots\dots\dots(2)$$

If we say that x is one number and y is another number then equations (1) and (2) can be written as follows:

The sum of two numbers is 45 and their difference is 13. Find the two numbers. Or, the cost of one book is x and the cost of one copy is y . The sum of their costs is 45 and the difference in their costs is 13. Can you find the cost of one book and one copy?

Can we form more statements from these equations? Make two more such statements.

Example 23 Write the following in the form of a statement.

$$\frac{x-1}{y} = \frac{1}{2} \quad \dots\dots\dots(1)$$

$$\frac{x}{y+3} = \frac{3}{2} \quad \dots\dots\dots(2)$$

Solution: If x/y is a fraction where the numerator is x and the denominator is y then the equations given above can be written in the form of the following statement:

"If 1 is subtracted from the numerator of a fraction then it becomes equal to $\frac{1}{2}$ and if 3 is added to the denominator, we get $\frac{3}{2}$."

There are many ways possible to write a given system of equations in the form of statements. The system given above can also be written in the form of other statements.

Write the given system of equations in the form of statements.

(i) $x + y = 60$
 $x = 3y$

(ii) $x + y = 5$
 $xy = 6$



What we have learnt

1. The graphs of equations in first degree in two variables are always straight lines and therefore equations in first degree in two variables are known as linear equations.
2. The graph of a pair of linear equations in two variables is represented by two lines. If the lines intersect at a point, then that point gives the unique solution of the two equations.
3. If the graph of a pair of linear equations in two variables is represented by two parallel lines, then the pair of equations has no solution.
4. If the graph of a pair of linear equations in two variables is represented by two coincident lines, then the pair of equations has infinite solutions.
5. Linear equations in the same two variables can be written as follows:

$$a_1x + b_1y = c_1$$

$$a_2x + b_2y = c_2$$

In the above equations, if

(i) $\frac{a_1}{a_2} = \frac{b_1}{b_2} \neq \frac{c_1}{c_2}$ Then lines are parallel and the pair of equations has no solution.

(ii) $\frac{a_1}{a_2} \neq \frac{b_1}{b_2}$ Then lines are intersecting and the pair of equations has unique solution.

(iii) $\frac{a_1}{a_2} = \frac{b_1}{b_2} = \frac{c_1}{c_2}$ Then lines are coincident and the pair of equations has infinite solutions.



ANSWER KEY

Exercise-1

1. (i) $3x + 6y = 3900$ (ii) $x + y = 16$ (iii) $2x + y = 160$
 $x + 2y = 1300$ $x - y = 8$ $4x + 2y = 300$
 (iv) $x - 7y + 42 = 0$ (v) $x + y = 90$
 $x - 3y - 6 = 0$ $x = 2y$
2. (a) $x = 2, y = 3$ (b) infinite solutions
 (c) no solution (d) $x = -1, y = 2$

Exercise-2

1. (i) (a) (ii) (b) (iii) (a), (b) (iv) (b)
2. (i) (a) (ii) (b) (iii) (a) (iv) (b)
3. (i) $x = 14, y = 15$ unique solution
 (ii) no solution, parallel lines
 (iii) $x = 4, y = 2$, a unique solution
 (iv) infinite solutions, coincident lines
 (v) no solution, parallel lines
 (vi) infinite solutions, coincident lines
4. (i) $x = 3, y = 4$ (ii) $x = 3, y = 2$
 (iii) $x = 1.1, y = 0.2$ (iv) $x = 0, y = 0$
5. ₹43.80
6. Number of cows = 30, Number of pigeons = 30
7. Number of 25 paise coins = 69, Number of 50 paise coins = 25
8. Numbers = 20, 5
9. Numbers = 23, 9
10. Numbers = 9, 5
11. My age = 50 years, son's age = 20 years
12. 40 km/h, 30 km/h,
13. 100, 40
14. 40 units, 30 units

Exercise-3

3. (i) $k = 16$ (ii) $k = -6$ (iii) $k = -15$
4. (i) $k \neq 6$ (ii) $k \neq -6$ (iii) $k \neq \pm 6$
 (iv) $k \neq \frac{10}{3}$
5. (i) $k = 7^3$ (ii) $k = \frac{-10}{3}$
 (iii) k has no value (iv) $k = 24^3$
6. $p = -2$
7. $k = 7$
8. has a unique solution $x = 1, y = 2$



Quadratic Equation In One Variable

Introduction

A person has some land and she wants to make a garden of area 800 square meters in one part such that length of the garden is twice its breadth. What should be the length and breadth of the garden?

If breadth of garden is taken as x meter then its length will be $2x$ meter.

Since garden is rectangular,

So, area of garden = length of garden \times breadth of garden

$$800 = 2x \cdot x$$

$$\frac{800}{2} = x^2$$

Or

$$\text{Or} \quad x^2 = 400$$

$$\text{Or} \quad x^2 = 20^2$$

$$\text{Or} \quad x^2 - 20^2 = 0 \quad \dots(i)$$

Those values of x for which both sides of equation (i) are equal, give us the breadth of the garden.

Once we know the breadth, then we can also find length.

Writing a Problem in Algebraic Form

We saw above that we can find the value of x from $x^2 - 20^2 = 0$. This equation is actually the algebraic description of the conditions given in the problem.

Let us discuss some more situations and look at their algebraic representations.

Naresh wants to make a garden bed (*kyari*) in front of his house. The garden bed is in the shape of a right-angled triangle of area 500 square meter, in which he wants the length of the base of the triangle to be 30 meter longer than its perpendicular height.

To find the size of the garden-bed, we should take its perpendicular as x meter and base as $x + 30$ meter.

Since area of right angle triangle = $\frac{1}{2} \times$ length of perpendicular \times length of base

$$\Rightarrow 500 = \frac{1}{2} \times x(x + 30)$$

$$\Rightarrow 500 \times 2 = x^2 + 30x$$

$$\Rightarrow x^2 + 30x - 1000 = 0 \quad \dots (ii)$$

Equation (ii) is algebraic representation of our question and the values of x for which both sides of equation (ii) become equal give us the perpendicular height of the right-angle flower bed.

Quadratic Equations:- The maximum degree of x is 2 in both of the above algebraic representations. If this quadratic polynomial is included we get an algebraic equation in one variable which can be solved to get the solution. Now, we consider some more examples of the same type.

Think about the following statement:-

The product of two consecutive numbers is zero.

If first number is x , then second number will be $x + 1$.

$$\therefore x(x + 1) = 0$$

$$x^2 + x = 0 \quad \dots (iii)$$

In each of the equations (i), (ii), (iii) there is only one variable and their maximum degree is two. In each of these equations, there necessarily exist one such term whose degree is two. Thus, all these are quadratic equations in one variable.

You know that $ax^2 + bx + c$ is a two degree polynomial in one variable (where a, b, c are real numbers and $a \neq 0$). It is known as quadratic polynomial. If we equate this quadratic polynomial equal zero it becomes a quadratic equation.

That is, $ax^2 + bx + c = 0$

Because there is only one variable in the equation and maximum degree of the variable is two, so it is called a quadratic polynomial. This is the standard form of a quadratic equation, also known as square equation.

Some more quadratic equations are given below:-

(i) $x^2 - 2x = 0$

(ii) $(x + 1)(x + 2) = 0$

(iii) $x^2 = 0$

(iv) $x^2 - 9 = 0$

(v) $z^2 + 3 = 0$

(vi) $x^2 - \sqrt{5}x + 6 = 0$

(vii) $3y^2 + 6y + 6 = 0$

(viii) $(x - 2)^2 = 0$

(ix) $3m - 2m^2 + 5 = 0$

$x^2 - 5\sqrt{x} + 3 = 0$ is not a quadratic (square) equation because left hand side of this equation is not a polynomial.

Try These

Select quadratic (square) equations in one variable from the following-

(i) $x^2 - 3x = 0$

(ii) $-3x^2 - 2^2 = 0$

(iii) $x + 2 = 0$

(iv) $x^2 + y = 9$

(v) $x^2 + 9 = 0$

(vi) $x + 5y = 0$

(vii) $(x-1)(x+2) = 0$

(viii) $x^2 + 2\sqrt{x} - 1 = 0$

(ix) $(x-3)^2 = 0$

(x) $x(x-5) = 0$

(xi) $x^2 + \sqrt{5}x + 3 = 0$

(xii) $y^2 - z^2 + 3 = 0$

(xiii) $x^2 - 3\sqrt{x} + 2 = 0$

(xiv) $x^2 - \sqrt{3}x + 2 = 0$

(xv) $(x+1)(x+5) = 0$

Exercise - 1

1. Select square equations from the following equations:-

(i) $x^2 + 3x - 2 = 0$

(ii) $x^2 + \frac{1}{x} = 1$

(iii) $9x^2 - 100x - 20 = 0$

(iv) $x^2 - 3\sqrt{x} + 2 = 0$

(v) $x - \frac{2}{x} = -x$

(vi) $\sqrt{5}x^2 - 3x + \frac{1}{2} = 0$

(vii) $x^2 - 10x = 0$

(viii) $x + y = 10$

(ix) $x + 5 = 7$

(x) $x(x-8) = 0$

Roots of Quadratic Equation

$p(x) = x^2 - 3x + 2$ is a quadratic polynomial. Zeroes of this polynomial are those value of x for which $p(x)$ will be zero. To find the zeroes we have to find factors of $x^2 - 3x + 2$.

$$\begin{aligned} x^2 - 3x + 2 &= x^2 - 2x - x + 2 \\ &= (x^2 - 2x) - 1(x - 2) \\ &= x(x - 2) - 1(x - 2) \\ &= (x - 2)(x - 1) \end{aligned}$$

Value of the polynomial $x^2 - 3x + 2$ will be zero if $(x - 2)(x - 1) = 0$

$$\begin{aligned} \Rightarrow & (x-2) = 0 & \text{Or} & (x-1) = 0 \\ \Rightarrow & x-2 = 0 & \text{Or} & x-1 = 0 \\ & \therefore x = 2 & \text{Or} & x = 1 \end{aligned}$$

So 2 and 1 are zeroes of polynomial $x^2 - 3x + 2$.

Now, let us find such values of x in square equation $x^2 - 3x + 2 = 0$ for which both sides of the equation will be equal. We call the values roots of the equation.

$$\begin{aligned} & x^2 - 3x + 2 = 0 \\ & (x-2)(x-1) = 0 \\ \Rightarrow & (x-2) = 0 & \text{Or} & (x-1) = 0 \\ \Rightarrow & x-2 = 0 & \text{Or} & x-1 = 0 \\ & \therefore x = 2 & \text{Or} & x = 1 \end{aligned}$$

Here, we find that the equation is satisfied when $x = 2, 1$. The same values of x are also zeroes of polynomial $x^2 - 3x + 2$. So we can say that zeroes of the polynomial are roots of the equation made by its factors.

How to find whether given values are roots of polynomial or not?

It is very easy to know whether a given value is root of a square equation or not. If we put a value in an equation and both sides of the equation become equal then these values are roots of the equation, otherwise not.

Let us learn to verify roots with the help of some examples.

Example-1. Verify whether $x = 1$ and $x = -1$ are roots of the square polynomial $x^2 - x + 1 = 0$ or not?

Solution : In the given equation $x^2 - x + 1 = 0$ left hand side is $x^2 - x + 1$ and right hand side is 0. On putting $x = 1$ in the left hand side-

$$\begin{aligned} & = 1^2 - 1 + 1 \\ & = 1 \end{aligned}$$

Clearly, LHS \neq RHS

So, $x = 1$, is not a zero of the given square polynomial.

Similarly, on putting $x = -1$

$$\begin{aligned} & = (-1)^2 - (-1) + 1 \\ & = 1 + 1 + 1 \\ & = 3 \end{aligned}$$

Clearly, LHS \neq RHS

So $x = -1$ is not a root of the given square polynomial $x^2 - x + 1 = 0$.

Example-2. Verify whether $x = 2, x = 3$ are roots of the square equation $x^2 - 5x + 6 = 0$ or not?

Solution : In given equation $x^2 - 5x + 6 = 0$ left hand side is $x^2 - 5x + 6$ and right hand side is 0. On putting $x = 2$ in LHS

$$\begin{aligned} & x^2 - 5x + 6 \\ &= (2)^2 - 5(2) + 6 \\ &= 4 - 10 + 6 \\ &= 0 \end{aligned}$$

Clearly, LHS = RHS

Similarly, on putting $x = 3$

$$\begin{aligned} &= (3)^2 - 5(3) + 6 \\ &= 9 - 15 + 6 \\ &= 0 \end{aligned}$$

Clearly, LHS = RHS

Thus $x = 2, x = 3$ are roots of equation $x^2 - 5x + 6 = 0$.

Try These

Verify whether given values of x are roots of the equation or not

(i) $x^2 + 6x + 5 = 0$; $x = -5, x = -1$

(ii) $9x^2 - 3x - 2 = 0$; $x = \frac{2}{3}, x = -\frac{1}{3}$

(iii) $x^2 + x + 1 = 0$; $x = 0, x = 1$

Methods of Solving Quadratic Equations

So far we have looked at how make square equations. Now we will discuss the methods of solving them.

$x^2 - 7x = 0$ is a square equation.

Can we determine the value of x in the given equation?

$$\begin{aligned} \therefore x^2 - 7x &= 0 \\ \Rightarrow x(x-7) &= 0 \\ \Rightarrow x=0 \quad \text{Or} \quad x-7 &= 0 \\ \text{Then, } x=0 \quad \text{Or} \quad x &= 7 \end{aligned}$$

Since the values of x satisfy the given equation, so these will be the solution of the equation $x^2 - 7x = 0$.

$$\begin{aligned} \text{Similarly, let us try to solve } (x-2)(x+1) &= 0 \\ \Rightarrow x+1=0 \quad \text{Or} \quad x-2 &= 0 \\ \therefore x=-1 \quad \text{Or} \quad x &= 2 \end{aligned}$$

Since the values of x satisfy the given equation, thus $x = -1$ and $x = 2$ will be the roots of $(x+1)(x-2) = 0$.

Try These

Solve the following equations-

$$\begin{array}{lll} \text{(i)} \quad x^2 - 11x = 0 & \text{(ii)} \quad (x-1)^2 = 0 & \text{(iii)} \quad (x+3)^2 = 0 \\ \text{(iv)} \quad (x-2)(x+3) = 0 & \text{(v)} \quad x(x-1) = 0 & \end{array}$$

Solving Quadratic Equations by Factorization Method

At the beginning of this chapter, different situations were described and we formed equations (i), (ii) and (iii) on their basis. We will now solve them.

Equation (i) : On comparing $x^2 - 20^2 = 0$ with the identify $a^2 - b^2 = (a-b)(a+b)$.

$$\begin{aligned} x^2 - 20^2 &= (x-20)(x+20) \\ \therefore (x-20)(x+20) &= 0 \\ \Rightarrow (x-20) = 0 \quad \text{Or} \quad (x+20) &= 0 \\ \Rightarrow x-20 = 0 \quad \text{Or} \quad x+20 &= 0 \\ \Rightarrow x = 20 \quad \text{Or} \quad x = -20 \end{aligned}$$

Because length and breadth can't be negative therefore x can't be -20 . In this context x has been taken as breadth of the rectangular garden.

$$\begin{aligned} \therefore \text{Breath of rectangular garden is} &= 20 \text{ meter.} \\ \text{and length will be } 2x &= 2 \times 20 = 40 \text{ meter} \end{aligned}$$

Equation (ii) : For the given flower bed, we have to find perpendicular height and length of base in $x^2 + 30x - 1000 = 0$.

Because, left hand side of equation (ii) is a quadratic polynomial, so we will factorize it.

$$\begin{aligned} x^2 + 50x - 20x - 1000 &= 0 && (\because 50x - 20x = 30x) \\ \Rightarrow x(x + 50) - 20(x + 50) &= 0 \\ \Rightarrow (x + 50)(x - 20) &= 0 \\ \Rightarrow (x + 50) = 0 \quad \text{Or} \quad (x - 20) &= 0 \\ \Rightarrow x + 50 = 0 \quad \text{Or} \quad x - 20 = 0 \\ \Rightarrow x = -50 \quad \text{Or} \quad x = 20 \end{aligned}$$

Thus, perpendicular height of right-angle flower bed = 20 meters and length of its base should be $x + 30 = 20 + 30 = 50$ meters.

Similarly, we can get the values by finding factors of equation (iii)

In examples given below we will get solutions by factorization method.

Example-3. Solve the following equations by factorization-

$$\begin{aligned} \text{(i)} \quad 8x^2 - 22x - 21 &= 0 && \text{(ii)} \quad x^2 + 2\sqrt{2}x - 6 = 0 \\ \text{(iii)} \quad \sqrt{3}x^2 + 10x + 7\sqrt{3} &= 0 && \text{(iv)} \quad \frac{x+3}{x-2} - \frac{1-x}{x} = \frac{17}{4}, x \neq 0 \end{aligned}$$

Solution (i) :

$$\begin{aligned} 8x^2 - 22x - 21 &= 0 \\ \Rightarrow 8x^2 - 28x + 6x - 21 &= 0 \\ \Rightarrow 4x(2x - 7) + 3(2x - 7) &= 0 \\ \Rightarrow (2x - 7)(4x + 3) &= 0 \\ \Rightarrow (2x - 7) = 0 \quad \text{Or} \quad (4x + 3) &= 0 \\ \Rightarrow 2x - 7 = 0 \quad \text{Or} \quad 4x + 3 = 0 \\ \Rightarrow 2x = 7 \quad \text{Or} \quad 4x = -3 \\ \Rightarrow x = \frac{7}{2} \quad \text{Or} \quad x = -\frac{3}{4} \end{aligned}$$

Thus $x = \frac{7}{2}, -\frac{3}{4}$ are two roots of the given equation.

Solution (ii) :

$$\begin{aligned} x^2 + 2\sqrt{2}x - 6 &= 0 \\ \Rightarrow x^2 + 3\sqrt{2}x - \sqrt{2}x - 6 &= 0 \\ \Rightarrow x(x + 3\sqrt{2}) - \sqrt{2}(x + 3\sqrt{2}) &= 0 \\ \Rightarrow (x + 3\sqrt{2})(x - \sqrt{2}) &= 0 \end{aligned}$$

$$\Rightarrow (x + 3\sqrt{2}) = 0 \quad \text{Or} \quad (x - \sqrt{2}) = 0$$

$$\Rightarrow x + 3\sqrt{2} = 0 \quad \text{Or} \quad x - \sqrt{2} = 0$$

$$\Rightarrow x = -3\sqrt{2} \quad \text{Or} \quad x = \sqrt{2}$$

Thus, $x = -3\sqrt{2}, \sqrt{2}$ are two roots of the given equation.

Solution (iii): $\sqrt{3}x^2 + 10x + 7\sqrt{3} = 0$

$$\Rightarrow \sqrt{3}x^2 + 3x + 7x + 7\sqrt{3} = 0$$

$$\Rightarrow \sqrt{3}x(x + \sqrt{3}) + 7(x + \sqrt{3}) = 0$$

$$\Rightarrow (x + \sqrt{3})(\sqrt{3}x + 7) = 0$$

$$\Rightarrow (x + \sqrt{3}) = 0 \quad \text{Or} \quad (\sqrt{3}x + 7) = 0$$

$$\Rightarrow x + \sqrt{3} = 0 \quad \text{Or} \quad \sqrt{3}x + 7 = 0$$

$$\Rightarrow x = -\sqrt{3} \quad \text{Or} \quad x = -\frac{7}{\sqrt{3}}$$

Thus, $x = -\sqrt{3}, -\frac{7}{\sqrt{3}}$ are two roots of the given equation.

Solution (iv): $\frac{x+3}{x-2} - \frac{1-x}{x} = \frac{17}{4}$, $x \neq 0$

$$\Rightarrow \frac{x(x+3) - (1-x)(x-2)}{x(x-2)} = \frac{17}{4}$$

$$\Rightarrow \frac{x^2 + 3x - (x - x^2 - 2 + 2x)}{x^2 - 2x} = \frac{17}{4}$$

$$\Rightarrow \frac{x^2 + 3x - x + x^2 + 2 - 2x}{x^2 - 2x} = \frac{17}{4}$$

$$\Rightarrow \frac{2x^2 + 2}{x^2 - 2x} = \frac{17}{4}$$

$$\Rightarrow 4(2x^2 + 2) = 17(x^2 - 2x)$$

$$\Rightarrow 8x^2 + 8 = 17x^2 - 34x$$

$$\Rightarrow 17x^2 - 8x^2 - 34x - 8 = 0$$

$$\Rightarrow 9x^2 - 34x - 8 = 0$$

$$\Rightarrow 9x^2 - 36x + 2x - 8 = 0$$

$$\begin{aligned} \Rightarrow 9x(x-4) + 2(x-4) &= 0 \\ \Rightarrow (x-4)(9x+2) &= 0 \\ \Rightarrow (x-4) = 0 \quad \text{Or} \quad (9x+2) &= 0 \\ \Rightarrow x-4 = 0 \quad \text{Or} \quad 9x+2 &= 0 \\ \Rightarrow x = 4 \quad \text{Or} \quad x = \frac{-2}{9} \end{aligned}$$

Thus, $x = 4, \frac{-2}{9}$ are two roots of the given equation.

Exercise - 2

1. Verify whether values are roots of equation or not-

(i) $2x^2 + x - 6 = 0;$ $x = 2, x = -\frac{3}{2}$

(ii) $x^2 - 4x + 4 = 0;$ $x = 2, x = -3$

(iii) $6x^2 - 6x - 12 = 0;$ $x = -3, x = 4$

(iv) $4x^2 - 9x = 0;$ $x = 0, x = \frac{9}{4}$

(v) $x^2 - 3\sqrt{3}x + 6 = 0;$ $x = \sqrt{3}, x = -2\sqrt{3}$

2. Find the roots of the given quadratic equation-

(i) $(x-4)(x-2) = 0$ (ii) $(2x+3)(3x-7) = 0$

(iii) $(x-7)^2 = 0$ (iv) $x^2 - 11x = 0$

(v) $(x+12)^2 = 0$ (vi) $x(x+1) = 0$

3. Is $\sqrt{2}$ a root of equation $x^2 + 2x - 4 = 0$?

4. Find the roots of the following square equations by factorization:-

(i) $9x^2 - 3x - 2 = 0$ (ii) $4x^2 + 5x = 0$

(iii) $3x^2 - 11x + 10 = 0$ (iv) $5x^2 + 3x - 2 = 0$

(v) $6x^2 + 7x + 2 = 0$ (vi) $4\sqrt{3}x^2 + 5x - 2\sqrt{3} = 0$

(vii) $10x - \frac{1}{x} = 3$ (viii) $x^2 - 4\sqrt{2}x + 6 = 0$

(ix) $abx^2 + (b^2 - ac)x - bc = 0$

(x) $\frac{x+1}{x-1} - \frac{x-1}{x+1} = \frac{5}{6};$ $x \neq 1, -1$

Applications of quadratic equations

We often encounter many situations in our daily life which we solve by forming quadratic equations around them. We will now look at some examples from day to day where we can form quadratic equations and find their solutions.

Example-4. If the sum of a number and its reciprocal is $2\frac{1}{30}$ then find the number.

Solution: Let the number be x and then its reciprocal will be $\frac{1}{x}$.

$$\begin{aligned} \therefore x + \frac{1}{x} &= 2\frac{1}{30} \\ \Rightarrow \frac{x^2 + 1}{x} &= \frac{61}{30} \\ \Rightarrow 30(x^2 + 1) &= 61x \\ \Rightarrow 30x^2 - 61x + 30 &= 0 \\ \Rightarrow 30x^2 - 36x - 25x + 30 &= 0 \\ \Rightarrow 6x(5x - 6) - 5(5x - 6) &= 0 \\ \Rightarrow (5x - 6)(6x - 5) &= 0 \\ \Rightarrow 5x - 6 = 0 \quad \text{Or} \quad 6x - 5 = 0 \\ \Rightarrow x = \frac{6}{5} \quad \text{Or} \quad x = \frac{5}{6} \end{aligned}$$

Therefore, the numbers are $x = \frac{6}{5}$ and $x = \frac{5}{6}$.

Example-5. A chessboard contains 64 equal squares and the area of each square is 6.25 cm^2 . A 2 cm wide border surrounds the board on all sides. Find the length of one side of the chess board.

Solution : Let the length of chessboard with border be $x \text{ cm}$.

Border is 2 cm wide

Addition to length of board due to border $= 2 + 2 = 4 \text{ cm}$

Area of chessboard without border $= (x - 4)^2$

Chessboard contains 64 equal squares,

and area of each square is 6.25 cm^2

$$\begin{aligned} \therefore (x - 4)^2 &= 64 \times 6.25 \\ \Rightarrow x^2 - 8x + 16 &= 400 \\ \Rightarrow x^2 - 8x + 16 - 400 &= 0 \end{aligned}$$

$$\begin{aligned} \Rightarrow x^2 - 8x - 384 &= 0 \\ \Rightarrow x^2 - 24x + 16x - 384 &= 0 \\ \Rightarrow x(x - 24) + 16(x - 24) &= 0 \\ \Rightarrow (x - 24)(x + 16) &= 0 \\ \Rightarrow x - 24 = 0 \quad \text{Or} \quad x + 16 = 0 \\ \Rightarrow x = 24 \quad \text{Or} \quad x = -16 \end{aligned}$$

The length of side of chessboard cannot be negative.

Thus, the length of one side of chessboard will be 24 cm

Example-6. The sum of marks obtained by Mohan in mathematics and science in a class test is 28. If his marks in mathematic are increased by 3 and marks in science decreased by 4, then the product of marks obtained in both subjects is 180. Find the marks obtained by Mohan in mathematics and science.

Solution: If Mohan got x marks in mathematics, then his marks in science will be $= 28 - x$

When Mohan gets 3 more marks in mathematics,

then his marks in mathematics $= x + 3$

And when his marks in science are reduced by 4, then his marks in science $= 28 - x - 4$

\therefore Product of his marks in mathematics and science $= 180$ (given)

$$\therefore (x + 3)(28 - x - 4) = 180$$

$$\Rightarrow (x + 3)(24 - x) = 180$$

$$\Rightarrow -x^2 - 3x + 24x + 72 = 180$$

$$\Rightarrow -x^2 + 21x + 72 - 180 = 0$$

$$\Rightarrow -x^2 + 21x - 108 = 0$$

$$\Rightarrow x^2 - 12x - 9x + 108 = 0$$

$$\Rightarrow x(x - 12) - 9(x - 12) = 0$$

$$\Rightarrow (x - 12)(x - 9) = 0$$

$$\Rightarrow x - 12 = 0 \quad \text{Or} \quad x - 9 = 0$$

$$\Rightarrow x = 12 \quad \text{Or} \quad x = 9$$

$$\text{When } x = 12 \Rightarrow 28 - x = 28 - 12 = 16$$

$$\text{When } x = 9 \Rightarrow 28 - x = 28 - 9 = 19$$

Thus, if Mohan got 12 marks in mathematics, then he got 16 marks in science else if he got 9 marks in mathematics, then he got 19 marks in science.

Example-7. Present age of a man is equal to the square of present age of his son. If 1 year ago man's age was 8 times that of his son's age then find the present age of both.

Solution : Let the present age of son = x years.

Then, present age of man = x^2 year

Age of son one year ago = $x - 1$ years

and age of man one year ago = $x^2 - 1$ years

\therefore 1 year ago age of man was 8 times that of his son

$$\therefore x^2 - 1 = 8(x - 1)$$

$$\Rightarrow x^2 - 1 = 8x - 8$$

$$\Rightarrow x^2 - 8x + 7 = 0$$

$$\Rightarrow x^2 - 7x - x + 7 = 0$$

$$\Rightarrow x(x - 7) - 1(x - 7) = 0$$

$$\Rightarrow (x - 7)(x - 1) = 0$$

$$\Rightarrow x - 7 = 0 \quad \text{Or} \quad x - 1 = 0$$

$$\Rightarrow x = 7 \quad \text{Or} \quad x = 1$$

For $x = 1$, age of son and man both would be 1 year, which is not possible.

So, on taking $x = 7$ years

Present age of son $x = 7$ years

Present age of man $x^2 = (7)^2 = 49$ years

Example-8. Perimeter of a rectangular field is 82 meter and its area is 400 square meter. Find the breadth of the field.

Solution : Let the breadth of rectangular field be x meter

Perimeter of rectangular field = 82 meter

$$\Rightarrow 2(\text{length} + \text{breadth}) = 82 \text{ meter}$$

$$\Rightarrow (\text{length} + \text{breadth}) = 41 \text{ meter}$$

$$\Rightarrow (\text{length} + x) = 41 \text{ meter}$$

$$\Rightarrow \text{length} = 41 - x \text{ meter}$$

\therefore Area of rectangular field = 400 square meter

$$\Rightarrow \text{length} \times \text{breadth} = 400 \text{ square meter}$$

$$\Rightarrow (41 - x)x = 400$$

$$\begin{aligned}
&\Rightarrow 41x - x^2 = 400 \\
&\Rightarrow -x^2 + 41x - 400 = 0 \\
&\Rightarrow x^2 - 41x + 400 = 0 \\
&\Rightarrow x^2 - 25x - 16x + 400 = 0 \\
&\Rightarrow x(x - 25) - 16(x - 25) = 0 \\
&\Rightarrow (x - 25)(x - 16) = 0 \\
&\Rightarrow x - 25 = 0 \quad \text{Or} \quad x - 16 = 0 \\
&\Rightarrow x = 25 \quad \text{Or} \quad x = 16
\end{aligned}$$

Thus, breadth of rectangular field will be 16 meter and length will be 25 meter. Of the two values of x , one will represent breadth and the other length.

Example-9. Some students planned a picnic. The budget for food was Rs. 500. But five of these failed to go and thus the cost of food for each member increased by Rs. 5. How many students attended the picnic?

Solution : Let the number of students who planned for picnic be x

$$\therefore \text{Total amount given by } x \text{ students for food expenditure} = \text{Rs. } 500$$

$$\therefore \text{Amount given by one student for food expenditure} = \text{Rs. } \frac{500}{x}$$

But five students failed to go
then, number of students going = $x - 5$

$$\text{Amount given by } x - 5 \text{ students for food expenditure} = \text{Rs. } 500$$

$$\text{Amount given by one student for food expenditure} = \text{Rs. } \frac{500}{x - 5}$$

According to question, 5 students failed to go and due to this the cost of food for each member increased by Rs. 5

$$\begin{aligned}
\therefore \frac{500}{x - 5} - \frac{500}{x} &= 5 \\
\Rightarrow \frac{500x - 500(x - 5)}{x(x - 5)} &= 5 \\
\Rightarrow \frac{500\{x - (x - 5)\}}{x(x - 5)} &= 5
\end{aligned}$$

$$\begin{aligned}
\Rightarrow \frac{500(x-x+5)}{x(x-5)} &= 5 \\
\Rightarrow \frac{500 \times 5}{5} &= x^2 - 5x \\
\Rightarrow x^2 - 5x - 500 &= 0 \\
\Rightarrow x^2 - 25x + 20x - 500 &= 0 \\
\Rightarrow x(x-25) + 20(x-25) &= 0 \\
\Rightarrow (x-25)(x+20) &= 0 \\
\Rightarrow x-25=0 \quad \text{Or} \quad x+20=0 \\
\Rightarrow x=25 \quad \text{Or} \quad x=-20 \\
\therefore \text{Number of students can't be negative, thus } x &= 25 \\
\therefore \text{Number of students who attended the picnic } &= x-5=20.
\end{aligned}$$

Example-10. A person buys a number of books for Rs. 80. If he had bought 4 more books for the same amount, each book would have cost Rs. 1 less. How many books did he buy?

Solution : Let the number of books bought be x .

$$\therefore \text{Cost of } x \text{ books} = \text{Rs. } 80$$

$$\therefore \text{Cost of one book} = \text{Rs. } \frac{80}{x}$$

If he had bought 4 more books then number of books $= x + 4$

$$\therefore \text{Cost of } x + 4 \text{ books} = \text{Rs. } 80$$

$$\therefore \text{Cost of 1 book} = \text{Rs. } \frac{80}{x+4}$$

According to questions Rs. $\frac{80}{x+4}$ is Rs. 1 less than Rs. $\frac{80}{x}$ –

$$\therefore \frac{80}{x} - 1 = \frac{80}{x+4}$$

$$\Rightarrow \frac{80}{x} - \frac{80}{x+4} = 1$$

$$\Rightarrow 80 \left[\frac{1}{x} - \frac{1}{x+4} \right] = 1$$

$$\Rightarrow 80 \left[\frac{x+4-x}{x(x+4)} \right] = 1$$

$$\begin{aligned} \Rightarrow \frac{80 \times 4}{(x^2 + 4x)} &= 1 \\ \Rightarrow 320 &= x^2 + 4x \\ \Rightarrow x^2 + 4x - 320 &= 0 \\ \Rightarrow x^2 + 20x - 16x - 320 &= 0 \\ \Rightarrow x(x + 20) - 16(x + 20) &= 0 \\ \Rightarrow (x + 20)(x - 16) &= 0 \\ \Rightarrow (x + 20) = 0 \text{ Or } (x - 16) &= 0 \\ \Rightarrow x = -20 \text{ (Unacceptable) or } x = 16 \end{aligned}$$

Thus, number of books = 16.

Solution of a quadratic equation by completing the square

In the previous section, we learnt factorization method of obtaining the roots of a quadratic equation. In this section, we shall study another method. In this method we convert the equation into $(x - a)^2$ or $(x + a)^2$ form. To do this we need to add certain terms to both sides of the equation.

This method is used in the following example-

Example-11. Solve the square equation $x^2 + 6x = 0$ by the method of completing the square.

Solution : $x^2 + 6x = 0$

$$\Rightarrow x^2 + 2x \times 3 = 0$$

To make the equation perfect square we need to add square of coefficient of $2x$, which is square of 3 or 9 to both sides of the equation.

$$\Rightarrow x^2 + 2x \times 3 + 3^2 = 3^2$$

$$\Rightarrow x^2 + 2 \times x \times 3 + 3^2 = 9$$

$$\Rightarrow (x + 3)^2 = 9 \quad (\text{By using the identity } x^2 + 2xa + a^2 = (x + a)^2)$$

$$\Rightarrow x + 3 = \pm\sqrt{9}$$

$$\Rightarrow x + 3 = \pm 3$$

On taking (+) sign	On taking (-) sign
$\Rightarrow x + 3 = +3$	$x + 3 = -3$
$\Rightarrow x = 3 - 3$	$x = -3 - 3$
$\Rightarrow x = 0$	$x = -6$

Because x is common in $x^2 + 6x$, therefore we can write the equations as $x(x + 6) = 0$. Now, it is clear that $x = 0$ or $x = -6$. We can see that the solution of problem is not affected by the method used.

Example-12. Solve the quadratic equation $x^2 - 6x + 5 = 0$ by the method of completing the squares.

Solution : $x^2 - 6x + 5 = 0$

$$\Rightarrow x^2 - 2x \times 3 + 5 = 0$$

$$\Rightarrow x^2 - 2x \times 3 = -5$$

By adding square of coefficient of $2x$, that is square of 3 to both sides of equation.

$$\Rightarrow x^2 - 2x \times 3 + 3^2 = -5 + 3^2$$

$$\Rightarrow (x - 3)^2 = -5 + 9 \quad \left[\because x^2 - 2xa + a^2 = (x - a)^2 \right]$$

$$\Rightarrow (x - 3)^2 = 4$$

$$\Rightarrow x - 3 = \pm\sqrt{4}$$

$$\Rightarrow x - 3 = \pm 2$$

On taking (+) sign	On taking (-) sign
$\Rightarrow x - 3 = +2$	$x - 3 = -2$
$\Rightarrow x = 2 + 3$	$x = -2 + 3$
$\Rightarrow x = 5$	$x = 1$

On splitting the middle term of polynomial, we find that $(x - 5)(x - 1) = 0$ is the equation and thus the roots are $x = 5$ and $x = 1$. But here there is no common term.

Example-13. Solve the quadratic equation $x^2 - \frac{5}{2}x - 3 = 0$.

Solution : $x^2 - \frac{5}{2}x - 3 = 0$

$$\Rightarrow$$

$$x^2 - \frac{5}{2}x = 3$$

$$\Rightarrow x^2 - 2x \times \frac{1}{2} \times \frac{5}{2} = 3$$

$$\Rightarrow x^2 - 2x \times \frac{5}{4} = 3$$

By adding square of $\frac{5}{4}$ which is coefficient of $2x$ to both sides of the equation,

$$\Rightarrow x^2 - 2x \times \frac{5}{4} + \left(\frac{5}{4}\right)^2 = 3 + \left(\frac{5}{4}\right)^2$$

$$\Rightarrow \left(x - \frac{5}{4}\right)^2 = \frac{25}{16} + 3$$

$$\Rightarrow \left(x - \frac{5}{4}\right)^2 = \frac{25 + 48}{16}$$

$$\Rightarrow \left(x - \frac{5}{4}\right)^2 = \frac{73}{16}$$

$$\Rightarrow x - \frac{5}{4} = \pm \sqrt{\frac{73}{16}}$$

$$\Rightarrow x = \frac{5}{4} \pm \sqrt{\frac{73}{16}}$$

On taking (+) sign	On taking (-) sign
$\Rightarrow x = \frac{5}{4} + \sqrt{\frac{73}{16}}$	$x = \frac{5}{4} - \sqrt{\frac{73}{16}}$
$\Rightarrow x = \frac{5}{4} + \frac{\sqrt{73}}{4}$	$x = \frac{5}{4} - \frac{\sqrt{73}}{4}$
$\Rightarrow x = \frac{5 + \sqrt{73}}{4}$	$x = \frac{5 - \sqrt{73}}{4}$

Can we find the solution of the polynomial by taking common terms or splitting the middle term?

Example-14. Solve the quadratic equation $2x^2 - 7x + 3 = 0$ dks gy dhft,A

Solution : $2x^2 - 7x + 3 = 0$

$$\Rightarrow 2x^2 - 7x = -3$$

On dividing both sides of equation by 2

$$\Rightarrow x^2 - \frac{7}{2}x = -\frac{3}{2}$$

$$\begin{aligned}
\Rightarrow x^2 - 2x \times \frac{1}{2} \times \frac{7}{2} &= -\frac{3}{2} && \left[\because \frac{7}{2} = 2 \times \frac{1}{2} \times \frac{7}{2} = 2 \times \frac{7}{4} \right] \\
\Rightarrow x^2 - 2x \times \frac{7}{4} + \left(\frac{7}{4}\right)^2 &= -\frac{3}{2} + \left(\frac{7}{4}\right)^2 && \text{(Adding the square of } \frac{7}{4} \text{ which} \\
&&& \text{is the coefficient of } 2x \text{ to both sides)} \\
\Rightarrow \left(x - \frac{7}{4}\right)^2 &= -\frac{3}{2} + \frac{49}{16} && \left[\because x^2 - 2xa + a^2 = (x-a)^2 \right] \\
\Rightarrow \left(x - \frac{7}{4}\right)^2 &= \frac{-24 + 49}{16} \\
\Rightarrow \left(x - \frac{7}{4}\right)^2 &= \frac{25}{16} \\
\Rightarrow x - \frac{7}{4} &= \pm \sqrt{\frac{25}{16}} \\
\Rightarrow x - \frac{7}{4} &= \pm \frac{5}{4}
\end{aligned}$$

Taking (+) sign	Taking (-) sign
$\Rightarrow x - \frac{7}{4} = +\frac{5}{4}$	$x - \frac{7}{4} = -\frac{5}{4}$
$\Rightarrow x = \frac{5}{4} + \frac{7}{4}$	$x = -\frac{5}{4} + \frac{7}{4}$
$\Rightarrow x = \frac{12}{4}$	$x = \frac{2}{4}$
$\Rightarrow x = 3$	$x = \frac{1}{2}$

Can we solve this sum by splitting the middle term? Try.

Try These

Solve the following quadratic equations by the method of completing the square.

(i) $x^2 - \frac{3}{4}x + 3 = 0$

(ii) $2x^2 + 5x + 3 = 0$

(iii) $9x^2 - 15x + 6 = 0$

Example-15. Solve $\sqrt{6+\sqrt{6+\sqrt{6+\dots}}}$.

Solution : Let $x = \sqrt{6+\sqrt{6+\sqrt{6+\dots}}}$

$$\Rightarrow x = \sqrt{6+x} \quad (\text{On squaring both sides})$$

$$\Rightarrow x^2 = (\sqrt{6+x})^2$$

$$\Rightarrow x^2 = 6+x$$

$$\Rightarrow x^2 - x - 6 = 0$$

$$\Rightarrow x^2 - 3x + 2x - 6 = 0$$

$$\Rightarrow x(x-3) + 2(x-3) = 0$$

$$\Rightarrow (x-3)(x+2) = 0$$

$$\Rightarrow (x-3) = 0 \quad \text{Or} \quad (x+2) = 0$$

$$\Rightarrow x = 3 \quad \text{Or} \quad x = -2$$

Thus $x = 3, -2$

Exercise - 3

1. Solve the following quadratic equations by completing the squares method.

(i) $2x^2 + x - 4 = 0$

(ii) $3x^2 + 11x + 10 = 0$

(iii) $5x^2 - 6x - 2 = 0$

(iv) $x^2 - 4\sqrt{2}x + 6 = 0$

(v) $3x^2 + 2x - 1 = 0$

(vi) $x^2 - 4x + 3 = 0$

2. Find the solution of $\sqrt{7+\sqrt{7+\sqrt{7+\sqrt{7+\dots}}}}$.

3. Find two consecutive positive natural numbers, sum of whose squares is 365.

4. The product of two consecutive natural numbers is 20. Find the numbers.

5. Find two numbers whose sum is 48 and product is 432.

6. Area of a right angle triangle is 165 square meter. If the height of the right triangle is 7 cm more than its base, then find the height of the triangle.

7. Perimeter and area of a flower bed are 76 meter and 357 square meters respectively. Find the length and breadth of the flower bed.

8. Area of a rectangular park is 100 square meter. Length of the park is 15 meter more than the breadth. If someone wants to fence along the sides of the park and cost of fencing one meter is Rs. 5, then find the total cost of fencing all sides of the park.

9. The sum of present ages of a man and his son is 45 years. 5 years ago product of their ages was 4 times that of age of man. Find their present ages.
10. The product of Neelmani's age 5 years ago and 8 years ago is 40. Find Neelmani's present age.
11. Some students planned a picnic. The budget for food was Rs. 480. But 8 of them failed to go and thus the cost of food for each member increased by Rs. 10. How many attended the picnic?
12. The sum of marks obtained by Kamal in English and mathematics is 40 in class test of grade 10. If the marks which he got in mathematics are increased by 3 and marks which he got in English decreased by 4 then the product of marks is 360. Find the marks obtained by him in mathematics and English.

INDIAN MATHEMATICIAN - SRIDHARACHARYA

Sridharacharya was the first Indian mathematician to solve quadratic (square) equations involving one variable. He had worked in the field of Arithmetic, Geometry, Square roots, Cube roots etc. Sridharacharya was a famous mathematician between the era of Brahmagupta (628 AD) and Bhaskaracharya (1150 AD).

It is said that from the Himalayas in the north to the Malwas in the south and from the west to the east sea coasts, there was no mathematician who was better than Sridharacharya.

चतुराहत वर्ग समै रूपैः पक्ष द्वयं गुणयेत् ।
अव्यक्त वर्ग रूपैर्युक्तौ पक्षौततो मूलम् ।।

From the book, "Paati Ganit Avam Ganit Ke Itihas"
Authors : Venugopal and Dr. Herrer

Formula to Solve Quadratic Equations

Standard form of quadratic (square) is $ax^2 + bx + c = 0$, where a, b, c are real numbers and $a \neq 0$

On dividing both sides by the coefficient of x^2 -

$$x^2 + \frac{b}{a}x + \frac{c}{a} = 0$$

$$\Rightarrow x^2 + \frac{b}{a}x = -\frac{c}{a}$$

$$\Rightarrow x^2 + 2 \cdot \frac{b}{2a} x = -\frac{c}{a} \text{ (On squaring the coefficient } 2x \text{ and adding to both sides)}$$

$$\Rightarrow x^2 + 2 \cdot \frac{b}{2a} x + \left(\frac{b}{2a}\right)^2 = -\frac{c}{a} + \left(\frac{b}{2a}\right)^2$$

$$\Rightarrow \left(x + \frac{b}{2a}\right)^2 = \frac{-c}{a} + \frac{b^2}{4a^2}$$

$$\Rightarrow \left(x + \frac{b}{2a}\right)^2 = \frac{-4ac + b^2}{4a^2}$$

$$\Rightarrow \left(x + \frac{b}{2a}\right)^2 = \frac{(b^2 - 4ac)}{4a^2}$$

$$\Rightarrow x + \frac{b}{2a} = \pm \sqrt{\frac{b^2 - 4ac}{4a^2}} \quad \text{(Taking square root)}$$

$$\Rightarrow x + \frac{b}{2a} = \frac{\pm \sqrt{b^2 - 4ac}}{2a}$$

$$\Rightarrow x = -\frac{b}{2a} \pm \frac{\sqrt{b^2 - 4ac}}{2a}$$

$$\Rightarrow x = \frac{-b \pm \sqrt{b^2 - 4ac}}{2a}$$

Think and Discuss

Mention the method by which $3x^2 + 7x + 1 = 0$ can be solved? Will the solution be same for all methods? Why are completing the square and splitting the middle term methods not so easy?

Let us solve some quadratic equations.

Example-16. Solve the quadratic equation $(x-1)(2x-1) = -2$.

Solution : $(x-1)(2x-1) = -2$

$$\Rightarrow 2x^2 - 2x - x + 1 = 0$$

$$\Rightarrow 2x^2 - 3x + 1 = 0$$

On comparing the equation with the standard form $ax^2 + bx + c = 0$

$$a = 2, b = -3, c = 1$$

On putting the values of a, b and c in the formula $x = \frac{-b \pm \sqrt{b^2 - 4ac}}{2a}$

$$x = \frac{-(-3) \pm \sqrt{(-3)^2 - 4 \times 2 \times 1}}{2(2)}$$

$$x = \frac{3 \pm \sqrt{9-8}}{4}$$

$$x = \frac{3 \pm 1}{4}$$

On taking (+) sign	On taking (-) sign
$x = \frac{3+1}{4} = \frac{4}{4}$ $x = 1$	$x = \frac{3-1}{4} = \frac{2}{4}$ $x = \frac{1}{2}$

Thus, the roots of the equation are $x = 1, \frac{1}{2}$.

Try These

Solve the following equations:-

(i) $3x^2 - 2x + 2 = 0$ (ii) $x^2 - 2x + 1 = 0$

Discriminant of Quadratic Equation

In the quadratic equation $ax^2 + bx + c = 0$, $x = \frac{-b \pm \sqrt{b^2 - 4ac}}{2a}$. In the formula

$b^2 - 4ac$ is said to be discriminant of the quadratic equation. It can also written as $D = b^2 - 4ac$. It is called discriminant because it discriminates between the two values of the quadratic equation. If it is zero then the both values are equal.

Let us try to find the discriminant of some quadratic equations:-

Example-17. Find the discriminant of the quadratic equation $4x^2 - 4x + 1 = 0$.

Solution : On comparing $4x^2 - 4x + 1 = 0$ with the standard form, $ax^2 + bx + c = 0$ of quadratic equation we find that:

Here $a = 4, b = -4, c = 1$

Discriminant $D = b^2 - 4ac$

$$D = (-4)^2 - 4 \times 4 \times 1$$

$$D = 16 - 16$$

$$D = 0$$

Example-18. Find the discriminant of the quadratic equation $2x^2 + 5x + 5 = 0$.

Solution : On comparing $2x^2 + 5x + 5 = 0$ with the standard form, $ax^2 + bx + c = 0$ of quadratic equation we find that:

Here $a = 2, b = 5, c = 5$

$\therefore D = b^2 - 4ac$

$$D = 5^2 - 4 \times 2 \times 5$$

$$D = 25 - 40$$

$$D = -15$$

Example-19. Find the discriminant of the quadratic equation $3x^2 - 2\sqrt{8}x + 2 = 0$.

Solution : On comparing $3x^2 - 2\sqrt{8}x + 2 = 0$ with the standard form, $ax^2 + bx + c = 0$ of quadratic equation we find that:

$$a = 3, b = -2\sqrt{8}, c = 2$$

$\therefore D = b^2 - 4ac$

$$D = (-2\sqrt{8})^2 - 4 \times 3 \times 2$$

$$D = 4 \times 8 - 24$$

$$D = 32 - 24$$

$$D = 8$$

Try These

Find the discriminant of the following quadratic equations:

(i) $2x^2 - 2\sqrt{2}x + 1 = 0$ (ii) $16x^2 + 24x + 9 = 0$

(iii) $9x^2 - 10x + 15 = 0$ (iv) $x^2 + 16x + 64 = 0$

Nature of Roots of Quadratic Equation

In the above examples we found the discriminant of various quadratic equations by using the formula $D = b^2 - 4ac$. In the examples the values of D were respectively 0, -15, 8. These values of D were zero, negative or positive numbers. This means that discriminant can be zero, negative or positive. Does this give us some important information about the roots of quadratic equations? Let us try to find out.

∴ The formula to find the roots $ax^2 + bx + c = 0$ where a, b, c are real numbers and $a \neq 0$ is given by:

$$x = \frac{-b \pm \sqrt{b^2 - 4ac}}{2a}$$

$$\text{where } b^2 - 4ac = D$$

thus,

$$x = \frac{-b \pm \sqrt{D}}{2a}$$

Let us discuss the following three cases.

Case-1. If $D = 0$ then

$$x = \frac{-b \pm \sqrt{0}}{2a}$$

$$x = \frac{-b \pm 0}{2a}$$

$D = b^2 - 4ac$ discriminates (differentiates) between the nature of roots. So it is called discriminant.

On taking (+) value	On taking (-) value
$x = \frac{-b+0}{2a} = \frac{-b}{2a}$	$x = \frac{-b-0}{2a} = \frac{-b}{2a}$

Here, both values of x are equal and real.

Conclusion: If $D = 0$ then both roots of the quadratic equations are real and equal.

Case-2. If $D =$ any positive number, then

Let $D = 49$

$$x = \frac{-b \pm \sqrt{49}}{2a}$$

$$x = \frac{-b \pm 7}{2a}$$

On taking (+) sign	On taking (-) sign
$x = \frac{-b + 7}{2a}$	$x = \frac{-b - 7}{2a}$

Here, the values of x are distinct and both are real numbers.

Conclusion: If $D > 0$ i.e. positive then the roots of quadratic equation are distinct and real.

Case-3. If $D =$ any negative number, then

Say, $D = -81$

$$x = \frac{-b \pm \sqrt{-81}}{2a}$$

The roots of a negative number are imaginary.

On taking (+) sign	On taking (-) sign
$x = \frac{-b + \sqrt{-81}}{2a}$	$x = \frac{-b - \sqrt{-81}}{2a}$

Here, both the values of x are distinct but being the square root of a negative number they are imaginary.

Conclusion : If $D < 0$ i.e. negative, the roots are distinct but imaginary, i.e. there are no real roots.

Some examples of identifying the nature of roots

Let us try to see some examples of the nature of roots of quadratic equations.

Example-20. Find the nature of roots of the quadratic equation $x^2 - 4x + 4 = 0$.

Solution : On comparing $x^2 - 4x + 4 = 0$ with $ax^2 + bx + c = 0$, we find that:

$$a = 1, b = -4, c = 4$$

On putting the values in discriminant, $D = b^2 - 4ac$

$$D = (-4)^2 - 4 \times 1 \times 4$$

$$D = 16 - 16$$

$$D = 0$$

\therefore Discriminant of given equation is zero, thus both roots of this equation are real and equal.

Example-21. Find the nature of roots of the quadratic equation $x^2 - 5x + 6 = 0$.

Solution : On comparing $x^2 - 4x + 4 = 0$ with $ax^2 + bx + c = 0$, we find that:

$$a = 1, b = -5, c = 6$$

On putting the values in discriminant, $D = b^2 - 4ac$

$$D = (-5)^2 - 4 \times 1 \times 6$$

$$D = 25 - 24$$

$$D = 1$$

$$D > 0 \text{ (Positive)}$$

Since, the discriminant of the given quadratic equation is positive, so the two roots are real and distinct.

Example-22. Find the nature of roots of the quadratic equation $4x^2 - x + 1 = 0$.

Solution : On comparing $4x^2 - x + 1 = 0$ with $ax^2 + bx + c = 0$, we find that:

$$a = 4, b = -1, c = 1$$

On putting the values in discriminant, $D = b^2 - 4ac$

$$D = (-1)^2 - 4 \times 4 \times 1$$

$$D = 1 - 16$$

$$D = -15 \text{ (negative)}$$

Since, the discriminant of the given quadratic equation is negative, so the two roots are distinct but imaginary.

Try These

Find the nature of roots of the following equations:-

(i) $x^2 + x + 2 = 0$

(ii) $2x^2 + x - 1 = 0$

(iii) $2x^2 + 5x + 5 = 0$

(iv) $2y^2 - 2\sqrt{6}y + 3 = 0$

Finding unknown constant coefficients

On the basis of nature of roots of a quadratic equation we can find the value of unknown coefficient of the variable term. Let us try to understand by the following example-

Example-23. Find the value of k in the quadratic equation $9x^2 + 3kx + 4 = 0$ given that the roots of the quadratic equation are equal.

Solution : On comparing the quadratic equation $9x^2 + 3kx + 4 = 0$ with the standard form $ax^2 + bx + c = 0$, we find that $a = 9, b = 3k, c = 4$

Putting these values in $D = b^2 - 4ac$

$$D = (3k)^2 - 4 \times 9 \times 4$$

$$D = 9k^2 - 144$$

When roots are equal, then $D = 0$

$$\text{Thus, } 9k^2 - 144 = 0$$

$$9k^2 = 144$$

$$k^2 = \frac{144}{9}$$

$$k^2 = 16$$

$$k = \pm 4$$

Suppose the roots were distinct and real then what could we about the value of k ?

Try These

Find the value of k in the following quadratic equations given that the roots of the quadratic equation are real and equal

(i) $16x^2 + kx + 9 = 0$ (ii) $3x^2 - 2\sqrt{8}x + k = 0$

(iii) If roots are imaginary in both questions then what can you say about k ?

Exercise-4

1. Find the discriminant of the following equations-

(i) $x^2 - 4x + 2 = 0$ (ii) $(x-1)(2x-1) = 0$

(iii) $\sqrt{3}x^2 + 2\sqrt{2}x - 2\sqrt{3} = 0$ (iv) $x^2 - 4x + a = 0$

(v) $x^2 + px + qx = 0$

2. Find the nature of roots of the following quadratic equations.

(i) $x^2 - 4x + 4 = 0$ (ii) $2x^2 + 2x + 2 = 0$

(iii) $3x^2 - 2\sqrt{6}x + 2 = 0$ (iv) $x^2 + 2\sqrt{5}x - 1 = 0$

(v) $\frac{3}{5}x^2 - \frac{2}{3}x + 1 = 0$

3. Find the value of k if the roots of the given equations are real and equal.

$$(i) \quad 2x^2 - 10x + k = 0 \quad (ii) \quad kx^2 - 5x + k = 0$$

$$(iii) \quad 2x^2 + kx + \frac{9}{8} = 0 \quad (iv) \quad 9x^2 - kx + 16 = 0$$

$$(vi) \quad kx^2 + 4x + 1 = 0$$

4. Solve the following quadratic equations with the help of formula.

$$(i) \quad 9x^2 + 7x - 2 = 0 \quad (ii) \quad 6x^2 + x - 2 = 0$$

$$(iii) \quad 6x^2 + 7x - 10 = 0 \quad (iv) \quad 2x^2 - 9x + 7 = 0$$

$$(v) \quad x^2 - 7x - 5 = 0 \quad (vi) \quad 4 - 11x = 3x^2$$

$$(vii) \quad 9x^2 - 4 = 0 \quad (viii) \quad \sqrt{3}x^2 - 10x - 8\sqrt{3} = 0$$

$$(ix) \quad 2x^2 + x - 6 = 0 \quad (x) \quad 2x^2 - 2\sqrt{6}x + 3 = 0$$

Relation between roots and coefficients of quadratic equations

We saw the relation between zeroes and coefficients of quadratic polynomials, the same relation can also be seen between the roots and coefficients of quadratic equations.

Let the roots of equation $ax^2 + bx + c = 0$ be α and β where a, b, c are real numbers and $a \neq 0$ then $(x - \alpha)(x - \beta) = 0$ or $x^2 - (\alpha + \beta)x + \alpha\beta = 0$ quadratic equations.....(1)

Quadratic equation $ax^2 + bx + c = 0$ can also be written in the following form

$$x^2 + \frac{b}{a}x + \frac{c}{a} = 0 \quad \dots\dots(2)$$

We find that equations (1) and (2) are two different forms of the same equation and thus, on comparing the two we get,

$$\text{Sum of roots } \alpha + \beta = \frac{-b}{a}$$

$$\text{and product of roots } \alpha\beta = \frac{c}{a}$$

Example-24. Find the sum and product of roots of $x^2 - 5x - 24 = 0$

Solution : On comparing equation $x^2 - 5x - 24 = 0$ with $ax^2 + bx + c = 0$, we find that

$$a = 1, b = -5, c = -24$$

$$\therefore \text{Sum of roots} = \frac{-b}{a}$$

$$\begin{aligned}
 \therefore \quad \text{Sum of roots} &= \frac{-(-5)}{1} \\
 &= \frac{5}{1} \\
 &= 5 \\
 \therefore \quad \text{Product of roots} &= \frac{c}{a} \\
 \therefore \quad \text{Product of roots} &= \frac{-24}{1} \\
 &= -24
 \end{aligned}$$

Example-25. Find the sum and product of roots of $3x^2 + 2x + 7 = 0$

Solution : On comparing equation $3x^2 + 2x + 7 = 0$ with $ax^2 + bx + c = 0$, we find that

$$a = 3, b = 2, c = 7$$

$$\begin{aligned}
 \therefore \quad \text{Sum of roots} &= \frac{-b}{a} \\
 \therefore \quad \text{Sum of roots} &= \frac{-2}{3} \\
 \therefore \quad \text{Product of roots} &= \frac{c}{a} \\
 \therefore \quad \text{Product of roots} &= \frac{7}{3}
 \end{aligned}$$

Think and Discuss

If roots are given then can we form a quadratic equation? On the basis of the concepts studied in the chapter on “polynomials” and the relations between roots and coefficient, discuss with your friends the possibility of forming a quadratic polynomial.

Forming quadratic equations if roots are known

We have learnt to find roots of quadratic equations. If roots of a quadratic equation are given then is it possible to form that quadratic equation?

Yes, we can form quadratic equations with the help of sum of roots and product of roots. Thus, if roots are given then we can form quadratic equation.

If the roots of a quadratic equation are α and β then that quadratic equation will be

$$x^2 - (\alpha + \beta)x + \alpha\beta = 0$$

So, $x^2 - (\text{Sum of roots})x + \text{Product of roots} = 0$

Example-26. Find the quadratic equation whose roots are 3 and -8 .

Solution : If the roots are given then the quadratic equation is

$$\Rightarrow x^2 - (\text{Sum of roots})x + \text{Product of roots} = 0$$

$$\Rightarrow x^2 - [3 + (-8)]x + 3 \times (-8) = 0$$

$$\Rightarrow x^2 - (-5)x + (-24) = 0$$

$$\Rightarrow x^2 + 5x - 24 = 0$$

Example-27. Find the quadratic equation whose roots are $\frac{4}{3}$ and $\frac{7}{3}$.

Solution : If the roots are given then the quadratic equation is

$$\Rightarrow x^2 - (\text{Sum of roots})x + \text{Product of roots} = 0$$

$$\Rightarrow x^2 - \left(\frac{4}{3} + \frac{7}{3}\right)x + \frac{4}{3} \times \frac{7}{3} = 0$$

$$\Rightarrow x^2 - \frac{11}{3}x + \frac{28}{9} = 0$$

$$\Rightarrow 9x^2 - 33x + 28 = 0$$

Example-28. Find the quadratic equation whose roots are $(2 + \sqrt{7})$ and $(2 - \sqrt{7})$.

Solution : If the roots are given then the quadratic equation is

$$\Rightarrow x^2 - (\text{Sum of roots})x + \text{Product of roots} = 0$$

$$\Rightarrow x^2 - [2 + \sqrt{7} + 2 - \sqrt{7}]x + (2 + \sqrt{7})(2 - \sqrt{7}) = 0$$

$$\Rightarrow x^2 - 4x + 4 - 7 = 0 \quad \because (2)^2 - (\sqrt{7})^2 = 4 - 7$$

$$\Rightarrow x^2 - 4x - 3 = 0$$

Example-29. If the sum and product of the roots of a quadratic equation are -8 and 4 respectively then find the quadratic equation.

Solution : If roots are given then the quadratic equation can be formed using

$$\Rightarrow x^2 - (\text{Sum of roots})x + \text{Product of roots} = 0$$

$$\Rightarrow x^2 - (-8)x + 4 = 0$$

$$\Rightarrow x^2 + 8x + 4 = 0$$

Try These

Form quadratic equations whose roots are

- (i) 2,3 (ii) -5,-3 (iii) $\sqrt{5}, \sqrt{3}$

Exercise-5

- Find the quadratic equations whose sum and product of roots are as following:-
 - Sum of roots = -4 Product of roots = 12
 - Sum of roots = 6 Product of roots = 9
 - Sum of roots = $2\sqrt{7}$ Product of roots = 8
 - Sum of roots = $\frac{4}{9}$ Product of roots = 1
- Find the quadratic equation whose roots are as following:
 - 7,4 (ii) -5,-11 (iii) -2,4 (iv) 12,-24
 - $\frac{4}{5}, \frac{-3}{5}$ (vi) 4,4 (vii) $\frac{-1}{3}, \frac{2}{5}$ (viii) 8,3
 - $\sqrt{3}-7, \sqrt{3}+7$ (x) $6+\sqrt{5}, 6-\sqrt{5}$
- Find the sum and product of roots of the following quadratic equations:
 - $3x^2 + 7x + 1 = 0$ (ii) $2x^2 - 2x + 3 = 0$
 - $3x^2 - 5x - 2 = 0$ (iv) $2x^2 - 2\sqrt{6}x + 3 = 0$
 - $x^2 + 6x - 6 = 0$

What We Have Learnt

- Polynomial ax^2+bx+c , is a one variable polynomial in degree 2, where a, b, c are real numbers and $a \neq 0$ gSA It is said to be a quadratic polynomial. On equating this quadratic polynomial to zero it becomes a quadratic equation $ax^2 + bx + c = 0$ Because there is only one variable in the equation and the maximum degree of the variable is 2 so it is said to be a quadratic equation in one variable.
- Quadratic equations are also known as square equations.
- The standard form of a quadratic equation in the variable x is $ax^2 + bx + c = 0$ where a, b, c are real number and $a \neq 0$.
- A quadratic equation which is in the form $ax^2 + bx + c = 0$ has only two roots.

5. We can find the roots of a quadratic equation involving one variable x by factorization and we can also find roots by putting the values of a , b , c in the quadratic formula

$$x = \frac{-b \pm \sqrt{b^2 - 4ac}}{2a}$$

6. In the formula of quadratic equations, $D = b^2 - 4ac$ is discriminant and we can know about the nature of roots if we know the value of D .
7. If α and β are two roots of a quadratic (square) equation then the quadratic equation in variable $x^2 - (\alpha + \beta)x + \alpha\beta = 0$ (here, we can take any variable such as y , z etc.)
8. If α and β are roots of a quadratic equation $ax^2 + bx + c = 0$ then the following relation holds between their roots and coefficient.

$$\text{Sum of roots } \alpha + \beta = \frac{-b}{a}$$

$$\text{Product of roots } \alpha\beta = \frac{c}{a}$$

9. When $D = b^2 - 4ac > 0$ i.e. value of D is positive then both roots of the quadratic equation are real and distinct.
10. When $D = b^2 - 4ac = 0$ i.e. value of D is 0 then the roots of the quadratic equation are real and equal.
11. When $D = b^2 - 4ac < 0$ i.e. value of D is negative then roots of the quadratic equation are imaginary and distinct

ANSWER KEY

Exercise - 1

1. (i), (iii), (v), (vi), (vii), (x) are square equations.

Exercise - 2

1. (i) $x = 2$, $x = x = 2$, $x = -\frac{3}{2}$ are not roots of equation.
- (ii) $x = 2$ is a root of equation but $x = -3$ is not a root of equation.
- (iii) $x = -3$, $x = 4$ are not roots of equation.
- (iv) $x = 0$, $x = \frac{9}{4}$ are roots of equation.
- (v) $x = \sqrt{3}$ is a root of equation but $x = -2\sqrt{3}$ is not a root of equation.

2. (i) $x = 4, x = 2$ (ii) $x = -\frac{3}{2}, x = \frac{7}{3}$ (iii) $x = 7, x = 7$
 (iv) $x = 0, x = 11$ (v) $x = -12, x = -12$ (vi) $x = 0, x = -1$
3. $x = \sqrt{2}$ is not a root of equation.
4. (i) $x = \frac{2}{3}, x = -\frac{1}{3}$ (ii) $x = 0, x = -\frac{5}{4}$ (iii) $x = \frac{5}{3}, x = 2$
 (iv) $x = \frac{2}{5}, x = -1$ (v) $x = -\frac{2}{3}, x = -\frac{1}{2}$ (vi) $x = -\frac{2}{\sqrt{3}}, x = \frac{\sqrt{3}}{4}$
 (vii) $x = \frac{1}{2}, x = -\frac{1}{5}$ (viii) $x = 3\sqrt{2}, x = \sqrt{2}$
 (ix) $x = -\frac{b}{a}, x = \frac{c}{b}$ (x) $x = 5, x = -\frac{1}{5}$

Exercise - 3

1. (i) $\frac{-1+\sqrt{33}}{4}, \frac{-1-\sqrt{33}}{4}$ (ii) $\frac{-5}{3}, -2$ (iii) $\frac{3+\sqrt{19}}{5}, \frac{3-\sqrt{19}}{5}$
 (iv) $\sqrt{2}, 3\sqrt{2}$ (v) $\frac{1}{3}, -1$ (vi) 3, 1
2. $\frac{1+\sqrt{29}}{2}, \frac{1-\sqrt{29}}{2}$ 3. Consecutive natural numbers 6, 7
4. Consecutive natural numbers 4, 5 5. Numbers 36, 12
6. Length of base = 15 meter, length of perpendicular = 22 meter
7. 21 meter, 17 meter 8. Rupees 250
9. 36 years, 9 years 10. 13 years
11. 16 students 12. 12, 28 or 21, 19

Exercise - 4

1. (i) 8 (ii) 1 (iii) 32 (iv) $16-4a$ (v) p^2-4q
2. (i) Real and equal roots (ii) Roots are not real
 (iii) Real and equal roots (iv) Real and different roots
 (v) Roots not real

3. (i) $k = \frac{25}{2}$ (ii) $k = \pm \frac{5}{2}$ (iii) $k = \pm 3$
 (iv) $k = \pm 24$ (vi) $k = 4$
4. (i) $\frac{2}{9}, -1$ (ii) $\frac{1}{2}, -\frac{2}{3}$ (iii) $-2, \frac{5}{6}$ (iv) $\frac{7}{2}, 1$
 (v) $\frac{1}{2}(7 + \sqrt{69}), \frac{1}{2}(7 - \sqrt{69})$ (vi) $-4, \frac{1}{3}$ (vii) $\frac{2}{3}, \frac{-2}{3}$
 (viii) $\frac{12}{\sqrt{3}}, \frac{-2}{\sqrt{3}}$ (ix) $-2, \frac{3}{2}$ (x) $\frac{\sqrt{6}}{2}$

Exercise - 5

1. (i) $x^2 + 4x - 12 = 0$ (ii) $x^2 - 6x - 9 = 0$
 (iii) $x^2 - 2\sqrt{7}x + 8 = 0$ (iv) $9x^2 - 4x + 9 = 0$
2. (i) $x^2 - 11x + 28 = 0$ (ii) $x^2 - 16x + 55 = 0$
 (iii) $x^2 - 2x - 8 = 0$ (iv) $x^2 + 12x - 288 = 0$
 (v) $x^2 - \frac{1}{5}x - \frac{12}{25} = 0$ (vi) $x^2 - 8x + 16 = 0$
 (vii) $15x^2 - x - 2 = 0$ (viii) $x^2 - 11x + 24 = 0$
 (ix) $x^2 - 2\sqrt{3}x - 46 = 0$ (x) $x^2 - 12x + 31 = 0$
3. (i) $\frac{-7}{3}, \frac{1}{3}$ (ii) $1, \frac{3}{2}$ (iii) $\frac{5}{3}, \frac{-2}{3}$
 (iv) $\sqrt{6}, \frac{3}{2}$ (v) $-6, -6$



ARITHMETIC PROGRESSION

Number patterns

Look at the following numbers:-

2, 4, 6, 8, 10,

Do you see some order or pattern in these numbers?

Salma - Here, every number is 2 less than the next number.

Mohan - Here, every number is a successive multiple of 2. On multiplying 2 by 1, we get 2, on multiplying 2 by 2 we get 4, on multiplying 2 by 3 we get 6 and so on.....

John - Here, the second number 4 is two times of the first number 2, third number 6 is one and a half times of second number 4 and so on.

You can see that we will need a different rule for every number in John's pattern while in the patterns of Salma and Mohan all numbers will be formed by a single rule.

Look at the numbers given below:-

6, 11, 16, 21, -----

You can say that except for the first number, each number is formed by adding 5 to the previous number.

Can you see any other pattern in this (Discuss)?

Following are some more examples of numbers:

1. -5, -7, -9, -11, -13,
2. 4, 9, 14, 19,
3. 3, 7, 11, 15,

What is a series?

You can see that numbers in each of the series given above increase or decrease by a certain amount from the previous number, for example, numbers decrease by 2 in the first series, increase by 5 in the second series and increase by 4 in the third series. These types of number series in which there is a certain relation between successive numbers are known as progressions.

Try These



Find out the pattern in each of the given progressions:-

- (1) 4, 10, 16, 22,
- (2) 0, 3, 6, 9,
- (3) -1, -3, -5, -7,

Arithmetic progressions

You saw that in the series given above except the first term, each term is formed by adding a certain number to the previous term. These types of series of numbers are called Arithmetic Progressions or A.P. and the certain number added to each term is called common difference of the arithmetic progression. Common difference can be positive, negative or zero.

Look at the number series given below:

8, 13, 18, 23,

The first term of this series is 8, the second term is 13, the third term is 18 and the fourth term is 23. Here, we get the next term by adding 5 to the previous term. Therefore, the common difference of this progression is 5.

Example-1. Find the first term, the fourth term and the common difference for the given arithmetic progression.

-7, -11, -15, -19.....

Solution: First term = -7, Fourth term = -19

$$\begin{aligned} \text{Common difference} &= \text{Second term} - \text{First term} \\ &= -11 - (-7) \\ &= -11 + 7 \\ &= -4 \end{aligned}$$

Try These



1. Find out which of the following sequences are arithmetic progressions:-

- (i) 9, 16, 23, 30,
- (ii) 11, 15, 18, 20,
- (iii) 4, 13, 19, 28,
- (iv) 0, -3, -6, -9,
- (v) 2, 2, 2, 2,
- (vi) $9\frac{1}{7}, \frac{7}{7}, \frac{9}{7}, \frac{13}{7}, \dots$

2. Write the first term and the common difference for the given arithmetic progressions:-

(i) 9, 12, 15, 18,

(ii) 2, 8, 14, 20,

(iii) 3, -2, -7, -12,

(iv) -5, 2, 9, 16,

(v) 0.4, 0.9, 1.4, 1.9,

(vi) 5, 5, 5, 5,

(vii) $\frac{1}{3}, \frac{5}{3}, \frac{9}{3}, \frac{13}{3}, \dots$

Finding the next term:

An arithmetic progression is given below:-

3, 10, 17,

Can we extend the progression? How do we find the next term, i.e. the fourth term of this arithmetic progression?

Ajita - The fourth term is 24 which is obtained by adding the common difference 7 to the third term which is 17.

Now, write the next four terms i.e. The fifth, the sixth, the seventh and the eighth terms of this progression.

Fifth term		Seventh term	
Sixth term		Eighth term	

1. Find the next three terms of the arithmetic progressions given below:

(i) 5, 11, 17, 23,

(ii) -11, -8, -5, -2,

(iii) $\frac{4}{9}, \frac{7}{9}, \frac{10}{9}, \frac{13}{9}, \dots$

(iv) 0, 9, 18, 27,



Expressing an arithmetic progression in a general form

So far, we have seen many examples of arithmetic progressions. Each progression has a first term and a common difference. If we denote the first term by a and the common difference by d then we can find each term of an arithmetic progression using a and d . The second term of the arithmetic progression can be obtained by adding the common difference d to the first term, so that second term is $a + d$. In this way, by adding d to the second term ($a + d$), we can get the third term which will be $a + d + d$. We can write any arithmetic progression in the following way:

$$a, a + d, a + d + d, a + d + d + d, \dots$$

Or

$$a, a + d, a + 2d, a + 3d, \dots$$

This is called the generalized form of an arithmetic progression. When number of terms of the AP is finite it is said to be a finite arithmetic progression and when number of terms is infinite it is said to be an infinite arithmetic progression.

You can see that the number of terms in the arithmetic progression $-7, -11, -15, -19, \dots$ given in example (1) is infinite, therefore this is an infinite arithmetic progression.

Try These



1. Form an infinite arithmetic progression where the first term is 5 and common difference is 3.
2. Form two finite arithmetic progressions each having 5 terms.
3. If $a = 11$ and $d = 6$ in a finite arithmetic progression having 10 terms, then find the largest member of the series.

Note:- It is not necessary that the common difference should always be a natural number, it can be any real number.

Example-2. Write the first three terms of the arithmetic progression where the first term $a = 10$ and the common difference, $d = -3$.

Solution:

First term	$a = 10$
Common difference	$d = -3$
Second term	$= a + d$
	$= 10 + (-3)$
	$= 7$
Third term	$= a + 2d$

$$\begin{aligned}
 &= 10 + 2(-3) \\
 &= 10 - 6 \\
 &= 4
 \end{aligned}$$

Hence, the first three terms of the arithmetic progression are 10, 7, 4.

If we denote the common difference by d and the starting term or the first term of an AP by a_1 , the second term by a_2 , the third term by a_3 , the n^{th} term by a_n then the arithmetic progression can be expressed as $a_1, a_2, a_3, \dots, a_n$.

Here, the common difference can be expressed by $d = a_2 - a_1 = a_3 - a_2 = \dots = a_n - a_{n-1} = a_{n+1} - a_n$

Example-3. Sort the arithmetic progression from the following number series. Write the next two terms of the arithmetic progressions among the following.

- (i) 9, 27, 81,
- (ii) $4, 4 + \sqrt{3}, 4 + 2\sqrt{3}, 4 + 3\sqrt{3}, \dots$
- (iii) 1, -1, -3, -5,
- (iv) 0.2, 0.22, 0.222, 0.2222,

Solution: (i) $a_1 = 9, a_2 = 27, a_3 = 81$
 $a_2 - a_1 = 27 - 9 = 18$
 $a_3 - a_2 = 81 - 27 = 54$

Since, $a_3 - a_2 \neq a_2 - a_1$, therefore 9, 27, 81, is not an arithmetic progression.

- (ii) $a_1 = 4, a_2 = 4 + \sqrt{3}, a_3 = 4 + 2\sqrt{3}, a_4 = 4 + 3\sqrt{3}$,
 $a_2 - a_1 = 4 + \sqrt{3} - 4 = \sqrt{3}$
 $a_3 - a_2 = 4 + 2\sqrt{3} - (4 + \sqrt{3}) = \sqrt{3}$
 $a_4 - a_3 = 4 + 3\sqrt{3} - (4 + 2\sqrt{3}) = \sqrt{3}$

Since $(a_{k+1} - a_k)$, where $k = 1, 2, 3, \dots$ is same each time, therefore the given list of number is an arithmetic progression whose common difference is $d = \sqrt{3}$. The next two terms of progression are:

- $(4 + 3\sqrt{3}) + (\sqrt{3}) = 4 + 4\sqrt{3}$ and
 $(4 + 4\sqrt{3}) + (\sqrt{3}) = 4 + 5\sqrt{3}$
- (iii) $a_1 = 1, a_2 = -1, a_3 = -3, a_4 = -5$
 $a_2 - a_1 = -1 - 1 = -2$
 $a_3 - a_2 = -3 - (-1) = -2$
 $a_4 - a_3 = -5 - (-3) = -2$

Since $(a_{k+1} - a_k)$, where $k=1,2,3,\dots$ is same each time, therefore given list of number is an arithmetic progression whose common difference $d = -2$. Next two terms of progression are:-

$$-5 + (-2) = -7 \quad \text{and} \quad -7 + (-2) = -9$$

$$(iv) \quad a_1 = 0.2, a_2 = 0.22, a_3 = 0.222, a_4 = 0.2222$$

$$a_2 - a_1 = 0.22 - 0.2 = 0.02$$

$$a_3 - a_2 = 0.222 - 0.22 = 0.002$$

Since $a_3 - a_2 \neq a_2 - a_1$ therefore the given list of numbers is not an arithmetic progression.

n^{th} term of Arithmetic Progression

Suppose that $a_1, a_2, a_3, \dots, a_n$ is an arithmetic progression, whose first term is a and the common difference is d , then

$$\text{First term} \quad a_1 = a$$

$$\text{Second term} \quad a_2 = a + d = a + (2-1)d$$

$$\text{Third term} \quad a_3 = a + 2d = a + (3-1)d$$

$$\text{Fourth term} \quad a_4 = a + 3d = a + (4-1)d$$

$$\text{Fifth term} \quad a_5 = a + 4d = a + (5-1)d$$

By looking at the pattern we can say that

$$n^{\text{th}} \text{ term } a_n = a + (n-1)d$$

If there are m terms in an arithmetic progression, then a_m represents the last term.

The last term can also be denoted by l .

Let us try to understand by some examples:-

Example-4. Find the 10th term of the arithmetic progression 4, 7, 10, 13,

Solution: Here $a = 4$, $d = 7 - 4 = 3$ and $n = 10$

$$\begin{aligned} \therefore a_{10} &= a + (10-1)d && [\because n^{\text{th}} \text{ term, } a_n = a + (n-1)d] \\ &= 4 + 9 \times 3 \\ &= 4 + 27 \\ &= 31 \end{aligned}$$

Example-5. Arithmetic progression 2, 6, 10,, contains m terms. Find the last term.

Solution: Here the first term $a = 2$, the common difference $d = 6 - 2 = 4$ and the number of terms are m . Therefore the last term will be m . So $n = m$.

$$m^{\text{th}} \text{ term } a_m = a + (m-1)d$$

$$[\because \text{nth term, } a_n = a + (n-1)d]$$

$$a_m = 2 + (m-1)4$$

$$= 2 + 4m - 4$$

$$= 4m - 2$$

1. Arithmetic progression 3, 5, 7, contains 15 terms. Find the last term.
2. If the last term of the arithmetic progression -9, -5, -1, is 67, then how many terms are there in the progression?
3. Find the m^{th} and p^{th} terms of arithmetic progression 10, 15, 20,



Let us see some more examples:-

Example-6. Check whether 301 is a term in the AP 5, 11, 17, 23, Give reasons.

Solution:

$$\text{Here, } a = 5, \quad d = 11 - 5 = 6$$

$$\text{Let } n^{\text{th}} \text{ term be 301 i.e. } a_n = 301$$

We have to find the value of n

$$\therefore a_n = a + (n-1)d$$

$$301 = 5 + (n-1)6$$

$$301 = 5 + 6n - 6$$

$$301 = 6n - 1$$

$$6n = 302$$

$$n = \frac{302}{6}$$

$$n = \frac{151}{3}$$

Since number of terms is n , so the n^{th} term should be a positive whole number, but n is a fraction here. Therefore 301 is not a term of the given arithmetic progression.

Example-7. There are 50 terms in an arithmetic progression whose third term is 12 and the last term is 106. Find the 29th term of this arithmetic progression.

Solution:

Let the first term be a and the common difference be d in the given arithmetic progression

$$\text{Third term} = 12$$

$$a_3 = 12$$

$$a + (3-1)d = 12$$

$$a + 2d = 12 \dots\dots\dots (1)$$

and the last term = 106

$$50^{\text{th}} \text{ term} = 106$$

$$a_{50} = 106$$

$$a + (50-1)d = 106$$

$$a + 49d = 106 \dots\dots\dots (2)$$

By subtracting (1) from (2)

$$a + 49d = 106$$

$$a + 2d = 12$$

$$\begin{array}{r} - \quad - \quad - \\ \hline \end{array}$$

$$47d = 94$$

$$d = \frac{94}{47}$$

$$d = 2 \dots\dots\dots(3)$$

Putting the value of d from equation (3) in equation (1)

$$a + 2(2) = 12$$

$$a + 4 = 12$$

$$a = 12 - 4$$

$$a = 8 \dots\dots\dots(4)$$

$$\begin{aligned} 29^{\text{th}} \text{ term of the arithmetic progression} &= a + (29-1)d \\ &= 8 + (28)(2) \\ &= 8 + 56 \\ &= 64 \end{aligned}$$

Therefore, the 29th term of arithmetic progression is 64.

Try These



1. An arithmetic progression whose third term is 12 and the last term is 106, contains 50 terms. Find the 21st term of this arithmetic progression.
2. The first term of an arithmetic progression is 10 and common difference is -3. Find the 11th term.

Arithmetic progressions can be used to solve many daily life problems. Let us understand by some examples:-

Example-8. How many two digit numbers are divisible by 5?

Solution: The list of two digit numbers divisible by 5 is :-

10, 15, 20,, 95

This is an arithmetic progression, whose first term is $a = 10$, the common difference $d = 5$ and n^{th} term $a_n = 95$

Since n^{th} term

$$95 = 10 + (n-1) \cdot 5$$

$$95 = 10 + 5n - 5$$

$$95 = 5 + 5n$$

$$5n = 95 - 5$$

$$n = \frac{90}{5}$$

$$n = 18$$

Therefore, 18 two digit numbers are divisible by 5.

Example-9. Jyoti started to work in 1997 at a monthly salary of Rs.5000 and gets an annual increment of Rs.200 in her salary. In which year did her salary become Rs.7000/-?

Solution:

Monthly salaries (in ₹) for years 1997, 1998, 1999, 2000are
5000, 5200, 5400, 5600.....

This is an A.P., because difference of any two successive terms is 200, therefore the common difference $d = 200$ and the first term $a = 5000$.

Suppose that Jyoti's salary becomes 7000 in n years.

Then,

$$a_n = 7000$$

$$a + (n - 1)d = 7000$$

$$5000 + (n-1) 200 = 7000$$

$$(n-1) 200 = 7000 - 5000$$

$$(n-1) 200 = 2000$$

$$n - 1 = \frac{2000}{200}$$

$$n - 1 = 10$$

$$n = 11$$

Therefore in eleventh year i.e. in 2007 Jyoti's salary will become Rs.7000.

Till now you have solved examples in which series of numbers formed arithmetic progressions. Now we will solve examples where letter combinations (p, q, r etc.) form arithmetic progressions.

Example-10. If in an arithmetic progression the p^{th} term is q and the q^{th} term is p, then find the m^{th} term.

Solution:

Let the first term be a and the common difference be d of the arithmetic progression.

Now,

$$\begin{aligned} p^{\text{th}} \text{ term of the arithmetic progression} &= q \\ \therefore a + (p-1)d &= q \dots\dots\dots(1) \end{aligned}$$

$$\begin{aligned} q^{\text{th}} \text{ term of the arithmetic progression} &= p \\ \therefore a + (q-1)d &= p \dots\dots\dots(2) \end{aligned}$$

By subtracting (2) from (1)

$$a + (p-1)d = q$$

$$a + (q-1)d = p$$

By subtracting $\quad - \quad - \quad -$

$$[(p-1) - (q-1)]d = q - p$$

$$[p-1-q+1]d = q-p$$

$$(p-q)d = q-p$$

$$d = \frac{-(p-q)}{(p-q)}$$

$$d = -1 \quad \dots\dots(3)$$

Putting the value of d from equation (3) in (1)

$$a + (p-1)(-1) = q$$

$$a = q + (p-1)$$

$$a = q + p - 1 \quad \dots\dots(4)$$

$$\begin{aligned} m^{\text{th}} \text{ term of the progression } a_m &= a + (m-1)d \\ &= (p+q-1) + (m-1)(-1) \\ &= p + q - 1 - m + 1 \\ &= p + q - m \end{aligned}$$

Therefore, m^{th} term of the progression $= p + q - m$

Q.1 Choose the correct option and give reasons:

(i) First term and common difference of given arithmetic progression are:-

$$\frac{3}{2}, \frac{1}{2}, -\frac{1}{2}, -\frac{3}{2}, \dots$$

(a) $\frac{1}{2}, -\frac{1}{2}$ (b) $\frac{3}{2}, -1$ (c) $\frac{3}{2}, -\frac{1}{2}$ (d) $-\frac{3}{2}, -1$

(ii) If first term is -2 and common difference is -2 for an arithmetic progression, then fourth term is _____.

(a) 0 (b) -2 (c) -4 (d) -8

(iii) 15th term in the arithmetic progression 7, 13, 19, is

(a) 91 (b) 97 (c) 112 (d) 90

(iv) First term is 4 and common difference is -4 of an arithmetic progression, then nth term is:-

(a) $8 - 2n$ (b) $4 - 2n$ (c) $8 - 4n$ (d) $8 - 8n$

(v) 78 is which term of arithmetic progression 3, 8, 13, 18,

(a) 15th (b) 16th (c) 17th (d) 18th

Q.2 Which is an arithmetic progression from the following progressions, give reasons:-

(a) a, a^2, a^3, a^4, \dots

(b) $\sqrt{2}, \sqrt{8}, \sqrt{18}, \sqrt{32}, \dots$

(c) $1^2, 3^2, 5^2, 7^2, 9^2, \dots$

(d) $0, -4, -8, -12, \dots$

(e) $16, 18\frac{1}{2}, 20\frac{1}{2}, 23, \dots$

Q.3 Find the 10th term of the arithmetic progression 9, 5, 1, -3,

Q.4 Find the 40th term of arithmetic progression 100, 70, 40,

Q.5 Find the nth term of the arithmetic progression $\frac{1}{9}, \frac{4}{9}, \frac{7}{9}, \dots$

Q.6 Find the mth term of arithmetic progression 950, 900, 850,

Q.7 Last term of the arithmetic progression 8, 15, 22, is 218. Find the number of terms.

Q.8 Which term is 0 of the AP 27, 24, 21,



- Q.9 Common difference of two arithmetic progressions is same. If the difference of their 99th terms is 99, then what will be the difference of their 999th term?
- Q.10 In a flower bed there are 23 rose plants in the first row, 21 in the second, 19 in the third and so on. There are 5 rose plants in the last row. How many rows are there in the flower bed?
- Q.11 Sanjay saved Rs. 5 in the first week of a year and then increased his weekly savings by Rs. 1.75. If in the n th week, his weekly saving was Rs. 20.75, find n .
- Q.12 Is -47 a term of the arithmetic progression $18, 15\frac{1}{2}, 13, \dots$. If yes, then which term?
- Q.13 Find the 31st term of an arithmetic progression whose 11th term is 38 and the 16th term is 73.
- Q.14 Find the m th term of an Arithmetic progression whose 12th term exceeds the 5th term by 14 and the sum of both terms is 36.
- Q.15 Which term of the arithmetic progression 3, 15, 27, 39, will be 132 more than its 54th term?
- Q.16 The sum of the 4th and 8th terms of an arithmetic progression is 24 and the sum of the 6th and 10th terms is 44. Find the first three terms of the arithmetic progression.
- Q.17 How many three-digit numbers are divisible by 3?
- Q.18 Find the 10th term from the last in the arithmetic progression 3, 8, 13, 253.
- Q.19 If in an arithmetic progression p th term is $\frac{1}{q}$ and q th term is $\frac{1}{p}$, then prove that (pq) th term of arithmetic progression is 1.
- Q.20 If p th term is q and q th term is p of an arithmetic progression, then prove that $(p+q)$ th term is zero.
- Q.21 p th, q th and r th terms of an arithmetic progression are a , b , c respectively then prove that $a(q - r) + b(r - p) + c(p - q) = 0$.
- Q.22 For what value of n , the n th terms of two arithmetic progression 63, 65, 67, and 3, 10, 17, will be equal?

Arithmetic Mean

Suppose three quantities a, A, b are in arithmetic progression, then the middle quantity A is said to be arithmetic mean of the two quantities a and b .

Since a, A, b are in arithmetic progression.

therefore,

$$A - a = b - A$$

$$A + A = b + a$$

$$2A = a + b$$

$$A = \frac{a + b}{2}$$

Therefore, you can say that the arithmetic mean of two quantities is the half of the sum of those two quantities. Let us understand with the help of some examples:-

Example-11. Find the arithmetic mean of $\sqrt{2} + 1$ and $\sqrt{2} - 1$

Solution:

$$\begin{aligned} \text{Arithmetic mean} &= \frac{(\sqrt{2} + 1) + (\sqrt{2} - 1)}{2} \\ &= \frac{(\sqrt{2} + 1) + (\sqrt{2} - 1)}{2} \\ &= \frac{2\sqrt{2}}{2} \\ &= \sqrt{2} \end{aligned}$$

Forming an arithmetic progression between two quantities a and b

We can insert new numbers between any two numbers and form an AP. We will have to take the common difference d depending on the number of terms in the series. Suppose we want to insert n terms, $A_1, A_2, A_3, \dots, A_n$ between two values a and b . Then $a, A_1, A_2, A_3, \dots, A_n, b$ will form the AP where the first term is a , the last term is b and the number of terms is $(n+2)$.

Suppose the common difference of an arithmetic progression is d ,

then the last term $b = a + \overline{(n+2-1)}d$ [$\therefore n^{\text{th}}$ term, $a_n = a + (n-1)d$]

$$b = a + (n+1)d$$

$$b - a = (n+1)d$$

$$d = \frac{b - a}{n + 1}$$

therefore, $A_1 = a + d = a + \frac{b - a}{n + 1}$

$$A_2 = a + 2d = a + 2\left(\frac{b - a}{n + 1}\right)$$

$$A_3 = a + 3d = a + 3\left(\frac{b - a}{n + 1}\right)$$

By looking at the above pattern we can say that

$$n^{\text{th}} \text{ term} = A_n = a + nd = a + n \left(\frac{b-a}{n+1} \right)$$

Let us understand it by some examples:-

Example-12. Form an AP by inserting 3 terms between 11 and -5.

Solution:

Let A_1, A_2, A_3 be 3 terms between 11 and -5. Therefore 11, $A_1, A_2, A_3, -5$ are in an arithmetic progression. First term of this arithmetic progression is $a = 11$, 5th term = -5. Suppose common difference of the arithmetic progression is d .

$$5^{\text{th}} \text{ term} = a + 4d \quad [\because n^{\text{th}} \text{ term, } a_n = a + (n-1)d]$$

$$-5 = 11 + 4d$$

$$-5 - 11 = 4d$$

$$4d = -16$$

$$d = \frac{-16}{4}$$

$$d = -4$$

$$\begin{aligned} \text{Therefore, } A_1 &= a + d \\ &= 11 + (-4) \\ &= 7 \end{aligned}$$

$$\begin{aligned} A_2 &= a + 2d \\ &= 11 + 2(-4) \\ &= 11 - 8 \\ &= 3 \end{aligned}$$

$$\begin{aligned} A_3 &= a + 3d \\ &= 11 + 3(-4) \\ &= 11 - 12 \\ &= -1 \end{aligned}$$

Therefore, three terms between 11 and -5 are 7, 3, -1 which form the AP 11, 7, 3, -1, -5.

Example-13. n terms lie between 2 and 41. The ratio between the fourth term and the $(n-1)^{\text{th}}$ term is 2 : 5, then find the value of n .

Solution:

Suppose $A_1, A_2, A_3, \dots, A_n$ are n terms between 2 and 41. Therefore 2, $A_1, A_2, A_3, \dots, A_n, 41$ are in arithmetic progression, where the first term $a = 2$ and the $(n+2)^{\text{th}}$ term is 41.

Suppose common difference of progression is d .

then $(n + 2)^{\text{th}}$ term = 41

$$2 + (n + 2 - 1)d = 41$$

$$2 + (n + 1)d = 41$$

$$(n + 1)d = 41 - 2$$

$$d = \frac{39}{n + 1}$$

[n^{th} term $a_n = a + (n - 1)d$,]

According to the question

$$\frac{4^{\text{th}} \text{ term of the series } A_4}{n^{\text{th}} \text{ term of the series } A_{n-1}} = \frac{2}{5}$$

$$\frac{a + 4d}{a + (n - 1)d} = \frac{2}{5}$$

$$5a + 20d = 2a + 2(n - 1)d$$

$$5a - 2a = 2(n - 1)d - 20d$$

$$3a = (2n - 2)d - 20d$$

$$3a = (2n - 2 - 20)d$$

$$3a = (2n - 22)d$$

$$3(2) = (2n - 22) \left(\frac{39}{n + 1} \right)$$

(On putting the value of a and d)

$$6(n + 1) = 39(2n - 22)$$

$$6n + 6 = 78n - 858$$

$$6 + 858 = 78n - 6n$$

$$864 = 72n$$

$$n = \frac{864}{72}$$

$$n = 12$$

Exercise - 2

Q.1 Find the arithmetic mean of $\frac{1}{2}$ and $-\frac{1}{2}$

Q.2 Find the arithmetic mean of $x^2 + 3xy$ and $y^2 - 3xy$.

Q.3 Arithmetic mean and product of two numbers are 7 and 45 respectively. Find the numbers.



- Q.4 Arithmetic mean and sum of squares of two numbers are 6 and 90. Find the numbers.
- Q.5 Form an AP by inserting 6 terms between -4 and 10.
- Q.6 Form an AP by inserting 5 terms 11 and -7.
- Q.7 If in an arithmetic progression the mean of p^{th} and q^{th} term is equal to mean of r^{th} and s^{th} term then prove that $p + q = r + s$.
- Q.8 n terms lie between 7 and 49 in an AP. If ratio of the fourth term and the $(n - 1)^{\text{th}}$ term is 5 : 4, then find the value of n .

Sum of Arithmetic Progression

If the sum of the first three term of the arithmetic progression 5, 7, 9, 11, 13,is denoted by S_3 then,

$$S_3 = 5+7+9=21$$

To know the sum of the first four terms of this arithmetic progression we will add the first four terms i.e. 5, 7, 9 and 11. In this way we will get 32 as the sum of first four terms. But if you want to know the sum of first 90 terms of progression then you will have to add first 90 terms of progression. This process will be very long. If you want to know the sum of first n terms of an AP, you will use first term a , common difference d and no of terms n .

Suppose the first term of an arithmetic progression is a and the common difference is d . Therefore,

$$a, a+d, a+2d, \dots\dots\dots$$

is the arithmetic progression.

Suppose the sum of first three terms of the arithmetic progression is S_3 then,

$$S_3 = a+(a+d)+(a+2d) \quad \dots\dots(1)$$

If we write the sum of terms in the reverse order

$$S_3 = (a+2d)+(a+d)+a \quad \dots\dots(2)$$

By adding equation (1) and (2) according to terms

$$2S_3 = [a + (a + 2d)] + [(a + d) + (a + d)] + [(a + 2d) + a]$$

$$2S_3 = [2a + 2d] + [2a + 2d] + [2a + 2d]$$

$$2S_3 = 3[2a + 2d]$$

$$S_3 = \frac{3}{2}[2a + (3 - 1)d] \quad \dots\dots(3)$$

Suppose the sum of the first four terms is S_4 , then

$$S_4 = a+(a+d)+(a+2d)+(a+3d) \quad \dots\dots(4)$$

If we write the sum of terms in the reverse order

$$S_4 = (a+3d) + (a+2d) + (a+d) + a \quad \dots(5)$$

By adding equations (4) and (5) according to the terms

$$2S_4 = [a + (a + 3d)] + [(a + d) + (a + 2d)] + [(a + 2d) + (a + d)] + [(a + 3d) + a]$$

$$2S_4 = [2a+3d] + [2a+3d] + [2a+3d] + [2a+3d]$$

$$2S_4 = 4[2a + 3d]$$

$$S_4 = \frac{4}{2}[2a + (4 - 1)d] \quad \dots(6)$$

Similarly,

$$S_5 = \frac{5}{2}[2a + (5 - 1)d] \quad \dots(7)$$

$$S_6 = \frac{6}{2}[2a + (6 - 1)d] \quad \dots(8)$$

By looking at the pattern of equations (3), (6), (7), (8) we can say that in an arithmetic progression whose first term is a and the common difference is d , the sum of n terms S_n is given by:

$$S_n = \frac{n}{2}[2a + (n - 1)d]$$

Deduction Method for finding the sum

Suppose the first term is a and the common difference is d of an arithmetic progression, therefore

$$a, a+d, a+2d, \dots\dots\dots$$

is an arithmetic progression.

The n^{th} term of arithmetic progression is $a + (n - 1)d$. Let S_n be the sum of n terms of this arithmetic progression. Therefore,

$$S_n = a + (a+d) + (a+2d) + \dots\dots\dots + [a+(n-2)d] + [a+(n-1)d], \quad \dots(1)$$

If we write the terms in the reverse order-

$$S_n = [a+(n-1)d] + [a+(n-2)d] + \dots\dots\dots + (a+d) + a \quad \dots(2)$$

By adding equations (1) and (2) according to terms-

$$S_n + S_n = [a + a + (n - 1)d] + [(a + d) + a + (n - 2)d] +$$

$$[(a + 2d) + a + (n - 3)d] + \dots\dots\dots$$

$$\dots\dots\dots + [a + (n-2)d + (a+d)] + [a + (n-1)d + a]$$

$$2S_n = \{2a + (n-1)d\} + [2a + (n-1)d] + \dots\dots\dots + [2a + (n-1)d]$$

In the above equation, number of terms in the right side is n (Why?)

$$2S_n = n[2a + (n-1)d]$$

$$S_n = \frac{n}{2}[2a + (n-1)d]$$

Therefore sum of first n terms of arithmetic progression is

$$S_n = \frac{n}{2}[2a + (n-1)d]$$

This can also be written in the following way:-

$$S_n = \frac{n}{2}[a + a + (n-1)d]$$

$$= \frac{n}{2}[a + a_n]$$

If there are only n terms in an arithmetic progression, then the n^{th} term a_n is the last term i.e. $a_n = l$, here the letter l will be used for last term.

Sum of n terms of arithmetic progression in this condition will be given by:

$$S_n = \frac{n}{2}(a + l)$$



1. Is the n^{th} term of a progression is equal to the difference between sum of the first n terms (S_n) and sum of the first (n - 1) terms, (S_{n-1})?
2. If the sum of the first n terms of an arithmetic progression is $S_n = 4n - n^2$, then can you find the value of the first term? Is this S_1 ? What is the sum of first two terms of this arithmetic progression? What is the second term? In this way find the third, the fourth, the fifteenth and the n^{th} terms.

Example:-14. Find the sum of 17 terms of the arithmetic progression 5, 1, -3,

Solution:

Here, first term $a = 5$, common difference $d = 1 - 5 = -4$, number of terms $n = 17$.

We know that,

$$\begin{aligned}S_n &= \frac{n}{2} [2a + (n-1)d] \\S_{17} &= \frac{17}{2} [2(5) + (17-1)(-4)] \\&= \frac{17}{2} [10 + (16)(-4)] \\&= \frac{17}{2} (10 - 64) \\&= \frac{17}{2} (-54) \\&= -459\end{aligned}$$

Therefore, sum of first 17 terms of the given arithmetic progression is -459.

Example-15. Sum of first 14 term of an arithmetic progression is 1050 and its first term is 10, then find the 20th term.

Solution:

Here $a=10$, $n=14$, $S_{14}=1050$

We know that,

$$\begin{aligned}S_n &= \frac{n}{2} [2a + (n-1)d] \\1050 &= \frac{14}{2} [2(10) + (14-1)d] \\1050 &= 7 (20+13d) \\1050 &= 140 + 91d \\91d &= 1050 - 140 \\91d &= 910 \\d &= \frac{910}{91} \\d &= 10\end{aligned}$$

Therefore 20th term, $a_{20}=10+(20-1)(10)$

[\because nth term, $a_n=a+(n-1)d$]

$$a_{20}=10+190=200$$

Therefore 20th term is 200.

Example-16. Find the sum of all odd numbers between 100 and 200.

Solution:

Odd numbers between 100 and 200 are

101, 103, 105, -----199

This list of numbers is an arithmetic progression (Why?)

First term of this arithmetic progression is $a = 101$, last term $l = 199$, Common difference $d = 2$.

Suppose number of terms is n of this arithmetic progression, then

$$\begin{aligned}n^{\text{th}} \text{ term} &= 199 \\ a + (n-1)d &= 199 \\ 101 + (n-1)(2) &= 199 \\ 2n - 2 &= 199 - 101 \\ 2n - 2 &= 98 \\ 2n &= 98 + 2\end{aligned}$$

$$n = \frac{100}{2}$$

$$n = 50$$

Therefore, sum of odd numbers between 100 and 200

$$S_n = \frac{n}{2}(a+l)$$

$$\begin{aligned}S_{50} &= \frac{50}{2}(101+199) \\ &= 25(300) \\ &= 7500\end{aligned}$$

Therefore, sum of odd numbers between 100 and 200 is 7500.

Example-17. How many terms of arithmetic progression 17, 15, 13, must be taken to get a sum of 72.

Solution:

Here first term $a = 17$, common difference $d = 15 - 17 = -2$

Suppose sum of n term is 72, then $S_n = 72$.

We know that,

$$S_n = \frac{n}{2}[2a + (n-1)d]$$

$$72 = \frac{n}{2}[2(17) + (n-1)(-2)]$$

$$72 = \frac{n}{2}(34 - 2n + 2)$$

$$72 \times 2 = n(36 - 2n)$$

$$144 = 36n - 2n^2$$

$$2n^2 - 36n + 144 = 0$$

$$n^2 - 18n + 72 = 0$$

$$n^2 - 6n - 12n + 72 = 0$$

$$n(n-6) - 12(n-6) = 0$$

$$(n-6)(n-12) = 0$$

$$n=6, n=12,$$

Both values of n are possible and acceptable therefore the number of terms is either 6 or 12.

Comment:-

- (i) In this situation sum of first 6 term = sum of first 12 terms = 72
- (ii) Reason that there are two possible answers is that the sum of 7th term to 12th term is zero.

Example-18. In a school, students thought of planting trees in and around the school campus to reduce air pollution. It was decided that the number of trees that each section of each class would plant would be the same as the class in which they are studying, e.g., a section of class I would plant 1 tree, a section of class II would plant 2 trees and so on till class XII. There are three sections for each class. How many trees will be planted by the students?

Solution: Since there are three sections for each class, so number of trees planted by class I, Class II, Class III, Class XII respectively is given by:

$$1 \times 3, 2 \times 3, 3 \times 3, \dots, 12 \times 3$$

Or

$$3, 6, 9, \dots, 36$$

This is an arithmetic progression (Why?)

First term of this arithmetic progression $a = 3$, Common difference $d = 6 - 3 = 3$,

Number of terms $n = 12$, Last term $l = 36$

Therefore number of trees planted by school students will be equal to sum of all terms of the arithmetic progression. Thus,

Total Number of trees planted by school students

$$S_n = \frac{n}{2}(a + l)$$

$$\begin{aligned}
 S_{12} &= \frac{12}{2}(3+36) \\
 &= 6 \times 39 \\
 &= 234
 \end{aligned}$$

Therefore 234 plants are planted by the school students.

Example-19. A spiral is made up of successive semicircles of radii 0.5 cm, 1.0 cm., 1.5 cm., 2.0 cm....., with centers alternately at A and B, starting with center at A as shown in the figure. What is the total length of such a spiral made up of thirteen consecutive semicircles?

(Take $\pi = \frac{22}{7}$)

Solution:

We know that length of semicircle with radius r is πr .

Therefore, total length of a spiral made up of thirteen consecutive semicircles

$$= \pi (0.5) + \pi (1.0) + \pi (1.5) + \pi (2.0) + \dots + \pi (6.5)$$

$$= \pi(0.5)[1+2+3+\dots+13]$$

$$= \pi(0.5)\left[\frac{13}{2}\{2(1) + (13-1) \cdot 1\}\right]$$

$$= \pi(0.5)\left[\frac{13}{2}(2+12)\right]$$

$$= \pi(0.5)\left(\frac{13}{2} \times 14\right)$$

$$= \pi (0.5) (91)$$

$$= \frac{22}{7} \times \frac{5}{10} \times 91$$

$$= 143 \text{ cm}$$

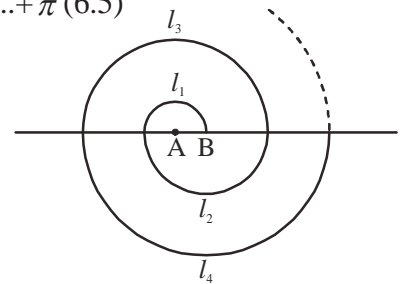

$1+2+3+\dots+13$ is an AP whose first term is 1, common difference is 1 and number of terms is 13.....

$$= \frac{n}{2}[2a + (n-1)d]$$

Therefore, total length of spiral made up of thirteen consecutive semicircles is 143cm.



Q.1 Find the sum of the following arithmetic progressions:-

- (i) 9, 12, 15, up to 16 terms.
- (ii) 8, 3, -2, up to 22 terms.
- (iii) 0.6, 1.7, 2.8, up to 100 terms.
- (iv) $\frac{1}{15}, \frac{1}{12}, \frac{1}{10}, \dots$ up to 11 terms.

(v) $\frac{n^2 + 1}{n}, n, \frac{n^2 - 1}{n}, \dots$ up to 20 terms.

(vi) $\left(1 - \frac{1}{n}\right), \left(1 - \frac{2}{n}\right), \left(1 - \frac{3}{n}\right), \dots$ up to n terms.

- Q.2 How many terms will it take to get the sum 1046.5 in AP 7, $10\frac{1}{2}$, 14,
- Q.3 How many terms of the arithmetic progression 24, 21, 18, must be taken so that their sum is 78?
- Q.4 First term of an arithmetic progress is 1, last term is 11 and sum 36. Find the number of terms and common difference.
- Q.5 First term is 17 and last term is 350 in an AP. If common difference is 9, then how many terms are in it? Find the sum of this progression.
- Q.6 Find the sum of all multiples of 3 natural numbers between 1 and 100.
- Q.7 Find the sum of all odd numbers lying between 0 and 50.
- Q.8 Find the sum of first 51 terms of that arithmetic progression whose second term 14 and third term is 18.
- Q.9 If the sum of first 7 terms of an arithmetic progression is 49 and that of 17 terms is 289, find the sum of first n terms.
- Q.10 If first, second and last terms are respectively a, b and 2a of an arithmetic progression, then prove that sum of progression will be $\frac{3ab}{2(b-a)}$
- Q.11 Sum of the first n terms of an arithmetic progression is $n^2 + 4n$. Find the 15th term of the progression.
- Q.12 Find the sum of first 24 terms of the list of numbers whose nth term is given by $a_n = 3 + 2n$.
- Q.13 Sum of pth, qth, rth terms of an arithmetic progression are a, b, c respectively, then prove that $\frac{a}{p}(q-r) + \frac{b}{q}(r-p) + \frac{c}{r}(p-q) = 0$
- Q.14 Sums of n term of three arithmetic progressions are s_1, s_2, s_3 respectively. If first term is 1 for every progression and common differences are 1, 2, 3 respectively then prove that $s_1 + s_3 = 2s_2$.
- Q.15 If the sum of n, 2n, 3n terms of an arithmetic progression are s_1, s_2, s_3 respectively then prove that $s_3 = 3(s_2 - s_1)$.
- Q.16 A manufacturer of TV sets produced 600 sets in the third year and 700 sets in the seventh year. Assuming that the production increases uniformly by a fixed number every year, find:

- (i) The number of TV sets produced in the 1st year.
- (ii) The number of TV sets produced in the 9th year.
- (iii) The total production in first 7 years.

- Q.17 A contract on construction job specifies a penalty for delay of completion beyond a certain dates as follows : ₹ 200/- for the first day, ₹ 250/- for the second day, ₹ 300/- for the third day, etc., the penalty for each successive day being ₹ 50/- more than the preceding day. How much money will the contractor have to pay as penalty if he has delayed the work by 30 days?
- Q.18 A sum of ₹ 700/- is to be used to give seven cash prizes to students of a school for their overall academic performance. If each prize is ₹ 10/- less than its preceding prize, find the value of each of the prizes.
- Q.19 200 logs are stacked in the following manner : 20 logs in the bottom row, 19 in the next row, 18 in the row next to it and so on (see fig.)



Find out in how many rows are the 200 logs placed and how many logs are in the top row?

- Q.20 In a potato race, a bucket is placed at the starting point, which is 5 m from the first potato and the other potatoes are placed 3 m apart in a straight line. There are ten potatoes in the line (See. fig.)



A competitor starts from the bucket, picks up the nearest potato, runs back with it, drops it in the bucket, runs back to pick up the next potato, runs to the bucket to drop it in, and she continues in the same way until all the potatoes are in the bucket. What is the total distance the competitor has to run?

[Hint: To pick up the first potato and the second potato, the total distance run by a competitor is $(2 \times 5) + 2(5 + 3)$.

What We Have Learnt

1. An Arithmetic Progression (AP) is a list of numbers in which each term except the first term is obtained by adding a fixed number d to the preceding term. The fixed number d is called the common difference. If first term is a , then the general form of an arithmetic progression is

$$a, a + d, a + 2d, a + 3d, \dots$$

2. A given list of numbers a_1, a_2, a_3, \dots is an arithmetic progression if the differences $a_2 - a_1, a_3 - a_2, a_4 - a_3, \dots$ give the same value, i.e. the value of $a_{k+1} - a_k$ is the same, where $k = 1, 2, 3, \dots$

3. First term is a and common difference is d of an arithmetic progression, then n^{th} term of this arithmetic progression-

$$a_n = a + (n - 1) d$$

This n^{th} term of the arithmetic progression is known as the general term.

4. If a, A, b are in arithmetic progression, then $A = \frac{a+b}{2}$ and A is said to be arithmetic mean of a and b .

5. If n terms $A_1, A_2, A_3, \dots, A_n$, are taken between two terms a and b such that $a, A_1, A_2, A_3, \dots, A_n, b$ are in arithmetic progression whose first term is a , last term is b and the number of term is $(n + 2)$.

6. The sum S_n of n term of an arithmetic progression can be obtained by using the following formulae:

$$(i) \quad S_n = \frac{n}{2} [2a + (n-1)d]$$

$$(ii) \quad S_n = \frac{n}{2} [a + l]$$

where the first term of arithmetic progression is a , the common difference is d , the number of terms is n and the last term is l .



ANSWER KEY

Exercise-1

- | | | | |
|---------------------------------|------------------|---------------------------|----------------------|
| (1) (i) (b) | (ii) (d) | (iii) (a) | (iv) (c) |
| (v) (b) | | | |
| (2) (b), (d) | (3) -27 | (4) -1070 | (5) $\frac{3n-2}{9}$ |
| (6) $1000 - 50m$ | (7) 31 | (8) 10 th term | |
| (9) 99 | (10) 10 | (11) 10 | |
| (12) Yes, 27 th term | (13) 178 | (14) $2m+1$ | |
| (15) 65 th term | (16) -13, -8, -3 | (17) 300 | |
| (18) 208 | (22) 13 | | |

Exercise-2

- | | | |
|-------------|---------------------------|---------------------|
| (1) 0 | (2) $\frac{x^2 + y^2}{2}$ | (3) 5 and 9 |
| (4) 3, 9 | (5) -2, 0, 2, 4, 6, 8 | (6) 8, 5, 2, -1, -4 |
| (8) $n = 5$ | | |

Exercise-3

- | | | | |
|---|---|-------------------------|----------------------|
| (1) (i) 504 | (ii) -979 | (iii) 5505 | (iv) $\frac{33}{20}$ |
| (v) $\frac{10(2n^2 - 17)}{n}$ | | (vi) $\frac{1}{2}(n-1)$ | |
| (2) 23 | (3) 4 or 13 | (4) $n = 6, d = 2$ | |
| (5) 38, 6973 | (6) 1683 | (7) 625 | |
| (8) 5610 | (9) n^2 | (11) 33 | |
| (12) 672 | (16) (i) 550 | (ii) 750 | (iii) 4375 |
| (17) ₹ 27750 | (18) Amount of prizes (in ₹) 130, 120, 110, 100, 90, 80, 70 | | |
| (19) 16 rows, 5 logs are kept in the top row. | | | |

Hint: $S = 200, a = 20, d = -1$, substituting in the formula $S_n = \frac{n}{2}[2a + (n-1)d]$ we get two value of n , 16 and 25. Now $a_{25} = a + 24d = -4$ i.e. number of logs in 25th row is negative, which is not possible. So $n = 25$ is not acceptable. For $n = 16, a_{16} = a + 15d = 5$, so the number of rows is 16 and 5 logs are kept in the top row.

- (20) 370 meter.

RATIO AND PROPORTION

CHAPTER

05

Ratio

Often we find the need to compare different quantities in our work. Sometimes, this comparison requires us to take ratio of the quantities. For example, suppose we want to compare three Kabbaddi teams A, B and C in any given year. How do we do it?

We have been told that team A has played 5 matches and won 3. Team B has played 12 matches and won 5 and team C has played 18 matches and won 13.

To find out which team is best performing, we should write the ratio of matches won to total matches played for each team.

$$\begin{aligned}\text{Performance of team A (in ratio)} &= 3:5 \\ &= \frac{3}{5}\end{aligned}$$

$$\begin{aligned}\text{Performance of team B (in ratio)} &= 5:12 \\ &= \frac{5}{12}\end{aligned}$$

$$\begin{aligned}\text{Performance of team C (in ratio)} &= 13:18 \\ &= \frac{13}{18}\end{aligned}$$

But we can't say which team is best on the basis of these ratios because the number of matches won and the number of matches played is different for each team and therefore the denominators are different. We should make the denominator common in all ratios. On doing this:

$$\text{Performance of team A} = \frac{3 \times 36}{5 \times 36} = \frac{108}{180}$$

$$\text{Performance of team B} = \frac{5 \times 15}{12 \times 15} = \frac{75}{180}$$

$$\text{Performance of team C} = \frac{13 \times 10}{18 \times 10} = \frac{130}{180}$$

By looking at these figures we can say that team C was the best performing team.

Try these



The area of which of the following smaller plots is biggest as compared to the main plot -

- (a) 5 cm square from 5 meter square
- (b) 3 cm square from 30 meter square
- (c) 9 cm square from 10 meter square

Practical uses of ratios

Getting information from given statements

Often, we draw conclusions from given facts. For example, we know that the total surface area of earth is 510 million square kilometers, of which almost 360 million square kilometers is water and 150 million square kilometers is land. On the basis of these figures we can find out the ratio of water to land on the surface of the earth and also the percentage of surface of earth covered by water and the percentage which is land.

Given facts and figures

- (i) The total surface area of earth is 510 million square kilometers
- (ii) Area covered by water is 360 million square kilometers
- (iii) Area covered by land is 150 million square kilometers
- (A) Ratio of water to land on the surface of earth = 360 : 150

$$\begin{aligned} &= \frac{360}{150} \\ &= \frac{12}{5} \text{ or } 12 : 5 \end{aligned}$$

The ratio of water to land on the surface of earth is 12:5.

$$\begin{aligned} \text{(B) Ratio of area covered by water to total surface area} &= 360 : 510 \\ &= \frac{360}{510} = \frac{12}{17} = 12 : 17 \\ \text{In percentage} &= \frac{360}{510} \times 100\% \\ &= 70.58\% \end{aligned}$$

Similarly, we can find out the percentage of earth's surface which is land.

In the example taken above, we compared the performance of three teams. We can also look at the performance of the same team in different years. Let us understand through an example-

Example-1: The performance of the State Hockey team of Chhattisgarh in national level matches is shown below:

1. Played 12 matches in 2016 and won 10.
2. Played 10 matches in 2015 and won 7.
3. Played 11 matches in 2014 and won 8.

From the given data for three years, tell in which year did the team play best? Explain giving reasons.

Solution: To conclude from the performance data given, we need to first convert into ratios and then percentages.

1. Performance in year 2016 (in ratio) = 10:12
 In percentage = $\frac{10}{12} \times 100\%$
 = 83.34%
2. Performance in 2015 (in ratio) = 7:10
 In percentage = $\frac{7}{10} \times 100\%$
 = 70%
3. Performance in 2014 (in ratio) = 8:11
 In percentage = $\frac{8}{11} \times 100\%$
 = 72.73%

The performance of the team in the years 2016, 2015 and 2014 was 83.34%, 70% and 72.73% respectively. Therefore, we can conclude that the team performed better in 2016 as compared to the previous two years.

Example-2. The water-level in the river Mahanadi increased 5 inches per hour on an average in the month of August whereas it increased 3 feet per day on an average in the month of September. Find out the month in which the increase in water level was more.

Solution: Rate of increase in water level in the month of August = 5 inches per hour
 Rate of increase in water level in the month of September = 3 feet per day
 = 36 inches per 24 hours
 = 1.5 inches per hour
 = $\frac{36 \text{ inch}}{24 \text{ hour}}$

$$= \frac{1.5 \text{ inch}}{1 \text{ hour}}$$

$$= 1.5 \text{ inch per hour}$$

Rate of increase in water level in the month of September is 1.5 inches per hour which is less than the rate of increase in water level in the month of August, 5 inches per hour.

Example-3. Two groups complete a given task in 14 and 21 days respectively. How long would they take to complete the task if they work together?

Solution: Let the work done by group one in 14 days = 1

$$\text{Therefore, the work done by group one in 1 day} = \frac{1}{14}$$

Similarly, the work done by group two in 21 days = 1

$$\text{Therefore, the work done by group two in 1 day} = \frac{1}{21}$$

$$\text{Total work done by the two groups in one day} = \frac{1}{14} + \frac{1}{21} = \frac{5}{42}$$

That is, the two groups together complete $\frac{5}{42}$ work in 1 day.

$$\text{Thus, the two groups together complete the task in } \frac{5}{42} \text{ days} = 8\frac{2}{5}$$

Exercises - 1



1. In a cricket match, batsman Dheerendra scores 19 runs in 25 balls and gets out, Mahendra scores 14 runs in 19 balls and is sent back to the pavilion and Ravindra scores 9 runs in 16 balls. Who scored fastest and who was the slowest?
2. In a 100 m race, Ram runs at a speed of 12 km per hour leaving Shyam 5 meters behind. What was Shyam's speed?
3. The volume of salt water on earth is 38214 million cubic kilometers and that of fresh water is 1386 million cubic kilometers. Tell the ratio of fresh water to salt water on earth? What is the percentage of fresh water on earth? And the percentage of salt water?
4. Mahesh cuts the paddy crop in a field in 12 days. Gayatri cuts the same crop in 9 days. How many days would be needed to cut the crop if they both work together?
5. Arun and Ashwini complete a task by themselves in 20 and 25 days respectively. Can you tell the percentage by which Arun works more efficiently than Ashwini?
6. Sanjay and Shiva together complete a task in 16 days. Sanjay takes 24 days to complete the task when he works alone. How many days will Shiva take to complete the task when he works alone?

Dividing into two or more parts

Often we need to divide a quantity into two or more parts. In dividing into more than two parts we come across three situations. First, we may have to divide into three equal parts. We can easily find out how much each person will get. Second, we may have to divide in such a manner that the first person gets more than the second who gets more than the third. And in third situation we may have to divide the quantity in a certain ratio, for example, dividing some money between three persons in the ratio a:b:c.

An example of dividing in a fixed ratio

Three friends Lata, Sonu and Purendra started a business worth Rs.15 lacs by contributing Rs.3 lacs, Rs.5 lacs and Rs.7 lacs respectively. At the end of the year, they earned a profit of Rs.2,25,000. What would be each person's share in the profit? Will each person get the same share of profit? If not, then how the profit should be divided? Let us see. Since, each person contributed different amounts to the business therefore the profit should be divided accordingly. The initial contribution by the three was in the ratio 3:5:7. Therefore, they should respectively get 3k, 5k and 7k parts of the profit..

That is, $3k + 5k + 7k = 225000$

$$15k = 225000$$

$$k = \frac{225000}{15}$$

$$k = 15000$$

Thus, Lata will get 3k parts that is Rs.45000, of the profit.

Sonu will get 5k parts that is Rs.75000, of the profit.

And, Purendra will get 7k parts that is Rs.105000, of the profit.

What will be the distribution process in the following three situations?

- (i) Each person gets the same amount?
- (ii) One person gets 10 more than the other?
- (iii) When one gets in a fixed ratio?



Example:-4. If a 75cm long line segment is divided into three parts in the ratio 3:5:7 then what will be the length of each part?

Solution: On dividing a 75cm long line segment into three parts in the ratio 3:5:7 the length of each part would be 3k, 5k and 7k respectively.

Therefore, $3k + 5k + 7k = 75$

$$15k = 75$$

$$k = \frac{75}{15}$$

$$k = 5$$

Therefore, the length of one part will be $3k$ or 15 cm.

The length of second part will be $5k$ or 25 cm.

The length of third part will be $7k$ or 35 cm.

Try these



1. Divide Rs.651 between Amit, Anil and Ankita in such a way that for every one rupee that Amit gets, Anil gets Rs.5 and Ankita gets Rs.25.
2. Richa opened her piggybank and got Rs. 10, Rs.5, Rs.2 and Rs. 1 coins in the ratio 2:3:5:7. She told her mother that she now had Rs.520. Can you find out the number of each of the coins?

Example-5. Some money was distributed in the ratio 11:13:17 between three students A, B and C. If A got Rs.451 then find the amounts received by student B and student C. Also, find out the total money which was distributed.

Solution: Suppose A, B and C got Rs.11k, 13k and 17k respectively. If student A received Rs.451 then,

$$\text{Sum received by student A, } 11k = 451 \text{ that is } k = \frac{451}{11} = 41$$

We now know that the value of k is 41. Therefore, we can easily find out the share received by students B and C.

$$\text{Student B's share} = 13k = 13 \times 41 = \text{Rs. } 533$$

$$\text{Student C's share} = 17k = 17 \times 41 = \text{Rs. } 697.$$

$$\begin{aligned} \text{Total money distributed between students A, B and C} &= 451 + 533 + 697 \\ &= 1681. \end{aligned}$$

Example-6. Can Rs. 63 thousand be distributed in the ratio 5:7:9 between students A, B and C so that they only receive Rs.500 notes? If yes, then find the amount received by each student.

Solution: When Rs. 63 thousand is distributed between students A, B and C, they will get $5k$, $7k$ and $9k$ respectively.

$$\text{That is, } 5k + 7k + 9k = 63 \text{ thousand}$$

$$21k = 63 \text{ thousand or } k = \frac{63}{21} \text{ thousand} = 3 \text{ thousand}$$

Thus, Student A gets = $5k = 5 \times 3 = 15$ thousand

Student B gets = $7k = 7 \times 3 = 21$ thousand

Student C gets = $9k = 9 \times 3 = 27$ thousand

These amounts can be distributed solely in Rs.500 notes

Example-7. In a business partnership, contributing share of businessmen A and B is in the ratio 3:2 and that of A and C is in the ratio 2:1. A, B and C earn a profit of Rs.178,100 in their business. How much will each of them get individually?

Solution: Since contributing share of businessmen A and B is in the ratio 3:2 and that of A and C is in the ratio 2:1 therefore to get the mutual ratio we will have to get equivalent ratios with A. To do this, we will look at the ratio between businessmen B and A. The ratio is 2:3 or 4:6. Contributing ratio between businessmen A and C is 2:1 or 6:3. Thus, contributing ratios of businessmen B, A and C are 4:6:3.

Profit will be distributed in the ratio 4:6:3 of their contributing shares. Therefore, they will get 4k, 6k and 3k of the profit respectively.

$$\text{So, } 4k + 6k + 3k = 178100$$

$$13k = 178100$$

$$k = \frac{178100}{13}$$

$$k = 13700$$

Thus, Profit received by A is 6k that is, Rs.82200.

Profit received by B is 4k that is, Rs.54800.

Profit received by C is 3k that is, Rs.41100.

Try this

1. Sita has Rs.8200 where the number of Rs.500 notes is twice that of Rs.100 and the number of Rs.1000 notes is three times that of Rs.100. Find the number of Rs.1000 notes with Sita.
2. Divide Rs. 2890 between A, B and C such that A:B = 1:2 and B:C = 3:4.



Dividing a quantity in any ratio

Divide a quantity x into three parts such that the ratio between the parts is $a:b:c$. Here, x can be of any value and type and a, b, c can be any natural numbers.

We have to divide the quantity x in the ratio $a:b:c$. We can write this as follows:

$$ak + bk + ck = x$$

$$(a + b + c)k = x$$

$$k = \frac{x}{(a+b+c)}$$

Therefore, the first part of x is ak that is $\frac{ax}{(a+b+c)}$

the second part of x is bk that is $\frac{bx}{(a+b+c)}$

the third part of x is ck that is $\frac{cx}{(a+b+c)}$

We found that the three quantities obtained after distribution are respectively

$$\frac{ax}{(a+b+c)}, \frac{bx}{(a+b+c)} \text{ and } \frac{cx}{(a+b+c)}$$

Example-8. Suppose we have 40 liters of a mixture of milk and water which is 10% water. The milk seller added some more water to this mixture. The new mixture has 20% water. How much more water was added?

Solution: Water in original mixture = 10% of 40 liters = 4 liters

And milk = 40 - 4 = 36 liters.

Suppose x liters of water is added to this mixture.

Then water in the new mixture = $(4+x)$ liters

And milk = 36 liters.

Given that ratio of water to milk in the new mixture is 20% and 80%

Ratio of water to milk = 20 : 80 = 1 : 4

$$\text{Thus, } \frac{4+x}{36} = \frac{1}{4}$$

$$16 + 4x = 36$$

$$x = 5$$

So 5 liters of water were added to the original mixture.

- The runs scored by three batsmen A, B and C in a cricket match are in the ratio $A:B:C = 1:2$. If the total of their runs is 364 then find the runs scored individually by each batsman.
- The salaries of three workers A, B and C are in the ratio 2:3:5. If their salaries are respectively increased by 15%, 10% and 20% then what will be the ratio of their new salaries?
- Three persons earn a profit of Rs. 70,000 in a business which they to divide in the ratio $A:B = 4:2$ and $B:C = 10:5$. How much money will each person get? The money received by A would be how many times the money received by C?
- A bag Rs. 1, Rs. 2 and Rs. 5 coins. If the coins are in the ratio 1:2:5 and the total money in the bag is Rs. 1590 then find the number of each type of coin.
- We have 100 liters of a mixture of milk and water which is 10% water. How much more pure milk should be added so that the new mixture has only 5% water?



Proportion

In class 9th exam, the marks scored by Maria in different subjects are as follows: $\frac{78}{100}$

in Hindi, $\frac{35}{50}$ in English, $\frac{30}{50}$ in Sanskrit, $\frac{70}{100}$ in maths, $\frac{90}{100}$ in science and $\frac{72}{100}$ in social science. What can you say about Maria's performance in the different subjects?

To compare the different marks first the basic marks should be same in all subjects. That is if in English the marks are 35 out of 50 then they will be 70 out of 100 or we can write

$\frac{70}{100}$ as well.

Similarly, we can write the marks in Sanskrit as $\frac{30}{50} = \frac{2 \times 30}{2 \times 50} = \frac{60}{100}$

Now we can draw some conclusions.

Actually, $\frac{35}{50}$ and $\frac{70}{100}$ or $\frac{30}{50}$ and $\frac{60}{100}$ are equivalent ratios which means that the values of these ratios are same.

That is $\frac{35}{50} = \frac{70}{100}$ or $\frac{30}{50} = \frac{60}{100}$

The relation between two equivalent ratios is known as proportion.

If $a:b$ and $c:d$ are equal then we can write them as $a:b = c:d$ or we can also show them as $a : b :: c : d$.

Here, ':' is the symbol for proportion. And a, b, c and d are terms of the proportion. The first term is a and the fourth term is d and they are called the extreme terms. Similarly, c and b are known as the middle terms.

Therefore, if a, b, c and d are proportional then

$$\therefore \frac{a}{b} = \frac{c}{d}$$

$$\text{Or } ad = bc$$

This means that the product of the middle terms of a proportion is equal to the product of the extreme terms.

If we know any three of the four terms then we can find the value of the fourth term using the relation given above. Let us see a few examples-

Example-9. Find the fourth term of 7,3,21.

Solution: We have been given the first three terms and let the fourth term be x .

$$7 : 3 :: 21 : x$$

$$\Rightarrow \frac{7}{3} = \frac{21}{x}$$

$$\Rightarrow 7 \times x = 3 \times 21$$

$$\Rightarrow x = \frac{3 \times 21}{7}$$

$$\therefore x = 9$$

Therefore, the fourth term is 9.

Example-10. What should be subtracted from each of 54,71,75 and 99 so that the remaining terms are proportional.

Solution: Suppose we subtract y from each term.

$$\text{Then, } (54 - y) : (71 - y) :: (75 - y) : (99 - y)$$

$$\Rightarrow \frac{(54 - y)}{(71 - y)} = \frac{(75 - y)}{(99 - y)}$$

$$\Rightarrow (54 - y)(99 - y) = (75 - y)(71 - y)$$

$$\Rightarrow 5346 - 153x + y^2 = 5325 - 146x + y^2$$

$$\Rightarrow 153x - 146x = 5346 - 5325$$

$$\Rightarrow 7x = 21$$

$$\Rightarrow x = \frac{21}{7}$$

$$\Rightarrow x = 3$$

That is, if we subtract 3 from each term then the resulting terms will be proportional. Check for yourself.

Continued proportion

Quantities where the ratio between the first and second term is the same as the ratio between the second and third term which is the same as the ratio between the third and fourth term and so on.

That is, if a, b, c, d, \dots are the quantities then and $\frac{a}{b} = \frac{b}{c} = \frac{c}{d} = \frac{d}{e} \dots$ then they are in continued proportion.

Since $a:b:c$ then b is the mean proportional of a and c , that is, $a : b :: b : c$

$$\text{Or } \frac{a}{b} = \frac{b}{c}$$

$$\Rightarrow b^2 = ac$$

$$\Rightarrow b = \pm\sqrt{ac}$$

Thus, we can find the value of the middle term.

Example-11. Find the mean proportional of 6 and 54.

Solution: Suppose x is the mean proportional of 6 and 54.

$$\text{Then } 6 : x :: x : 54$$

$$\Rightarrow x \times x = 6 \times 54$$

$$\Rightarrow x^2 = 6 \times 6 \times 3 \times 3$$

$$\Rightarrow x = \sqrt{6 \times 6 \times 3 \times 3}$$

$$\Rightarrow x = 6 \times 3 = 18$$

Thus, 18 is the mean proportional of 6 and 54.

Example-12. Find the third proportional of $8xy$ and $4x^2y$.

Solution: Suppose m is the third proportional of $8xy$ and $4x^2y$, then

$$8xy : 4x^2y : m \Rightarrow 8xy : 4x^2y :: 4x^2y : m$$

$$\Rightarrow \frac{8xy}{4x^2y} = \frac{4x^2y}{m} \Rightarrow 8xy \times m = 4x^2y \times 4x^2y$$

$$\Rightarrow m = \frac{4x^2y \times 4x^2y}{8xy} \Rightarrow m = 2x^3y$$

Thus, the third proportional is $2x^3y$.

Example-13. If $a : b :: c : d$ then prove that

$$\frac{d^2 - c^2}{b^2 - d^2} = \frac{ac}{bd}$$

Solution: Let $\frac{a}{b} = \frac{c}{d} = k$

So, $a = bk, \quad c = dk$

$$\begin{aligned} \text{L.H.S.} &= \frac{a^2 - c^2}{b^2 - d^2} \\ &= \frac{(bk)^2 - (dk)^2}{b^2 - d^2} \\ &= \frac{k^2(b^2 - d^2)}{(b^2 - d^2)} \\ &= k^2 \quad \dots\dots\dots(1) \end{aligned}$$

$$\begin{aligned} \text{R. H. S.} &= \frac{ac}{bd} \\ &= \frac{bk \cdot dk}{bd} \\ &= \frac{k^2(bd)}{bd} \\ &= k^2 \quad \dots\dots\dots(2) \end{aligned}$$

From (1) and (2), we can say that

$$\frac{a^2 - c^2}{b^2 - d^2} = \frac{ac}{bd}$$

$$\text{L.H.S.} = \text{R.H.S.}$$

Inverse Proportion

We know that the quantity of goods purchased using a fixed amount of money decreases as the cost increases. On the other hand, the quantity increases if rates are slashed. If we increase (or decrease) the speed of a cycle or a bus or a car then the time taken to cover the same distance decreases (or increases). Similarly, the time taken to carry out some work increases or decreases depending on whether we decrease or increase the number of workers. All these are inverse proportions or relations.

Think and Discuss

Think of some more examples of inverse proportions or inverse relations.



Inverse proportions have several applications. Let us see some examples.

Example-14. 12 labourers working 8 hours a day can finish a piece of wall in 9 days. If 24 labourers work 6 hours a day, then the days required to finish the same piece of wall will be how many?

Solution: The number of labourers and the time taken to complete the wall are inversely related to each other. 12 labourers take $8 \times 9 = 72$ hours to complete the task.

If the number of labourers is increased to 24 and the number of work hours is decreased to 6 and supposing that the days taken to complete the wall are x then time taken = 6 hours $\times x = 6x$ hours.

Since, work was completed under both conditions therefore there is an inverse relation between the number of labourers and the time taken which we can write as follows:

number of labourers	number of labourers	::	time taken (in hrs)	time taken(in hrs)
12	24	::	6x	72

$$\Rightarrow \frac{12}{24} = \frac{6x}{72}$$

$$\Rightarrow 72 \times 12 = 6x \times 24$$

$$\Rightarrow x = \frac{72 \times 12}{24 \times 6}$$

$$x = 6$$

Therefore, if the number of hours of work per day is reduced to 6 from 8 and the number of workers is increased to 24 from 12 then the time taken to complete the wall will be 6 days.

Example-15. The electricity bill is Rs.40 if 200 CFL bulbs are lighted for 6 days for four hours each day. How many CFL bulbs can be lighted for three hours every day for 15 days so that the electricity bill is Rs.48?

Solution: Suppose x bulbs can be lighted for three hours every day for 15 days so that the electricity bill is Rs.48.

In the first case,

We are given that one bulb is lighted for four hours every day for six days

Total time that one bulb is on = $6 \times 4 = 24$ hours.

Then, total time that 200 bulbs are on = 24×200 hours.

Similarly, in the second case,

We are given that x bulbs are lighted for three hours every day for 15 days

$$x \times 15 \times 3 = 45x$$

Here as the time increases the electricity bill will also increase or we have a direct relation (proportion).

Total Time 200 bulbs : Electricity bill :: Total Time x bulbs : Electricity bill
are lighted are lighted

$$200 \times 24 : 40 :: 45x : 48$$

$$\frac{200 \times 24}{40} = \frac{45x}{48}$$

$$x = \frac{200 \times 24 \times 48}{45 \times 40} = 128$$

Thus $x = 128$ CFL bulbs can be lighted for three hours every day for 15 days so that the electricity bill is Rs.48.

Example-16. 15 persons do a certain piece of work in 40 days. How many persons will be needed to complete one-fourth of the work in 15 days?

Solution: 15 persons complete 1 work in 40 days.

So, time taken by 15 persons to do $\frac{1}{4}$ work = $40 \times \frac{1}{4} = 10$ days.

Suppose, x persons do $\frac{1}{4}$ work in 15 days.

We know that number of persons and number of days are inversely proportional.

Number of persons number of days
 15 persons : x persons :: 15 days : 10 days

$$\frac{15}{x} = \frac{15}{10}$$

$$x = 10$$

Thus, 10 persons will complete $\frac{1}{4}$ work in 15 days.

Example-17. Two taps A and B can fill a tank in 30 minutes and 40 minutes respectively. A third tap C can empty the tank in 60 minutes. If all three taps are opened together, how long will it take the tank to fill up?

Solution: Since part filled by tap A in 30 minutes = 1

Therefore, part filled in 1 minute by tap A = $\frac{1}{30}$

Since part filled by tap B in 40 minutes = 1

Therefore, part filled in 1 minute by tap B = $\frac{1}{40}$

Since part emptied by tap C in 60 minutes = 1

Therefore, part emptied in 1 minute by tap C = $\frac{1}{60}$

If all three taps are opened together, then two will fill and one will empty the tank.

$$\begin{aligned} \text{Thus, part filled in 1 minute} &= \frac{1}{30} + \frac{1}{40} - \frac{1}{60} \\ &= \frac{4 + 3 - 2}{120} \\ &= \frac{5}{120} \end{aligned}$$

Since, time taken to fill $\frac{5}{120}$ parts is 1 minute

$$\begin{aligned} \text{Therefore, time taken to fill the entire tank} &= \frac{1}{\frac{5}{120}} \\ &= \frac{120}{5} \end{aligned}$$

24 minutes

Example-18. A pump fills a tank in 2 hours but due to a leak it takes 3 hours to fill it. If the tank is full how long will it take to empty due to the leak?

Solution: Part of tank filled by the pump in 2 hours = 1

Therefore, part of tank filled by the pump in 1 hour = $\frac{1}{2}$

Suppose part of tank emptied by the leak in x hours = 1

Then part of tank emptied by the leak in 1 hour = $\frac{1}{x}$

Since, even with the leak the tank gets full in 3 hours,

Therefore, part of tank filled by the pump in spite of the leak in 3 hours = 1

and, part of tank filled by the pump in spite of the leak in 1 hour = $\frac{1}{3}$

Part of tank filled by the pump in spite of the leak in 1 hour = [part of tank filled by the pump in 1 hour - part of tank emptied by the leak in 1 hour]

$$\frac{1}{3} = \frac{1}{2} - \frac{1}{x}$$

$$\frac{1}{3} = \frac{x-2}{2x}$$

$$2x = 3x - 6$$

$$x = 6$$

Therefore, in 6 hours the leak will cause the tank to become empty.

Try this



Three persons A, B and C can complete a task in 12, 15 and 10 days respectively. If they all work together, how long will they take to complete the task.



1. If the cost of 29 books is Rs.783 then how many books can be purchased in Rs.2214?
2. If $14 : 35 :: 16 : x$ then find the value of x ?
3. Find the fourth proportion in $2xy, x^2, y^2$
4. What should be added to 10, 18, 22, 38 so that they become proportional?
5. If b is the mean proportional of a and c then prove that

$$\frac{a^2 + b^2}{ab} = \frac{a + c}{b}$$

6. Find the numbers whose mean proportional is 24 and third proportional is 192.
7. Find x if $(1 + x) : (3 + x) : (6 + x)$
8. Two numbers are in the ratio 3:5. If 9 is subtracted from both the new ratio is 12:23. Find the first number.
9. A task is completed by 45 labourers in 24 days if they work 6 hours per day. How many labourers will be needed to complete the task in 15 days if they work for 8 hours every day?
10. A task is completed by 25 persons in 9 days if they work 6 hours per day. How many days will be needed to complete the task if 15 persons work for 9 hours every day?
11. A task is completed by 30 persons in 15 days if they work 6 hours per day. How many hours of work will be needed every day if 20 persons have to complete it in 15 days?
12. A car leaves Saraipalli, travels at 75 km per hour and reaches Raipur in 4 hours. The next time there was traffic and construction work on the road due to which the speed is decreased by 15 km per hour. How long will the car take to reach Raipur?
13. If 10 bulbs are lighted 4 hours every day for 60 days then the electricity bill is Rs. 80. How many bulbs can be lighted for 3 hours every day for 16 days so that the electricity bill is Rs. 40?
14. A task is completed by 48 persons in 25 days if they work 8 hours per day. How many days will be needed to complete double the task if 30 persons work for 10 hours every day?
15. A and B together complete a task in 24 days, C and B together complete the same task in 18 days, and A and C together complete the task in 12 days. How many days will A take to complete the task if he works alone?
16. A task is completed by 15 men in 16 days. How many men will be needed to complete $\frac{1}{4}$ th of the task in 15 days?
17. A camp has sufficient provisions for 120 soldiers. If after 40 days, 40 soldiers were deputed elsewhere, how long will the remaining provisions last for the remaining soldiers?
18. If 11 spiders spin 11 webs in 11 days then how many webs will one spider spin in one day?
19. Two taps together fill a tank in 6 hours. One of the taps alone fills it in 10 hours. How long will it take to fill the tank if only the second tap is open?



1. In our day to day lives we often have to compare quantities. Some sometimes the comparison is clearer if we take ratios. Therefore, we can better compare quantities by taking their ratios.
2. Whether we want to compare two players or want to buy something from the market, we can decide what is best only by comparing.
3. We can only compare two similar quantities that is, comparison is always between two quantities from the same category.
4. Sometimes we have to compare two ratios. Comparison of two ratios is called proportion.
5. Proportion helps us in dividing a quantity into two or more than two parts.
6. Often we see examples in our daily life when increasing or decreasing a quantity leads to decrease or increase of another quantity. These quantities are said to be in inverse proportion.

ANSWER KEY

Exercise-1

- | | | |
|------------------------|-----------------|-----------------------|
| 1. Dheerendra | 2. 11.4 km/hour | 3. 7:193, 3.5%, 96.5% |
| 4. $5\frac{1}{7}$ days | 5. One more | 6. 48 days |

Exercise-2

- | | |
|--|---------------|
| 1. 52,104,208 | 2. 23:33:60 |
| 3. ₹40,000, ₹20,000, ₹10,000, four times | 4. 53,106,265 |
| 5. 4 liter | |

Exercise-3

- | | | | | |
|-------------|--------------|-------------------|--------------------------|-----------------|
| 1. 82 | 2. 40 | 3. $\frac{xy}{2}$ | 4. 2 | 5. 12 & 48 |
| 7. 3 | 8. 27 | 9. 54 workers | 10. 10 days | 11. 9 hours/day |
| 12. 5 hours | 13. 25 bulbs | 14. 64 days | 15. $28\frac{4}{5}$ days | 16. 4 persons |
| 17. 30 days | 18. 11 days | 19. 15 hours | | |



COORDINATE GEOMETRY

CHAPTER

06

You must have seen a football ground, you might even have played in one. We know that before the game starts, the football is kept exactly in the middle of the ground. Players of both the teams stand facing each other, one on each side of the ground. Both sides of the ground have goal posts, as shown in figure-(i). The goal posts are at equal distance from the football kept at the centre of the ground.

The standard length of a football ground is 120 m and standard breadth is 90 m. Of course, we can play in a field of any size. Players of both teams are assigned different roles and they stand on the ground in their respective positions at the beginning, but they can go anywhere on the field during the match. In figure-(ii), we see the initial positions of the players of Team “A” on left side and Team “B” on right side.

The football is exactly at the central point of the ground. A line which separates both the teams is drawn in the middle of the field. If a line is drawn perpendicular to this line then the ground will be divided into four parts. Figure-(iii) shows this situation. In the figure of the field, on left side there are players of team “A” and on the right side there are players of team “B”. In the figure, on the left side the initial positions of the players of team “A” are represented by $a_1, a_2, a_3, \dots, a_{11}$ and on right side, initial positions of team B are represented by $b_1, b_2, b_3, \dots, b_{11}$.

You can see that both the goalkeepers stand at their respective ends of the field, near the goalposts. After that we have the fullbacks who stand 20-25 m further ahead from the goal post and then 40-45 meters further ahead we have the mid-fielders. Somewhere near the mid line the forwards of both teams stand in their respective positions and sides.

We will consider the left side where team “A” stands as negative direction and right side where team “B” is present as the positive direction. To indicate their positions we will use their distances from the lines which are passing through the mid-point of the ground.

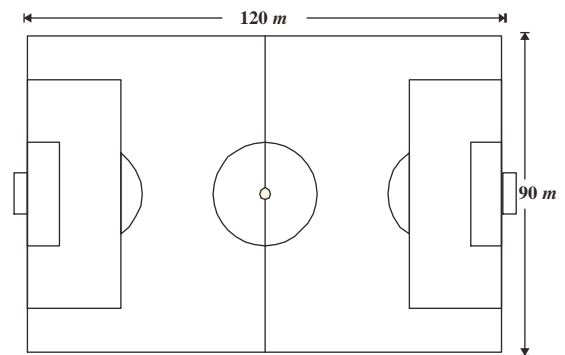

Figure - (i)

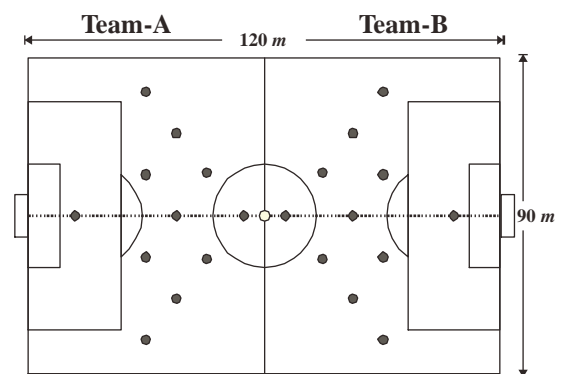

Figure - (ii)

Both goalkeepers stand $55m$ away from the midpoint on the horizontal line and hence we indicate them by $(55, 0)$ and $(-55, 0)$. Similarly, the fullbacks of teams “A” and “B” stand above the horizontal line, at a distance of -35 and of $+35$ respectively from the midpoint (central line). Team A has 3 fullbacks and team B has 4 fullbacks. These are either above the horizontal midline and are considered (+) or below the midline and considered (-).

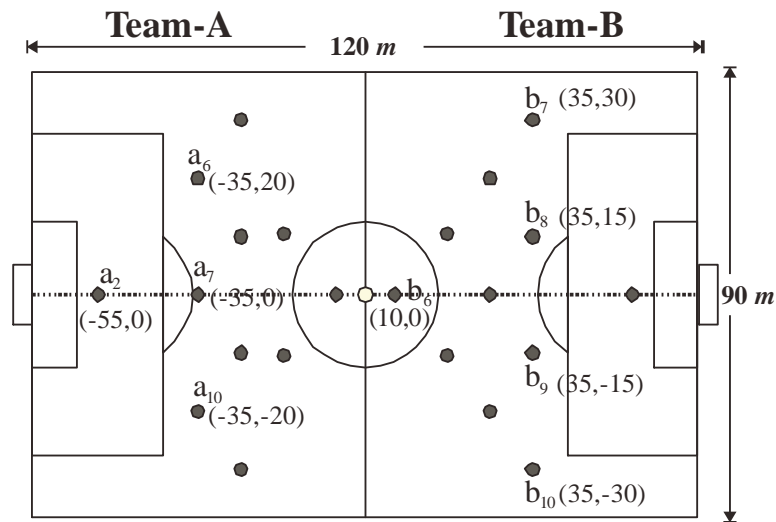

Figure - (iii)

Thus, the three fullbacks of team A are at $(-35, 20)$, $(-35, 0)$ and $(-35, -20)$ and the fullbacks of team B are at $(+35, 30)$, $(+35, +15)$, $(+35, -15)$ and $(+35, -30)$.



Think and discuss

Now, discuss with your friends and try to find the positions of other players on the field and indicate them using points.

Try These



1. Consider the net of a volley ball court as mid axis (line) and draw a perpendicular line exactly from its midpoint. Find the position of the all the players using these lines.
2. On the cricket ground, locate the positions of the batsmen and draw a line through them. Draw a perpendicular line from the midpoint of the line and locate the other players through this point.

Consider one more example where we try to find the position of the objects placed on the surface of a plane. You might have visited a cinema hall in your city or town to watch a movie. Do you remember how do you located your seat? In some cinema halls, rows of chairs are marked A,B,C, etc. and the numbers 1,2,3, are given to each chair in every row.

In this way, all the chairs are have a certain label like A_1 , A_2 , B_4 , C_{19} , D_{40} etc.

Consider a big meeting hall where several chairs are placed vertically and horizontally. You sit on the chair which is exactly in the middle of the meeting room. You know where your friends are supposed to sit.

How will you tell them where to sit?

Suppose there is a horizontal line under your chair passing from left edge to right edge of the meeting hall. This line divides the meeting hall into 2 parts, one part which is in your front and another part which is behind you. From this you can tell the position of the other chairs in the meeting hall, for example, chairs in your front, behind you and chairs on the horizontal line. Figure-(v)

If a similar line perpendicular to the first line passes under your chair from front to back of the meeting hall then this line also divides the hall into two halves, one on your right and other on your left side. So you have some new things to say about any chair, like the chair is on your right side, or the chair is on your left side or the chairs is on the line.

Now you see that the plane of the meeting room can be said to be divided into the 4 areas. Similarly, the chairs are also divided into 4 groups. Remember that some chairs are placed on the horizontal and vertical lines which separate the hall into 4 areas but are not included in these areas.

In prior classes, we have used the number line. We will take the help of number line in this situation also. Imagine that the lines which are passing under your chair are number lines which are perpendicular to each other and also cut each other at the point where your chair is placed, that is, they cut exactly at the centre of the meeting hall. This is the point where both the number lines have their zeroes.

Screen in Cinema Hall

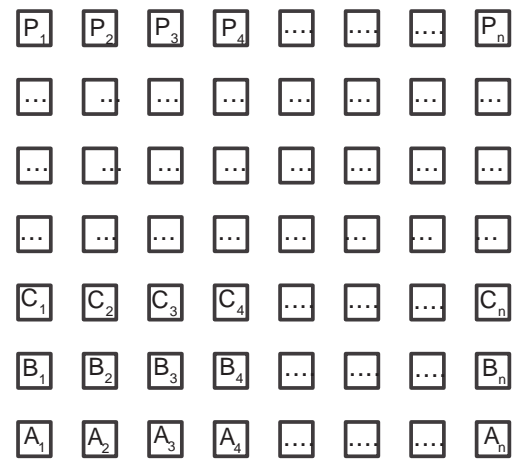

Figure - (iv)

Meeting Hall Dias

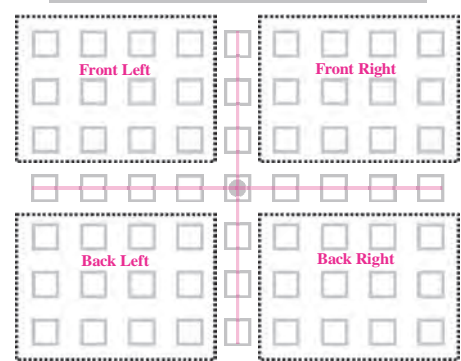

Figure - (v)

Meeting Hall Dias

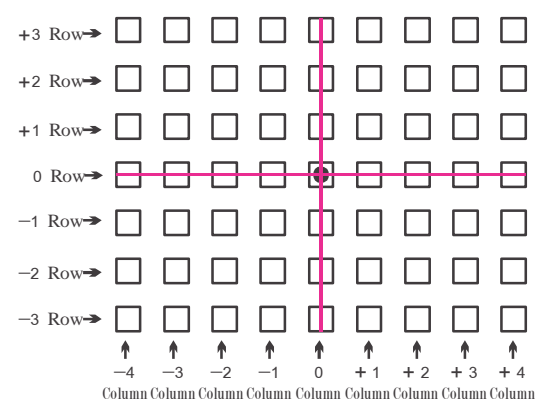

Figure - (vi)

So the chairs which are on the right side of the horizontal line are said to be +1, +2, +3 etc. and the chairs which are on the left side are said to be -1, -2, -3 etc. Similarly, we can say that the chairs which are in the front are +1, +2, +3 and those behind you are -1, -2, -3 respectively.

Can we also give names to the lines of chairs which are in the meeting room?

If we call the vertical lines of the chairs columns and the horizontal lines of chairs as rows, then you will be able to say that the vertical line which is passing under your chair is a column which passes through the zero of the horizontal line. All the columns on your right pass through +1, +2, +3 etc. of the horizontal line. We can call them +1 column, +2 column, +3 column. Similarly the column on the left side can be called -1, -2, -3 etc.

What will you call the vertical line which passes under your chair?

It is clear that you will call it zero column ("0" column).

Similarly, the horizontal line will be called zero row, the rows above it can be called +1 row, +2 row and the rows below it can be called -1 row, -2 row, -3 row.

Your friends A,B,C,D and E are standing near you in the middle of the hall and they want to reach their allotted seats. Their positions are given in figure-(vii). Let's tell them their positions.

Position of A - Chair is on column 2 and row 3

Position of B - Chair which is kept in column 2 and row -2

Position of C - Chair which is kept in column -3 and row -3

Position of D - Chair which is kept in column -4 and row 0

Position of E - Chair which is kept in column 0 and row 2

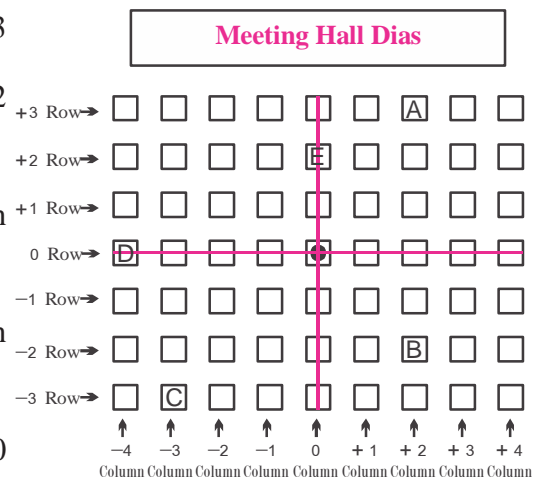

Figure - (vii)



Think and discuss

What is the position of your chair?

Try these

In a garden, plants are growing in vertical and horizontal lines. They are represented in rows and columns. If L, M, O, P represent lemon, mango, orange or papaya plants then locate their positions in terms of rows and columns.



Plants	Rows or Columns
Lemon	(+1 column, +3 row)
Mango,
Orange,
Papaya,

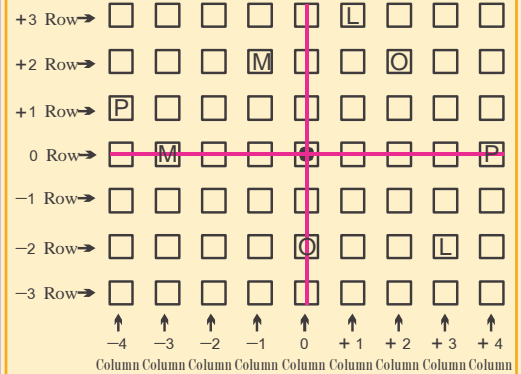

Complete the following table by seeing figure (iii) depicting a football ground.

Player	Distance of Football from Player		Position of the Player
	How many steps did you move to your left/right	How many steps you did you move up or down	
a_2			
a_6			
a_7			
a_{10}			
b_6			
b_7			
b_8			
b_9			
b_{10}			

In the above examples, we saw that the position of an object can be shown with the help of 2 mutually perpendicular lines. This idea was helpful in the development of coordinate geometry as a significant branch of mathematics. In this chapter we will introduce to you some basic concepts of coordinate geometry.

During the early years of its development, a French Philosopher and mathematician Rene Descartes worked in this field. He found the solution to the problem of showing the position of a point on a plane. His method was an offshoot of the ideas of Latitude and Longitude. The method which is used to determine the position of a point on a plane is also known as the Cartesian System in honor of Descartes.

Descartes proposed the idea of drawing two mutually perpendicular lines on a plane and finding the position of points on a plane with respect to these lines. The normal lines can be in any direction. In this chapter, we have used a horizontal line and a vertical line. The point where both the lines intersect each other is called the origin and it is denoted by O . Horizontal line $X'X$ is called the x -axis and the vertical line $Y'Y$ is called the y -axis. Because the values along OX and OY directions are positive hence OX and OY are called positive directions of x -axis and y -axis respectively. Similarly OX' and OY' are called the negative directions of x -axis and y -axis respectively.

Both the axes divide the plane into 4 equal parts. These 4 parts are called quadrants. These are named as I, II, III and IV quadrants respectively when we move in anti-clockwise direction from OX . Hence, this plane includes both the axis as well as all four quadrants. This plane is called Cartesian plane or coordinate plane or xy plane. The axes are called coordinate axes.

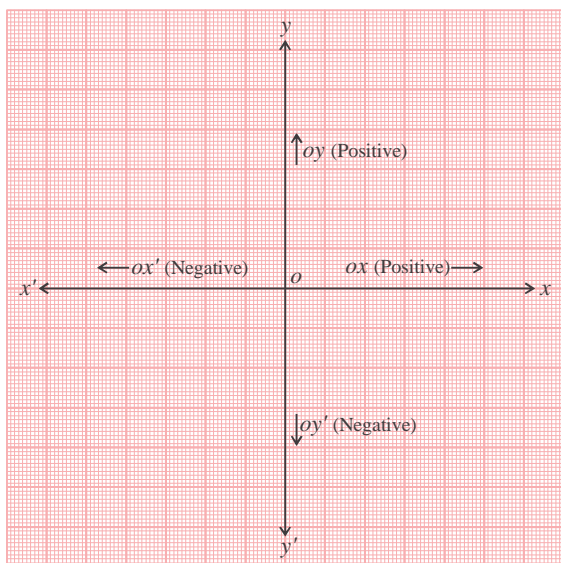

Graph-01

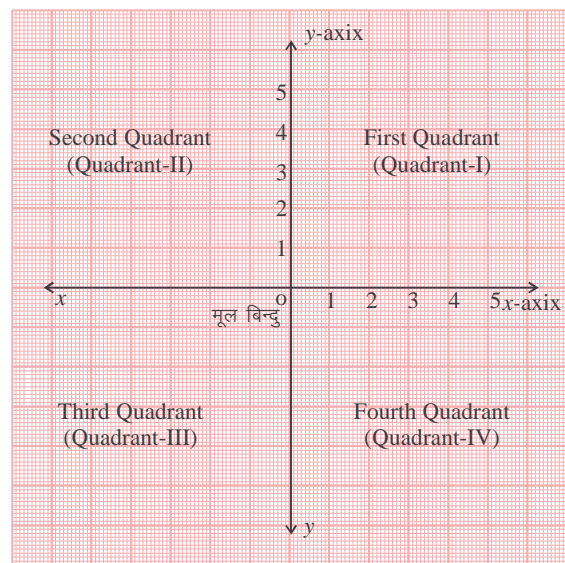

Graph-02

Finding the position of a point on the Cartesian plane

How do we find the position of a point on the Cartesian plane? Let us understand through an example.

Draw the x axis and y axis on a graph paper. Consider a point P anywhere in quadrant I. Draw perpendicular PM and PN from the point P to x axis and y axis respectively.

Here, the perpendicular distance PN of point p from the y axis is 4 units. (This is measured in the positive direction of x -axis) and the perpendicular distance PM of the point from x -axis is 3 units. (This can be measured in the positive direction of y -axis). With the help of these distances we can locate the point P . To locate the position of any point we have to remember the following conventions:

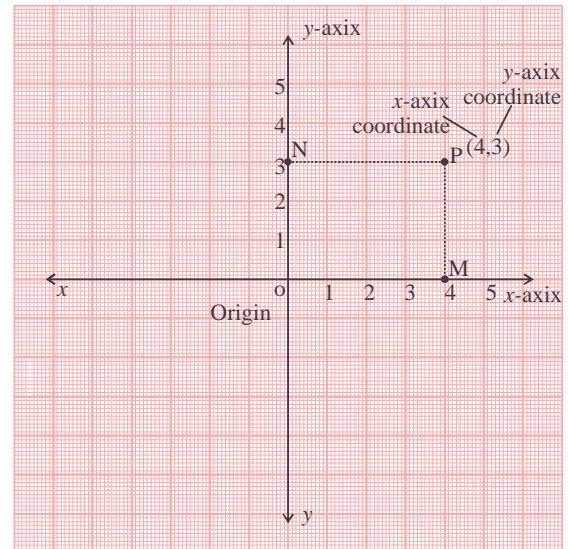

Graph - 03

1. The x -coordinate of any point is its perpendicular distance from the y -axis, and is measured on the x -axis. The distance is positive in the positive direction of x -axis and negative in the negative direction of x -axis. For point P it is $+4$. x -coordinate is called abscissa.
2. The y -coordinate of any point is the perpendicular distance from x -axis and is measured on the y -axis. This distance is positive in the positive direction of y -axis and negative in the negative direction of y -axis. For point P its value is $+3$. y -coordinate is called ordinate.
3. In Cartesian plane, while writing the coordinates of any point, we first write the x -coordinate and then the y -coordinate. The coordinates are written within brackets. Hence coordinates of point P are $(4,3)$.

Example-1. Locate point $A(4,5)$ on the Cartesian plane.

Solution : Because x -coordinate is $+4$, hence its perpendicular distance from y axis is $+4$ units. So we will move 4 units along the x axis in the positive direction. Because y -coordinate is $+5$, hence its perpendicular distance from x axis is $+5$ units. So we will move 5 units along the y axis in the positive direction. In this way, we will reach the point $A(4,5)$.

Example-2. Locate the point B $(-4,5)$

Solution : If x -coordinate of point B is -4 , then in which direction should we move?

Because the x -coordinate of point B is negative therefore we will move in OX^1 direction on the x - axis. Do the next steps yourself and locate the point B $(-4,5)$ on the Cartesian plane.

Try These



- Coordinates of some points are given below. In which quadrants do they lie? Locate each of them on the Cartesian plane-
 (i) $(5, 7)$ (ii) $(-2, 5)$ (iii) $(2, -2)$ (iv) $(-4, -5)$
- Write 5 more pairs of coordinates and locate them in the correct positions in the quadrants.

Points on the axis:

If any point lies on the x axis then what are the coordinates of that point? We know that to reach any point we have to cover two distances. First along the x axis (or perpendicular to y axis) and second, along the y -axis (perpendicular to the x -axis).

If any point is on the x - axis then we have to move only 1 distance from origin to that point. Because the distance moved parallel to y axis is zero, therefore the y -coordinate of that point is zero. Hence, the coordinates of any point on x -axis are $(x, 0)$ or $(-x, 0)$. For example, the coordinates of point A on X axis are $(4,0)$.

Similarly, the coordinates of any point on y - axis are $(0,y)$ or $(0,-y)$.

It is clear that the coordinates of origin are $(0,0)$.

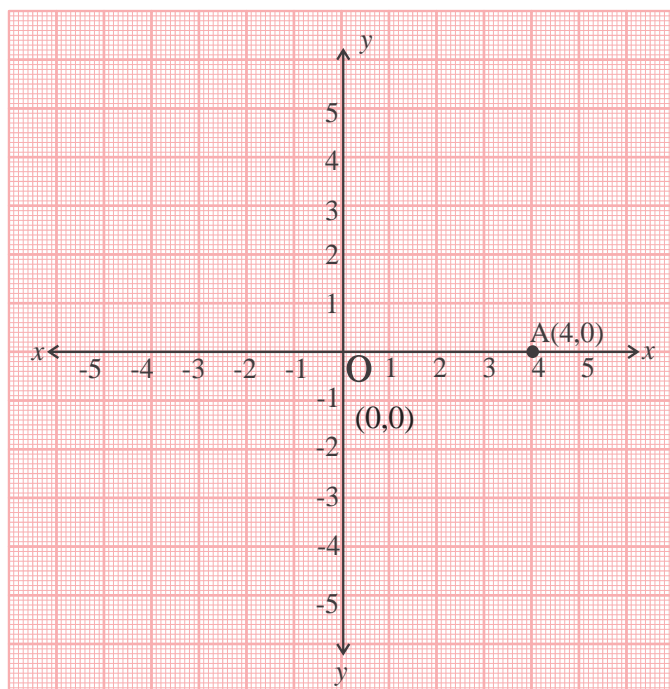

Graph - 04

Example-3. Locate the point P (3,0) on Cartesian Plane.

Solution : Because the y coordinate of the point P is zero, therefore the perpendicular distance of that point from x - axis is zero and hence this point is on the x -axis. X coordinate of point P is 3. Therefore this point lies at a distance of 3 units from the origin on the line OX.

Try These

1. Locate the points B (0, 4), C (0,0), and D (0, -2) and represent them on the Cartesian plane.
2. Write the coordinate of 3 different points which are on x -axis.
3. Similarly write the coordinates of 3 different points which are on y -axis.



Exercise - 1

1. Coordinates of some points are given below. Locate them on the Cartesian plane and write the quadrant in which the following points lie.
(i) (3,4) (ii) (-5,6) (iii) (-2,-1) (iv) (2.5, -7)
2. On the basis of the coordinates of the following points tell on which axis the points exist?
(i) (0,5) (ii) (-6,0) (iii) (-3,0) (iv) (0,-3.5)
3. Fill in the blanks:
 - (i) Point p (-4, -7) lies in quadrant.
 - (ii) The y - coordinate of any point on x axis is
 - (iii) On Cartesian plane both the axes are mutually
 - (iv) The x - coordinate of any point on y - axis is
 - (v) Coordinates of origin are



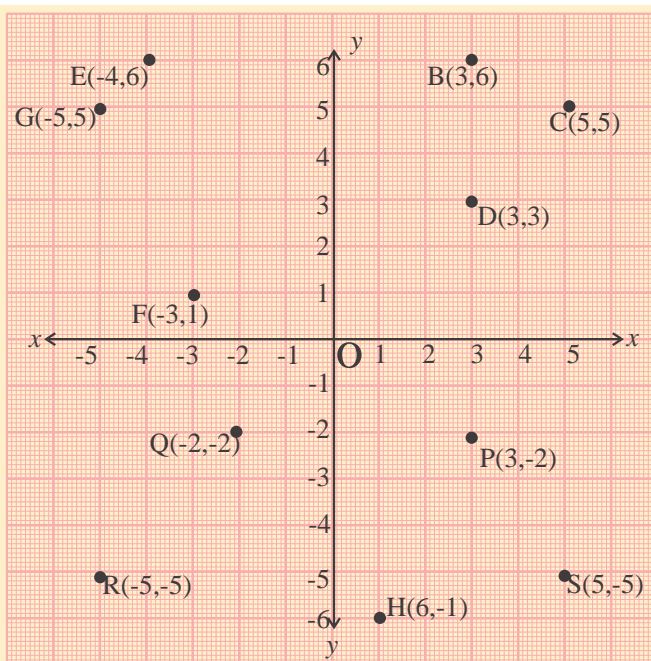

Graph - 05

4. Observe the position of given points in graph-5 and complete the task using the following instructions:

- (i) Write the points whose x coordinates are same.
- (ii) Write the points whose y - coordinates are same.
- (iii) Write the points whose x - and y - coordinates are same.

Distance between points

4 points A,B,C, and D are shown in the graph-6. Can you tell the distance between the points A,B and C,D ?

Is the distance AB between point A and point B less than the distance CD between point C and point D or are the distances equal?

How can we find the distance between 2 points whose coordinates are given?

It is easy to calculate the distance between 2 points which are located on horizontal or vertical axis or may be located on lines which are parallel to these axes. For example, A(1,1) and B(1,4) and similarly C(2,2) and D(6,2).

In the case of the first two points, just by taking the difference in y - coordinates we get the distance AB and in the second case by taking the difference in x - coordinates we get CD.

$$\text{Distance } AB = 4 - 1 = 3 \text{ units}$$

Since, $AB = y_2 - y_1$ (because x_2 and x_1 are equal)

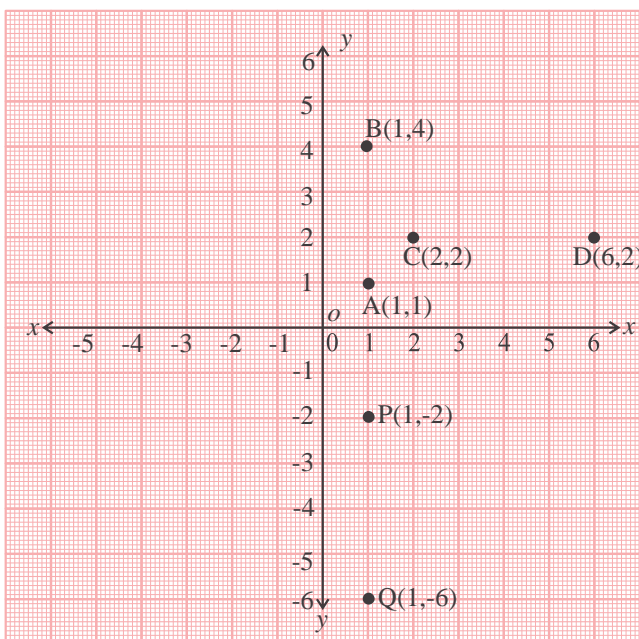

Graph - 06

Distance $CD = 6 - 2 = 4$ unit

Since, $CD = x_2 - x_1$ (because y_1 and y_2 are equal)

Similarly, the distance between $P(1, -2)$ and $Q(1, -6)$

$PQ = y_2 - y_1$ (because x_2 and x_1 are equal)

$PQ = -6 - (-2) = -4$

Because distance is always positive, hence $PQ = 4$ unit



Try These

Calculate the distance between the following pairs of points.

- (i) $(5, 8)$ and $(5, -3)$
- (ii) $(2, 3)$ and $(3, 7)$



Distance between any two points

In the previous examples we calculated the distances between any 2 points in which line segments AB , CD and PQ were either horizontal or vertical.

In case of two points which are neither on the horizontal/vertical axis nor on a parallel axis, how we can calculate the distances between them? Let us see one example.

Example:-4. Calculate the distance between the points $A(1, 2)$ and $B(4, 6)$.

Solution : From point A draw a line parallel to x -axis. Similarly from B , draw a line parallel to the y -axis. The two line intersect at point C .

Distance $AC = 4 - 1 = 3$ units.

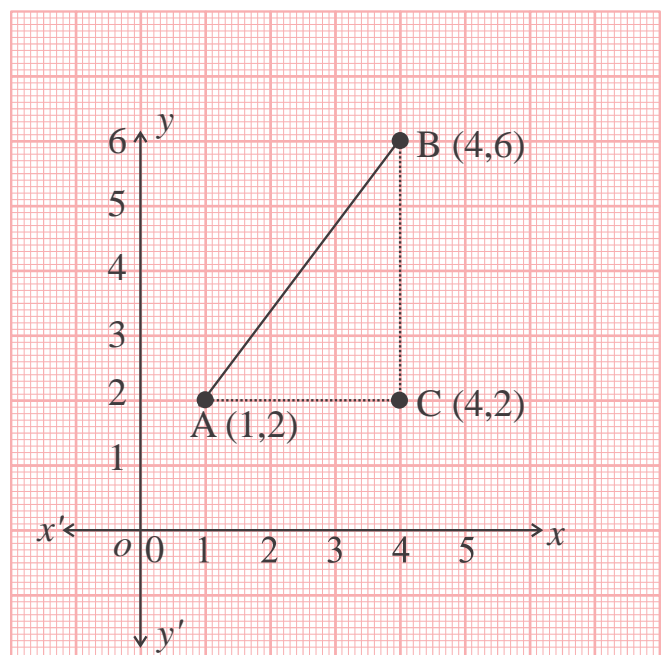

Graph - 07

and distance $BC = 6 - 2 = 4$ units

By using the Bodhayana sutra/Pythagoras theorem

$$\begin{aligned} AB^2 &= AC^2 + BC^2 \\ &= 3^2 + 4^2 \\ &= 9 + 16 \\ &= 25 \end{aligned}$$

Distance $AB = 5$ units

General Formula to calculate distances

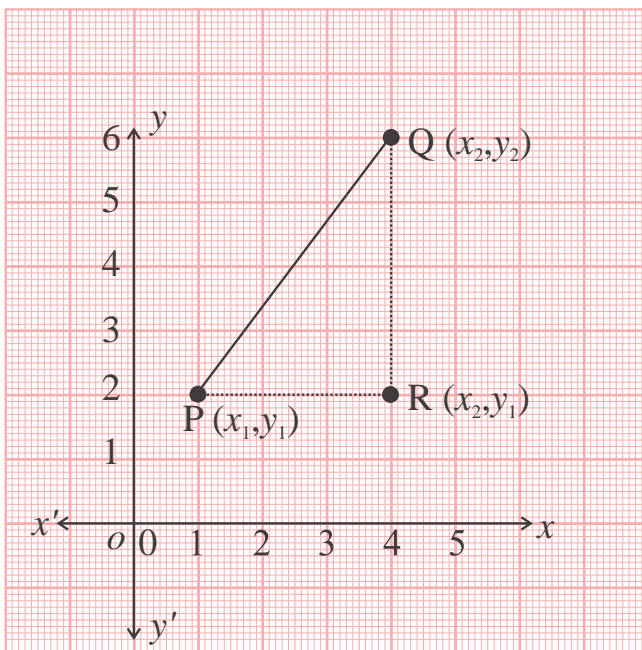

Graph - 08

To calculate the distance between any two points in a Cartesian plane, we need a method which is valid for all kinds of distances. We will calculate the distance between Q and P.

Consider the coordinates of the point p is (x_1, y_1) and Q is (x_2, y_2) .

In right angle triangle PRQ

$$\text{Distance } PR = x_2 - x_1$$

$$\text{Distance } QR = y_2 - y_1$$

In right angle triangle PRQ, using Pythagoras theorem

$$\begin{aligned} PQ^2 &= PR^2 + QR^2 \\ &= (x_2 - x_1)^2 + (y_2 - y_1)^2 \end{aligned}$$

$$\therefore PQ = \sqrt{(x_2 - x_1)^2 + (y_2 - y_1)^2}$$



Because $(x_1-x_2)^2$ and $(x_2-x_1)^2$ are equal, therefore, we can either calculate the distance from point “P” to point “Q” or from point “Q” to point “P”. In both the cases the result is same.

Hence, Distance PQ = Distance QP

This formula can be used to calculate the distance between any 2 points on the Cartesian Plane.

Example-5. Calculate the distance between points P (2,-3) and Q (5,-7).

Solution : Here, $x_1=2, y_1=-3, x_2=5, y_2=-7$

$$\begin{aligned} \therefore PQ &= \sqrt{(x_2-x_1)^2 + (y_2-y_1)^2} \\ &= \sqrt{(5-2)^2 + \{-7-(-3)\}^2} \\ &= \sqrt{3^2 + (-4)^2} \\ &= \sqrt{9+16} \\ &= \sqrt{25} \end{aligned}$$

$\therefore PQ = 5$ unit

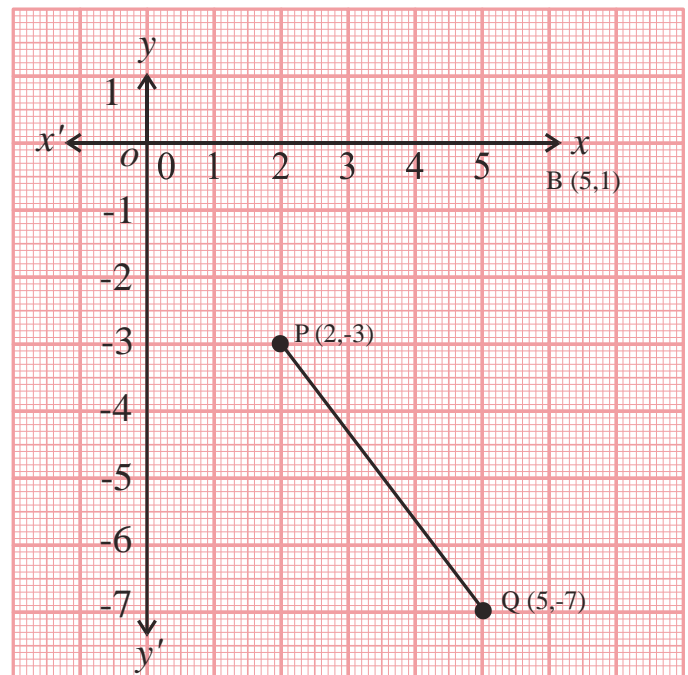

Graph - 09

Example-6. Find a point on y-axis which is equidistant from point A (6,5) and point B (-4, 3)

Solution : We know that any point which lies on the y- axis is in the form (0,y). Hence, consider the point P (0,y) which is equidistant from point A and point B then

$$PA = PB$$

$$(6-0)^2 + (5-y)^2 = (-4-0)^2 + (3-y)^2$$

$$36 + 25 + y^2 - 10y = 16 + 9 + y^2 - 6y$$



$$4y = 36$$

$$y = 9$$

The required point is (0,9).

Exercise - 2



1. Calculate the distance of point P from Q and R.
2. In graph-10, find the values of AC, AB and BC.

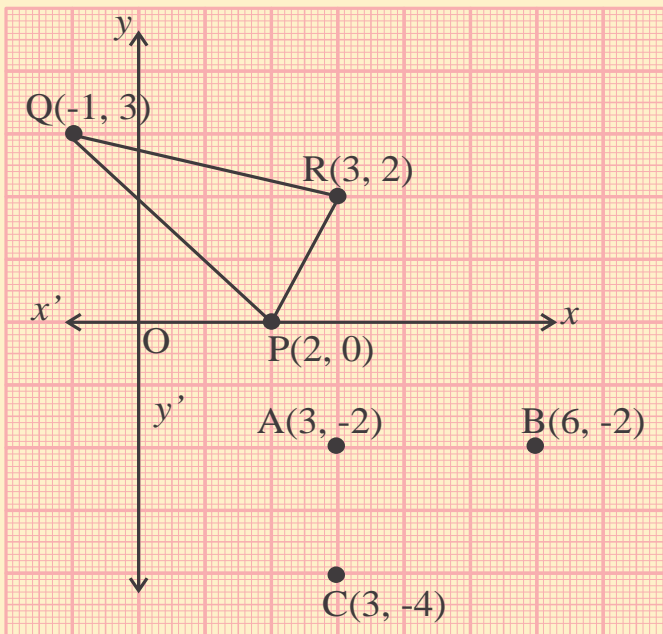

Graph - 10

3. Calculate the distance of point (3,4) from the origin.
4. If $PA=PB$ and the coordinates of point A and B are (2,0) and (-2, 4) respectively and if P lies on the y axis then calculate the coordinates of point P.
5. Find the coordinates of the point which is on y- axis and which is equidistant from points (5,-2) and (3,4).
6. Find the relation between x and y such that point (x,y) is equidistant from the point (7,1) and point (3,5).



Slope or gradient

Slope of the interval

Slope of the line or the gradient tells us about the steepness of slope or how rapidly the line ascends or descends. Therefore, the value of the slope of AB is the ratio of change in y -coordinates to the change in x -coordinate on moving from point B to point A. (Slope can also be called gradient).

If the coordinate of the point A is (1,2) and point B is (5,7).

then,

$$\begin{aligned} \text{Slope of line AB} &= \frac{y_2 - y_1}{x_2 - x_1} \\ &= \frac{7 - 2}{5 - 1} \\ &= \frac{5}{4} \end{aligned}$$

If we look carefully at this figure (Graph-11), we see a right angled triangle which is right angled at C. If we extend line segment AB then it will intersect the x -axis at some point P. The angle which this line makes with the x -axis is equal to the angle at point A in triangle ABC (Let this angle be θ).

$$\begin{aligned} \text{Slope of the line AB} &= \frac{y_2 - y_1}{x_2 - x_1} \\ &= \frac{AC}{BC} \\ &= \tan \theta \end{aligned}$$

$$\text{Slope} = \frac{AC}{BC} = \tan \theta$$

If we consider point B as first point and point A as second point then will the slope change?

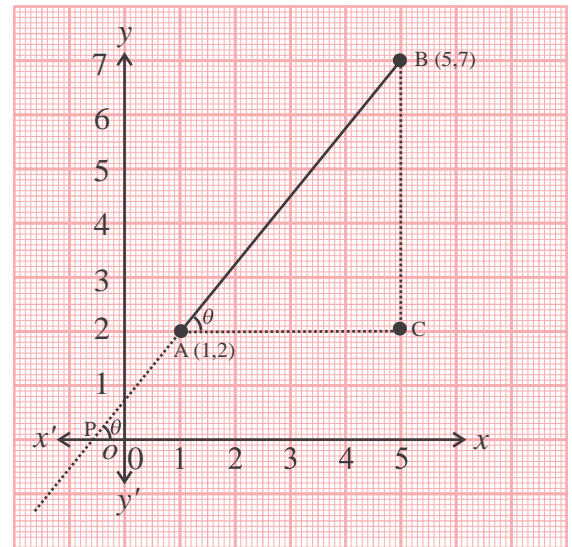

Graph - 11

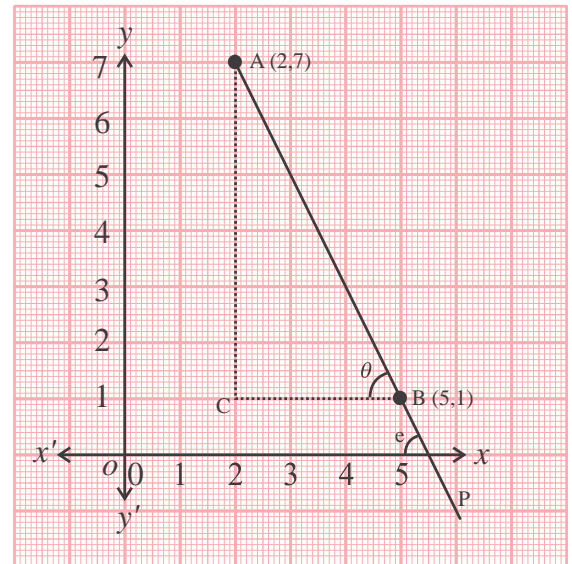

Graph - 12



$$\begin{aligned} \text{Slope} &= \frac{2-7}{1-5} \\ &= \frac{-5}{-4} \\ &= \frac{5}{4} \end{aligned}$$

It means that for given 2 points, on considering any point as first or second, the value of the slope of the line which passes through these points does not change.

Now, consider the slope of the interval AB which is shown in Graph 12.

$$\begin{aligned} \text{Slope of interval AB} &= \frac{(1-7)}{(5-2)} \\ &= \frac{-6}{3} \\ &= -2 \end{aligned}$$

That is, on moving from A to B in any interval, if value of y - decreases and value of x - increases then in such cases the slope of the interval is negative.

Special cases

1. When interval is horizontal : In such situations $y_2 - y_1$ is zero and therefore slope is zero.
2. When interval is perpendicular to x -axis : In such situations $x_2 - x_1$ is zero but since division by zero is not defined hence, we can say that slope is not defined.

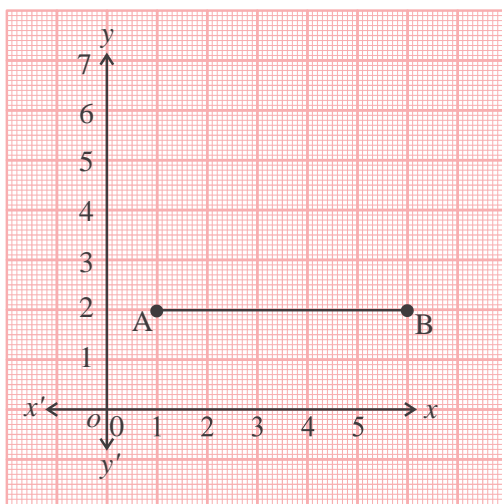

Graph - 13

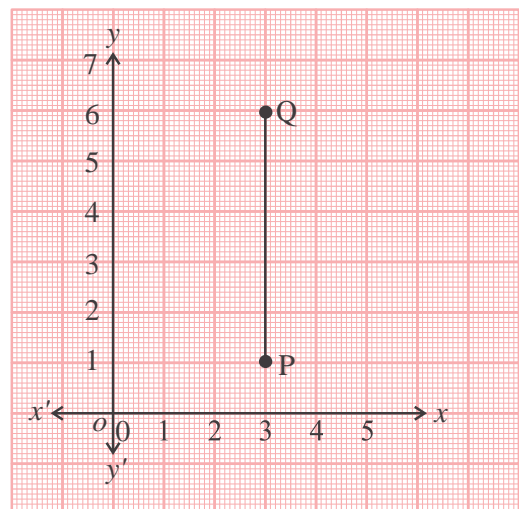

Graph - 14

Think and Discuss

See the graph-15. What can you say about the slope of the different lines? Discuss with your friends.

Which line segments have positive slope and which line segments have a negative slope.

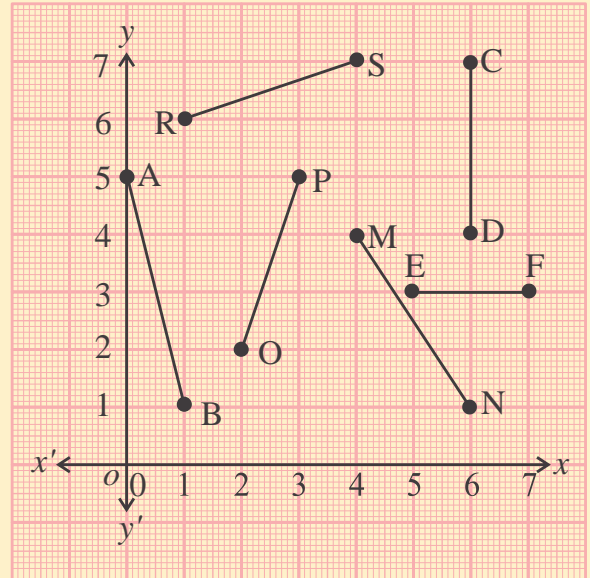

Graph - 15

Gradient of a line

The slope or gradient of a line is defined by the slope of any of its line segment because the slope of any two parts of a line will be same.

Consider that two intervals AB and PQ are on the same line. Construct right angle triangles ABC and PQR in which their sides AC and PR are parallel to the x - axis and BC and QR are parallel to y - axis.

In $\triangle ABC$ and $\triangle PQR$

AC is parallel to PR and slant line AQ intersects them.

Therefore $\angle A = \angle P$ (Corresponding angles)

Similarly, BC is parallel to QR and slant line AQ intersects them.

Therefore, $\angle B = \angle Q$ (Corresponding angles)

$\angle C = \angle R$ (Corresponding angles)

$\therefore \triangle ABC \sim \triangle PQR$

$$\therefore \frac{QR}{PR} = \frac{BC}{AC}$$

Now, we can say that slope of both the intervals (line segments) AB and PQ are equal.

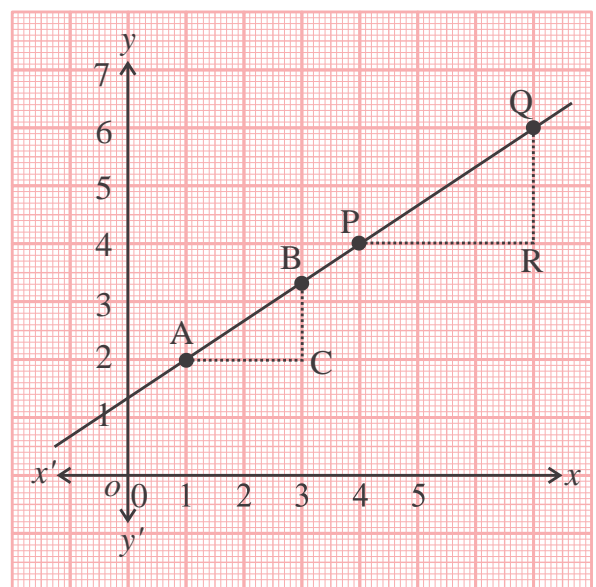

Graph - 16

Example-7. A line passes through the points (1,2) and (5,10). Find the slope.

Solution :

$$\begin{aligned} \text{Slope} &= \frac{y_2 - y_1}{x_2 - x_1} \\ &= \frac{10 - 2}{5 - 1} \\ &= \frac{8}{4} \\ &= 2 \end{aligned}$$

Example:-8. A line passes through a point (5,7) and its slope is $\frac{2}{3}$. Find the x coordinate of that point on this line whose y coordinate is 13.

Solution : First given point (5,7) is on the line. Coordinates of the second point will be (x,13)

$$\begin{aligned} \text{Slope of line} &= \frac{13 - 7}{x - 5} \\ &= \frac{6}{(x - 5)} \end{aligned}$$

$$\text{Therefore, } \frac{6}{(x - 5)} = \frac{2}{3} \quad (\text{Given})$$

$$18 = 2(x - 5)$$

$$18 = 2x - 10$$

$$x = 14$$



Comparison of Slopes (Gradient)

So far we have considered slope in reference of the coordinates of any 2 points on the line. Let us view it in a different context.

A cycle and horse cart (speeds 12 km/h and 16 km/h respectively) start moving together from the same place. The distances covered by them at different time intervals can be seen in the table given below:

Distance covered	In 15 minutes	In 30 minutes	In 60 minutes
By the horse cart	3 km	6 km	12 km
By cycle	4 km	8 km	16 km

Considering carefully the graph drawn, taking time and distance as coordinates.

In the graph, line OP represents the cycle and line OQ represents the horse cart. The intervals of these lines are AB and CD respectively.

$$\begin{aligned} \text{Slop of AB} &= \frac{16-8}{60-30} \\ &= \frac{8}{30} \\ &= \frac{4}{15} \end{aligned}$$

$$\begin{aligned} \text{Slop of CD} &= \frac{12-6}{60-30} \\ &= \frac{6}{30} \\ &= \frac{3}{15} \end{aligned}$$

It is clear that $\frac{4}{15} > \frac{3}{15}$

That is, slope of AB is more than slope of CD.

Now see the slope of AB in right angle triangle AMB.

$$\begin{aligned} \text{Slop of AB} &= \frac{16-8}{60-30} \\ &= \frac{BM}{AM} \\ &= \tan \theta_1 \end{aligned}$$

(Since $\angle BAM = \angle BOX$, θ_1 is the angle made by the line OP on x -axis).

Similarly the slope of CD = $\tan \theta_2$ (θ_2 = angle made by the line OQ on the x axis)

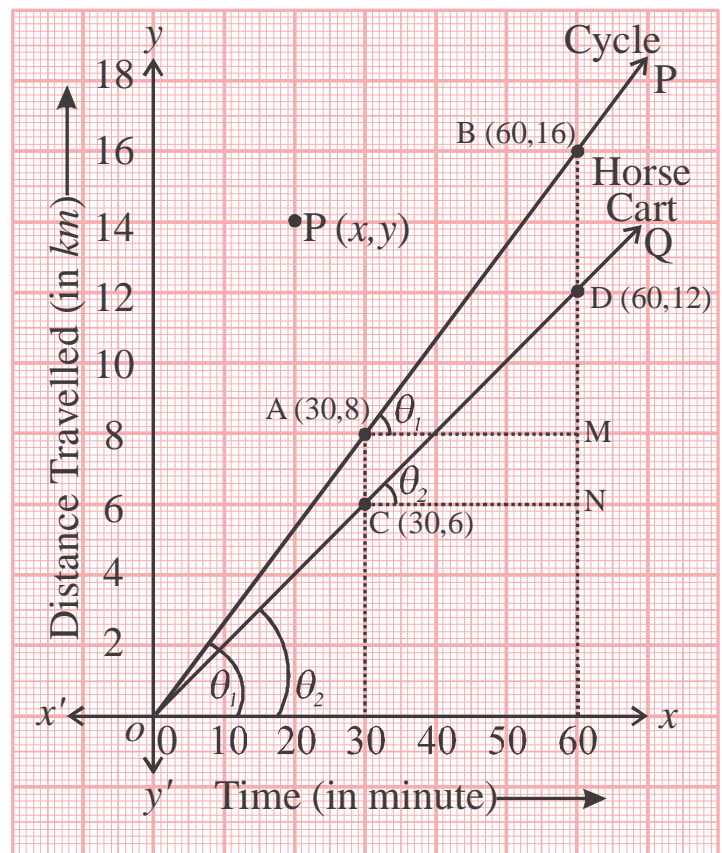

Graph - 17

We have seen that the tangent of the angle which is made by any line on the x -axis is also the slope of that line. It is clear that by increasing the angle, the slope also increases. One more thing observed here is that in triangle AMB, AM represents the time interval of 30 minutes and BM represents the distance covered in 30 minutes which is 8 km. Ratio between BM and AM represents the speed of the cycle. We find that speed of cycle is expressed by the slope of the line.

Intercept

The point at which a line cuts the x -axis, the distance of that point from the origin is called x -intercept. Similarly, the point at which the line cuts the y -axis the distance of that point from the origin is called the y -intercept.

Equation of line

Consider the equation $y=2x+4$. Can you find a pair of coordinates which satisfies this equation? For example,

For $x=0$

$$y = 2 \times 0 + 4$$

$$y = 4$$

Therefore (0,4) is a pair of coordinates which satisfies. Similarly, find other pairs of coordinates that satisfy the given equation. Now plot these points. Which kind of line did you draw? Is it a straight line?

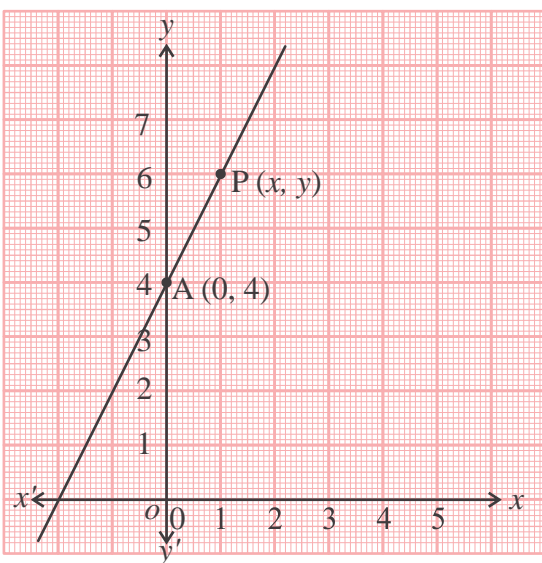

Graph - 18

Now considered a line where the y intercept is 4 and whose slope is 2. This line will pass through point A (0,4).

Consider any point P (x,y) on this line.

$$\begin{aligned} \text{Slope of interval AP} &= \frac{(y-4)}{(x-0)} \\ &= \frac{(y-4)}{x} \end{aligned}$$

Given that the slope of the line is 2.

$$\text{Hence, } \frac{(y-4)}{x} = 2$$

$$y = 2x + 4$$

This is the equation of that line which passes through the point (0,4) and the slope of which is 2. Because point P is also lies on this line therefore the coordinates of the point P also satisfy the equation.

Now, let us think of a line the slope of which is m and its intercept at y-axis is c. What is the equation of this line? This line passes through the point A (0,c). Consider the point P (x,y) on this line.

$$\text{Slope of the interval AP} = \frac{(y - c)}{(x - 0)} \dots\dots\dots(1)$$

$$\text{But we know that the slope of this line is "m"} \dots\dots\dots(2)$$

From (1) and (2)

$$\frac{(y - c)}{(x - 0)} = m$$

$$y - c = mx$$

$$y = mx + c$$



It means that $y=mx+c$ is the equation of that line on the Cartesian plane whose slope is m and which intercepts the y-axis at c.

Conversely, all those points whose coordinates satisfy the equation $y=mx+c$ are always lie on the line, whose slope is m and intercepts on the y axis is c.

Example-9. Write the slope of line and its intercepts on y-axis for the following.

(1) $y = 7x - 5$

(2) $y = -x + 5$

Solution :

(1) On comparing the equation $y=7x-5$ with the general equation $y=mx+c$, we get $m=7$ and $c=-5$. Therefore, slope of line is 7 and its intercept on the y-axis is -5.

(2) On comparing $y=-x+5$ with the general equation $y=mx+c$, we get $m=-1$ and $c=5$. Therefore, slope of line $m=-1$ and its intercept on y-axis is 5.

Exercise - 3

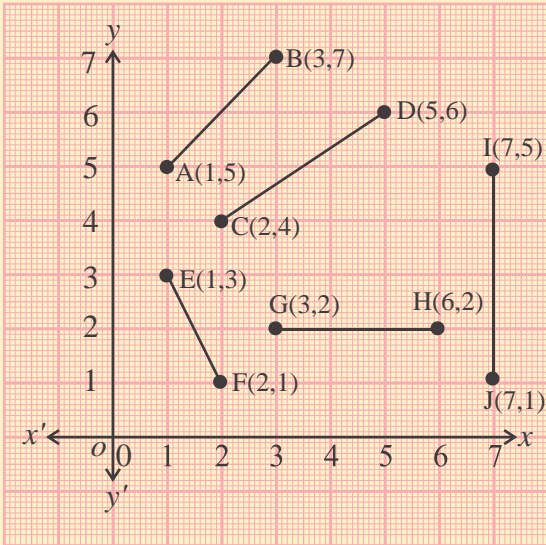

Graph - 19



- In the given graph-19, find the slope or gradient of the interval.
 - What is the slope of a line which is parallel to x -axis?
 - One line whose slope is $\frac{5}{6}$ passes through the point $(7,10)$.
 - Find the x -coordinate of that point whose y -coordinate is 15.
 - What will be the value of x -coordinate on y -coordinate -3?
 - A line passes through the point $(3,7)$ and $(6,8)$ then find the slope of the line.
- Write straight line $5x+6y=7$ in the form $y=mx+c$ and find the slope of line and its intercept from y -axis.
 - Find the equation of that straight line which cuts an intercept of 3 units on y - axis and whose slope is $\frac{5}{4}$.
 - What is slope of a line parallel to y axis?
 - Find the equation of that line which cuts the intercept of 6 units from y axis and whose slope is $-\frac{5}{3}$.
 - Find the slope of the line which passes through point $(6,0)$ and whose slope is $\frac{7}{3}$.
 - Find the slope of the line which passes through origin and also passes through point $(2,3)$.

What We Have Learnt

1. If, in any plane two mutually perpendicular lines XOX^1 and YOY^1 intersect at point O then XOX^1 is called the x -axis and YOY^1 is called the y axis and the point of intersection, O is called the origin and this plane is known as Cartesian plane.



2. In a Cartesian plane, x -coordinate of a point is equal to its perpendicular distance from y axis and y -coordinate is equal to perpendicular distance from x -axis.

3. In a Cartesian plane the distance between any 2 points $P(x_1, y_1)$ and $Q(x_2, y_2)$ is

$$PQ = \sqrt{(x_2 - x_1)^2 + (y_2 - y_1)^2}$$

4. In a plane the slope of the line or gradient is $\frac{y_2 - y_1}{x_2 - x_1}$, where the value of change in x coordinate from the point A to the point B is $x_2 - x_1$ and the value of change in y coordinate is $y_2 - y_1$.

5. The line of the equation whose slope is m and intercept at y -axis is c is $y = mx + c$.

ANSWER KEY

Exercise - 1

1. (i) First (ii) Second (iii) Third (iv) Fourth
2. (i) y -axis (ii) x -axis (iii) x -axis (iv) y -axis
3. (i) Third (ii) Zero (iii) Perpendicular (iv) Zero
(v) (0,0)
4. (a) B, D, P ; and G, R and C, S (b) B, E ; P, Q, C, G
(c) Q, R, D, C

Exercise - 2

1. $PQ = 3\sqrt{2}$, $PR = \sqrt{5}$
2. $AC = 2, AB = 3, BC = \sqrt{13}$
3. 5
4. $P(0,2)$
5. $\left(0, -\frac{1}{3}\right)$
6. $x - y - 2 = 0$

Exercise - 3

1. Slope of $AB = 1$, Slope of $CD = \frac{2}{3}$, Slope of $EF = -2$,
Slope of $GH = 0$, Slope of $IJ = \text{undefined}$
2. Zero
3. (i) $x = 13$ (ii) $x = -\frac{43}{5}$
4. $\frac{1}{3}$
5. $y = -\frac{5}{6}x + \frac{7}{6}$, Slope $= -\frac{5}{6}$, Intercept $= \frac{7}{6}$
6. $5x - 4y + 12 = 0$
7. undefined
8. $5x + 3y - 18 = 0$
9. $7x - 3y - 42 = 0$
10. $\frac{3}{2}$



Introduction

In mathematics we use different types of representations, including visuals, to better understand and analyze information. Graphs are one such visual representation and graphs help us define relationship between two quantities. If we have two mutually dependent quantities then we can also use graphs to tell how change in one quantity will lead to change in the second quantity. In addition, drawing graphs can also help in obtaining new information. In this chapter, we will look at different applications of graphs.

Relationship between two quantities

Some people buy 1 meter, 2 meter, 3 meter, 4 meter and 5 meter cloth, at Rs.25 per meter, paying Rs.25, Rs.50, Rs.75, Rs.100 and Rs.125 respectively. The relation between the money spent by them and the length of cloth bought is shown in the graph. From the graph we are able to see how the money spent changes with increase in length of cloth purchased.

Let us see another example.

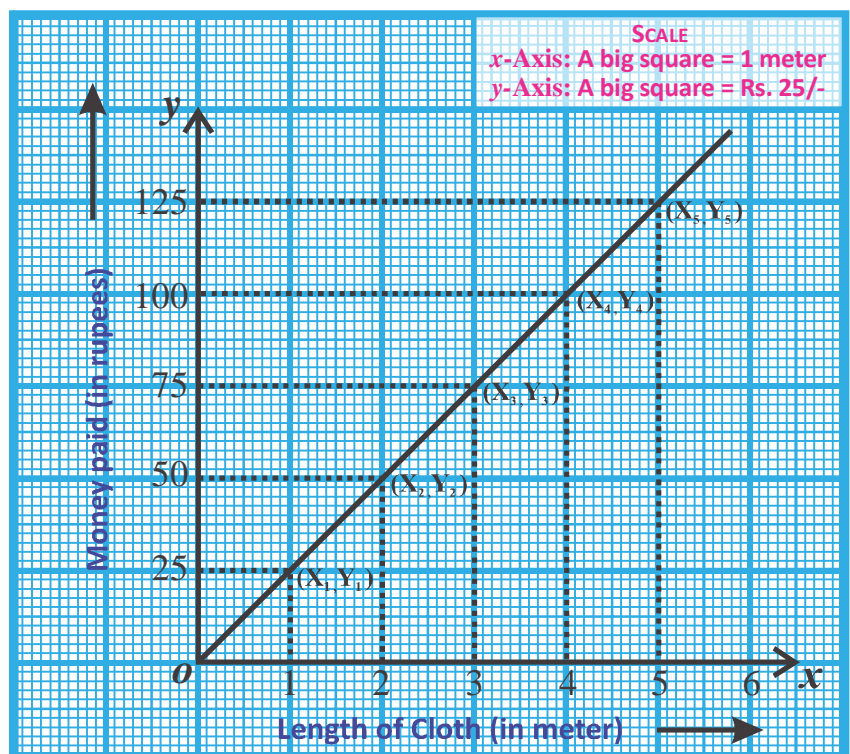

Graph - 01

The runs scored by a cricket team in the initial ten overs are as follows – 5, 4, 8, 7, 2, 5, 4, 4, 2 and 9. If we take the over number and the runs scored in that over to draw a graph, then we will get the curve shown in figure-2.

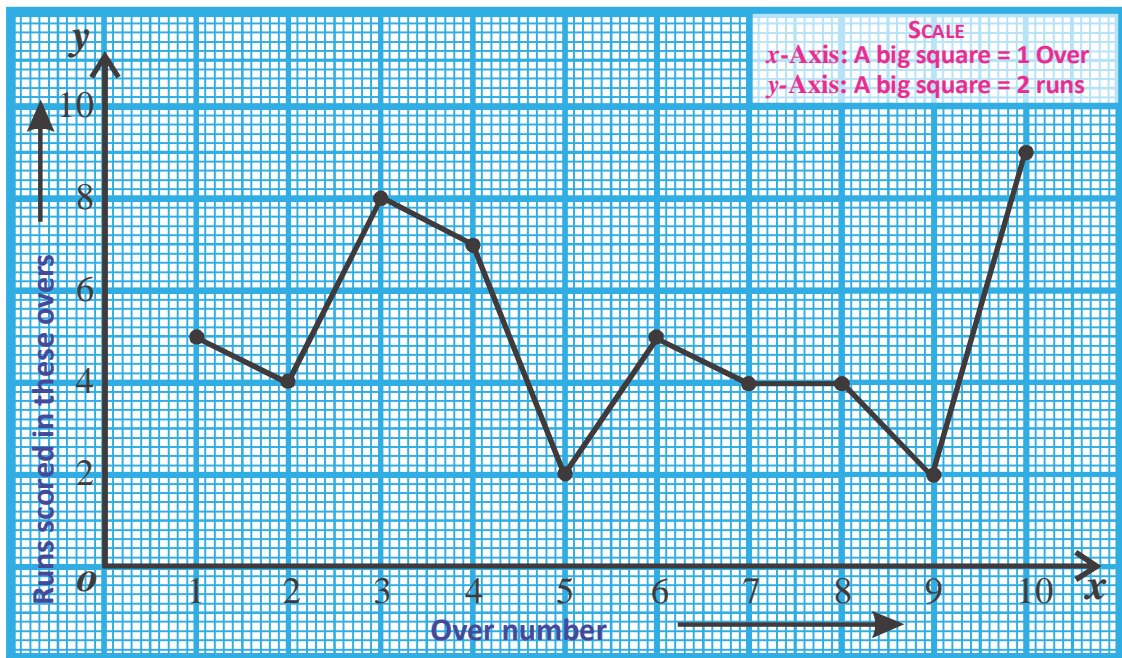

Graph - 02

Think and Discuss



1. In each of the situations described above, is there any relation between the quantities taken to draw graphs?
2. One type of quantity was taken on the X-axis and the other on Y-axis. Is there any basis of choosing a particular axis for a particular quantity?
3. One graph is in the form of a straight line and the other is a zig-zag curve; what could be the reason for this difference?

Learning to draw graphs

We require two types of data to draw graphs. One type is depicted on the X-axis and the other on Y-axis. Can we take any axis to show these quantities? Or is there a basis for deciding which quantity should be shown on the X-axis and which on Y-axis?

If we look at the graph-1 we find that if we buy more cloth then we have to pay more money and if we buy less cloth then we spend less money. This is one example where one quantity directly affects the other quantity. The amount of money paid or

spent directly depends on the length of cloth purchased. So we can say that the length of cloth is an independent variable whereas the money spent is dependent variable. Usually, we take the independent variables (data points) on the X-axis and the dependent variables on the Y-axis.

Once we have determined which quantity to keep on the X-axis and which quantity should be taken on the Y-axis then we decide the scale.

Scale – To depict the chosen quantities on the X-axis and Y-axis, we need to choose a suitable scale according to the values of chosen quantities. Let us understand what this means using graph-1 as example. The payment made for 5 meter cloth is Rs. 125. If we decide that in our scale Rs. 1 = the length of one square, then our axis would be 125 squares long which is not possible on a sheet of paper. On the other hand, if we take Rs. 50 = length of one square, then our axis would become very condensed. So we have to choose a scale that clearly shows the relations. Here, we have taken length of one square = Rs. 25 and then drawn a 6 units long axis. While drawing graphs, the following points should be kept in mind for choosing a scale:

- The difference between the maximum and minimum values of each quantity
- Utilizing as much area as possible of the graph paper

Each point has to be shown on the graph. For a given value on the x-axis, we mark a point at a distance equal to the corresponding y value. Both the values determine the position of the point. We get the graph by joining all points.

What information do we get from graphs?

You must have seen different types of graphs in newspapers, magazines and on television. These graphs are visual representations of numerical data. They give us several pieces of information at a glance. Let us look at the two graphs discussed so far. When we plot the graph by taking the length of cloth and its cost on the two axis then the straight line obtained shows that there is a fixed ratio between the cost and length.

$$\left(\frac{100}{4}, \frac{75}{3}, \frac{25}{1} \dots \text{etc.} \right)$$

If we want to know how much cloth can be purchased for a given amount of money or what will be the cost of given length of cloth, we can find the answers easily from the graph.

The second zig-zag graph tells us that the number of runs scored in any over is not certain and we can't predict. But we can easily tell the overs in which maximum and minimum runs were scored by looking at the graph. The average runs scored can help us predict how many runs might be scored at the end of 20 or 50 overs. Of course, our prediction may be wrong because the entire team could get out or the rate of scoring could accelerate in the final overs.

Some more graphs

Graph 3:- The following table shows the number of students in the hostel of an upper primary school in Jamraon and the quantity of lentils cooked for them in any given week.

Number of the students	16	19	22	23	21	18	17
Quantity of lentils (in kg)	1.280	1.520	1.760	1.840	1.680	1.440	1.360

Number of students and quantity of lentils are the data points.

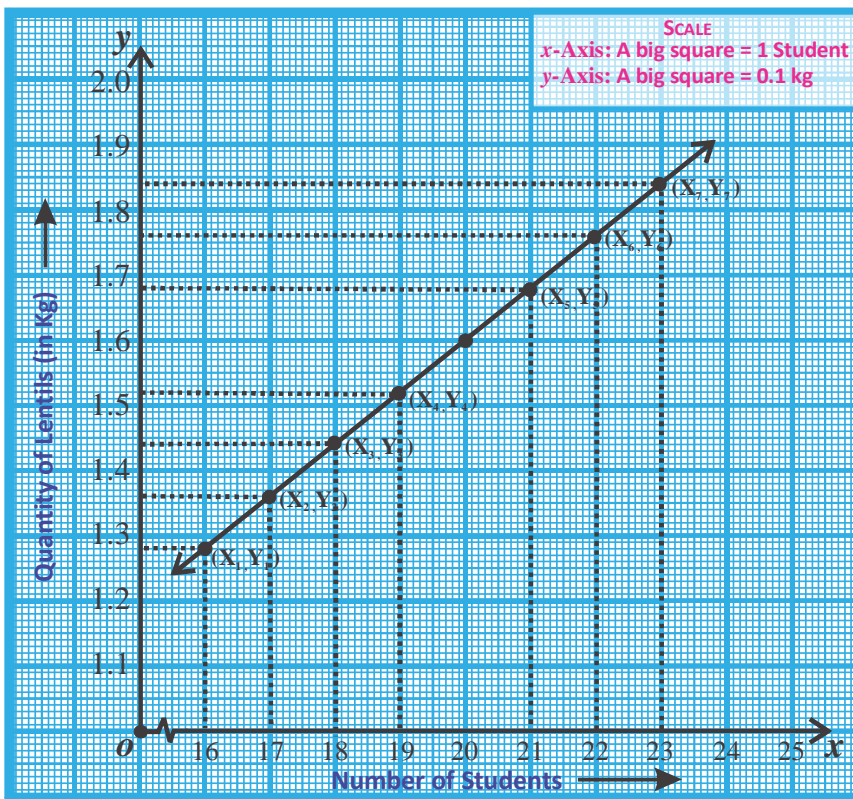

Graph - 03

Do you see any relation between the number of students and the quantity of lentils cooked for them? Let us understand by making a graph.

We can see that the quantity of lentils increases and decreases with increase or decrease in number of students. Is there a fixed rate for this change?

Discuss among yourselves. Notice that this graph does not start from 0,0. Often, we find situations where data points do not start from zero or near it. In such a situation we use \sim on the axis to denote the empty region of the graph. For example, in graph-

3 the readings on x-coordinate start from 16 and there are no data points between zero and sixteen so this portion is shown by a \sim .



Think and Discuss

If we plot a day-wise graph between number of students and quantity of lentils cooked, what will be the nature of the graph?

Graph-4. Phoolmanti purchased 4 kg rice for her home. 500 g rice is cooked each day in her house. Can we plot the graph for quantity of rice left each day?

Solution : Here the two datas are days and quantity of rice remaining on that day. The first data point is (1,3.5) and the fifth data point is (5, 1.5).

You can see that with increase in number of days, the quantity of rice remaining is decreasing. By looking at the graph can you tell when the rice would finish?

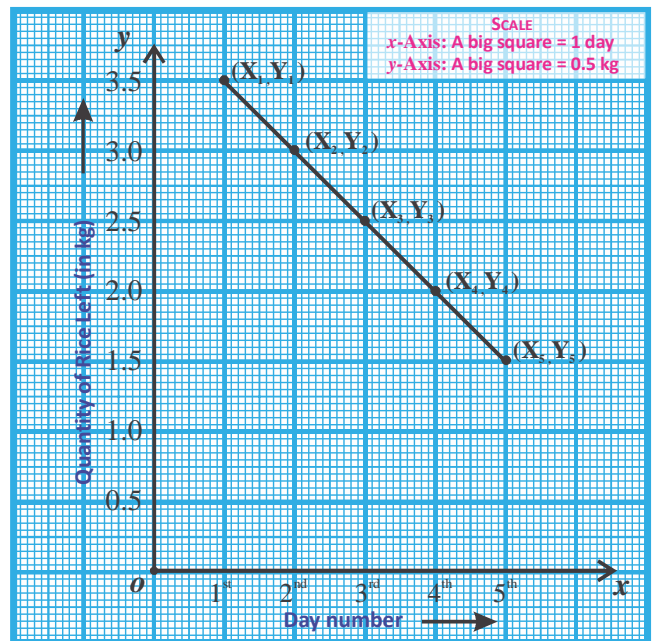

Graph - 04



Try this

1. Collect similar data from around you and plot graphs for this data.
2. Although both graphs 3 and 4 are straight lines yet they are different from each other. What are the differences in the two graphs?
3. Make (x,y) table for graphs 3 and 4.

Graph-5. The table below shows the lengths of one side of some squares and their respective perimeters.

Length of side of square (in cm)	1	2	3	4	5	6	7
Perimeter of square (in cm)	4	8	12	16	20	24	28

Draw a graph between the figures given in the table and answer the following questions –

1. Which data set did you choose for the x -axis?
2. Which data set did you choose for the y -axis?

Solution : In the graph we can see that increasing the length of any one side of a square leads to increase in perimeter. This means that in the given data-sets, the length of side of a square is an independent variable and perimeter is dependent variable. Therefore, we will take length of side of square on the x -axis and perimeter on the y -axis.

Graph-6. The lengths of sides of different squares and corresponding areas are shown in the table given below. Use them to draw a graph.

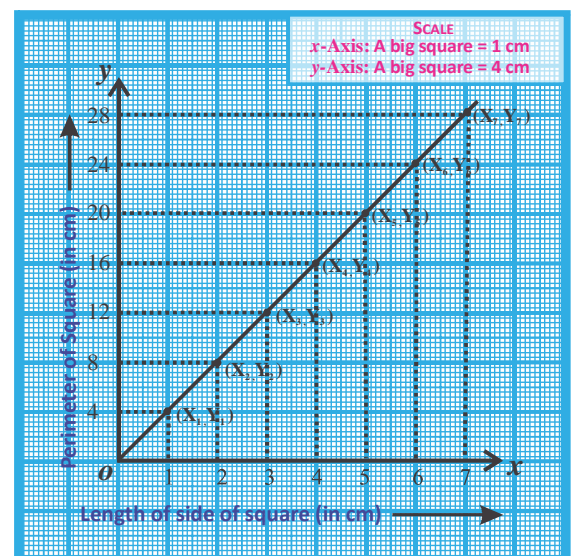

Graph - 05

Length of side of square (in cm)	0	1	2	3	4	5	6	7
Area of square (in cm square)	0	1	4	9	16	25	36	49

area we find that area increases with increase in length of side but we do not get a straight line. Instead we get an upward moving curve.

Think and Discuss

What differences can you see between graphs 5 and 6? Discuss.



Graph-7. The temperatures between 6 am and 6 pm, on any given day in the month of March are shown in the table given below.

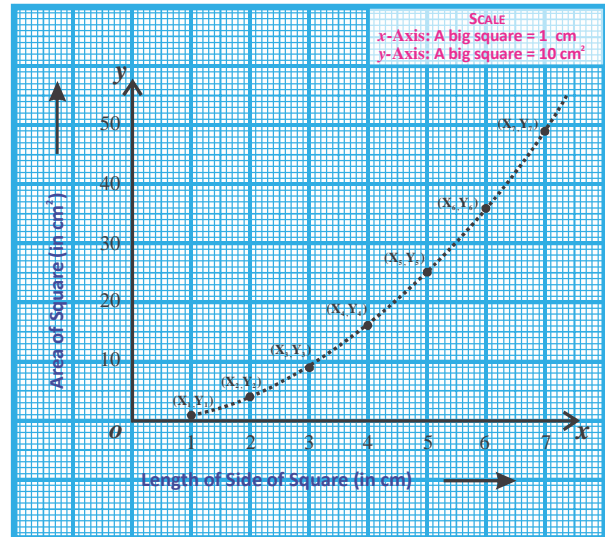

Graph - 06

Draw a graph based on these figures.

समय	पूर्वाह्न							अपराह्न					
बजे	6	7	8	9	10	11	12	1	2	3	4	5	6
ताप ($^{\circ}\text{C}$ पर)	23	25	27.5	29	31	33.5	35.5	37.5	38.5	39	37.5	34	30

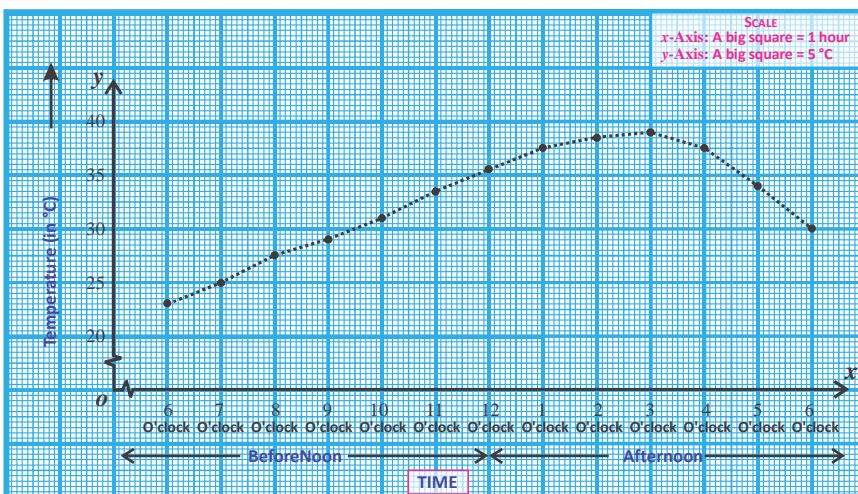

Graph - 07

Can you think why this is so?

Discuss with your friends.

Write five conclusions based on this graph.

Graph-8. Find the simple interest on Rs. 100 for 1, 2, 3 and 4 years at 10 percent annual interest rate. Draw the graph between time and

simple interest and see how the interest changes with time.

Also answer the following questions:

1. Which data set did you choose for the x-axis?
2. Which data set did you choose for the y-axis?
3. What scale did you choose for the x- and y-axis?

Solution : We have been given:-

Principal = Rs.100 and Interest = 10%

Keeping the principal and rate of interest constant and changing time period to 1,2,3 and 4 years, we can obtain the simple interest as shown in the table below:

Time (in years)	0	1	2	3	4
Simple Interest (in rupees)	0	10	20	30	40

$$\text{Simple Interest} = \frac{\text{Principal} \times \text{Rate} \times \text{Time}}{100}$$

From the graph, we can see that when rate and principal are constant then the simple interest changes at a constant rate with change in time period.

We have taken time (independent variable) on the x-axis and simple interest (dependent variable) on the y-axis.

Scale- On x-axis, 1 unit = 1 year
 On y-axis, 1 unit = Rs.10

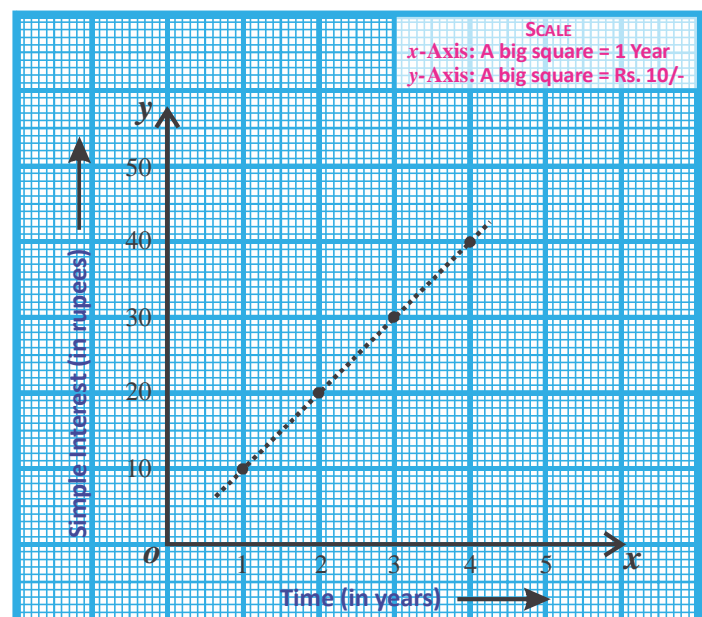

Graph - 08

Try This



1. Some persons were loaned Rs.100, Rs.200, Rs.300 and Rs.400 at 10 percent annual simple interest. Draw the graph for the interest obtained from each of them.
2. Make a table showing the age (in months) and height (in cm) of your classmates. Plot a graph between age and height. From this plot, can you see a definite relation between age and height?

In the graphs discussed so far, we sometimes got a curve and sometimes a straight line. Can you think why?

It is clear that the shape of the plotted graph depends on the relation between the quantities represented on it. This relation also decides the shape of the curve. We will now try to find the relation between different quantities.

In graph-1,

$$X_1 = 1, X_2 = 2, X_3 = 3, X_4 = 4, X_5 = 5$$

$$Y_1 = 25, Y_2 = 50, Y_3 = 75, Y_4 = 100, Y_5 = 125$$

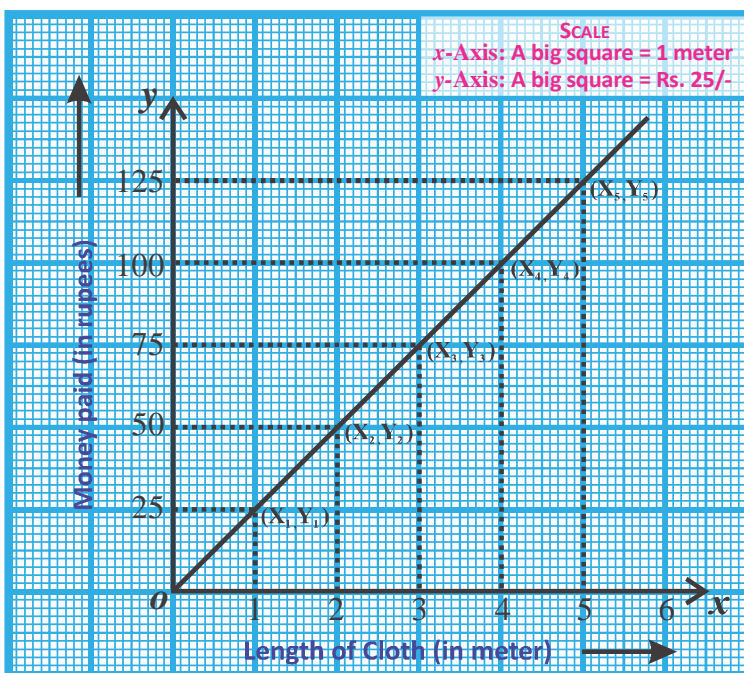

Graph - 01

$$\text{Here, } \frac{Y_2 - Y_1}{X_2 - X_1} = \frac{50 - 25}{2 - 1} = \frac{25}{1}$$

$$\frac{Y_3 - Y_2}{X_3 - X_2} = \frac{75 - 50}{3 - 2} = \frac{25}{1}$$

$$\frac{Y_5 - Y_4}{X_5 - X_4} = \frac{125 - 100}{5 - 4} = \frac{25}{1}$$

In graph 4,

$$\frac{Y_2 - Y_1}{X_2 - X_1} = \frac{3 - 3.5}{2 - 1} = -0.5$$

$$\frac{Y_3 - Y_2}{X_3 - X_2} = \frac{2.5 - 3.0}{3 - 2} = -0.5 \quad \dots \text{ etc.}$$

In graph 5,

$$\frac{Y_2 - Y_1}{X_2 - X_1} = \frac{8 - 4}{2 - 1} = 4$$

$$\frac{Y_3 - Y_2}{X_3 - X_1} = \frac{12 - 8}{3 - 2} = 4 \quad \dots \text{ etc.}$$

We can see that each of in graphs 1,4 and 5

$$\frac{Y_2 - Y_1}{X_2 - X_1} = \frac{Y_3 - Y_2}{X_3 - X_2} = \dots \text{ Is constant and}$$

the graph is a straight line.

This means that wherever,

$$\frac{Y_2 - Y_1}{X_2 - X_1} = \frac{Y_3 - Y_2}{X_3 - X_2} = \frac{Y_4 - Y_3}{X_4 - X_3} = \dots = \frac{Y_n - Y_{n-1}}{X_n - X_{n-1}} = \text{is a constant, the graph will be}$$

in the form of a straight line. In these types of plots the relation between quantities can be depicted by the linear equation $ax + by = c$ or $y = mx + c$.

Is there any such relation in the other graphs as well?

In graph-7 we find that-

$$\frac{Y_2 - Y_1}{X_2 - X_1} = \frac{25 - 23}{7 - 6} = \frac{2}{1}$$

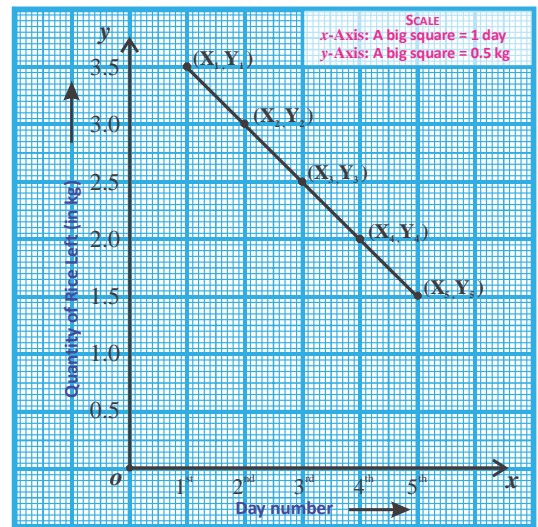

Graph - 04

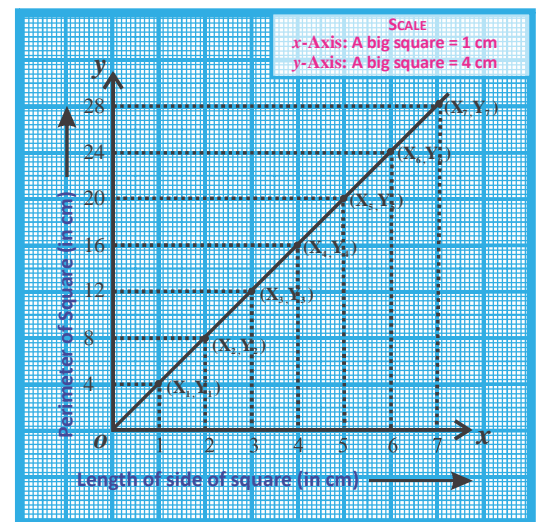

Graph - 05

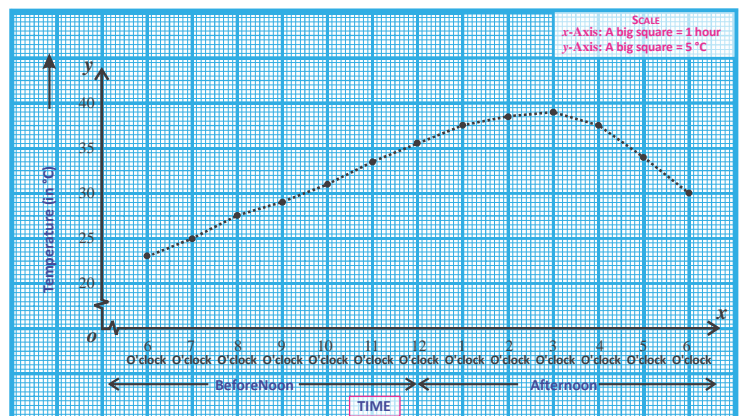

Graph - 07

$$\frac{Y_3 - Y_2}{X_3 - X_2} = \frac{27.5 - 25}{8 - 7} = \frac{2.5}{1}$$

$$\frac{Y_4 - Y_3}{X_4 - X_3} = \frac{29 - 27.5}{9 - 8} = \frac{1.5}{1}$$

----- etc.

Clearly,

$$\frac{Y_2 - Y_1}{X_2 - X_1} \neq \frac{Y_3 - Y_2}{X_3 - X_2} \neq \frac{Y_4 - Y_3}{X_4 - X_3} \dots\dots\dots$$

Similar relationship can also be observed in graph-6.

In these two examples,

$$\frac{Y_2 - Y_1}{X_2 - X_1}, \frac{Y_3 - Y_2}{X_3 - X_2}, \frac{Y_4 - Y_3}{X_4 - X_3} \dots\dots\dots \text{...are not constant.}$$

Therefore, the plots are not straight lines.



Try this

Note the height of the plants in and around your school for 10 weeks and plot the obtained observations. How did the height of plants change with time?

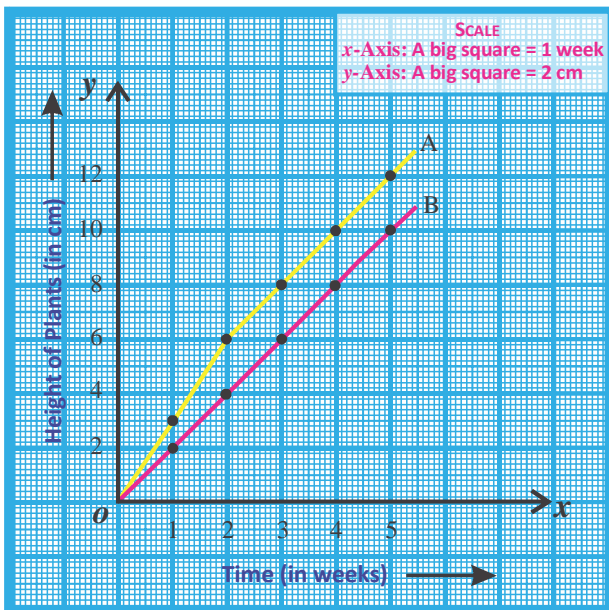

Graph - 09

Reading graphs describing different situations

Now we will learn how to read, understand and analyze graphs through various examples.

Example:-1. To different types of plants were potted in two pots A and B and their height was noted at the end of the week for 5 weeks. The measurements are shown in the graph. Use the graph to answer the following questions:

- (i) What was the height of each plant at the end of five weeks?
- (ii) In which did the plant in pot A grow most and what was the increase in its height in this week?
- (iii) What was the height of the plant in pot B at the end of week four?

Solution : From the graph we can see that,

- (i) At the end of five weeks, the height of plant in pot A is 12 cm and that in pot B is 10 cm.
- (ii) The height of the plant in pot A increased by 3 cm at the end of two weeks. This was more than the increase in any subsequent week.
- (iii) The height of the plant in pot B at the end of week 4 was 8 cm.

Example-2. The following graph shows the runs scored by teams A and B in a 20-20 match. Answer the following questions with the help of the given graph:-

- (i) How many runs were scored by team A at the end of over 16?
- (ii) What are the intervals when the rates of scoring runs were fastest for team A and team B?
- (iii) What are the intervals when the rates of scoring runs were slowest for team A and team B?
- (iv) What was the difference in scores of team A and team B at the end of over 8?
- (v) By looking at the graph can you tell which team won?

Solution :

- (i) Team A had scored 126 runs by the end of over 16.
- (ii) The rates of scoring runs were fastest for team A and team B between overs 16 and 20.
- (iii) Team A scored slowest between overs 4 and 8; team B scored slowest between overs 8 and 12.
- (iv) The difference in scores of team A and team B at the end of over 8 was 6 runs.
- (v) The graph clearly shows that team B won.

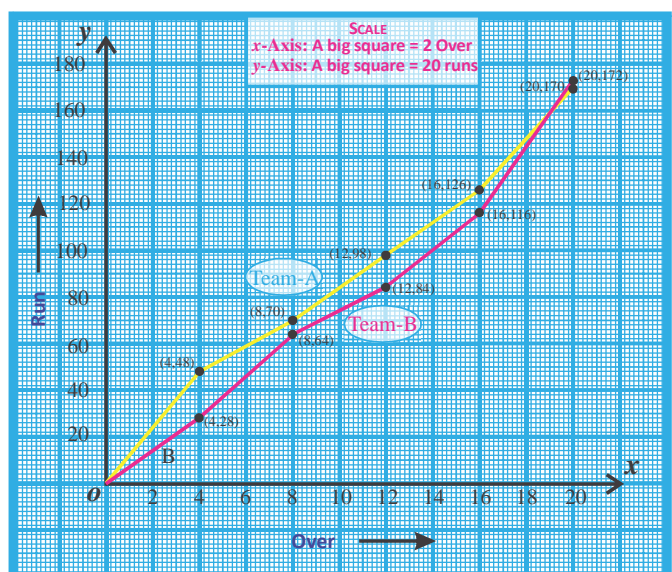

Graph - 10



Try this

Show the runs scored by you and your friends in a cricket match on a graph.

Exercise-1



- Look at graphs (A) and (B) given below. Graph (A) is a straight line and graph (B) is a curve.

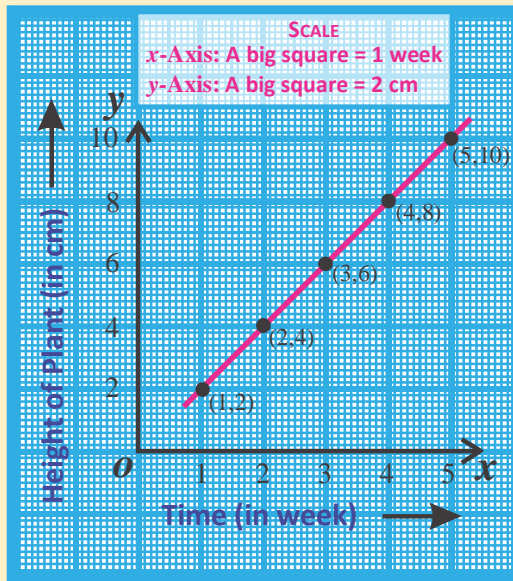

Graph - A

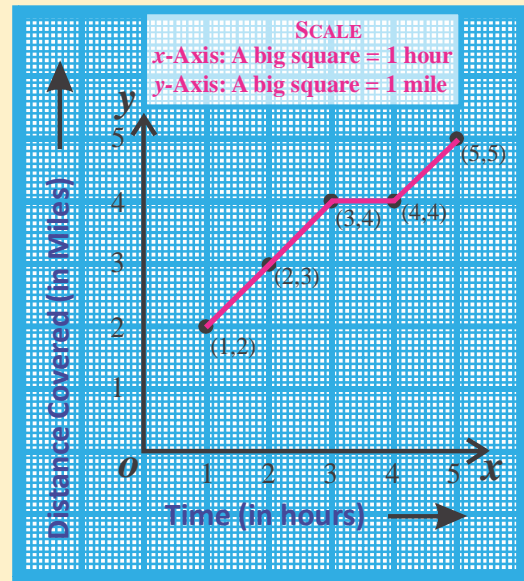

Graph - B

- What conclusions can you draw from graph (A)?
 - How are these conclusions different from those drawn from graph (B)?
- A man filled 5 liters of petrol in the fuel tank of his vehicle. The table below shows the days and the petrol remaining on that day-

Day	1	2	3	4	5
Vlume of petrol remaining (l)	4	3	2	1	0

Draw a graph between the petrol remaining and number of days.

- The table below shows simple interests on a deposit of Rs.300 at the interest rate of 5 percent per annum.

Time (in years)	0	1	2	3	4	5
Simple Interest (in rupees)	0	15	30	45	60	75

Draw a graph between time and simple interest.

4. Find the value of x^2 for different values of x and draw a graph between x and x^2 . The values of x are integer numbers between -4 and $+4$.
5. The table below shows the quantities of onions consumed (in kg) over 5 weeks by a family.

Week	1	2	3	4	5
Quantity of onion (in kg)	1	2	3	4	5

Draw a graph between week and quantity of onion consumed.

6. According to an article published in a science magazine the speed of ants in a particular place is effected by the temperature of that place. If equation $s = \frac{t - 20}{5}$ shows the relation between the temperature of a place and the speed of ants where temperature, t is in $^{\circ}\text{C}$ and speed, s is in cm per second, then draw the graph between speed of ants and temperature using $t = 25^{\circ}, 30, 35^{\circ}, 40-$
- Which quantity was taken on the X-axis?
 - Which quantity was taken on the Y-axis?
 - What was the scale used to depict the quantities on x and Y-axis?
 - What is the temperature of the place where the speed of ants is 2.5 cm per second?
 - What will be the change in speed of ants if the temperature increases to 40°C from 30°C ?
7. Anita made some musical instruments using pipes of different lengths. The mathematical relation between length of pipe (in cm) and the pitch (cycles per second) of music is shown in the table below:

Pitch (cycles per second)	64	128	192	261	300	395	438	512
Length of pipe (in cm)	80	41	26	19	18	13	12	10

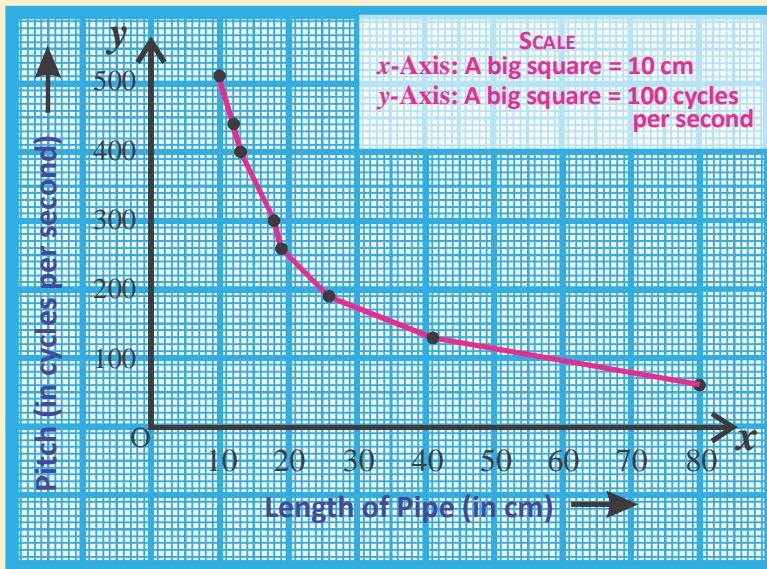

Look at the graph and answer the following questions:

- What should be the length of pipe to obtain a pitch of 160 cycles per second?
- What will be the pitch when the length of pipe is 60 cm?

8. Two tables, A and B are given below. Draw graphs for quantities shown in the tables and find out whether $\frac{Y_2 - Y_1}{X_2 - X_1}$ is constant?

Table - A

	X_1	X_2	X_3	X_4	X_5
Radius of a circle, r (in cm)	2	4	6	8	10
Perimeter of a circle, $2\pi r$ (in cm)	4π	8π	12π	16π	20π
	Y_1	Y_2	Y_3	Y_4	Y_5

Table - B

	X_1	X_2	X_3	X_4	X_5
Radius of a circle, r (in cm)	1	2	3	4	5
Area of a circle, $A = \pi r^2$ (in cm^2)	π	4π	9π	16π	25π
	Y_1	Y_2	Y_3	Y_4	Y_5

9. The temperature data for a particular day in a city are shown in the graph. Answer the following questions based on the graph:

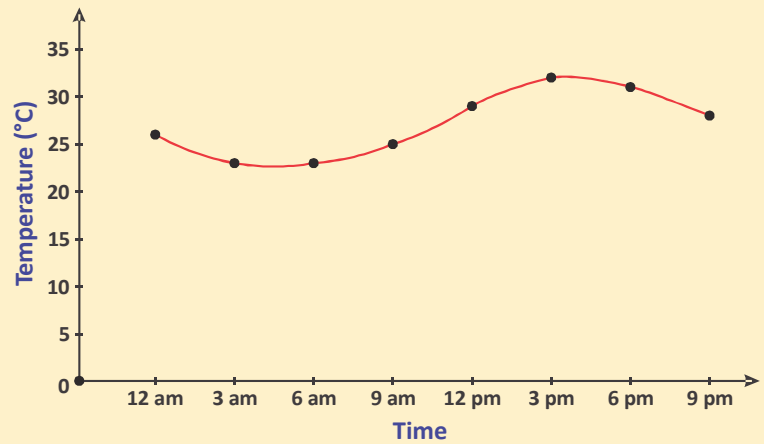

- (i) What was the city temperature at 6 am?
- (ii) What was the city temperature at 3 pm in the afternoon?
- (iii) At what time was the temperature 30°C?
- (iv) What would have been the temperature at 12 midnight?
- (v) What was the temperature at 9 pm in the night?

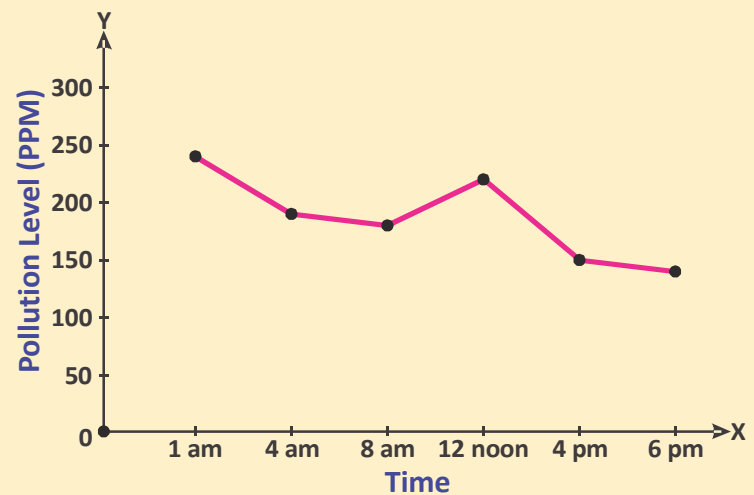

10. The pollutions levels of a city were monitored throughout a day. The pollution levels are shown in a graph; answer the following questions based on the graph:-

- (i) What was the pollution level at 8 in the morning?
- (ii) At what time was the highest pollution level recorded?
- (iii) What was the pollution level in the afternoon, at 4 o'clock?
- (iv) What was the change in pollution level from 12 o'clock noon to 6 o'clock in the evening?
- (v) By how much did the pollution level decrease from 1 o'clock at night to 4 o'clock in the morning?



1. We learnt to understand the relation between any two quantities using a graph.
2. How to make a graph for given data, how to select the axis for each quantity and how to decide the scale for the graph.
3. Reading graphs describing different situations.
4. Drawing conclusions from a given graph.



BANKING AND TAXATION

CHAPTER

08

Introduction

Gokul was talking with his friends. They were discussing that each month they were able to save some money. They wondered where to keep it safely so that it would be available when they needed it.

Mohan – I think we should open a savings account.

Ajmal – It would be better if we open a recurring deposit account; we will get more interest.

Naresh – But, we will have to deposit some money every month in a recurring deposit account.

Gokul – We can easily do that for the next few months.

Ajmal – Good! Let us deposit a fixed amount of money for the next six months.

Gokul – How much money? Where should I deposit it? Can I deposit only for six months?

Naresh – No. You can go up to 10 years and deposit in a bank or even a post-office. Not only this, you can open more than one account. Just be careful that the money deposited should be a multiple of ten.

Gokul – What are the benefits of depositing for a longer period?

Naresh – The interest rates are higher; the longer the period the higher is the interest rate.

Rakesh – And suppose I want to withdraw money before the period ends or if I don't have enough money for the installment?

Naresh – Every year you can withdraw a limited sum. We will have to ask the bank about what will happen if we don't deposit the installment. But if you have to close the account, then they will deduct some money from your interest and return the rest.



Garima – Is there some other type of account that gives even more interest?

Rakesh – Yes, you can open a fixed deposit account. But here, you have to deposit the money for a fixed period.

Garima – How do I decide whether to put my savings in a recurring deposit account or a fixed deposit?

Rakesh – If you don't need your savings in the near future then you can open a fixed deposit account, otherwise go for a recurring deposit account.

Try This



You must have read about simple interest in previous classes. Let us solve some examples to understand the differences between savings, recurring deposit and fixed deposit accounts.

1. Mahesh deposits ₹300 every month, for three months, in his savings account. Ekta deposits ₹100 every month for three months in her recurring deposit account, depositing a total of ₹300. If :
 - a. the rate of interest per annum in the savings account is 4% and it is 6% in the recurring deposit account, which one will give more interest?
 - b. the rates of interest in both the accounts is 6%, then will there be any difference in the interest amounts? If yes, then what is the reason for the difference?
2. Manisha deposits ₹2000 in her savings account for two years on which she gets interest at the rate of 4% per annum. Rohan deposits ₹2000 in a fixed deposit account for 2 years and gets interest at the rate of 8% per annum. What will the interest amount earned by Manisha and Rohan at the end of two years?

We can summarize the differences in the three types of accounts as follows:

When we have some savings which we may need at any time then we should put them in a savings account. We open a fixed deposit account when we feel that we will not need our savings in the coming six months, one-two years or for some fixed duration.

The money deposited in a savings account can be withdrawn anytime so the bank can't use this money and therefore the rate of interest is less. But for the money deposited in a fixed deposit account, the bank knows that it can use it for the duration of the account and therefore the rate of interest is higher.

Recurring deposit account is different from the other two accounts as the person depositing does not have a very large sum of money to start with. She has some savings and she wants to continuously save this same amount every month for a fixed period. In such a

situation, a recurring deposit account is a good option. The rate of interest is higher than a savings account because here also the duration is fixed.

Let us understand recurring deposit accounts through some examples.

Example-1. Santosh Kumar opened a recurring deposit account for six months where he had to deposit ₹100 every month. If the annual rate of interest is 6% then what will be the maturity amount at the end of six months?

Solution : (i) Interest earned on the first installment of ₹100 (Interest on ₹100 for 6 months at the rate of 6%)

$$= \frac{100 \times 6 \times 6 \times \frac{1}{12}}{100}$$

(ii) Interest on the second installment of ₹100 (Interest on ₹100 for 5 months at the rate of 6%)

$$= \frac{100 \times 6 \times 5 \times \frac{1}{12}}{100}$$

(iii) Interest on the third installment of ₹100 (Interest on ₹100 for 4 months at the rate of 6%)

$$= \frac{100 \times 6 \times 4 \times \frac{1}{12}}{100}$$

(iv) Interest on the fourth installment of ₹100 (Interest on ₹100 for 3 months at the rate of 6%)

$$= \frac{100 \times 6 \times 3 \times \frac{1}{12}}{100}$$

(v) Interest on the fifth installment of ₹100 (Interest on ₹100 for 2 months at the rate of 6%)

$$= \frac{100 \times 6 \times 2 \times \frac{1}{12}}{100}$$

(vi) Interest on the sixth and last installment (Interest on ₹100 for 1 month at the rate of 6%)

$$= \frac{100 \times 6 \times 1 \times \frac{1}{12}}{100}$$

Total interest =

$$\left[\frac{100 \times 6 \times 6 \times \frac{1}{12}}{100} + \frac{100 \times 6 \times 5 \times \frac{1}{12}}{100} + \frac{100 \times 6 \times 4 \times \frac{1}{12}}{100} + \frac{100 \times 6 \times 3 \times \frac{1}{12}}{100} + \frac{100 \times 6 \times 2 \times \frac{1}{12}}{100} + \frac{100 \times 6 \times 1 \times \frac{1}{12}}{100} \right]$$

$$= \frac{100 \times 6 \times \frac{1}{12}}{100} [6 + 5 + 4 + 3 + 2 + 1]$$

$$= \frac{100 \times 6 \times \frac{1}{12}}{100} [1 + 2 + 3 + 4 + 5 + 6]$$

$$= \frac{100 \times 6 \times \frac{1}{12} \times 6 \times 7}{100 \times 2} \quad (\text{using the formula for sum of a finite arithmetic series})$$

$$= \frac{21}{2} = ₹10.50$$

The total sum of money obtained after six months = $100 \times 6 + 10.50 = ₹610.50$

Example-2. If ₹ P is deposited for n months at the interest rate of $r\%$ per annum then calculate the interest obtained on the recurring deposit account after n months.

Solution :

Interest on ₹ P after n months at the interest rate $r\%$ per annum (interest on first installment)

$$= \frac{P \times r}{100} \times \frac{n}{12} \quad (\text{because the bank kept this money for } n \text{ months})$$

Interest on ₹P after $(n-1)$ months at $r\%$ interest rate (interest on second installment)

$$= \frac{P \times r}{100} \times \frac{n-1}{12} \quad (\text{because the bank keeps this money for } n-1 \text{ months})$$

Interest on ₹P after $(n-2)$ months at $r\%$ interest rate (interest on third installment)

$$= \frac{P \times r}{100} \times \frac{n-2}{12} \quad (\text{because the bank keeps this money for } n-2 \text{ months})$$

.....

Similarly, interest on ₹ P in the penultimate month (that is, in $(n-(n-2))^{\text{th}}$ month) at $r\%$ interest rate (interest on the second last installment)

$$= \frac{P \times r}{100} \times \frac{2}{12} \quad (\text{because this money is with the bank for 2 months})$$

Interest on ₹ P in the last month at $r\%$ interest rate (interest on the last installment)

$$= \frac{P \times r}{100} \times \frac{1}{12} \quad (\text{because the bank keeps this money for 1 month})$$

$$\text{Total interest} = \frac{P \times r}{100} \times \frac{1}{12} [n + (n-1) + (n-2) + \dots + 2 + 1]$$

$$= \frac{P \times r}{100} \times \frac{1}{12} \left[\frac{n(n+1)}{2} \right]$$

$$= \frac{P \times r}{100} \times \frac{1}{12} \left[\frac{n(n+1)}{2} \right] \quad (\text{because it is an arithmetic progression})$$

∴ the total interest on an amount saved in a recurring deposit account =

$$= \frac{P \times r}{100} \times \frac{1}{12} \left[\frac{n(n+1)}{2} \right]$$

Where P = monthly installment amount r = rate of interest

n = total number of monthly installments

Let us now understand the calculation of interest on a fixed deposit account through some examples

Compound interest is applicable on the amount deposited in a fixed deposit account and it is given by the following formula:

$$A = P \left(1 + \frac{r}{100} \right)^n$$

Where A = total amount, P = principal amount, r = rate of interest and n = time

Log tables can be used for calculations.

Example-3. Nikhil deposited ₹10,000 for 1 year and six months in a fixed deposit account in a *Grameen* (Rural) Bank. If the rate of interest per annum is 8%, compounded semi-annually, then find the maturity amount in Nikhil's account at the end of 18 months.

Solution : Given,

Principal, P = ₹10,000, Rate of interest = 8% per annum or 4% semi-annually

Time = 1 year 6 months = 3 half-years

Total amount, A = ?

$$\therefore \text{Total amount, } A = P \left(1 + \frac{r}{100} \right)^n$$

$$\therefore \text{Total amount, } A = 10000 \left(1 + \frac{4}{100}\right)^3$$

$$A = 10000 \left(1 + \frac{1}{25}\right)^3$$

$$A = 10000 \left(\frac{26}{25}\right)^3$$

$$A = 10000 \times \frac{26}{25} \times \frac{26}{25} \times \frac{26}{25}$$

$$A = ₹11248.64$$

Therefore, the total amount or principal due Nikhil will be ₹11248.64.

Example-4. Mohan deposited ₹50000 for two years in a fixed deposit account in an Agricultural Development Bank. If the rate of interest per annum is 10% and interest is compounded every six months, then on maturity how much money will the bank give Mohan?

Solution : Given,

Principal, $P = ₹50,000$, Rate of interest = 10% per annum or 5% semi-annually

Time = 2 years = 4 half-years

Total amount, $A = ?$

$$A = P \left(1 + \frac{r}{100}\right)^n$$

$$\therefore \text{Total amount, } A = 50000 \left(1 + \frac{5}{100}\right)^4$$

$$A = 50000 \left(1 + \frac{1}{20}\right)^4$$

$$A = 50000 \left(\frac{21}{20}\right)^4$$

$$A = 50000 \times \frac{21}{20} \times \frac{21}{20} \times \frac{21}{20} \times \frac{21}{20}$$

$$A = ₹60775.31$$

Thus, Mohan will get ₹60775.31 as maturity amount after two years.

Exercise-1

1. Karim deposits ₹150 every month for 2 years in his recurring deposit account in State Bank of India. If the rate of interest is 5% per annum then how much money will be paid to Karim by the bank after 2 years?
2. Reshma opened a recurring deposit account in Punjab National bank for five years and deposits ₹200 every month. If the rate of interest is 6% per annum then how much money will she get after 5 years?
3. Rohan opened a recurring deposit account in a post-office and deposited ₹50 every month for 5 years. How much money will he get if the rate of interest is 5% per annum?
4. Padmini opened a recurring deposit account in District Cooperative Bank for ten years and her monthly installment is ₹100. If on maturity she gets ₹3025 as interest, what is the rate of interest per annum?
5. If Kishan opens a recurring deposit account in some bank branch for three years and deposits a monthly installment of ₹250, then how much money will he get if the rate of interest is 5% per annum?
6. Rajat opened a recurring deposit account in a branch of Central Bank of India and deposited ₹100 every month for 3 years. What rate of interest per annum will yield an interest of ₹222 on maturity?
7. Kishan deposits ₹ 20,000 for 1 year as fixed deposit in Allahabad Bank at an interest rate of 16% per annum. If the interest is compounded every three months, how much money will Kishan get on maturity?
8. Hemchand deposits ₹ 1,00,000 for 1 year and six months as fixed deposit in a Rural Bank at an interest rate of 8% per annum. If the interest is compounded every three months, how much money will Hemchand get on maturity?
9. If a person saves ₹ 2 lakhs for two years in a fixed deposit account at 4% interest rate per annum, what amount will he get on maturity if interest is compounded annually?
10. Nilesh opens a fixed deposit account for one year in Bank of India and deposits ₹50000 at 8% rate of interest. If interest is compounded quarterly then how much money will the bank pay to Nilesh after one year?
11. Pushpa saved ₹60000 for one year six months in a fixed deposit account. How much money will she get on maturity if the rate of interest is 12% per annum and interest is compounded after every six months?
12. Sriram deposited ₹20000 for two years in a fixed deposit account. If the annual rate of interest is 6% per annum and the interest is compounded every six months then what amount will Sriram get after due date?

ANSWER KEY - 1

- | | | | |
|-----------------|---------------|----------------|-----------------|
| 1. ₹3787.50 | 2. ₹13830 | 3. ₹3381.25 | 4. 5% |
| 5. ₹9693.75 | 6. 4% | 7. ₹23,397.17 | 8. ₹1,12,616.24 |
| 9. ₹2,16,320.00 | 10. ₹54121.60 | 11. ₹71,460.96 | 12. ₹22510.17 |

Taxation

Introduction

The Indian Government needs to carry out a number of activities for the welfare of its citizens. To do so, it requires money. Can you tell; From where does the government get the money to carry out these activities?

To obtain this money, the government levies different kinds of taxes on its citizens; for example, income tax, service tax, sales tax etc. The amount of tax is pre-decided.



Think and discuss

From where else can the government get money to carry out development work?

Do you know what income tax is?

The Indian Government gets its revenue from various sources and a big part of this money is derived from income tax. To collect income tax, the government first specifies a minimum limit. People, industries and organization whose income is more than the specified limit set by the government have to pay income tax. But those individuals, industries and organization whose income is less than this limit do not have to pay income tax. For different levels (slabs) of income, the government specifies different rates of income tax and the income tax has to be paid according to this rate. But for some special categories of persons, companies and industries, income tax rebates are also provided.

The rate of income tax increases with increase in income. This increased rate is levied on the income that falls beyond the minimum limit specified. There can be one or more than one source of income for persons, industries and companies and income and income tax are calculated based on the sum of the incomes from all the sources. Sometimes, for special activities, the government levies a little extra tax in addition to income tax and this is called Cess. It is compulsory for all individuals, companies and industries that fall within the income tax limit to pay taxes.

Is there an account number for identifying a tax payer?

The income tax department established by the Govt. of India collects taxes from tax payers. Now, the question is: How does the income tax department identify or recognize tax payers? For tax payer identification, the department issues a permanent account number (PAN) or temporary account number (TAN) to all individuals, organizations or companies.

PAN is mandatory for opening a bank account so that the income tax department can collect information about the income of account holders.

Tax is levied at what rate and over which period?

A person has to pay tax on the income generated, from all sources, in the period between 1st April and 31st March. This period or duration is known as the financial year. For calculation of income tax, the government decides tax rates which can change with change in financial year.

- (1) Let us look at the tax rates table for the last three years which shows how the tax rates have changed over time:-

Financial year	Male		Female		Senior Citizen	
	Taxable Income	Rates of income tax	Taxable Income	Rates of income tax	Taxable Income	Rates of income tax
2013-2014	Up to 2 lacs	NIL	Up to 2 lacs	NIL	Up to 2 lacs	NIL
	2,00,001 to 5,00,000	10%	2,00,001 to 5,00,000	10%	2,00,001 to 5,00,000	10%
	5,00,001 to 10,00,000	20%	5,00,001 to 10,00,000	20%	5,00,001 to 10,00,000	20%
	Above 10 lacs	30%	Above 10 lacs	30%	Above 10 lacs	30%
2014-2015	Up to 2 lacs	NIL	Up to 3 lacs	NIL	Up to 3 lacs	NIL
	2,00,001 to 5,00,000	10%	3,00,001 to 5,00,000	10%	3,00,001 to 5,00,000	10%
	5,00,001 to 10,00,000	20%	5,00,001 to 10,00,000	20%	5,00,001 to 10,00,000	20%
	Above 10 lacs	30%	Above 10 lacs	30%	Above 10 lacs	30%
2015-2016	Up to 2 lacs	NIL	Up to 3 lacs	NIL	Up to 3 lacs	NIL
	2,00,001 to 5,00,000	10%	3,00,001 to 5,00,000	10%	3,00,001 to 5,00,000	10%
	5,00,001 to 10,00,000	20%	5,00,001 to 10,00,000	20%	5,00,001 to 10,00,000	20%
	Above 10 lacs	30%	Above 10 lacs	30%	Above 10 lacs	30%

- (2) Currently, educational sub-tax or cess is 2% for middle school and 1% for higher education and the total educational cess is 3%.
- (3) If the taxable income is more than 10 lacs then an additional 10% surcharge is levied on the payable tax.
- (4) As per Section 80C of income tax Act of 1961, the maximum exemption/rebates on savings is ₹1.5 lacs, which is deducted from the gross salary. The amount remaining after deduction is used for calculating tax.

The following investments are eligible for tax exemptions (rebates):

- (1) Annual premium on Life Insurance policy
- (2) Annual premium of ULIP (Unit Linked Insurance Plan)
- (3) Annual contribution to General Provident Fund
- (4) Home Loan Installments
- (5) Tuition/education fees of children
- (6) Payments made towards fixed deposits with a minimum tenure of five years
- (7) Annual subscriptions to group policies and family welfare schemes

Let us understand calculation of income tax through some examples.

Example-1. The income of a person in the financial year 2008-2009 was ₹4,28,000. She deposited ₹2500 every month in general provident fund and ₹25000 as semi-annual premium of life insurance policy. She purchased a National Savings Certificate worth ₹30,000 and donated ₹25,000 to a charitable trust. Calculate the income tax paid by the person at the end of the financial year. According to Section 80C of income tax act, a total of ₹1,00,000 is eligible for exemption as savings under general provident fund, National Savings Certificate and LIC etc. As per section 80G, 50 percent of the donation is also eligible for tax rebates. The rates of tax are as follows:

S.No.	Tax Limits	Rate of Tax
1.	Up to ₹ 1,50,000	NIL
2.	₹ 1,50,001 to ₹ 3,00,000	10%
3.	₹ 3,00,0001 to ₹ 5,00,000	20%

In addition, a 3% educational cess or sub-tax will be levied on income tax.

$$\begin{aligned}
 \text{Solution : Total income of the person} &= ₹4,28,000 \\
 \text{Exemption allowed on amount donated to trust} &= 50\% \text{ of } ₹25000 \\
 &= \frac{25000 \times 50}{100} \\
 \text{Rebate} &= ₹12,500 \\
 \text{Remaining income} &= ₹(4,28,000 - 12,500) = ₹4,15,500
 \end{aligned}$$

$$\begin{aligned}
 \text{Amount exempted under Section 80C of income tax act} &= \text{general provident fund} + \\
 &\quad \text{life insurance policy premium} + \text{national savings certificate} \\
 &= 2500 \times 12 + 25000 \times 2 + 30,000 \\
 &= 30,000 + 50,000 + 30,000 \\
 &= \text{which is more than ₹1,00,000}
 \end{aligned}$$

Maximum exemption permitted is ₹1,00,000

$$\begin{aligned}
 \text{Therefore, taxable income} &= ₹4,15,500 - ₹1,00,000 \\
 &= ₹3,15,500
 \end{aligned}$$

According to given tax rates, tax on upto ₹1,50,000 = NIL

$$\begin{aligned}
 \text{Income tax} &= 10\% \text{ of ₹150000} + 20\% \text{ of ₹15500} \\
 &= ₹15,000 + ₹3100 \\
 &= ₹18,100 \\
 \text{Educational cess} &= 3\% \text{ of ₹18100} \\
 &= ₹543 \\
 \text{Total payable tax} &= ₹18,100 + ₹543 \\
 &= ₹18643
 \end{aligned}$$

Example-2 The income of a person in the financial year 2012-2013 is ₹4,80,000 (not including house rent allowance). He deposited ₹36000 in provident fund, ₹20,000 in the National Savings Certificate plan and ₹18000 as premium on life insurance policy. In addition, he had to pay 3% educational cess on income tax. If he pays ₹1500 every month for 10 months towards income tax, then what is the amount of payable tax remaining? Up to ₹1,00,000 of savings under provident fund, Life Insurance and National Savings Certificate are exempt from tax. The rates of tax are as follows:

S.No.	Tax Limits	Rate of Tax
1.	Upto ₹2,00,000	NIL
2.	₹2,00,001 to ₹5,00,000	10%

Solution : Annual income = ₹480000

$$\begin{aligned}
 1. \quad \text{Amount saved under provident funds} &= ₹36000 \\
 2. \quad \text{Amount saved under life insurance policy} &= ₹18,000 \\
 3. \quad \text{Amount saved under national savings certificate} &= ₹20,000 \\
 \text{Total amount saved} &= ₹36,000 + ₹18,000 + ₹20,000 \\
 &= ₹74,000
 \end{aligned}$$

$$\text{Taxable income} = ₹4,80,000 - ₹74,000 = ₹4,06,000$$

$$\text{Income tax} = 10\% \text{ of } (₹4,06,000 - ₹2,00,000) \quad (\because \text{No tax is levied on income up to } ₹2,00,000)$$

$$= \frac{206000 \times 10}{100}$$

$$= ₹20,600$$

$$\text{Education cess} = 3\% \text{ of } ₹20,600$$

$$= \frac{20600 \times 3}{100}$$

$$= ₹618$$

$$\text{Total payable income tax} = ₹20,600 + ₹618 = ₹21,218$$

$$\text{Income tax deposited over 10 months} = ₹1,500 \times 10 = ₹15,000$$

$$\text{Remaining Income tax due} = ₹21,218 - ₹15,000$$

$$= ₹6,218$$

Example-3. The income of a government employee in the financial year 2013-2014 was ₹3,60,000. She deposited ₹20,000 as premium on life insurance policy and ₹4,000 every month in general provident fund. Calculate the payable tax.

Also, a maximum of ₹1,00,000 of savings under provident fund, Life Insurance and National Savings Certificate are exempt from tax.

The rates of tax are as follows:

S.No.	Tax Limits	Rate of Tax
1.	Upto ₹2,00,000	NIL
2.	₹2,00,001 to ₹5,00,000	10%
3.	₹5,00,001 to ₹10,00,000	20%

3% of payable tax is educational sub-tax.

Solution: Annual income of the government employee = ₹3,60,000

1. Amount saved under provident funds = ₹48,000

2. Amount saved under life insurance policy = ₹20,000

$$\text{Total amount saved} = ₹48,000 + ₹20,000$$

$$= ₹68,000$$

Since, maximum permissible rebate is 1,00,000 therefore tax need not be paid on

$$= ₹68,000$$

$$\text{Taxable income} = ₹3,60,000 - ₹68,000 = ₹2,92,000$$

Income tax = 10% of ₹(2,92,000 – 2,00,000) (\because No tax is levied on income up to ₹200000)

= 10% of ₹92,000

= ₹9,200

Education cess = 3% of income tax

= $\frac{9200 \times 3}{100}$

= ₹276

Total payable income tax = ₹9,200 + ₹276 = ₹9,476

Exercise - 2



- The income (excluding house rent allowance) of a government employee in the financial year 2013-2014 was ₹4,10,000. He deposited ₹20000 as premium on life insurance policy and ₹4000 every month in general provident fund. He also purchased a national savings certificate worth ₹25000. He donates ₹ 20,000 to the Primeminister's Relief Fund (which is 100% tax free) and ₹12,000 to Old Persons's Home (which gets him 50% tax rebate). Calculate the payable tax for him at the end of the year. A maximum of ₹1,00,000 of savings (under any scheme) are permitted. The rates of tax are as follows:

S.No.	Tax Limits	Rate of Tax
1.	Upto ₹2,00,000	NIL
2.	₹2,00,001 to ₹5,00,000	10%
3.	₹5,00,001 to ₹10,00,000	20%

- Educational cess = 2% of payable tax
 - Secondary and Higher education tax = 1% of payable tax
- Naveen's income in the financial year 2013-2014 was ₹7,20,000. He deposited ₹20000 as premium on life insurance policy and ₹4000 every month in general provident fund. He also purchased a national savings certificate worth ₹30000. He donates ₹ 15,000 to an orphanage (which is 50% tax free). Calculate the tax payable by him at the end of the year.

The rates of tax are as follows:

S.No.	Tax Limits	Rate of Tax
1.	Up to ₹2,00,000	NIL
2.	₹2,00,001 to ₹5,00,000	10%
3.	₹5,00,001 to ₹10,00,000	20%
4.	Over ₹10,00,001	30%

- Educational cess = 2% of payable tax
- Secondary and Higher education tax = 1% of payable tax
- A maximum of ₹1,00,000 of savings (under any scheme) are eligible for tax rebate.
- Ramesh's total annual income in the financial year 2008-2009 was ₹3,00,000. He deposited ₹1000 every month in general provident fund and paid an annual premium of ₹12,000 on life insurance policy. If there is no tax on income up to ₹ 1,50,000 and 10% tax on income above ₹ 1,50,000 and maximum savings permissible under all schemes are ₹1,00,000 then calculate the tax payable by him at the end of the year where the educational sub-tax is 3% of income tax.
- The monthly income (excluding house rent allowance) of a bank employee in the financial year 2014-2015 was ₹40,000. He deposits ₹42,000 annually in general provident fund and ₹6000 as semi-annual premium on life insurance policy. If he pays ₹1600 every month for 11 months towards income tax, then what is the amount of payable tax remaining in the last month of the year? 100% of all savings (maximum of ₹1,00,000) are tax-exempt.

A. The rates of tax are as follows:

S.No.	Tax Limits	Rate of Tax
1.	Up to ₹2,50,000	NIL
2.	₹2,50,001 to ₹5,00,000	10%
3.	₹5,00,001 to ₹10,00,000	20%
4.	More than ₹10,00,001	30%

- Cess = 10% of payable tax if annual taxable income is more than 10 lakhs,
- Education tax = 3% of payable tax
- Rajesh's total annual income in the financial year 2012-2013 was ₹5,25,000. He deposited ₹8000 every month in general provident fund and paid an annual premium of ₹8,000 on life insurance policy. If there is no tax on income up to ₹2,00,000 and 10% tax on income above ₹2,00,000 and maximum savings permissible is 100%

under all schemes (up to ₹1,00,000) then calculate the tax payable by Rajesh at the end of the year where the educational sub-tax is 3% of income tax.

6. In the financial year 2014-2015, the annual income of Mrs. Bhawna (not including house rent allowance) was ₹ 6,00,000. She deposits ₹ 48,000 every year in general provident fund and ₹25,000 as annual premium on life insurance policy. If she pays ₹1500 every month for the first 11 months towards income-tax and ₹1,00,000 is allowed as savings under all saving schemes then calculate the payable income tax due.

The rates of income-tax are as follows:

S.No.	Tax Limits	Rate of Tax
1.	Up to ₹2,50,000	NIL
2.	₹2,50,001 to ₹5,00,000	10%
3.	₹5,00,001 to ₹10,00,000	20%

In addition, a 3% education sub-tax has to be paid over the income tax.

7. An officer's annual income (excluding house rent allowance) in the financial year 2012-2013 is ₹7,20,000. She deposits ₹3000 every month towards premium on life insurance policy, ₹4000 every month in general provident fund and also purchased a national savings certificate worth ₹30000. She donated ₹20,000 to an orphanage and 50% of this donation is eligible for tax rebate. If a maximum of ₹1,00,000 can be invested in any type of savings to qualify for tax rebate, then calculate the tax she has to pay at the end of the year.

A. The rates of tax are as follows:

S.No.	Tax Limits	Rate of Tax
1.	Up to ₹2,00,000	NIL
2.	₹ 2,00,001 to ₹5,00,000	10%
3.	₹ 5,00,001 to ₹10,00,000	20%
4.	More than 10,00,001	30%

B. Education tax = 3% of payable tax

ANSWER KEY

1. Total income tax ₹8,961
2. Total income tax ₹54,487
3. Total income tax ₹12,978
4. Total income tax ₹18,128 and the tax due in the last month is ₹528.
5. Total income tax ₹23,175 and education sub-tax is ₹675.
6. Total income tax ₹31,312 and education sub-tax is ₹912.
7. Total income tax ₹53,560 and education sub-tax is ₹1,560.

TRIGONOMETRIC EQUATION AND IDENTITIES

We studied trigonometric ratios $\sin\theta$, $\cos\theta$, $\tan\theta$, $\cot\theta$, $\sec\theta$ and $\operatorname{cosec}\theta$ in class 9th. These ratios can be found for any angle, but here we will discuss trigonometric ratios of acute angles only.

Look at figure-1(i). Here, in $\triangle ABC$ consider angle B. Is it possible to identify all the trigonometric ratios at $\angle B = \theta$?

To find all the trigonometric ratios for angle θ , we have to make a right angle triangle including the angle θ .

How can we make right angle triangle $\triangle ABC$ which includes angle θ ?

In $\triangle ABC$ we will draw the perpendicular AD on side BC from the vertex A . In the right angle triangles ADB and ADC so obtained (figure-1(ii)), complete the following table for acute angles θ and θ_1 .

$\sin\theta$	$\cos\theta$	$\tan\theta$	$\cot\theta$	$\sec\theta$	$\operatorname{cosec}\theta$
$\frac{AD}{AB}$					
$\sin\theta_1$	$\cos\theta_1$	$\tan\theta_1$	$\cot\theta_1$	$\sec\theta_1$	$\operatorname{cosec}\theta_1$
$\frac{CD}{AC}$					

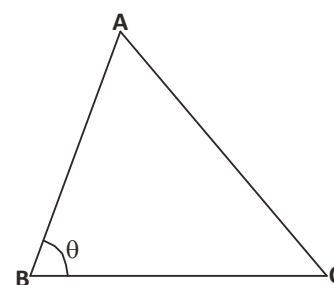

Figure - 1(i)

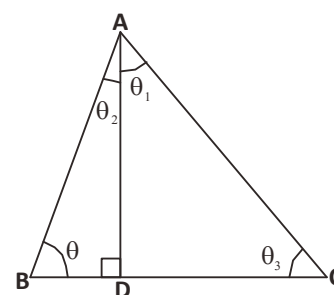

Figure - 1(ii)

Try These

Find all the trigonometric ratios at angle θ_2 and θ_3 in $\triangle ABC$.



Think and Discuss



In the adjacent figure, how will you find the trigonometric ratios for angle $\angle XYZ = \theta$?

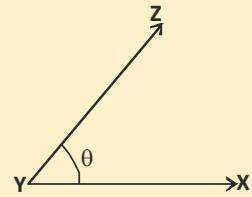

Relations Between Trigonometric Ratios

In previous classes we learnt about some relations between the trigonometric ratios. Let us find some more relations between these trigonometric ratios.

We have right angle $\triangle ABC$ in which $\angle C$ is the right angle. By Pythagoras theorem (figure-2),

$$AC^2 + BC^2 = AB^2 \quad \dots(1)$$

Dividing the above equation by AB^2

$$\frac{AC^2}{AB^2} + \frac{BC^2}{AB^2} = \frac{AB^2}{AB^2}$$

$$\left(\frac{AC}{AB}\right)^2 + \left(\frac{BC}{AB}\right)^2 = \left(\frac{AB}{AB}\right)^2$$

$$(\sin\theta)^2 + (\cos\theta)^2 = 1$$

$$\sin^2\theta + \cos^2\theta = 1 \quad \dots(2)$$

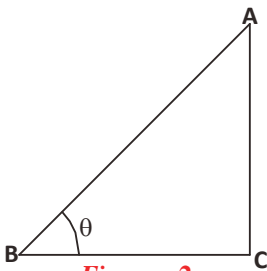

Figure - 2

Is the obtained relation between $\sin\theta$ and $\cos\theta$ true for all the values of θ between 0° to 90° ? Give reasons for your answer.

Try These



- (i) Verify $\sin^2\theta + \cos^2\theta = 1$ for $\theta = 30^\circ, 45^\circ, 60^\circ$.
- (ii) For the given figure, check whether $\sin^2\alpha + \cos^2\alpha = 1$ is true or not.

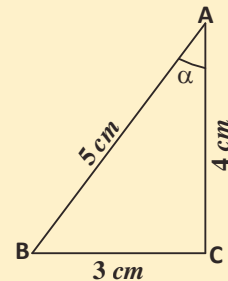

You will find that $\sin^2\theta + \cos^2\theta = 1$ is true for all the value of θ which lie between 0° to 90° .

Are, some other relations possible between the trigonometric ratios? Let us see.

Dividing equation (1) by BC^2

$$\frac{AC^2}{BC^2} + \frac{BC^2}{BC^2} = \frac{AB^2}{BC^2}$$

$$\left(\frac{AC}{BC}\right)^2 + \left(\frac{BC}{BC}\right)^2 = \left(\frac{AB}{BC}\right)^2$$

$$(\tan\theta)^2 + 1 = (\sec\theta)^2$$

$$\tan^2\theta + 1 = \sec^2\theta \quad \dots(2)$$

Is the above relation true for all the angles which lie between 0° and 90° ? Let us check for some angles starting with when $\theta = 0^\circ$

$$\begin{aligned} \text{L.H.S.} &= 1 + \tan^2\theta \\ &= 1 + \tan^2 0^\circ \\ &= 1 + 0 \\ &= 1 \end{aligned}$$

$$\begin{aligned} \text{R.H.S.} &= \sec^2\theta \\ &= \sec^2 0^\circ \\ &= 1 \end{aligned}$$

Hence, it is true at $\theta = 0^\circ$.

Is it also true at $\theta = 90^\circ$? But at $\theta = 90^\circ$ the value of $\tan\theta$ or $\sec\theta$ is not defined therefore we can say that $1 + \tan^2\theta = \sec^2\theta$ is true for all the values of θ except $\theta = 90^\circ$ where θ lies between 0° and 90° i.e. $0 \leq \theta < 90^\circ$.

Let us look at another relation between trigonometric ratios. Dividing equation (1) by AC^2 , we get the following relation:

$$\frac{AC^2}{AC^2} + \frac{BC^2}{AC^2} = \frac{AB^2}{AC^2}$$

$$\left(\frac{AC}{AC}\right)^2 + \left(\frac{BC}{AC}\right)^2 = \left(\frac{AB}{AC}\right)^2$$

$$1 + \cot^2\theta = \text{cosec}^2\theta \quad \dots(3)$$

We know that at $\theta = 0^\circ$, $\cot\theta$ and $\text{cosec}\theta$ are not defined so $1 + \cot^2\theta = \text{cosec}^2\theta$ where $0 < \theta \leq 90^\circ$.



Expressing all trigonometric ratios as any one trigonometric ratio

We have seen the relationship between different trigonometric ratios. Can we convert any trigonometric ratio into another trigonometric ratio? Suppose, we have to express $\cos A$ and $\tan A$ in terms of $\sin A$, then

$$\therefore \sin^2 A + \cos^2 A = 1$$

$$\therefore \cos^2 A = 1 - \sin^2 A$$

$$\cos A = \sqrt{1 - \sin^2 A}$$

$$\text{And } \tan A = \frac{\sin A}{\cos A}$$

$$= \frac{\sin A}{\sqrt{1 - \sin^2 A}}$$

If one trigonometric ratio is known then we can determine the other trigonometric ratios.



Try These

1. Express $\sec A$ in terms of $\sin A$.
2. Express all trigonometric ratios in terms of $\cos A$.

We have studied about different trigonometric identities. Let us think about the relation given below:

$$\cot \theta + \tan \theta = \operatorname{cosec} \theta \cdot \sec \theta$$

Is this correct? How can we verify? Let's try-

$$\cot \theta + \tan \theta = \operatorname{cosec} \theta \cdot \sec \theta$$



$$\begin{aligned} \text{L.H.S.} &= \cot \theta + \tan \theta \\ &= \frac{\cos \theta}{\sin \theta} + \frac{\sin \theta}{\cos \theta} \end{aligned}$$

$$= \frac{\cos^2 \theta + \sin^2 \theta}{\sin \theta \cdot \cos \theta}$$

$$= \frac{1}{\sin \theta \cdot \cos \theta}$$

$$[\because \cos^2 \theta + \sin^2 \theta = 1]$$

$$\begin{aligned}
 &= \frac{1}{\sin\theta} \cdot \frac{1}{\operatorname{cosec}\theta} \\
 &= \operatorname{cosec}\theta \cdot \sec\theta \\
 &= \text{R.H.S.}
 \end{aligned}$$

Let us look at some more examples.

Example-1. Prove that

$$\sin^4\theta - \cos^4\theta = \sin^2\theta - \cos^2\theta$$

Solution : L.H.S. = $\sin^4\theta - \cos^4\theta$

$$\begin{aligned}
 &= (\sin^2\theta)^2 - (\cos^2\theta)^2 && [\because a^2 - b^2 = (a-b)(a+b)] \\
 &= (\sin^2\theta - \cos^2\theta)(\sin^2\theta + \cos^2\theta) && [\because \cos^2\theta + \sin^2\theta = 1] \\
 &= (\sin^2\theta - \cos^2\theta) \cdot 1 \\
 &= \sin^2\theta - \cos^2\theta \\
 &= \text{R.H.S.}
 \end{aligned}$$

Example-2. Prove that-

$$\sqrt{\frac{1+\sin\theta}{1-\sin\theta}} = \frac{1+\sin\theta}{\cos\theta}$$

Solution : L.H.S. = $\sqrt{\frac{1+\sin\theta}{1-\sin\theta}}$

$$\begin{aligned}
 &= \sqrt{\frac{1+\sin\theta}{1-\sin\theta} \times \frac{1+\sin\theta}{1+\sin\theta}} \\
 &= \sqrt{\frac{(1+\sin\theta)^2}{1-\sin^2\theta}} \\
 &= \sqrt{\left(\frac{1+\sin\theta}{\cos\theta}\right)^2} \\
 &= \frac{1+\sin\theta}{\cos\theta} \\
 &= \text{R.H.S.}
 \end{aligned}$$



Example-3. Prove that-

$$\frac{\cos A}{1 - \tan A} + \frac{\sin A}{1 - \cot A} = \sin A + \cos A$$

Solution :

$$\begin{aligned} \text{L.H.S.} &= \frac{\cos A}{1 - \frac{\sin A}{\cos A}} + \frac{\sin A}{1 - \frac{\cos A}{\sin A}} \\ &= \frac{\cos A \cdot \cos A}{\cos A - \sin A} + \frac{\sin A \cdot \sin A}{\sin A - \cos A} \\ &= \frac{\cos^2 A}{\cos A - \sin A} - \frac{\sin^2 A}{\cos A - \sin A} \\ &= \frac{\cos^2 A - \sin^2 A}{\cos A - \sin A} \\ &= \frac{(\cos A - \sin A)(\cos A + \sin A)}{\cos A - \sin A} \\ &= \sin A + \cos A \qquad \qquad \qquad = \text{R.H.S.} \end{aligned}$$

Example-4. Prove that-

$$\frac{1 + \cos \theta - \sin^2 \theta}{\sin \theta + \sin \theta \cdot \cos \theta} = \cot \theta$$

Solution :

$$\begin{aligned} \text{L.H.S.} &= \frac{1 + \cos \theta - \sin^2 \theta}{\sin \theta + \sin \theta \cdot \cos \theta} \\ &= \frac{\cos \theta + 1 - \sin^2 \theta}{\sin \theta (1 + \cos \theta)} \\ &= \frac{\cos \theta + \cos^2 \theta}{\sin \theta (1 + \cos \theta)} \\ &= \frac{\cos \theta (1 + \cos \theta)}{\sin \theta (1 + \cos \theta)} \\ &= \frac{\cos \theta}{\sin \theta} \\ &= \cot \theta \qquad \qquad \qquad = \text{R.H.S.} \end{aligned}$$



Sometimes, we have to prove some relationships with the help of given identities. Let us understand through some examples.

Example-5. If $\sin\theta + \cos\theta = 1$ then prove that $\sin\theta - \cos\theta = \pm 1$

Solution : Given that $\sin\theta + \cos\theta = 1$

$$(\sin\theta + \cos\theta)^2 = 1$$

$$\sin^2\theta + \cos^2\theta + 2 \sin\theta \cdot \cos\theta = 1$$

$$1 + 2\sin\theta \cdot \cos\theta = 1 \quad [\because \sin^2\theta + \cos^2\theta = 1]$$

$$2\sin\theta \cdot \cos\theta = 1 - 1$$

$$\sin\theta \cdot \cos\theta = 0 \quad \dots(1)$$

Again $(\sin\theta - \cos\theta)^2 = 1 - 2 \sin\theta \cdot \cos\theta$

$$(\sin\theta - \cos\theta)^2 = 1 - 2 \times 0 \quad \text{From equation (1)}$$

$$(\sin\theta - \cos\theta)^2 = 1$$

$$\therefore \sin\theta - \cos\theta = \pm 1$$

Hence proved.

Example-6. If $\cos\theta + \sin\theta = \sqrt{2} \cos\theta$

then prove that $\cos\theta - \sin\theta = \sqrt{2} \sin\theta$

Solution : Given that $\cos\theta + \sin\theta = \sqrt{2} \cos\theta$

$$\sin\theta = \sqrt{2} \cos\theta - \cos\theta$$

$$\sin\theta = \cos\theta (\sqrt{2} - 1)$$

$$\frac{\sin\theta}{\sqrt{2} - 1} = \cos\theta$$

$$\cos\theta = \frac{\sin\theta}{\sqrt{2} - 1} \times \frac{\sqrt{2} + 1}{\sqrt{2} + 1}$$

$$\cos\theta = \frac{\sqrt{2} \sin\theta + \sin\theta}{2 - 1}$$

$$\cos\theta = \sqrt{2} \sin\theta + \sin\theta$$

$$\cos\theta - \sin\theta = \sqrt{2} \sin\theta$$

Hence proved.



Forming new Identities

If $x = \sin\theta$
 $y = \cos\theta$

Then, how can we find the relation between x and y ?

We can determine the relation between x and y by eliminating θ , using the trigonometric identities. For example:-

$$x^2 + y^2 = \sin^2\theta + \cos^2\theta$$

$$x^2 + y^2 = 1$$

Let us understand through some more examples.

Example-7. If $x = a \cos\theta - b \sin\theta$ and $y = a \sin\theta + b \cos\theta$
 then prove that $x^2 + y^2 = a^2 + b^2$

Solution : Given $x = a \cos\theta - b \sin\theta$ (1)

$y = a \sin\theta + b \cos\theta$ (2)

By squaring equations (1) and (2)

$$x^2 = (a \cos\theta - b \sin\theta)^2$$

$$y^2 = (a \sin\theta + b \cos\theta)^2$$

$$x^2 = a^2 \cos^2\theta + b^2 \sin^2\theta - 2ab \cos\theta \cdot \sin\theta$$
(3)

$$y^2 = a^2 \sin^2\theta + b^2 \cos^2\theta + 2ab \sin\theta \cdot \cos\theta$$
(4)

By adding equations (3) and (4)

$$x^2 + y^2 = a^2 \cos^2\theta + b^2 \sin^2\theta - 2ab \cos\theta \cdot \sin\theta$$

$$+ a^2 \sin^2\theta + b^2 \cos^2\theta + 2ab \sin\theta \cdot \cos\theta$$

$$= a^2 (\sin^2\theta + \cos^2\theta) + b^2 (\sin^2\theta + \cos^2\theta)$$

$$= a^2 + b^2 \quad [\because \sin^2\theta + \cos^2\theta = 1]$$

Example-8. If $\tan\theta + \sin\theta = m$ and $\tan\theta - \sin\theta = n$ then prove that-

$$m^2 - n^2 = 4\sqrt{mn}$$

Solution : Given $m = \tan\theta + \sin\theta$

$n = \tan\theta - \sin\theta$

$m + n = 2\tan\theta$

$m - n = 2\sin\theta$



Now, $(m-n)(m+n) = 4 \sin\theta \cdot \tan\theta$

$$m^2 - n^2 = 4 \sin\theta \cdot \tan\theta \quad \dots(1)$$

$$m \cdot n = (\tan\theta + \sin\theta)(\tan\theta - \sin\theta)$$

$$= \tan^2\theta - \sin^2\theta$$

$$= \frac{\sin^2\theta}{\cos^2\theta} - \sin^2\theta$$

$$= \frac{\sin^2\theta - \sin^2\theta \cdot \cos^2\theta}{\cos^2\theta}$$

$$= \frac{\sin^2\theta[1 - \cos^2\theta]}{\cos^2\theta}$$

$$= \sin^2\theta \cdot \frac{\sin^2\theta}{\cos^2\theta}$$

$$= \sin^2\theta \cdot \tan^2\theta$$

$$4\sqrt{mn} = 4\sqrt{\sin^2\theta \cdot \tan^2\theta}$$

$$= 4 \sin\theta \cdot \tan\theta$$

$$4\sqrt{mn} = m^2 - n^2 \quad \text{From equation (1)}$$

Or $m^2 - n^2 = 4\sqrt{mn}$

Hence proved.



Exercise - 1

Prove the following identities:-

1. $\frac{1}{\sec\theta - 1} - \frac{1}{\sec\theta + 1} = 2\cot^2\theta$

2. $\sec^2\theta + \operatorname{cosec}^2\theta = \sec^2\theta \cdot \operatorname{cosec}^2\theta$

3. $\sin^4A + \cos^4A = 1 - 2\sin^2A \cdot \cos^2A$

4. $\sqrt{\frac{1 - \cos\theta}{1 + \cos\theta}} = \operatorname{cosec}\theta - \cot\theta$

5. $(1 + \cot\theta - \operatorname{cosec}\theta)(1 + \tan\theta + \sec\theta) = 2$



6. $\frac{1 + \cos \theta}{1 - \cos \theta} - \frac{1 - \cos \theta}{1 + \cos \theta} = 4 \cot \theta \operatorname{cosec} \theta$
7. $\frac{\sin \theta}{1 + \cos \theta} + \frac{1 + \cos \theta}{\sin \theta} = 2 \operatorname{cosec} \theta$
8. If $\cos \theta - \sin \theta = \sqrt{2} \sin \theta$ then prove that $\cos \theta + \sin \theta = \sqrt{2} \cos \theta$
9. If $\tan \theta = n \tan \phi$ and $\sin \theta = m \sin \phi$ then prove that $\cos^2 \theta = \frac{m^2 - 1}{n^2 - 1}$
10. If $x = a \operatorname{cosec} \theta$ तथा $y = b \cot \theta$ then prove that $\frac{x^2}{a^2} - \frac{y^2}{b^2} = 1$
11. If $x = r \sin A \cos C$, $y = r \sin A \sin C$ and $z = r \cos A$ then prove that

$$r^2 = x^2 + y^2 + z^2$$

Trigonometric equations and identities

We learned the relations among various trigonometric ratios like $\sin \theta$, $\cos \theta$, $\tan \theta$, $\sec \theta$, $\operatorname{cosec} \theta$, $\cot \theta$. Among these we saw one relation $\sin^2 \theta + \cos^2 \theta = 1$ which is true for all values of θ . Such relations between different trigonometric ratios which are true for all values taken by the angle are known as trigonometric identities.

Is the relation $\sin \theta + \cos \theta = 1$ a trigonometric identity?

Let us see.

$$\begin{aligned} &\text{At } \theta = 0^\circ \\ &= \sin 0^\circ + \cos 0^\circ \\ &= 0 + 1 \\ &= 1 \\ &\text{At } \theta = 30^\circ \\ &= \sin 30^\circ + \cos 30^\circ \\ &= \frac{1}{2} + \frac{\sqrt{3}}{2} \\ &= \frac{\sqrt{3} + 1}{2} \\ &\neq 1 \end{aligned}$$



We find that the relation is true for $\theta = 0^\circ$ but not for $\theta = 30^\circ$. Therefore, $\sin\theta + \cos\theta = 1$ cannot be called an identity.

Some trigonometric relations are true for certain values of angles given in the form of variables. These are known as trigonometric equations. Can we say that $\sin\theta + \cos\theta = 1$ is a trigonometric equation? We saw that the relation $\sin\theta + \cos\theta = 1$ is true for $\theta = 0^\circ$ but not for $\theta = 30^\circ$. Therefore, $\sin\theta + \cos\theta = 1$ is a trigonometric equation.

Try These

Put $\theta = 0^\circ, 30^\circ, 45^\circ, 60^\circ, 90^\circ$ in the given relations and check which value of θ satisfies these relations.

1. $\cos\theta + \sin\theta = \sqrt{2}$

2. $\tan^2\theta + \cot^2\theta = 2$

3. $2 \cos^2\theta = 3 \sin\theta$

4. $\tan\theta \cdot \sec\theta = 2\sqrt{3}$



The values of θ for which the equations are true or valid are called solutions of the trigonometric equation.

Let us solve the following trigonometric equations:-

Example-9. Solve $\sqrt{3} \tan\theta - 2 \sin\theta = 0$

Solution : $\sqrt{3} \frac{\sin\theta}{\cos\theta} - 2 \sin\theta = 0$

$$\left[\because \tan\theta = \frac{\sin\theta}{\cos\theta} \right]$$

$$\sqrt{3} \sin\theta - 2 \sin\theta \cdot \cos\theta = 0$$

$$\sin\theta (\sqrt{3} - 2 \cos\theta) = 0$$

$$\sin\theta = 0$$

$$\theta = 0^\circ$$

$$\text{Now, } \sqrt{3} - 2 \cos\theta = 0$$

$$\Rightarrow -2 \cos\theta = -\sqrt{3}$$

$$\Rightarrow \cos\theta = \frac{\sqrt{3}}{2}$$

$$\theta = 30^\circ$$

$$\therefore \theta = 0^\circ, 30^\circ$$



Example-10. Solve $\cos^2 x + \cos x = \sin^2 x$, where $0^\circ \leq x \leq 90^\circ$

Solution :

$$\begin{aligned} \cos^2 x + \cos x &= \sin^2 x \\ \Rightarrow \cos^2 x + \cos x &= 1 - \cos^2 x \\ \Rightarrow \cos^2 x + \cos^2 x + \cos x - 1 &= 0 \\ \Rightarrow 2 \cos^2 x + \cos x - 1 &= 0 \\ \Rightarrow 2 \cos^2 x + 2 \cos x - \cos x - 1 &= 0 \\ \Rightarrow 2 \cos x (\cos x + 1) - 1 (\cos x + 1) &= 0 \\ \Rightarrow (2 \cos x - 1) (\cos x + 1) &= 0 \\ 2 \cos x - 1 &= 0 \\ \cos x &= \frac{1}{2} \\ x &= 60^\circ \end{aligned}$$

Also, $(\cos x + 1) = 0$

$$\begin{aligned} \Rightarrow \cos x + 1 &= 0 \\ \cos x &= -1 \end{aligned}$$

Since $\cos x$ cannot be negative where $0 \leq x \leq 90^\circ$, therefore we will ignore $\cos x = -1$. Hence, the solution for given equation is $x=60^\circ$.



Example-11. Solve the given trigonometric equation where $0^\circ \leq \theta \leq 90^\circ$

$$\frac{\cos \theta}{\operatorname{cosec} \theta + 1} + \frac{\cos \theta}{\operatorname{cosec} \theta - 1} = 2$$

Solution :

$$\begin{aligned} \frac{\cos \theta}{\operatorname{cosec} \theta + 1} + \frac{\cos \theta}{\operatorname{cosec} \theta - 1} &= 2 \\ \Rightarrow \frac{\cos \theta (\operatorname{cosec} \theta - 1) + \cos \theta (\operatorname{cosec} \theta + 1)}{\operatorname{cosec}^2 \theta - 1} &= 2 \\ \Rightarrow \frac{\cos \theta [\operatorname{cosec} \theta - 1 + \operatorname{cosec} \theta + 1]}{\cot^2 \theta} &= 2 \quad [\because \operatorname{cosec}^2 \theta - 1 = \cot^2 \theta] \\ \Rightarrow \frac{\cos \theta \cdot 2 \operatorname{cosec} \theta}{\cot^2 \theta} &= 2 \\ \Rightarrow \frac{\cos \theta \cdot 2 \cdot \frac{1}{\sin \theta}}{\cot^2 \theta} &= 2 \end{aligned}$$

$$\begin{aligned} \Rightarrow \quad & 2 \frac{\cos \theta}{\sin \theta} = 2 \\ \Rightarrow \quad & \frac{2 \cot \theta}{\cot^2 \theta} = 2 \\ \Rightarrow \quad & \frac{2}{\cot \theta} = 2 \\ \Rightarrow \quad & 2 \tan \theta = 2 \\ \Rightarrow \quad & \tan \theta = 1 \\ \Rightarrow \quad & \tan \theta = \tan 45^\circ \\ \therefore \quad & \theta = 45^\circ \end{aligned}$$



Exercise - 2

1. Solve the follow trigonometric equation where $0^\circ \leq \theta \leq 90^\circ$

(i) $2 \cos^2 \theta - \sqrt{3} \cos \theta = 0$

(ii) $2 \sin^2 \theta - \cos \theta = 1$

(iii) $3 \tan^2 \theta = 2 \sec^2 \theta + 1$

(iv) $\cos^2 \theta - 3 \cos \theta + 2 = \sin^2 \theta$

(v) $\frac{\cos \theta}{1 - \sin \theta} + \frac{\cos \theta}{1 + \sin \theta} = 4$



Trigonometric Ratios of Complementary Angles

In right angle triangle $\triangle ABC$ if $\angle A = 30^\circ$ then what will be the value of $\angle C$ (figure-3)? And is it possible to find the value of $\angle A$ if we know that $\angle C = 60^\circ$ (figure-4)?

Is there a relation between $\angle A$ and $\angle C$ so that if we know the value of one angle we can find the value of the other angle?

We know that in $\triangle ABC$,

$$\angle A + \angle B + \angle C = 180^\circ$$

$$\therefore \angle B = 90^\circ$$

$$\therefore \angle A + \angle C = 90^\circ$$

This means that $\angle A$ and $\angle C$ are complementary angles.

Now, in triangle ABC (figure-5)

If $\angle A = \theta$ then $\angle C = 90^\circ - \theta$

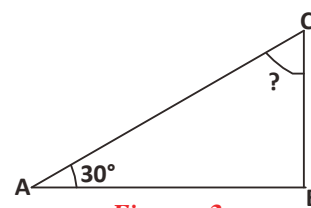

Figure - 3

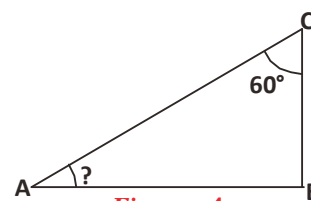

Figure - 4

Then, is there any relation between the trigonometric ratios of $\angle A$ and $\angle C$?

Is it possible in the given triangle to convert the trigonometric ratios of angle $(90^\circ - \theta)$ into trigonometric ratios of angle θ ? How?

$$\sin \theta = \frac{BC}{AC} \quad \cos \theta = \frac{AB}{AC} \quad \tan \theta = \frac{BC}{AB}$$

$$\operatorname{cosec} \theta = \frac{AC}{BC} \quad \sec \theta = \frac{AC}{AB} \quad \cot \theta = \frac{AB}{AC}$$

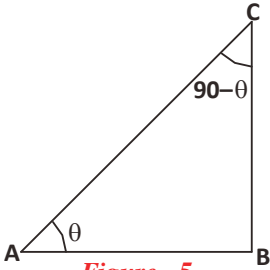

Figure - 5

If angle $\angle C = 90^\circ - \theta$ in $\triangle ABC$, then

Trigonometric ratios are:-

$$\sin(90^\circ - \theta) = \frac{AB}{AC}, \quad \cos(90^\circ - \theta) = \frac{BC}{AC}, \quad \tan(90^\circ - \theta) = \frac{AB}{BC},$$

$$\operatorname{cosec}(90^\circ - \theta) = \frac{AC}{AB}, \quad \sec(90^\circ - \theta) = \frac{AC}{BC}, \quad \cot(90^\circ - \theta) = \frac{BC}{AB}$$

When we compare the trigonometric ratios for angles θ and $(90^\circ - \theta)$ we get the following relations:-

$$\sin(90^\circ - \theta) = \frac{AB}{AC} = \cos \theta, \quad \cos(90^\circ - \theta) = \frac{BC}{AC} = \sin \theta$$

$$\tan(90^\circ - \theta) = \cot \theta \text{ and } \cot(90^\circ - \theta) = \tan \theta$$

$$\sec(90^\circ - \theta) = \operatorname{cosec} \theta \text{ और } \operatorname{cosec}(90^\circ - \theta) = \sec \theta$$



Think and Discuss

Is the above relation true for all values θ where $0^\circ \leq \theta \leq 90^\circ$.

Try These



Complete the following table by using the relations between trigonometric ratios of complementary angles

θ	0°	30°	45°	60°	90°
$\sin \theta$	0	$\frac{1}{\sqrt{2}}$	1
$\cos \theta$	$\frac{\sqrt{3}}{2}$	$\frac{1}{2}$

Applications of Trigonometric Ratios of Complementary Angles

Let us see how to find values using trigonometric ratios of complementary angles without using the trigonometric table. Can we use them to find trigonometric ratios of non-simple angles, for example, $\theta=31^\circ$ or $\phi = 20^\circ$ or 43° ?

Now we will try to find the value of $\frac{2 \sin 30^\circ}{\cos 60^\circ}$ without using the trigonometric table.

$$\begin{aligned} & \frac{2 \sin 30^\circ}{\cos 60^\circ} \\ = & \frac{2 \sin 30^\circ}{\cos(90^\circ - 30^\circ)} && [\because \cos(90^\circ - \theta) = \sin \theta] \\ = & 2 \frac{\sin 30^\circ}{\sin 30^\circ} \\ = & 2 \end{aligned}$$

Similarly, if we have to find out the value of $\frac{3 \tan 15^\circ}{\cot 75^\circ}$

$$\begin{aligned} & \frac{3 \tan 15^\circ}{\cot 75^\circ} \\ = & \frac{3 \tan 15^\circ}{\cot(90^\circ - 15^\circ)} \\ = & \frac{3 \tan 15^\circ}{\tan 15^\circ} \\ = & 3 \end{aligned}$$

Let's try to understand through examples.

Example-12. Find the value of the following:-

$$(a) \frac{\sin 31^\circ}{2 \cos 59^\circ} \qquad (b) \frac{\sec 70^\circ}{\operatorname{cosec} 20^\circ} + \frac{\sin 59^\circ}{\cos 31^\circ}$$

Solution : (a) $\frac{\sin 31^\circ}{2 \cos 59^\circ}$



$$\begin{aligned}
 &= \frac{\sin(90^\circ - 59^\circ)}{2 \cos 59^\circ} \\
 &= \frac{\cos 59^\circ}{2 \cos 59^\circ} \quad [\because \sin(90^\circ - \theta) = \cos \theta] \\
 &= \frac{1}{2}
 \end{aligned}$$

$$\begin{aligned}
 \text{(b)} \quad &\frac{\sec 70^\circ}{\operatorname{cosec} 20^\circ} + \frac{\sin 59^\circ}{\cos 31^\circ} \\
 &= \frac{\sec(90^\circ - 20^\circ)}{\operatorname{cosec} 20^\circ} + \frac{\sin(90^\circ - 31^\circ)}{\cos 31^\circ} \quad \left[\begin{array}{l} \because \sec(90^\circ - \theta) = \operatorname{cosec} \theta \\ \sin(90^\circ - \theta) = \cos \theta \end{array} \right] \\
 &= \frac{\operatorname{cosec} 70^\circ}{\operatorname{cosec} 70^\circ} + \frac{\cos 31^\circ}{\cos 31^\circ} \\
 &= 1 + 1 \\
 &= 2
 \end{aligned}$$

Example-13. Find the value of $\left(\frac{\sin 47^\circ}{\cos 43^\circ}\right)^2 + \left(\frac{\cos 43^\circ}{\sin 47^\circ}\right)^2 - 4 \cos^2 45^\circ$.

Solution :

$$\begin{aligned}
 &\left(\frac{\sin 47^\circ}{\cos 43^\circ}\right)^2 + \left(\frac{\cos 43^\circ}{\sin 47^\circ}\right)^2 - 4 \cos^2 45^\circ \\
 &= \left(\frac{\sin(90^\circ - 43^\circ)}{\cos 43^\circ}\right)^2 + \left(\frac{\cos(90^\circ - 47^\circ)}{\sin 47^\circ}\right)^2 - 4 \left(\frac{1}{\sqrt{2}}\right)^2 \\
 &= \left(\frac{\cos 43^\circ}{\cos 43^\circ}\right)^2 + \left(\frac{\sin 47^\circ}{\sin 47^\circ}\right)^2 - 4 \times \frac{1}{2} \\
 &= 1 + 1 - 2 \\
 &= 0
 \end{aligned}$$

Example-14. Prove that-

$$\tan 7^\circ \tan 23^\circ \tan 60^\circ \tan 67^\circ \tan 83^\circ = \sqrt{3}$$

Solution :

$$\begin{aligned} \text{L.H.S.} &= \tan 7^\circ \tan 23^\circ \tan 60^\circ \tan 67^\circ \tan 83^\circ \\ &= \tan (90^\circ - 83^\circ) \tan (90^\circ - 67^\circ) \tan 60^\circ \tan 67^\circ \tan 83^\circ \\ &= \cot 83^\circ \cot 67^\circ \tan 60^\circ \tan 67^\circ \tan 83^\circ \\ &= \cot 83^\circ \tan 83^\circ \cot 67^\circ \tan 67^\circ \tan 60^\circ \\ &= \cot 83^\circ \times \frac{1}{\cot 83^\circ} \times \cot 67^\circ \times \frac{1}{\cot 67^\circ} \times \sqrt{3} \\ &= \sqrt{3} \end{aligned}$$

Solving trigonometric equations

Let us consider the given equation:

$$\cos(90^\circ - \theta) = \frac{1}{2}$$

If we have to identify the value of the unknown θ , what should we do?

$$\begin{aligned} \cos(90^\circ - \theta) &= \frac{1}{2} \\ \Rightarrow \sin \theta &= \sin 30^\circ \\ \theta &= 30^\circ \end{aligned}$$

Let us understand through some more examples.

Example-15. If $\sin 55^\circ \operatorname{cosec}(90^\circ - \theta) = 1$, then find the value of θ where

$$0^\circ \leq \theta \leq 90^\circ$$

Solution :

$$\begin{aligned} \sin 55^\circ \operatorname{cosec}(90^\circ - \theta) &= 1 \\ \Rightarrow \sin(90^\circ - 35^\circ) \sec \theta &= 1 \\ \Rightarrow \cos 35^\circ \cdot \sec \theta &= 1 \\ \Rightarrow \sec \theta &= \frac{1}{\cos 35^\circ} \\ \Rightarrow \sec \theta &= \sec 35^\circ \\ \therefore \theta &= 35^\circ \end{aligned}$$



Example-16. If $\sin 34^\circ = p$ then find the value of $\cot 56^\circ$.

Solution : $\sin 34^\circ = p$

$$\sin (90^\circ - 56^\circ) = p$$

$$\cos 56^\circ = p \quad \dots(1)$$

We know that $\sin^2 \theta + \cos^2 \theta = 1$

$$\Rightarrow \sin^2 \theta = 1 - \cos^2 \theta$$

$$\Rightarrow \sin^2 56^\circ = 1 - \cos^2 56^\circ$$

$$\Rightarrow \sin^2 56^\circ = 1 - p^2 \quad \dots(2)$$

$$\Rightarrow \sin 56^\circ = \sqrt{1 - p^2}$$

With the help of equations (1) & (2)

$$\cot 56^\circ = \frac{\cos 56^\circ}{\sin 56^\circ}$$

$$= \frac{p}{\sqrt{1 - p^2}}$$

Example-17. If $\cot 3A = \tan (A - 22^\circ)$ where $3A$ is an acute angle, then find the value of A .

Solution : Given that- $\cot 3A = \tan (A - 22^\circ)$

$$\Rightarrow \tan (90^\circ - 3A) = \tan (A - 22^\circ)$$

$$\Rightarrow 90^\circ - 3A = A - 22^\circ$$

$$\Rightarrow 90^\circ + 22^\circ = A + 3A$$

$$\Rightarrow 112^\circ = 4A$$

$$\Rightarrow A = \frac{112^\circ}{4}$$

$$\therefore A = 28^\circ$$

With the help of the trigonometric ratios of complementary angles, it is possible to prove relations between trigonometric ratios. Let us see:-

Example-18. Prove that- $\frac{\sin(90^\circ - \theta) \cos(90^\circ - \theta)}{\tan \theta} = \cos^2 \theta$

Solution : L.H.S. = $\frac{\sin(90^\circ - \theta) \cos(90^\circ - \theta)}{\tan \theta}$

$$\begin{aligned}
 &= \frac{\cos \theta \sin \theta}{\tan \theta} \\
 &= \frac{\cos \theta \sin \theta}{\frac{\sin \theta}{\cos \theta}} \\
 &= \frac{\cos^2 \theta \sin \theta}{\sin \theta} \\
 &= \cos^2 \theta \\
 &= \text{R.H.S.}
 \end{aligned}$$



Example-19. Prove that- $\sin(90^\circ - \theta) \sec \theta + \cos(90^\circ - \theta) \operatorname{cosec} \theta = 2$

Solution : L.H.S. $= \sin(90^\circ - \theta) \sec \theta + \cos(90^\circ - \theta) \operatorname{cosec} \theta$

$$\begin{aligned}
 &= \cos \theta \sec \theta + \sin \theta \operatorname{cosec} \theta \\
 &= \cos \theta \times \frac{1}{\cos \theta} + \sin \theta \times \frac{1}{\sin \theta} \\
 &= 1 + 1 \\
 &= 2 \\
 &= \text{R.H.S.}
 \end{aligned}$$

Example-20. If $\angle A, \angle B$ and $\angle C$ are the interior angle of $\triangle ABC$, then prove that-

$$\sin\left(\frac{A+B}{2}\right) = \cos \frac{C}{2}$$

Solution : Given that- A, B and C are the interior angle of $\triangle ABC$

Then, $A + B + C = 180^\circ$

$$A + B = 180^\circ - C \quad \dots(1)$$

Again, L.H.S. $= \sin\left(\frac{A+B}{2}\right)$

$$\begin{aligned}
 &= \sin\left(\frac{180^\circ - C}{2}\right) \\
 &= \sin\left(\frac{180^\circ}{2} - \frac{C}{2}\right)
 \end{aligned}$$



$$\begin{aligned}
 &= \sin \left(90^\circ - \frac{C}{2} \right) \\
 &= \cos \frac{C}{2} \\
 &= \text{R.H.S.}
 \end{aligned}$$

Now, we will learn how to convert trigonometric ratio of a given angle to a trigonometric ratio of an angle which lies between 0° and 45° .

Example-21. Express $\tan 59^\circ + \cot 75^\circ$ as trigonometric ratios of angles between 0° and 45° .

Solution :

$$\begin{aligned}
 \tan 59^\circ + \cot 75^\circ &= \tan (90^\circ - 31^\circ) + \cot (90^\circ - 15^\circ) \\
 &= \cot 31^\circ + \tan 15^\circ
 \end{aligned}$$

$$[\because \tan (90^\circ - \theta) = \cot \theta]$$

$$\cot (90^\circ - \theta) = \tan \theta]$$

Exercise-3



1. Express the following as trigonometric ratios of angles which lie between 0° and 45° .

(i) $\sin 56^\circ$ (ii) $\tan 81^\circ$ (iii) $\sec 73^\circ$

2. Find the value of the following:-

(i) $\frac{\cos 80^\circ}{\sin 10^\circ}$ (ii) $\frac{\sin 37^\circ}{2 \cos 53^\circ}$ (iii) $3 \sin 17^\circ \sec 73^\circ$

3. Find the value of the following:-

(i) $\sin 64^\circ - \cos 26^\circ$
 (ii) $3 \cos 80^\circ \operatorname{cosec} 10^\circ + 2 \cos 59^\circ \operatorname{cosec} 31^\circ$

(iii) $2 \frac{\cos 67^\circ}{\sin 23^\circ} - \frac{\tan 40^\circ}{\cot 50^\circ} + \cos 0^\circ$

(iv) $\sin^2 35^\circ + \sin^2 55^\circ$

(v) $\left(\frac{5 \sin 35^\circ}{\cos 55^\circ} \right) + \left(\frac{\cos 55^\circ}{2 \sin 35^\circ} \right) - 2 \cos 60^\circ$

4. Prove that-

(i) $\sin 63^\circ \cos 27^\circ + \cos 63^\circ \sin 27^\circ = 1$

(ii) $\tan 15^\circ \tan 36^\circ \tan 45^\circ \tan 54^\circ \tan 75^\circ = 1$

(iii) $\sin^2 85^\circ + \sin^2 80^\circ + \sin^2 10^\circ + \sin^2 5^\circ = 2$

5. Prove that-

$$\sin(90^\circ - \theta) \cos(90^\circ - \theta) = \frac{\tan \theta}{1 + \cot^2(90^\circ - \theta)}$$

6. Prove that-

$$\frac{\cos \theta}{\sec(90^\circ - \theta) + 1} + \frac{\sin(90^\circ - \theta)}{\operatorname{cosec} \theta - 1} = 2 \cot(90^\circ - \theta)$$

7. Prove that-

$$\frac{\tan(90^\circ - \theta)}{\operatorname{cosec}^2 \theta \cdot \tan \theta} = \cos^2 \theta$$

8. If $\sin A = \cos B$ then prove that $A + B = 90^\circ$

9. If $\operatorname{cosec} 2A = \sec(A - 36^\circ)$, where $2A$ is an acute angle, then find the value of A .

10. If $A + B = 90^\circ$, $\sec A = a$, $\cot B = b$ then prove that $a^2 - b^2 = 1$

11. If A , B and C are interior angle of a triangle ABC , then prove that-

$$\tan\left(\frac{B + C}{2}\right) = \cot\left(\frac{A}{2}\right)$$

12. If $\sec 34^\circ = x$ then find the value of $\cot^2 56^\circ + \operatorname{cosec} 56^\circ$.

What We Have Learnt

1. The following relations are observed between trigonometric ratios:

$$\sin^2 \theta + \cos^2 \theta = 1 \quad \text{where } 0^\circ \leq \theta \leq 90^\circ$$

$$1 + \tan^2 \theta = \sec^2 \theta \quad \text{where } 0^\circ \leq \theta < 90^\circ$$

$$1 + \cot^2 \theta = \operatorname{cosec}^2 \theta \quad \text{where } 0^\circ < \theta \leq 90^\circ$$

2. Any trigonometric ratio can be written in terms of any other trigonometric ratio.

3. Identities are those trigonometric equations that are true for all values of the angles.

4. For a value of angle θ , if one trigonometric ratio is known then the other trigonometric ratios can be found.



5. The following relations are seen between trigonometric ratios of complementary angles:

$$\sin(90^\circ - \theta) = \cos\theta \quad , \quad \cos(90^\circ - \theta) = \sin\theta$$

$$\tan(90^\circ - \theta) = \cot\theta \quad , \quad \cot(90^\circ - \theta) = \tan\theta$$

$$\sec(90^\circ - \theta) = \operatorname{cosec}\theta \quad , \quad \operatorname{cosec}(90^\circ - \theta) = \sec\theta$$

6. Identities can't be proved or verified using only a few values of angle, they have to be true for all values.

ANSWER KEY

Exercise - 2

1(i). $\theta = 30^\circ, 90^\circ$

1(iv). $\theta = 0, 60^\circ$

1(ii). $\theta = 60^\circ$

1(v). $\theta = 60^\circ$

1(iii). $\theta = 60^\circ$

Exercise - 3

1. (i) $\cos 34^\circ$

(ii) $\cot 9^\circ$

(iii) $\operatorname{cosec} 17^\circ$

2. (i) 1

(ii) $\frac{1}{2}$

(iii) 3

3. (i) 0

(ii) 5

(iii) 2

(iv) 1

(v) $\frac{9}{2}$

9. 42°

12. $x^2 + x - 1$



HEIGHT AND DISTANCE

CHAPTER

10

Suppose you want to find out the length and breadth of the playground in your school. How will you measure it? You will have to use a measuring instrument like a scale (ruler) or a measuring tape. Can you use a ruler to easily measure the length of the playground? What difficulties will you face?

Rajesh said – If I use a small ruler then it will take a long time to measure the field because it is very long. I'll have to lift and place the ruler again and again and this can introduce errors in measurement. So, I should use a long measuring tape instead.

Zahida said – To find out the length and breadth of the field, I will have to take the measuring tape from one end to the other. At one corner of the field, one student should stand holding one end of the tape. Another student should take the measuring tape to the second corner and note the reading. This will give us the length of the field.

Jamuna asked – Can we use this method to find out the height of a palm (*Khajur*) tree or the height of volleyball poles? We will have to find the distance between the ground and the top of the tree (or pole) which is difficult. How will we reach the top? Who will climb to the top of the tree?

Aslam – Then what should we do?

Can we use any mathematical technique in these situations?

Can we use trigonometry to find out heights and distances?

Let us see –

Suppose your school has a flagstaff (pole) and you want to find its height. We know that trigonometric ratios are relations between the sides and angles of a triangle. Can you visualize a right angled triangle where the flagstaff is one side of the triangle? What values should we know if we want to find the height of the pole?

Imagine that the pole is one side BC of a right angled triangle. C is the top of the pole and B is the other end. Take any point A on the playground which is 10 m away from B (*figure-2*). Suppose that the line joining A to the top of the pole C forms an angle of 60° with the ground.

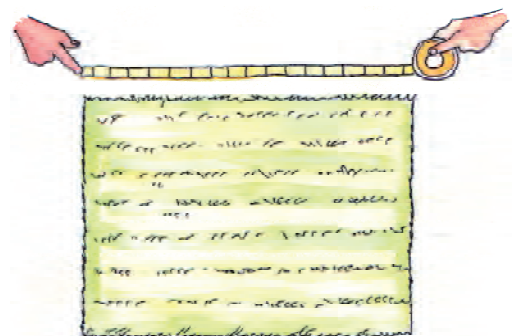

Figure - 1

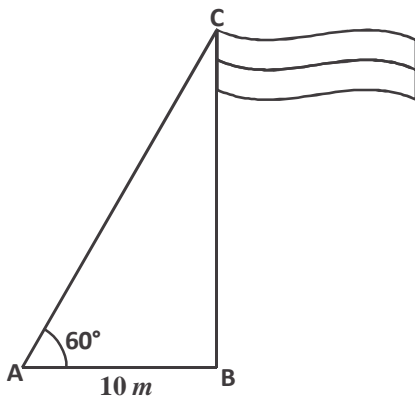

Figure - 2

Then in $\triangle ABC$

$$\angle CAB = 60^\circ$$

$$AB = 10 \text{ meter}$$

$$\tan A = \frac{BC}{AB}$$

$$\tan 60^\circ = \frac{BC}{10}$$

$$BC = 10 \tan 60^\circ$$

$$BC = 10\sqrt{3} \text{ meter}$$

In this way, we can find out the height of the flagstaff using trigonometry.

Angle of Elevation

Let us again examine *figure-2*. Suppose we stand in the field and look at the top of the flag. The line AC drawn from our eye at point A to the point C on the top of the flagpole is called the *line of sight*.

If the height of the pole is more than our height then we have to look upwards to see the top of the pole.

The angle formed between the line of sight AC and the horizontal AB is called the angle of elevation (*figure-3*). Here, we have supposed that our eye is at the point A . Thus, the angle of elevation is the angle between the line of sight

and the horizontal line at point A .

If the height of pole is more then we will have to raise our heads even more to see its top-most point.

In this situation will the angle of elevation be more or less? That is, will the value of ϕ be more than θ .

The angle of elevation increases when the height of the pole is increased that is the angle between the horizon and line of sight increases (*figure-4*).

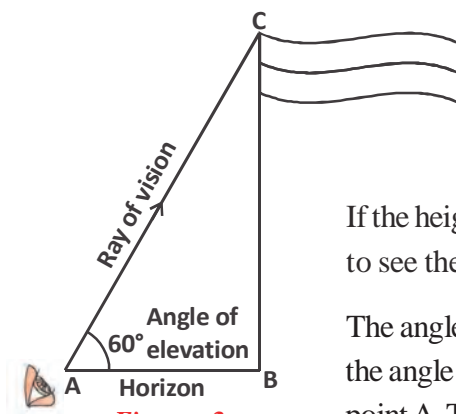

Figure - 3

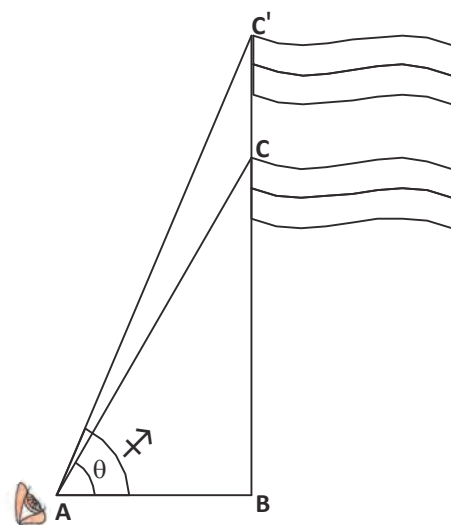

Figure - 4

Think and Discuss

How will the angle of elevation be affected if the height of pole is decreased?

Let us consider another situation where we are looking at the top of the pole not from point A but from the point A' which is farther away from the foot of the pole (figure-5).

We find that if we look at the top of the pole from the point A' then the angle between the line of sight and the horizon decreases that is the value of the angle of elevation becomes less.

Thus, we observe that the angle of elevation increases with increase in the height of the object but decreases with increase in distance between the observer and the object.

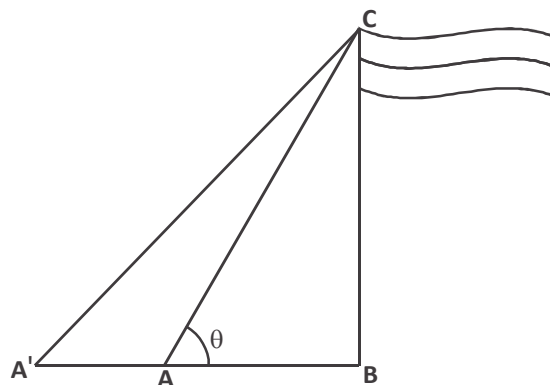

Figure - 5

We can find the height of mountains, distance between planets, depth of oceans, distance between the earth and sun using trigonometry. Astronomers have used it to calculate distances from the Earth to the planets and stars.

We use trigonometry to solve problems in our daily life as well. Let us see some examples.

Example-1. From a point on the ground, which is 15 m away from the foot of a building, the angle of elevation of the top of the building is found to be 45° . Find the height of the building.

Solution : In the figure, AB is the height of the building. From a point C on the ground, which is 15 m away from the foot B of the building the angle of elevation of the top A of the building, $\angle ACB = 45^\circ$

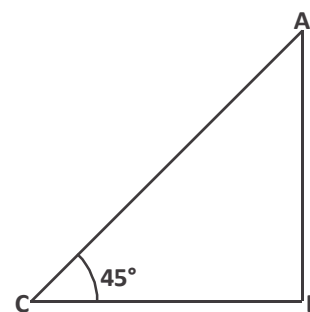

Figure - 6

Let the height of the building be h .

$$\text{Then, } \tan 45^\circ = \frac{AB}{BC} \text{ in } \triangle ABC$$

$$\text{Or } \tan 45^\circ = \frac{h}{15}$$

$$\text{Or } 1 = \frac{h}{15} \quad [\because \tan 45^\circ = 1]$$

$$\therefore h = 15 \text{ meter}$$

Therefore, height of the building is 15 m.

Example-2. A ladder is placed against a vertical wall so that it forms an angle of 60° with the ground. If the foot of the ladder is 4 meters away from the base of the wall then find the length of the ladder.

Solution : Let AC be the ladder which is x meters long, i.e. $AC = x$ m. It is given that the foot of the ladder, A is 4 meters away from the wall.

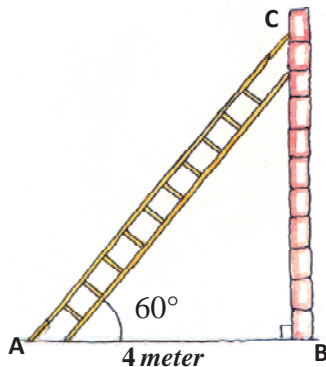

Figure - 7

Thus, in $\triangle ABC$ $AB = 4$ m

And $\angle BAC = 60^\circ$

Then $\cos 60^\circ = \frac{AB}{AC}$

$$\text{Or } \frac{1}{2} = \frac{4}{x}$$

$$\text{Or } x = 8 \text{ meter}$$

Thus, the length of the ladder is 8 meters.

Example-3. A tree breaks due to storm and the broken part bends so that the top of the tree touches the ground making an angle 60° with it. The distance between the foot of the tree to the point where the top touches the ground is 6 m. Find the height of the tree.

Solution : Let AC be the broken part of the tree (figure-8).

It is given that the distance between the foot of the tree to the point where the top touches the ground is 6 m.

Thus, in right triangle $\triangle ABC$

$$\tan 60^\circ = \frac{BC}{AB}$$

$$\sqrt{3} = \frac{BC}{6}$$

$$BC = 6\sqrt{3} \text{ m}$$

Again, in right triangle $\triangle ABC$

$$\sin 60^\circ = \frac{BC}{AC}$$

$$\text{Or } \frac{\sqrt{3}}{2} = \frac{6\sqrt{3}}{AC}$$

$$\text{Or } AC = \frac{6\sqrt{3} \times 2}{\sqrt{3}}$$

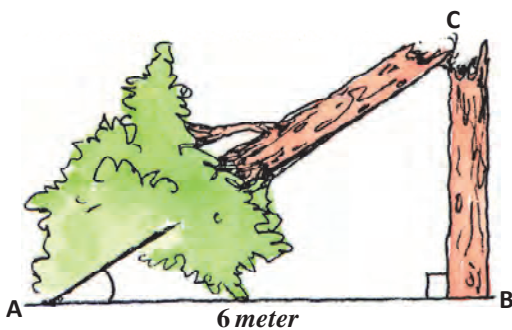

Figure - 8

$$AC = 12 \text{ m}$$

$$\begin{aligned} \text{Thus, height of the tree} &= BC + AC \\ &= 6\sqrt{3} + 12 \\ &= 6(\sqrt{3} + 2) \text{ m} \end{aligned}$$

Example-4. An observer 1.4 m tall is 25.6 m away from a tower. The angle of elevation of the top of the tower from her eyes is 45° . What is the height of the tower?

Solution : Here, BC is the tower, AE the observer and $\angle CED$ is the angle of elevation.

$$\text{And } AB = ED = 25.6 \text{ m}$$

$$AE = BD = 1.4 \text{ m}$$

In right-angle triangle $\triangle CDE$

$$\tan 45^\circ = \frac{DC}{ED}$$

$$1 = \frac{DC}{25.6}$$

$$DC = 25.6 \text{ मी.}$$

$$\begin{aligned} \text{Thus, height of tower} &= BD + DC \\ &= 1.4 + 25.6 \\ &= 27 \text{ मी.} \end{aligned}$$

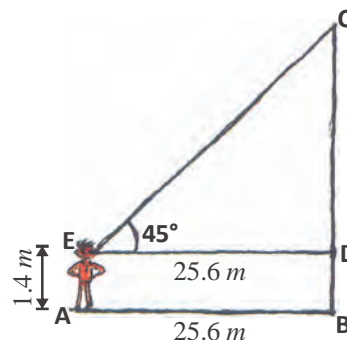

Figure - 9

Note:- If height of the observer is not given then the observer is assumed to be a point.

There is a flag in front of Farida's house (Figure-10). She wants to know the height of the flag. Can we find the height without taking the pole out of the ground?

Let us see-

Example-5. From a point, P on the ground the angle of elevation of a building is 30° . A flag is placed on the top of the building and the angle of elevation from point P to the flag is 45° . Find the height of the flagstaff and the distance between P and the building.

Solution : In figure-10, AB is the height of the building, BD is the length of the flagstaff and P is the observation point. Notice, that here we have two right angle triangles, $\triangle PAB$ and $\triangle PAD$. We have to find the length of the flagstaff and the distance between P and the building.

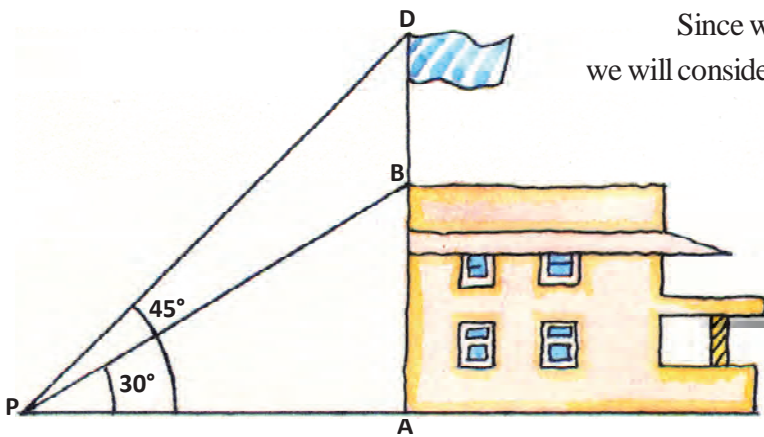

Figure - 10

Since we know the height AB of the building, first we will consider right angle triangle ΔPAB .

$$\text{Here, } \tan 30^\circ = \frac{AB}{PA}$$

$$\text{That is, } \frac{1}{\sqrt{3}} = \frac{10}{PA}$$

$$\text{Therefore, } PA = 10\sqrt{3} \text{ m}$$

\therefore Distance between P and the building is $10\sqrt{3} \text{ m}$

Now, let us suppose that $BD = x \text{ meter}$

$$\text{And } AD = AB + BD = (10 + x) \text{ m}$$

Then in right triangle ΔPAD

$$\tan 45^\circ = \frac{AD}{PA}$$

$$= \frac{10 + x}{10\sqrt{3}}$$

$$\Rightarrow 1 = \frac{10 + x}{10\sqrt{3}}$$

$$\Rightarrow 10\sqrt{3} = 10 + x$$

$$x = 10(\sqrt{3} - 1) \text{ m}$$

Thus, height of the flagpole is $10(\sqrt{3} - 1) \text{ m}$

We have already seen the relation between angle of elevation and height and distance. We saw that value of the angle of elevation increases with increase in the height of the object but decreases with increase in distance between the observer and the object.

We will now solve some examples based on the statement given above.

Example-6. A boy is standing at some distance from a 30 m tall building. The angle of elevation from his eyes to the top of the building increases from 30° to 60° as he walks towards the building. Find the distance he walked towards the building.

Solution : Suppose that BC represents the building and the boy is standing at point A.

$$BC = 30 \text{ m}$$

In right angle $\triangle ABC$

$$\tan 30^\circ = \frac{BC}{AC}$$

$$\frac{1}{\sqrt{3}} = \frac{30}{AC}$$

$$AC = 30\sqrt{3} \text{ m}$$

Again, in right angle $\triangle BCD$

$$\tan 60^\circ = \frac{BC}{CD}$$

$$\tan 60^\circ = \frac{30}{CD}$$

$$\sqrt{3} = \frac{30}{CD}$$

$$CD = \frac{30}{\sqrt{3}}$$

$$= \frac{10 \times 3}{\sqrt{3}}$$

$$CD = 10\sqrt{3} \text{ m}$$

Thus, distance walked by the boy towards the building $AD = AC - CD$

$$= 30\sqrt{3} - 10\sqrt{3}$$

$$20\sqrt{3} \text{ m}$$

Thus, the boy walked $20\sqrt{3} \text{ m}$ towards the building.

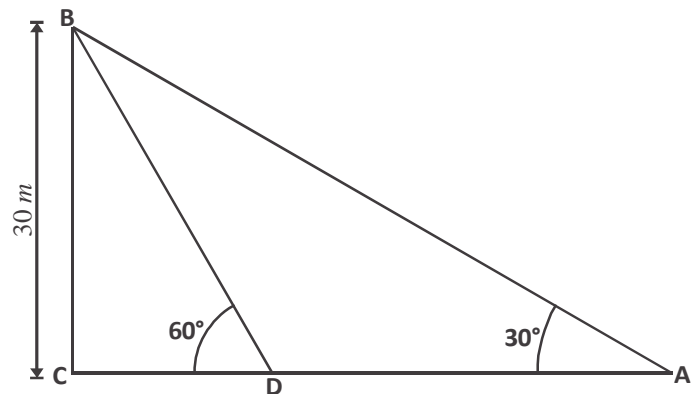

Figure - 11

Angle of Depression

Let us discuss another situation:-

Rama is standing on the balcony of her house watching a car come towards her. The angle so formed by the line of sight with the horizontal is called the angle of depression (figure-12).

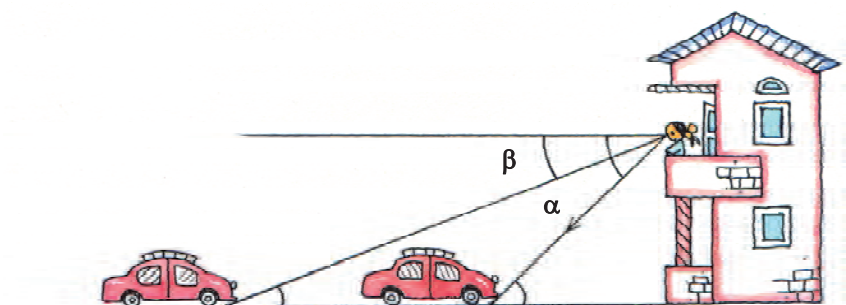

Figure - 12

Now, if the car comes closer to the house (figure-12) then what will be the change in the angle of depression?

What will be the relation between angles α and β ?

Will $\alpha > \beta$

$\alpha < \beta$

Or $\alpha = \beta$

You can see that when the distance between the car and the house decreases the value of the angle of depression increases.

That is, $\alpha > \beta$

Think and Discuss

Suppose the car is right below Rama in figure-12 then what will be the angle of depression?

Example-7. The angle of depression of the top of a tower to a flowerpot on the ground, which is 30 m away from the foot of the tower, is 30° . Find the height of the tower.

Solution : Let AB be the tower and point O be the flowerpot.

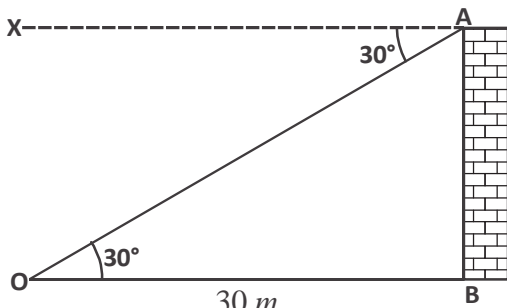

Figure - 13

Angle of depression $\angle XAO = 30^\circ$ and

$$OB = 30 \text{ meter}$$

$$\angle XAO = \angle AOB = 30^\circ$$

(alternate angles)

In triangle ΔOAB

$$\tan 30^\circ = \frac{AB}{OB}$$

$$AB = OB \tan 30^\circ$$

$$= 30 \times \frac{1}{\sqrt{3}}$$

$$= \frac{30}{\sqrt{3}}$$

$$= 10\sqrt{3} \text{ meter}$$

Therefore, height of the tower is $10\sqrt{3}$ meter

Example-8. The angles of depressions from the top of a light pole to the top and foot of a building are 45° and 60° respectively. If the height of the building is 12 m then find the height of the light pole and its distance from the building.

Solution : Let PQ be the light pole. AB is a 12 meter high building which is at a distance of x meters from the light pole.

Thus, $QB = x$ m, $AB = 12$ m

The angles of depressions from the top of a light pole to the top and foot of a building are 45° and 60° respectively.

$\angle APX = 45^\circ$ and $\angle BPX = 60^\circ$ and let $PR = h$

In right angle triangle PRA

$$\tan 45^\circ = \frac{PR}{RA}$$

$$\Rightarrow 1 = \frac{PR}{x}$$

$$\Rightarrow PR = x$$

$$\therefore h = x$$

In right angle triangle ΔPQB

$$\Rightarrow \tan 60^\circ = \frac{PQ}{QB}$$

$$\Rightarrow \sqrt{3} = \frac{h+12}{x}$$

$$\Rightarrow \sqrt{3}x = h + 12$$

On putting the value of x

$$\Rightarrow \sqrt{3}h = h + 12$$

$$\Rightarrow \sqrt{3}h - h = 12$$

$$\Rightarrow h(\sqrt{3} - 1) = 12$$

$$\Rightarrow h = \frac{12}{\sqrt{3} - 1}$$

$$\Rightarrow h = \frac{12}{\sqrt{3} - 1} \times \frac{\sqrt{3} + 1}{\sqrt{3} + 1}$$

(on rationalizing the denominator)

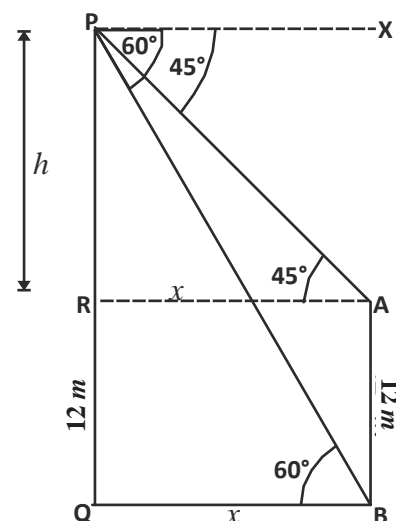

Figure - 14

$$\Rightarrow h = \frac{12(\sqrt{3}+1)}{(\sqrt{3})^2 - 1^2}$$

$$\Rightarrow h = \frac{12(\sqrt{3}+1)}{3-1}$$

$$\Rightarrow h = 6(\sqrt{3}+1) \text{ मी.}$$

Height of light pole = PR + RQ

$$= 6(\sqrt{3}+1)+12$$

$$= 6\sqrt{3}+6+12$$

$$= 6\sqrt{3}+18$$

$$= 6(\sqrt{3}+3)m$$

Since $x = h$ therefore $x = 6(\sqrt{3}+1) m$

The height of the light pole will be $6(\sqrt{3}+3)m$ and distance from the building is $6(\sqrt{3}+1) m$

Example-9. The angles of depression from the peak of a hill to two houses on opposite sides of the hill are 30° and 60° respectively. Find the distance between the houses given that the height of the hill is 60m.

Solution : Let PQ be the hill and A and B be the two houses on opposite sides of the hill.

Given that PQ = 60 m

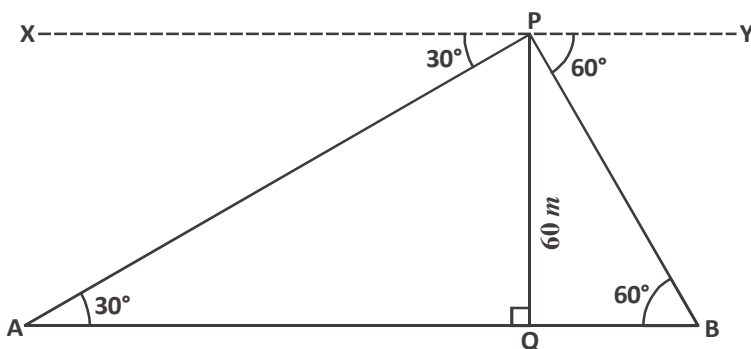

Figure - 15

$$\angle XPA = 30^\circ$$

$$\therefore \angle PAQ = 30^\circ \quad (\text{alternate angles})$$

$$\text{Similarly, } \angle YPB = \angle PBQ = 60^\circ$$

In right angle triangle ΔPQA

$$\tan 30^\circ = \frac{PQ}{AQ}$$

$$\frac{1}{\sqrt{3}} = \frac{60}{AQ}$$

$$AQ = 60\sqrt{3} \text{ m}$$

Again in triangle PQB

$$\tan 60^\circ = \frac{PQ}{BQ}$$

$$\sqrt{3} = \frac{60}{BQ}$$

$$BQ = \frac{60}{\sqrt{3}}$$

$$BQ = 20\sqrt{3} \text{ m}$$

Thus, distance between the two houses $AB = AQ + BQ$

$$= 60\sqrt{3} + 20\sqrt{3}$$

$$AB = 80\sqrt{3} \text{ m}$$

Example-10. A straight road goes straight up till the base of the building. A man standing on the top of the building sees a car at 30° angle of depression. The car is moving towards the building at a uniform speed. After the car has covered a distance of 30 m the angle of depression becomes 60° . If the time taken by the car to reach the building from this point is 10 seconds then find the speed of the car and the height of the building.

Solution : Let AB be the building and its height be h meters. Also,

$$BC = x \text{ meter}$$

Given,

$$CD = 30 \text{ m}$$

$$\angle ADB = 30^\circ$$

$$\angle ACB = 60^\circ$$

Then in right angle triangle ABD

$$\tan 30^\circ = \frac{AB}{DB}$$

$$\frac{1}{\sqrt{3}} = \frac{h}{30+x}$$

$$h = \frac{30+x}{\sqrt{3}} \dots\dots\dots(1)$$

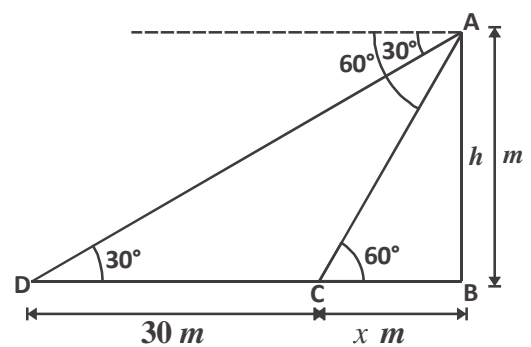

Figure - 16

Again in right angle triangle ABC,

$$\tan 60^\circ = \frac{AB}{BC}$$

$$\sqrt{3} = \frac{h}{x}$$

$$h = x\sqrt{3} \quad \dots\dots\dots(2)$$

From equations (1) and (2),

$$\frac{30+x}{\sqrt{3}} = x\sqrt{3}$$

$$\Rightarrow 30 + x = 3x$$

$$\Rightarrow 2x = 30$$

$$\Rightarrow x = 15 \text{ m}$$

Thus, height of the building $h = x\sqrt{3} = 15\sqrt{3} \text{ m}$

According to the question,

The time taken to reach the building from point C is 10 seconds.

$$\begin{aligned} \therefore \text{Speed of car} &= \frac{\text{Distance}}{\text{Time}} \\ &= \frac{15}{10} \\ &= 1.5 \text{ m/s} \end{aligned}$$

Exercise - 1

1. The angle of elevation of the top of a tower from a point on the ground, which is 90 m away from the foot of the tower, is 30° . Find the height of the tower.
2. There is a vertical column which is 3h meter tall. Find the angle of elevation from a point $\sqrt{3}h$ meters away from the base of the vertical column.
3. A kite is flying at a height of 60 m above the ground. The string attached to the kite is temporarily tied to a point on the ground. The inclination of the string with the ground is 60° . Find the length of the string, assuming that there is no slack in the string.
4. The angle of elevation of the top of a building from the foot of a tower is 30° and the angle of elevation of the top of the tower from the foot of the building is 60° . If the building is 15 m high, find the height of the tower.

5. Two towers are at a distance of 120 meters from each other. The angle of depression from the top of the second tower to the top of the first tower is 30° . If the second tower is 40 m high then find the height of the first tower.

6. If the angles of elevation of the top of the tower from two points at distances of a and b cm from the base of the tower and in the same straight line with it, are complementary, then show that the height of the tower is \sqrt{ab} .

7. The angle of elevation is 60° from the top of a 15 m high building to the top of a tower and the angle of depression to the bottom of the tower is 30° . Find the height of the tower and the distance between the tower and the building.

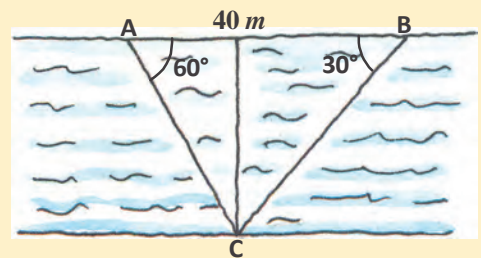

Figure - 17

8. The distance between two points A and B on the same side of a riverbank is 40 m. There is a point C on the opposite, parallel river bank such that $\angle BAC=60^\circ$ and $\angle ABC=30^\circ$ (Figure-17). Find the width of the river.

9. The angles of depression on a point P on the ground made by the peak of a temple and the flag on top of it are 30° and 60° respectively. If the temple is 10 m high, find the height of the flag (Figure-18).

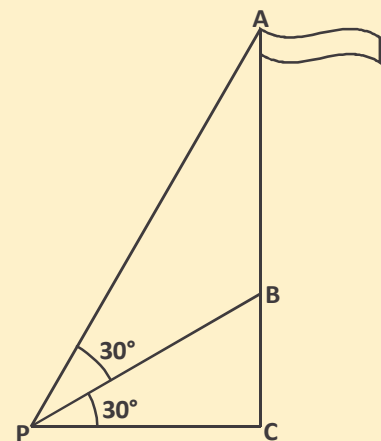

Figure - 18

10. Two electricity poles of equal height are on the opposite sides of a 40 m wide road. The angles of depression formed by the two poles at a point on the road are 30° and 60° respectively. Find the height of the poles and their respective distance from the point.

11. An observer spots a balloon moving at a height of 90 m above the horizon. If at a certain time the angle of elevation made by the balloon with the observer's eyes is 45° which reduces to 30° after some time then find the distance covered by the balloon (figure-19).

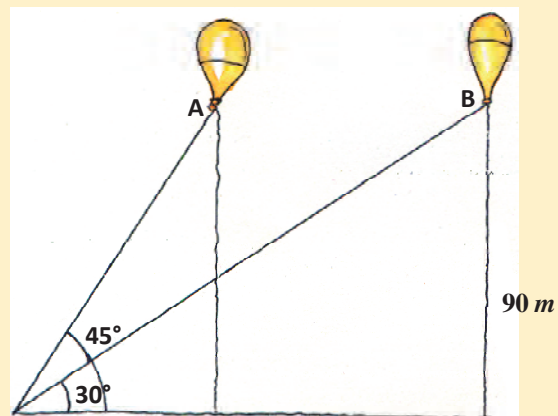

Figure - 19

What we have learnt

1. Trigonometric ratios can be used to find the relative distances and heights of trees, buildings, towers, planets, stars etc.
2. The ray joining the eye of the observer with the object being observed is called the ray of vision.
3. The angle of elevation is the angle formed between the ray of vision of the observed object and the horizon.
4. The angle of depression is the angle formed between the ray of vision of the observed object and the horizon, when the object is below the horizon.
5. The angle of elevation between a building, tower etc. and a point at some distance from the base of the building increases with increase in the height of the object.
6. The angle of depression between a building, tower etc. and a point at some distance from the base of the building decreases with increase in distance between the observer and the object.

ANSWER KEY

Exercise - 1

- | | |
|--|----------------------------------|
| (1) $30\sqrt{3}$ meter | (2) 60° |
| (3) 120 meter | (4) 45 meter |
| (5) $40(\sqrt{3}+1)$ meter | (7) 60 meter, $15\sqrt{3}$ meter |
| (8) $10\sqrt{3}$ meter | (9) 20 meter |
| (10) $10\sqrt{3}$ meter, at a distance of 10 m from the first pole and 30 meter from the second pole | |
| (11) $90(\sqrt{3}-1)$ meter | |

SIMILARITY IN GEOMETRICAL SHAPES

Introduction

We see various types of shapes around us, of which some are small in size and some are big. Some of them are circular, some are cubical, some are triangular, and others can be taken as a mix of different shapes.

See figure-1. In the given picture showing a house we are able to see many kinds of geometrical shapes. For example, we can see rectangles and triangles.

Can you find some more shapes of different kinds in the figure, which are not triangular or rectangular? What are these shapes? Discuss with your friends.

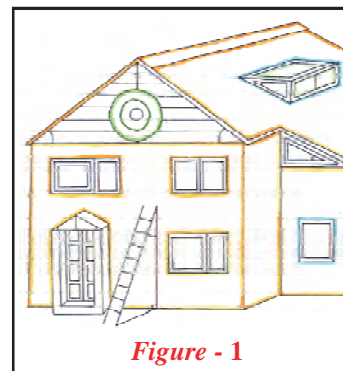

Figure - 1

Same Shapes:- If we carefully observe the figure then we find that there are some shapes where both the shape and the size are same. This means that they are congruent.

Now carefully observe figure-2. In figure-2(i), three triangles are drawn. The angles of the triangles appear equal and the sides look bigger or smaller in some fixed proportion. That is why all 3 triangles in figure-2(i) seem similar. But in figure-2(ii), the angles of both triangles are different. Therefore, by looking itself we can say that these two triangles appear different.

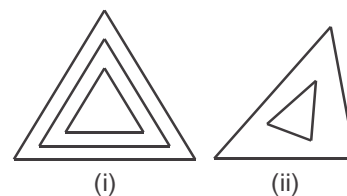

Figure - 2

Generally, the shapes which look same are called similar but there are certain conditions for similarity in mathematics. Are all 3 triangles similar in 2(i)? When we observe these triangles, they all look similar but how can we confirm? Later in the chapter we will discuss if they are similar or not and why.

Scaling

We often encounter situations where we have to enlarge a picture or draw the map of some farm, house, factory or field on paper. We may be asked to calculate actual distances, size, shape or area from the maps. We use scaling to meet our requirements in such situations.

Meaning of scaling is change in size, that is, increase or decrease (reduce) the size of a given shape. But before we enlarge or reduce a figure we need to keep certain conditions in mind so that the new figure is similar to the earlier one. What do we mean when we say that it should *look the same as earlier*?

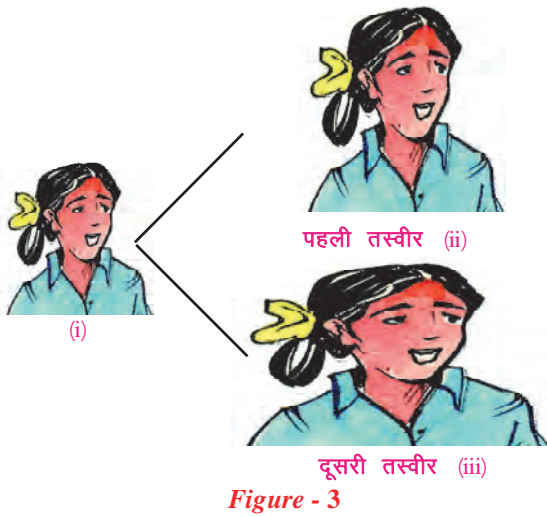

Figure - 3

See the pictures given in figure-3. Our attempts to enlarge figure-3(i), gave us 3(ii) and 3(iii). Which picture will you select from these two? Obviously, the first one. In this, the picture has been enlarged in such a way that it remains close to the original picture, 3(i). To do this, the picture has been enlarged in a fixed ratio. We can say that picture 3(i) and 3(ii) are similar.

Now look at the picture in figure-3(iii). The ratio of the width to height in this picture appears more than that in the original picture. It looks different from the picture in figure-3(i). Hence pictures in 3(i) and 3(ii) are not similar.

Therefore, for scaling, we have to be careful while increasing or decreasing the size so that the shape of the picture is not disturbed and property of similarity remains intact.

Scale Factor

The measurements of two similar shapes are fixed in a particular ratio called the scale factor. By using scale factor size of any figure can be increased or reduced in a fixed proportion, as per our requirements.

For example, to change a 5 cm long line segment to 10 cm long line segment, we have to use scale factor 2, because $5 \times 2 = 10$. Similarly, to change a $50 \text{ cm} \times 20 \text{ cm}$ map into a $10 \text{ cm} \times 4 \text{ cm}$ map, the scale factor is $\frac{1}{5}$ or 0.2 because $50 \times \frac{1}{5} = 10 \text{ cm}$,

$20 \times \frac{1}{5} = 4 \text{ cm}$. So, while scaling the line segment became twice the original length and the

map reduces by $\frac{1}{5}$ or 0.2. We can see that in the map, the ratio in which the second side was reduced is the same as the ratio in which the first side was reduced. If the scale factor is more than 1 then new shape is larger and if the scale factor is less than 1 then the new figure is smaller than the original figure.

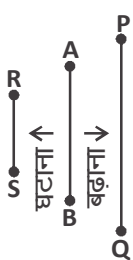

Figure - 4

Now look at figure 4. On increasing the size of \overline{AB} we obtain \overline{PQ} and by reducing the line segment we obtain \overline{RS} . Assume that the scale factor is x .

(i) Dilation/Enlargement

$$PQ = x(AB) \text{ (since } x \text{ is scale factor)}$$

$$\frac{PQ}{AB} = x$$

Because $PQ > AB$, therefore $x > 1$

Hence, to increase the size of any figure the scale factor must be bigger than 1.

(ii) Reduction

$RS = x(AB)$ (Because x is the scale factor)

$$\frac{RS}{AB} = x$$

Because $RS < AB$, therefore $x < 1$

Clearly, the scale factor must be less than 1 to reduce the figure.

Try These

1. What should be the scale factor to change a line segment of length 12 cm into 36 cm and similarly change line segment of 12 cm into 6 cm?

Mapping and Scaling

In drawing the maps of villages, districts, states and countries, we have to depict a large area on paper. Different scales are taken in mapping. If in the map of Chhattisgarh state, the scale is given as 1 cm : 50,00,000 cm or 1 cm : 50 km, what can we conclude from this information?

According to Rohit, if 1 cm : 50 km is written on the map then it means that 1 cm on the map represents 50 km in reality. Therefore, 2 cm represents, $50 \times 2 = 100$ km and 40 cm represents $50 \times 4 = 200$ km.

Do you agree with Rohit? How much is the scale factor here? Discuss with your friends.

Think & Discuss

1. What size of scale you would take to make the map of your village? Why?
2. (i) You have to draw the map of India ($20 \text{ cm} \times 20 \text{ cm}$), which is given in your book onto a wall ($3 \text{ m} \times 2 \text{ m}$). Can you make it by using the scale factor $1 \text{ m} = 12 \text{ cm}$?
(ii) If not then why not?
(iii) What maximum scale factor should be taken to draw the map on a wall of size $6 \text{ m} \times 4 \text{ m}$?
3. To make the map of your district and tehsil, which scale will you take and why?

Exercise - 1

1. In the map of a farm the scale is 1 cm to 1 m. In the map, the area of farm is shown as $3 \text{ cm} \times 4 \text{ cm}$. Find out the actual area of the farm in square meters?
2. You have a square shaped painting of area 3600 square cm. We will take scale factor 0.1 to scale the painting. Find the measure of one side after scaling the painting.
3. In city map, the distance between the Railway station and Airport is given as 3 cm. If the scale of map is 2 cm : 7 km then find out the real distance between the Airport and Railway Station?

Similarity in Squares and Circles

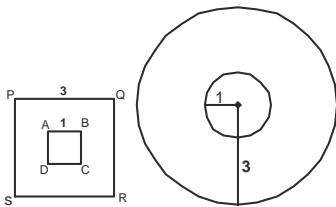

Figure - 5

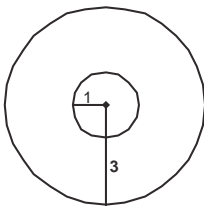

Figure - 6

In this part, we will discuss similarity in squares, circles, parallelograms and triangles. 2 squares of sides 1 cm and 3 cm are shown in figure-4. Are both squares similar?

Because the measure of each angle of every square is 90° , their angles are equal and each side of a square equals the others. Therefore, in both the squares all sides are in the same proportion. Therefore, both the squares are similar. Now, we see that by increasing each side of the square ABCD 3 times, we got the square PQRS. It means that here the scale factor is 3.

Now, we are given 2 circles in figure-5. Radius of one circle is 1 cm and that of the other circle is 3 cm. Are both circles similar?

We can make the circle of 3 cm by expanding the radius of circle of 1 cm. Or, by reducing the radius of circle of 3 cm we can make the circle of radius 1 cm. Hence, we can say that both circles are similar.

Draw circles having different radii in your notebook and check whether they are similar or not.

Think & Discuss

- Are all squares similar?
- Are all circles similar?

Similarity in other shapes

Circle and square are two different kinds of shapes and they can be determined by fixing only one component, the radius or the side respectively. During scaling we have to maintain the shape and in these two shapes the properties of similarity are present. But not in other shapes. The parameters to check for similarity are different for different shapes.

Then how can we identify whether two shapes are similar or not. For this, it will be useful to determine and fix some special properties of similar shapes.

Similarity in Polygons

When we say that 2 polygons are similar it means that when we reduce or enlarge by a fixed scale factor, all corresponding sides increase or decrease in the same proportion. Hence, it is necessary **for similarity in polygons that all corresponding angles are equal and all corresponding sides are in same proportion.**

Now, we will study about similarity in triangles and between rectangles and also discuss about the methods to check for similarity.

Test for Similarity in Rectangles

See the figure of a rectangle drawn on graph paper (figure-7). If rectangle ABCD is the original figure, then are rectangles PQRS and LMNO similar to the original figure? They appear to be similar but we have to find out whether these shapes are actually similar or not.

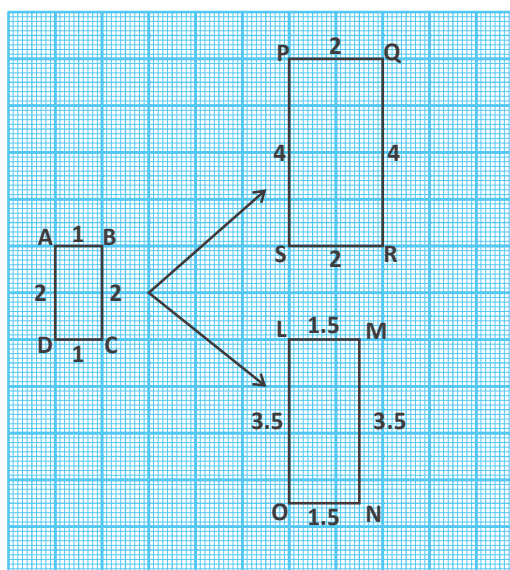

Figure - 7

Each angle of a rectangle is equal to 90° . Hence, the angles of all rectangles are equal. Since the sides opposite to each other in a rectangle are equal therefore to check similarity between rectangles, we need to check only the ratio of two adjacent sides, not all 4 sides. Complete the table given below by looking at figure-7.

Table - 1

Lengths of Sides		Ratio of Adjacent Sides
Rectangle ABCD	Rectangle PQRS	
AB = 1	PQ = 2	$\frac{PQ}{AB} = \frac{2}{1}$
BC = 2	QR = 4	$\frac{QR}{BC} = \frac{4}{2} = \frac{2}{1}$

Ratio of adjacent sides of rectangles PQRS and ABCD are same. This ratio

$$\frac{PQ}{AB} = \frac{QR}{BC} = 2$$

$$\therefore \frac{PQ}{AB} = \frac{QR}{BC} = \frac{RS}{CD} = \frac{SP}{DA} = 2$$

Thus, the ratios of all corresponding sides of rectangle PQRS and ABCD are equal. Here, the scale factor is 2. Side PQ is twice of side AB and both rectangles are similar. We can write it as follows: rectangle ABCD \sim rectangle PQRS, where ' \sim ' this is the symbol for similarity.

Table - 2

AB = 1	LM = 1.5	$\frac{LM}{AB} = \frac{1.5}{1}$
BC = 2	MN = 3.5	$\frac{MN}{BC} = \frac{3.5}{2} = \frac{1.75}{1}$

Now look at table-2 and compare the rectangles ABCD and LMNO. Is rectangle ABCD similar to rectangle LMNO?

Here, the ratio of one of the corresponding sides of the two rectangles 1.5 is and ratio of other pair of adjacent sides is 1.75. Since corresponding sides are not in the same ratio therefore rectangle ABCD and rectangle LMNO are not similar.

Try These

The adjacent figure depicts two blankets. If both blankets are similar, then:-

- What is the scale factor?
- Find the value of x .
- What is the ratio of the perimeter to the area of the rectangle?

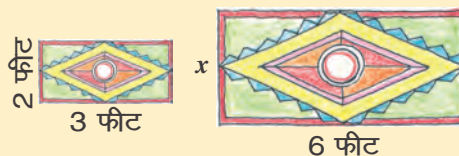

Division of Line Segment in Fixed Proportion

Point L and M are present on line segment \overline{AB} and \overline{CD} . If $\frac{AL}{LB} = \frac{CM}{MD}$ then we can say

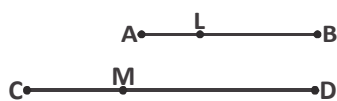

that, line segments \overline{AB} and \overline{CD} are respectively divided by L and M in the same ratio. We can use this property to check similarity between triangles.

Theorem-1 : If we draw a line which is parallel to any side of a triangle and intersects the other two sides at different points, then this line divides these two lines in the same ratio.

Proof : We are given triangle ABC in which the line DE is parallel to BC, and intersects the two sides AB and AC at points D and E.

We have to prove that : $\frac{AD}{DB} = \frac{AE}{EC}$

Join B to E and C to D and draw $DM \perp AC$ and $EN \perp AB$.

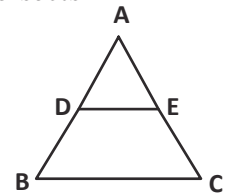

Figure - 8 (i)

Because the area of $\triangle ADE = \frac{1}{2} \times \text{Base} \times \text{Height}$

$$= \frac{1}{2} \times AD \times EN$$

Therefore, we can write the area of $\triangle ADE$ as ar (ADE)

$$\text{Therefore ar (ADE) = } \frac{1}{2} \times AD \times EN$$

$$\text{and ar (BDE) = } \frac{1}{2} \times DB \times EN$$

Similarly, $\text{ar (ADE) = } \frac{1}{2} \times AE \times DM$ and $\text{ar (DEC) = } \frac{1}{2} \times EC \times DM$

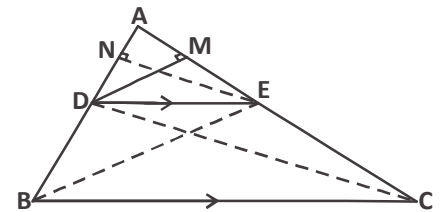

Figure - 8 (ii)

$$\text{Therefore } \frac{\text{ar(ADE)}}{\text{ar(BDE)}} = \frac{\frac{1}{2} \times AD \times EN}{\frac{1}{2} \times DB \times EN} = \frac{AD}{DB} \quad \dots\dots\dots (1)$$

$$\text{and } \frac{\text{ar(ADE)}}{\text{ar(DEC)}} = \frac{\frac{1}{2} \times AE \times DM}{\frac{1}{2} \times EC \times DM} = \frac{AE}{EC} \quad \dots\dots\dots (2)$$

Note that, $\triangle BDE$ or $\triangle DEC$ are two triangles sharing the same base DE and drawn between the same parallel lines BC and DE.

$$\text{Therefore, ar(BDE) = ar(DEC)} \quad \dots\dots\dots (3)$$

Hence, from (1), (2) and (3)

$$\frac{AD}{DB} = \frac{AE}{EC} \quad (\text{this is a basic theorem of proportionality})$$

Converse of this theorem can also be proved. Let us see:-

Theorem-2: If a line divides any two sides a triangle in the same ratio then this line is parallel to the third side.

Proof: To prove this theorem we can select a line PQ such that:

$\frac{AP}{PB} = \frac{AQ}{QC}$ And then assume the opposite, that is, we assume that PQ is not parallel to BC.

If PQ is not parallel to side BC, then some other line will be parallel to BC.

Let PQ' is one such line which is parallel to BC.

Therefore, $\frac{AP}{PB} = \frac{AQ'}{Q'C}$ (By basic proportionality theorem)

But $\frac{AP}{PB} = \frac{AQ}{QC}$

Thus $\frac{AQ}{QC} = \frac{AQ'}{Q'C}$

Adding 1 to both sides

$$\frac{AQ}{QC} + 1 = \frac{AQ'}{Q'C} + 1$$

$$\frac{AQ+QC}{QC} = \frac{AQ'+Q'C}{Q'C}$$

$$\therefore \frac{AC}{QC} = \frac{AC}{Q'C} \quad \text{Hence, } QC=Q'C$$

But this is possible only if Q and Q' are one and same point.

Therefore, $PQ \parallel BC$

Let us see some more examples based on this theorem.

Example-1. If line intersects sides AB and AC of $\triangle ABC$ at points D and E respectively

and is parallel to BC then prove that $\frac{AD}{AB} = \frac{AE}{AC}$ 1

Solution : $DE \parallel BC$ (Given)

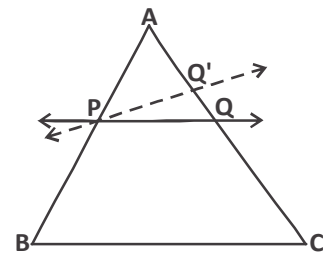

Figure - 9

Therefore, $\frac{AD}{DB} = \frac{AE}{EC}$

i.e. $\frac{DB}{AD} = \frac{EC}{AE}$

Or $\frac{DB}{AD} + 1 = \frac{EC}{AE} + 1$

Or $\frac{DB+AD}{AD} = \frac{EC+AE}{AE}$

Or $\frac{AB}{AD} = \frac{AC}{AE}$

Hence, $\frac{AD}{AB} = \frac{AE}{AC}$

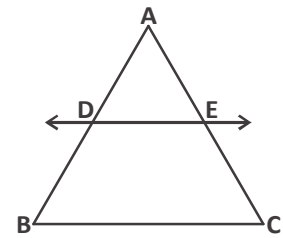

Figure - 10

Example-2. QRST is a trapezium, in which $QR \parallel TS$. Points E and F are located on non-parallel sides QT and RS in such a manner that EF is parallel to side

QR. Show that $\frac{QE}{ET} = \frac{RF}{FS}$.

Solution : Join Q to S such that QS intersects EF at point G.

$QR \parallel TS$ and $EF \parallel QR$ (Given, see figure-10(ii))

Therefore $EF \parallel TS$ (Two lines parallel to the same line are also mutually parallel)

Now, in $\triangle QTS$, $EG \parallel TS$ (Because $EF \parallel TS$)

Therefore, $\frac{QE}{ET} = \frac{QG}{GS}$ (1)

Similarly, in $\triangle SQR$

$$\frac{GS}{QG} = \frac{FS}{RF} \text{ which means } \frac{QG}{GS} = \frac{RF}{FS} \text{ (2)}$$

By equations (1) and (2) $\frac{QE}{ET} = \frac{RF}{FS}$

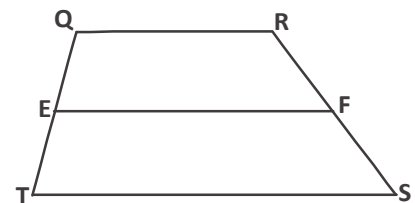

Figure - 11 (i)

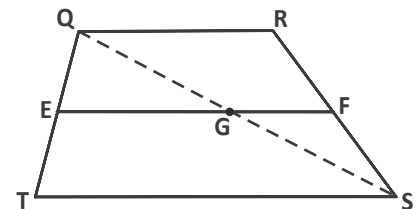

Figure - 11 (ii)

Exercise-2

1. The radius of a circular field is 52 meter. Draw the map of this field on paper in which the scale is 13 m : 1 cm. What is the radius of the field on the map on paper?
2. The measure of 2 corresponding sides of any rectangle are 5 cm and 7.5 cm. Calculate the area and length of sides of new rectangles formed by taking the new scale factors shown below:

- (i) 0.8 (ii) 1.2 (iii) 1.0

If scale factor of 1 is taken then will the new rectangle formed be congruent to the original figure?

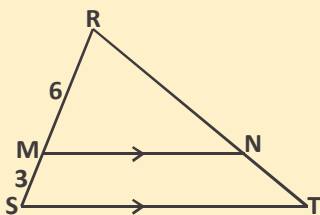

Figure - 12 (i)

3. In figure-12 (i), $MN \parallel ST$ then find the value of following:-

- (i) $\frac{TN}{NR}$ (ii) $\frac{TR}{NR}$ (iii) $\frac{TN}{RT}$

4. By using the basic proportionality theorem prove that the line which is drawn from the midpoint of a side of triangle, parallel to another side, bisects the remaining side?

5. In figure-12 (ii), $DF \parallel AE$ and $DE \parallel AC$

Prove that $\frac{BF}{FE} = \frac{BE}{EC}$.

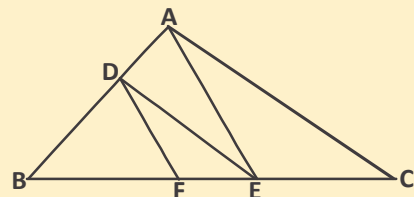

Figure - 12 (ii)

6. In ΔPQR points E and F are located on sides PQ and PR respectively. Then for the given conditions find out whether $EF \parallel QR$:

- (i) $PE = 3.9 \text{ cm}$, $EQ = 3 \text{ cm}$, $PF = 3.6 \text{ cm}$ and $FR = 2.4 \text{ cm}$.
 (ii) $PE = 4 \text{ cm}$, $QE = 4.5 \text{ cm}$, $PF = 8 \text{ cm}$ and $RF = 9 \text{ cm}$.
 (iii) $PQ = 1.28 \text{ cm}$, $PR = 2.56 \text{ cm}$, $PE = 0.18 \text{ cm}$ and $PF = 0.36 \text{ cm}$.

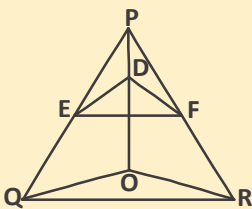

Figure - 12 (iii)

7. In figure-12 (iii), $DE \parallel OQ$ and $DF \parallel OR$.

Show that $EF \parallel QR$.

8. In figure-12 (iv), the points A, B and C are located respectively on OP, OQ or QR in such a way that $AB \parallel PQ$ and $AC \parallel PR$. Show that $BC \parallel QR$.

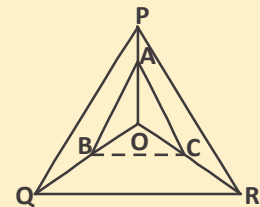

Figure - 12 (iv)

Note : If needed draw a figure to solve the question. It makes it easier to find the solutions.

Similarity in Parallelograms

Are the conditions/properties used to test for similarity in rectangles sufficient to check for similarity in parallelograms? Obviously these are not enough, because in parallelograms all angles are not equal. Therefore, we have to look for one more theorem.

Theorem-3. If in 2 parallelograms corresponding angles are equal, then their corresponding sides are in the same ratio. Hence, such parallelograms are similar.

Proof : According to the statement given in theorem-3, select 2 parallelograms ABCD and PQRS,

Where, $\angle A = \angle P, \angle B = \angle Q$

And, $\angle C = \angle R, \angle D = \angle S$ (Figure-13(i), (ii))

In the parallelogram PQRS join S to Q and take two points A' and C' on PS and SR respectively, such that-

$AD = A'S, DC = SC'$

And $\angle DAB = \angle SA'B'$ then join B' to C'

Now, $\triangle A'SB'$ in $\angle SPQ = \angle SA'B'$ (Given)

$\therefore A'B' \parallel PQ$ (Transversal line PS intersects the lines PQ and A'B' and the corresponding angles made are equal).

Now, $A'B' \parallel PQ \parallel SR$ in $\triangle PSQ$, then by basic proportionality theorem-

$$\frac{PS}{A'S} = \frac{PQ}{A'B'} = \frac{QS}{B'S} \quad (\text{Why?})$$

$$\frac{PS}{AD} = \frac{PQ}{AB} = \frac{QS}{B'S} \quad (\text{Why?}) \quad \dots\dots\dots(1)$$

$$\text{In the same way, in } \triangle SQR \quad \frac{SR}{SC'} = \frac{QR}{B'C'} = \frac{QS}{B'S}$$

$$\text{Or } \frac{SR}{CD} = \frac{QR}{BC} = \frac{QS}{B'S} \quad (\text{Why?}) \quad \dots\dots\dots(2)$$

From (1) and (2)

$$\frac{PQ}{AB} = \frac{QR}{BC} = \frac{SR}{CD} = \frac{PS}{AD} \quad (\text{Why?})$$

Hence, if we assume that the corresponding angles of 2 parallelograms are equal, then we find that their 4 corresponding sides are in the same ratio.

Will the converse also be true?

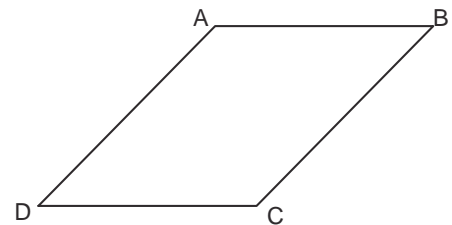

Figure - 13 (i)

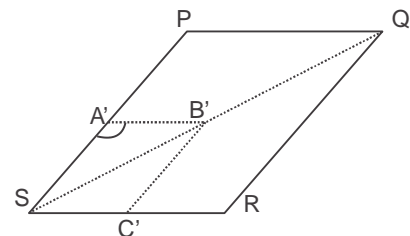

Figure - 13 (ii)

Theorem-4. If corresponding sides of two parallelograms are in the same ratio and their corresponding angles are equal then these parallelogram are similar.

Proof : Prove the statement given above.

Conclusion :

We can conclude from the two theorems given above that for similarity it is sufficient that any one of the two conditions - that is, (i) corresponding angles are equal (ii) corresponding sides are in same ratio - is satisfied. In similarity between parallelograms it is not required that both the criteria be satisfied because fulfillment of one criteria implies that the other is also satisfied.

Similarly, we can test for similarity in other pairs of polygons (parallelogram, pentagon, etc).

Try These

1. Are given parallelograms similar? Explain your answers –

(i) ABCD and EFGH

(ii) ABCD and JKLM

(iii) ABCD and NOPQ

(iv) JKLM and NOPQ

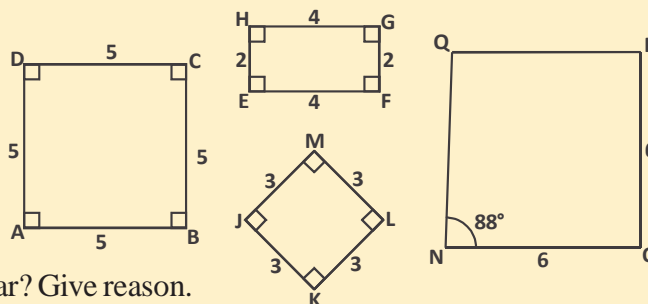

2. Are EFGH and JKLM similar? Give reason.

3. Draw a parallelogram similar to EFGH?

Are congruent figures also similar?

Let us understand the relation between similarity and congruency.

2 parallelograms EFGH and WXYZ are congruent which means that $EFGH \cong WXYZ$, and therefore their corresponding adjacent sides and corresponding angles are equal.

$$\therefore EF = WX, FG = XY, GH = YZ \text{ and } HE = ZW$$

$$\text{Or } \frac{EF}{WX} = 1, \frac{FG}{XY} = 1, \frac{GH}{YZ} = 1 \text{ and } \frac{HE}{ZW} = 1$$

$$\therefore \frac{EF}{WX} = \frac{FG}{XY} = \frac{GH}{YZ} = \frac{HE}{ZW} = 1$$

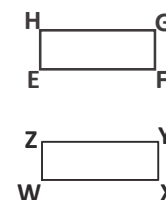

Figure - 14

Clearly, the sides of both the quadrilaterals are in the same proportion, therefore these quadrilaterals are similar. This means that both the conditions of similarity are satisfied in congruency.

Think & Discuss

Are all similar figures, congruent? Explain with reasons.

Relation between Perimeters of Similar Shapes

If two shapes are similar, can we tell the relation between the perimeters of these shapes? Suppose, two similar polygons are given to us in which the scale factor is m . According to the properties of similarity,

$$\frac{AB}{PQ} = \frac{BC}{QR} = \frac{CD}{RS} = \frac{DA}{SP} = m \text{ (Adjacent sides are in the same proportion).....(1)}$$

$$AB = mPQ \quad \text{.....(2)}$$

$$BC = mQR \quad \text{.....(3)}$$

$$CD = mRS \quad \text{.....(4)}$$

$$\text{And } DA = mSP \quad \text{.....(5)}$$

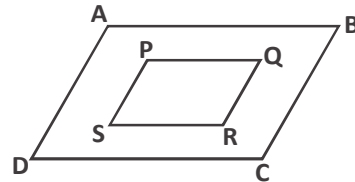

Let us find their perimeters:

$$\text{Perimeter of polygon } ABCD = AB + BC + CD + DA \quad \text{.....(6)}$$

$$\text{And, perimeter of polygon } PQRS = PQ + QR + RS + SP \quad \text{.....(7)}$$

From (6) and (7)

$$\frac{\text{Perimeter of polygon } ABCD}{\text{Perimeter of polygon } PQRS} = \frac{AB + BC + CD + DA}{PQ + QR + RS + SP}$$

From (2), (3), (4) and (5)

$$\frac{\text{Perimeter of polygon } ABCD}{\text{Perimeter of polygon } PQRS} = \frac{m(PQ + QR + RS + SP)}{(PQ + QR + RS + SP)}$$

$$\frac{\text{Perimeter of polygon } ABCD}{\text{Perimeter of polygon } PQRS} = m = \frac{AB}{PQ} = \frac{BC}{QR} = \frac{CD}{RS} = \frac{DA}{SP} \quad \text{From (1)}$$

It means that the ratio of the perimeters of 2 similar polygons is equal to the ratio of their corresponding sides and their scale factor.

Example-3. If quadrilateral $ABCD \sim$ quadrilateral $PQRS$, then:-

- (i) What is the scale factor? (that of quadrilateral $ABCD$ with $PQRS$)
- (ii) Find the value of x , y and z .

- (iii) What is the perimeter of the quadrilateral ABCD?
 (iv) What is the ratio of the perimeters of the two quadrilaterals?

Solution : (i) Ratio of adjacent sides:-

$$\frac{CD}{RS} = \frac{20}{30} = \frac{2}{3} \text{ (Scale factor)}$$

- (ii) Because the given quadrilaterals are similar therefore their adjacent sides are in same proportion:-

$$\frac{CD}{RS} = \frac{AB}{PQ}$$

$$\therefore \frac{2}{3} = \frac{x}{21}$$

$$x = 14$$

$$\text{And } \frac{CD}{RS} = \frac{BC}{QR}$$

$$\frac{2}{3} = \frac{8}{y}$$

$$y = 12$$

$$\frac{CD}{RS} = \frac{AD}{PS}$$

$$\frac{2}{3} = \frac{10}{z}$$

$$z = 15$$

- (iii) Perimeters of quadrilaterals ABCD is-

$$10 + 20 + 8 + 14 = 52 \text{ units}$$

- (iv) Ratio of perimeters of the two quadrilaterals is,

$$\frac{\text{Perimeter of quadrilateral ABCD}}{\text{Perimeter of quadrilateral PQRS}} = \frac{2}{3} \text{ which is equal to the scale factor.}$$

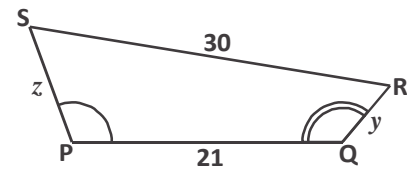
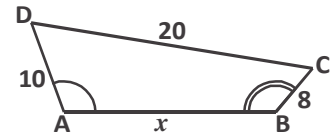

Exercise - 3

1. If in the given figure polygons are similar then find the value of the following:-

- OP
- EA
- $m\angle OPL$
- $m\angle LMN$
- Polygon $DEABC \sim ?$
- The statement polygon $BCDEA \sim$ polygon $NOPLM$ is not correct. Correct it.

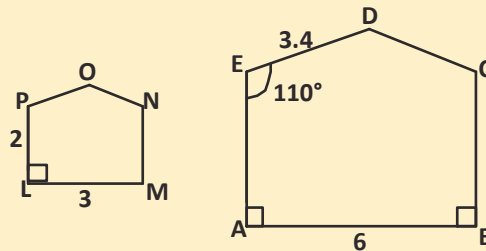

2. If in figure-(i) triangle are similar and in figure-(ii) quadrilaterals are similar then find the value of x and y .

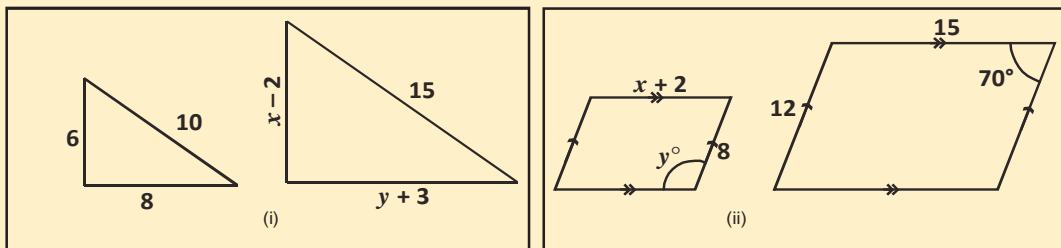

3. If in the given figure each pair of polygons is similar, then find the value of x , y and z ?

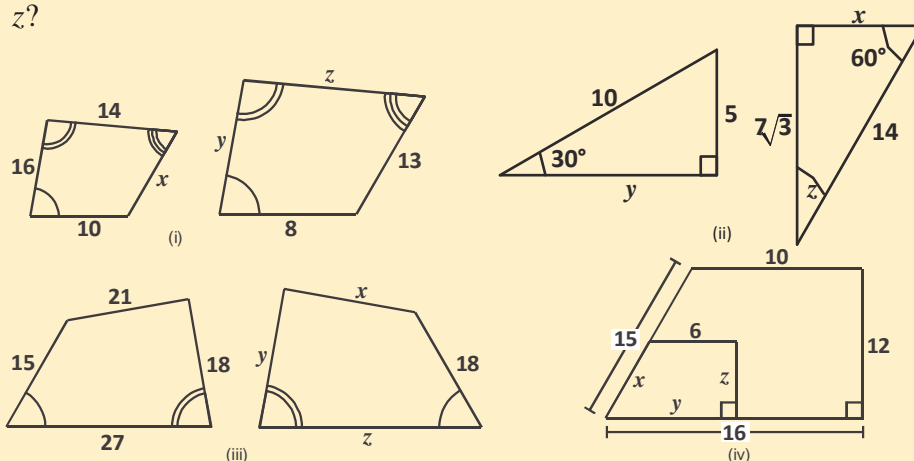

4. The lengths of the sides of a quadrilateral are 4 cm , 6 cm , 6 cm and 8 cm . The lengths of the sides of another quadrilateral, which is similar to the first quadrilateral, are 6 cm , 9 cm , 9 cm and 12 cm .

- What is the scale factor? (The second quadrilateral from the first quadrilateral)
- Find the perimeter of both the quadrilaterals.
- What is the ratio of their perimeters? (The first quadrilateral from the second quadrilateral)

5. Give examples for the following and give reasons:-
- If two polygons are congruent, then they are similar as well.
 - If two polygons are similar, then it is not necessary that they are congruent.
 - Think and write three more statements.

How to check for similarity in triangles?

So far we have seen that two conditions/criteria for proving that any two triangles are similar. They are:-

- Corresponding angles should be equal

$$\angle P = \angle X, \quad \angle Q = \angle Y, \quad \angle R = \angle Z$$

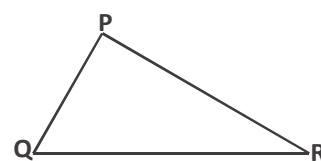

Figure - 15 (i)

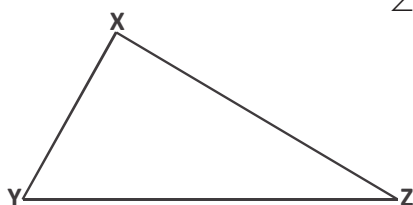

Figure - 15 (ii)

- Ratio of corresponding sides are similar:-

$$\frac{PQ}{XY} = \frac{QR}{YZ} = \frac{RP}{ZX}$$

Then $\Delta PQR \sim \Delta XYZ$

If any one condition is satisfied then we can say that both triangles are similar.

Angle-Angle-Angle (AAA) similarity criterion: If in two triangles, the corresponding angles are equal then their corresponding sides are in the same ratio and thus the two triangles are similar. This is called the angle-angle-angle (AAA) similarity criterion.

Let see what minimum conditions can fulfill these criteria.

Angle-Angle (AA) similarity: If two angles of one triangle are equal to two angles of another triangle respectively then the two triangles are similar.

This is the Angle-Angle criterion for similar triangles.

By using this criterion, we will prove two other criteria, SAS and SSS.

Theorem-5. Side-Angle-Side (S-A-S) similarity theorem : If one angle of a triangle is equal to one angle of another triangle and the sides including these angles are proportional, then the two triangles are similar.

Proof : To prove this theorem, we take two triangles ABC and DEF in which

$$\frac{AB}{DE} = \frac{AC}{DF} (<1) \text{ which means that DE is greater than AB and } \angle A = \angle D$$

We take two points P and Q on DE and DF in such a way that $DP = AB$ and $DQ = AC$.

Now join P to Q.

$$\frac{DP}{DE} = \frac{DQ}{DF} \quad \left(\because \frac{AB}{DE} = \frac{AC}{DF} \right)$$

$\therefore PQ \parallel EF$ (By basic proportionality theorem)

Hence, $\angle P = \angle E$ और $\angle Q = \angle F$ (Why?)

Hence, $\triangle ABC \cong \triangle DPQ$

($AB = DP$; $AC = DQ$ and
 $\angle BAC = \angle PDQ$)

$\therefore \angle B = \angle E$ और $\angle C = \angle F$

According to Angle-Angle similarity criterion, $\triangle ABC$ and $\triangle DEF$ are similar.

Hence, $\triangle ABC \sim \triangle DEF$

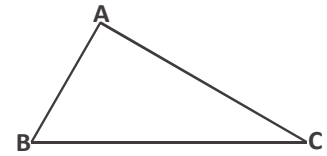

Figure - 16 (i)

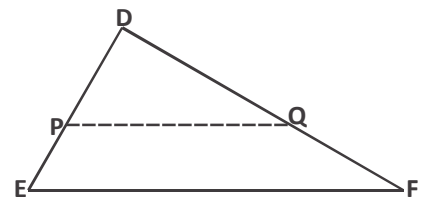

Figure - 16 (ii)

Theorem-6. Side-Side-Side (S-S-S) Similarity Theorem : If in 2 triangles sides of one triangle are proportional to the sides of the second triangle then both these triangles are similar.

Proof :

To prove this theorem, we take two triangles ABC and DEF in which

$$\frac{AB}{DE} = \frac{BC}{EF} = \frac{CA}{FD}$$

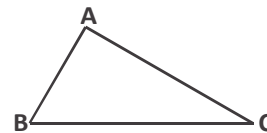

Figure - 17

In $\triangle DEF$, we select two points P and Q on sides DE and DF such that $DP = AB$ and $DQ = AC$. Join P to Q.

Here, $\frac{DP}{DE} = \frac{DQ}{DF}$ ($\because \frac{AB}{DE} = \frac{CA}{FD}$ and $DP = AB$, $DQ = AC$)

$\therefore PQ \parallel EF$ (Why?) (Theorem-2)

Thus $\angle P = \angle E$ and $\angle Q = \angle F$

$\therefore \triangle DEF \sim \triangle DPQ$ (Angle-Angle similarity)

We know that $\triangle ABC \cong \triangle DPQ$ (From the given construction)

$\therefore \angle A = \angle D$, $\angle B = \angle E$ and $\angle C = \angle F$

Hence, $\triangle ABC \sim \triangle DEF$ (From Angle-Angle similarity)

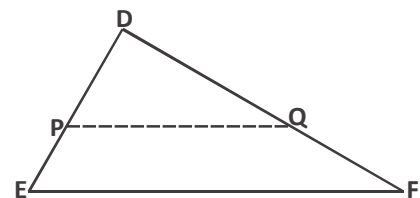

Figure - 18

Example-4. If $PQ \parallel RS$, then prove that
 $\Delta POQ \sim \Delta SOR$ (Figure-19)

Solution : $PQ \parallel RS$ (Given)

$\angle P = \angle S$ (Alternate Angles)

And $\angle Q = \angle R$ (Alternate Angles)

Also, $\angle POQ = \angle SOR$ (Vertically opposite angles)

$\therefore \Delta POQ \sim \Delta SOR$ (Angle-Angle-Angle similarity criterion)

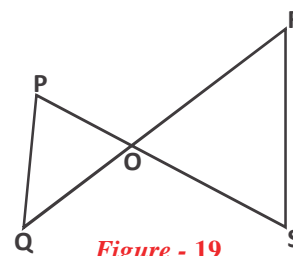

Figure - 19

Example-5. A girl of height 90 cm is walking away from the base of the lamp post at a speed of 1.2 m/s. If the lamp bulb is 3.6 m above the ground, find the length of her shadow after 4 seconds.

Solution : Let height of the bulb of lamp-post be AB and height of girl be CD. From the figure, you can see that DE is the shadow of the girl.

Let $DE = x$ meter

Because distance = Speed \times Time

Therefore, $BD = 1.2 \times 4 = 4.8$ m

In ΔABE and ΔCDE ,

$\angle B = \angle D$ (Each is of 90° , because lamp-post as well as the girl are standing vertical on the ground)

$\angle E = \angle E$ (Same angle)

So, $\Delta ABE \sim \Delta CDE$ (AA similarity criterion)

Therefore, $\frac{BE}{DE} = \frac{AB}{CD}$ (Corresponding sides of similar triangles)

$\frac{4.8 + x}{x} = \frac{3.6}{0.9}$ (Because 1 m = 100 cm)

$4.8 + x = 4x$

$3x = 4.8$

$x = 1.6$

So, the shadow of the girl after walking 4 seconds will be 1.6m long.

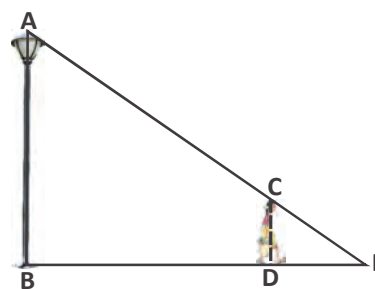
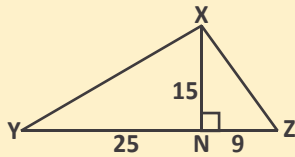

Figure - 20

Try These

1. Check for similarity in the triangles given below and explain which criterion is used:-



(i)

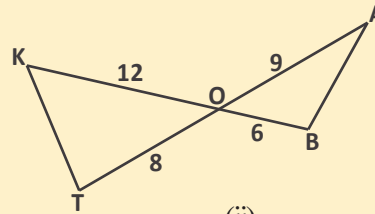

(ii)

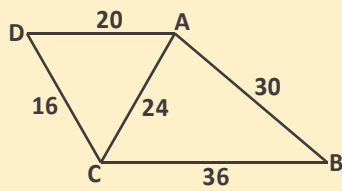

(iii)

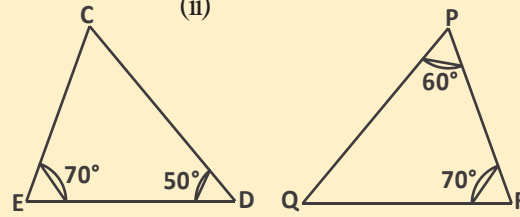

(iv)

(i) $\triangle YXN$ and $\triangle XNZ$ (ii) $\triangle OAB$ and $\triangle OKT$ (iii) $\triangle ADC$ and $\triangle ACB$ (iv) $\triangle CED$ and $\triangle PRQ$

Relations Between the Areas of Similar Triangles

In similar polygons we saw that the ratio of their perimeters is equal to the ratio of their corresponding sides. Then in two triangles ABC and PQR

$$\frac{\text{Perimeter } \triangle ABC}{\text{Perimeter } \triangle PQR} = \frac{AB}{PQ} = \frac{BC}{QR} = \frac{CA}{RP}$$

Or
$$\frac{AB + BC + CA}{PQ + QR + RP} = \frac{AB}{PQ} = \frac{BC}{QR} = \frac{CA}{RP}$$

Is there any relation between the areas of these triangles and their corresponding sides?

We will see the relation in the next theorem.

Theorem-7. The ratio of the area of 2 similar triangles is equal to the ratio of their corresponding sides.

Proof: We are given two triangles such that $\triangle ABC \sim \triangle PQR$

We have to prove that:

$$\frac{\text{ar}(ABC)}{\text{ar}(PQR)} = \left(\frac{AB}{PQ}\right)^2 = \left(\frac{BC}{QR}\right)^2 = \left(\frac{CA}{RP}\right)^2$$

To calculate the area of both the triangles, we will draw their altitudes AM and PN respectively.

$$\text{Now, ar}(ABC) = \frac{1}{2} \times BC \times AM \quad \text{and}$$

$$\text{ar}(PQR) = \frac{1}{2} \times QR \times PN$$

$$\frac{\text{ar}(ABC)}{\text{ar}(PQR)} = \frac{\frac{1}{2} \times BC \times AM}{\frac{1}{2} \times QR \times PN} = \frac{BC \times AM}{QR \times PN} \quad \dots\dots\dots (1)$$

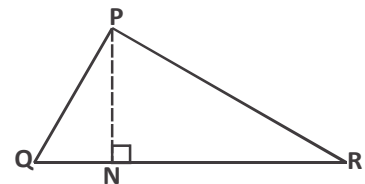
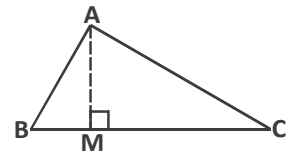

Now, in $\triangle ABM$ and $\triangle PQN$

$$\angle B = \angle Q \quad (\triangle ABC \sim \triangle PQR)$$

$$\angle M = \angle N \quad (\text{Each angle is } 90^\circ)$$

$\therefore \triangle ABM \sim \triangle PQN$ (Angle-Angle similarity)

$$\text{Therefore, } \frac{AM}{PN} = \frac{AB}{PQ} \quad \dots\dots\dots (2)$$

We know that

$$\triangle ABC \sim \triangle PQR \quad (\text{Given})$$

$$\text{Then } \frac{AB}{PQ} = \frac{BC}{QR} = \frac{CA}{RP} \quad \dots\dots\dots (3)$$

From equation (1) and (3)

$$\frac{\text{ar}(ABC)}{\text{ar}(PQR)} = \frac{AB}{PQ} \times \frac{AM}{PN}$$

From equation (2)

$$\frac{\text{ar}(ABC)}{\text{ar}(PQR)} = \frac{AB}{PQ} \times \frac{AB}{PQ} = \left(\frac{AB}{PQ}\right)^2$$

$$\text{Thus, from equation (3) } \frac{\text{ar}(ABC)}{\text{ar}(PQR)} = \left(\frac{AB}{PQ}\right)^2 = \left(\frac{BC}{QR}\right)^2 = \left(\frac{CA}{RP}\right)^2$$

Try These

1. If the ratio of the area of two similar triangles is 25:9 then what will be the ratio of their corresponding sides?
2. If triangle TFR and triangle SPM are similar and their scale factor is 7:4 then what is the ratio of their areas?
3. $\Delta PQR \sim \Delta XYZ$, Where $PQ = 3XY$.
What is the ratio of their areas?

Exercise-4

1. ABCD is a parallelogram. Find the values of x and y .
2. We are given a trapezium ABCD in which $AB \parallel DC$ and its diagonals intersect at point O. If $AB = 2CD$, then find the ratio of the area of triangle AOB and COB.
3. In the given figure if $IV = 36$ meter, $VE = 20$ meter and $EB = 15$ meter, then what is the width of the river?
4. If the areas of two similar triangles are equal to each other, then prove that the triangles are congruent.
5. Prove that the ratio of the area of two similar triangles is the square of the ratio of their corresponding medians.
6. Sahid is trying to estimate the height of a pole. He is standing in such a manner that the shadow of his head 'H' and the shadow of the top of the pole 'Q' fall on the same point, D. If $DE = 1.6$ m and $DF = 4.4$ m then what is the height of the pole?

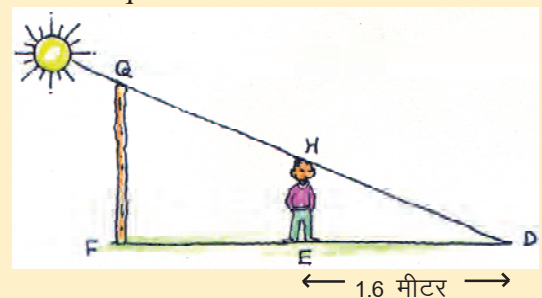
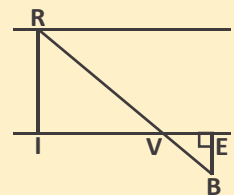
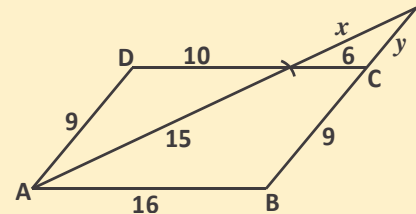

7. (i) In the figure, which two triangles are similar to the triangle ABC? Name them.
(ii) Find the value of x and y .

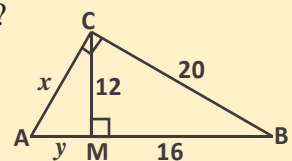

8. ABC and BDE are two equilateral triangles such that D is the midpoint of side BC. Ratio of area of triangles ABC and BDE is:-
(i) 2:1 (ii) 1:2 (iii) 4:1 (iv) 1:4
9. If in two similar triangles $9ar(ABC) = 16ar(PQR)$, then the value of $\frac{AB}{PQ}$ is:-
(i) 4:3 (ii) 16:3 (iii) 3:4 (iv) 9:4

Pythagoras Theorem

In your earlier classes you solved many problems by using the Pythagoras Theorem. You also verified this theorem through some activities. Can we prove this theorem by using the concept of similarity of triangles? Let us see –

Theorem-8. If a perpendicular is drawn on the hypotenuse from the vertex of the right angle of a right angle triangle then triangles on both sides of the perpendicular are similar to the original triangle as well as to each other.

Proof : **Given :** Triangle $\triangle ABC$ which is right angled at B and BD is perpendicular to the hypotenuse AC.

We have to prove that-

$$(i) \quad \triangle ADB \sim \triangle ABC$$

$$(ii) \quad \triangle BDC \sim \triangle ABC$$

$$(iii) \quad \triangle ABD \sim \triangle DBC$$

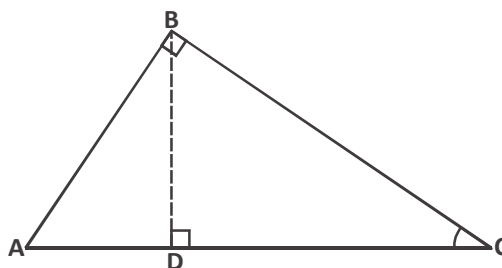

We may note that in $\triangle ADB$ and $\triangle ABC$

$$\angle A = \angle A \quad (\text{Common angle})$$

$$\angle ADB = \angle ABC \quad (\text{both angles are } 90^\circ)$$

$$\therefore \triangle ADB \sim \triangle ABC \quad (\text{How?}) \quad \dots\dots (1)$$

Similarly in $\triangle BDC$ and $\triangle ABC$

$$\angle C = \angle C \quad \text{and} \quad \angle BDC = \angle ABC \quad (\text{Why?})$$

$$\text{Therefore, } \triangle BDC \sim \triangle ABC \quad \dots\dots (2)$$

From (1) and (2)

$$\triangle ADB \sim \triangle BDC \quad \dots\dots (3)$$

(If any two triangles are similar to a third triangle then both the triangles are also similar to each other)

Now, we will prove the Pythagoras Theorem by using this theorem.

Theorem-9. In a right angle triangle, the square of the hypotenuse is equal the sum of the squares of the other two sides.

Proof : We are give a right triangle ABC which is right angled at B.

$$\text{We need to prove that } AC^2 = AB^2 + BC^2$$

To prove this theorem, we need to construct or draw a perpendicular BD from the vertex B on side AC.

Now in $\triangle ADB$ and $\triangle ABC$

$\angle ADB = \angle ABC = 90^\circ$
 $\angle A = \angle A$ (Common angle)
 $\therefore \triangle ADB \sim \triangle ABC$ (Angle-Angle similarity)

$$\therefore \frac{AD}{AB} = \frac{AB}{AC} \text{ (Proportional sides)}$$

$$\text{Or } AD \cdot AC = AB^2 \text{ (1)}$$

Similarly $\triangle BDC \sim \triangle ABC$

$$\therefore \frac{CD}{BC} = \frac{BC}{AC} \text{ (Proportional sides)}$$

$$\text{Or } CD \cdot AC = BC^2 \text{ (2)}$$

On adding equations (1) and (2)

$$AD \cdot AC + CD \cdot AC = AB^2 + BC^2$$

$$\text{Or } AC (AD + CD) = AB^2 + BC^2$$

$$\text{Or } AC \cdot AC = AB^2 + BC^2$$

$$\text{Or } AC^2 = AB^2 + BC^2$$

Can we prove the converse of this theorem?

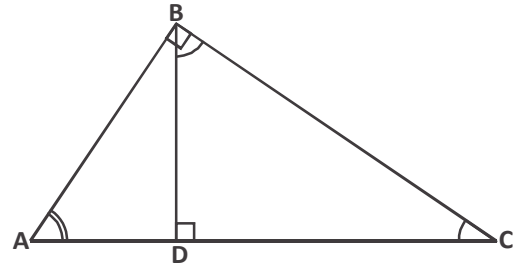

Theorem-10. In a triangle, if square of one side is equal to the sum of the squares of the other two sides, then the angle opposite the first side is a right angle.

Proof : Prove it on your own.

Let us solve some problems by using these theorems.

Try These

A ladder is placed against a wall such that its foot is at a distance of 2.5 m from the wall and its top reaches a window 6 m above the ground. Find the length of the ladder.

Example-6. In figure $AD \perp BC$ है।

Prove that $AB^2 + CD^2 = BD^2 + AC^2$ है।

Solution : In $\triangle ADC$

$$AC^2 = AD^2 + CD^2 \text{ (By Pythagoras Theorem) (1)}$$

Now, in $\triangle ADB$

$$AB^2 = AD^2 + BD^2 \text{ (2)}$$

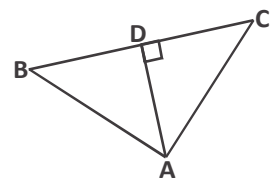

On subtracting (1) from (2)

$$AB^2 - AC^2 = BD^2 - CD^2$$

$$\text{Or } AB^2 + CD^2 = BD^2 + AC^2$$

Example-7. BL and CM are the medians of a right angle triangle ABC which is right angled at A. Prove that $4(BL^2 + CM^2) = 5BC^2$.

Solution : In $\triangle ABC$, $\angle A = 90^\circ$ and BL and CM are the medians.

$$\text{In } \triangle ABC \quad BC^2 = AB^2 + AC^2 \text{ (Why?)}$$

$$\text{In } \triangle ABL \quad BL^2 = AL^2 + AB^2$$

$$BL^2 = \left(\frac{AC}{2}\right)^2 + AB^2$$

(L is mid point of AC)

$$BL^2 = \frac{AC^2}{4} + AB^2$$

$$4BL^2 = AC^2 + 4AB^2 \dots\dots\dots (2)$$

$$\text{In } \triangle CMA \quad CM^2 = AC^2 + AM^2$$

$$CM^2 = AC^2 + \left(\frac{AB}{2}\right)^2$$

(M is the midpoint of AB)

$$4CM^2 = 4AC^2 + AB^2 \dots\dots\dots (3)$$

By adding (2) or (3)

$$4BL^2 + 4CM^2 = AC^2 + 4AB^2 + 4AC^2 + AB^2$$

$$4(BL^2 + CM^2) = 5AC^2 + 5AB^2$$

$$4(BL^2 + CM^2) = 5(AC^2 + AB^2)$$

$$4(BL^2 + CM^2) = 5BC^2 \quad \text{From (1)}$$

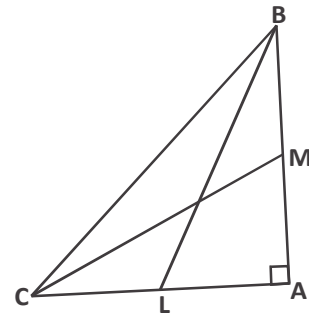

Exercise-5

1. Which of the pairs given below is not similar? Why?

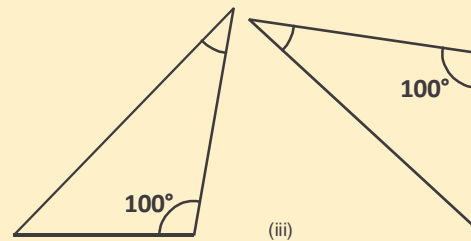
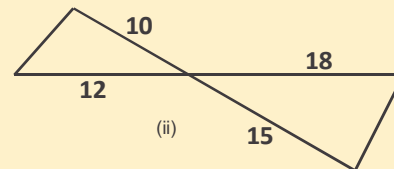
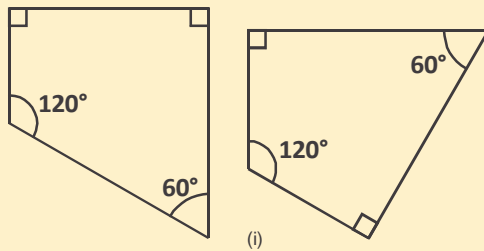

2. Megha made 2 similar kites. The diagonal of the bigger kite is 1.5 times the diagonal of the smaller kite. Then-
- What is the scale factor?
 - Find the length of the diagonal of the bigger kite, given that $BD = 40$ cm and $AC = 68$ cm.

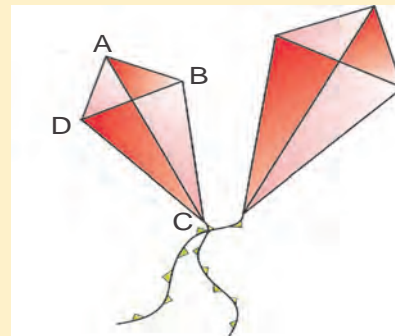

3. In a right triangle ΔPQR , P is the right angle and M is the point on QR such that $PM \perp QR$. Show that $PM^2 = QM \cdot MR$.

4. ABC is an equilateral triangle of side $2a$. Find the length of the each altitude.
5. ΔABC is an isosceles triangle in which $\angle C = 90^\circ$. Prove that $AB^2 = 2AC^2$.

6. If in the given figure
- $$OR' = 2 \cdot OR$$
- $$OS' = 2 \cdot OS$$
- $$OT' = 2 \cdot OT$$

Then prove that $\Delta RST \sim \Delta R'S'T'$

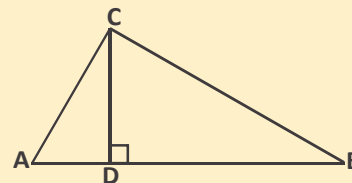
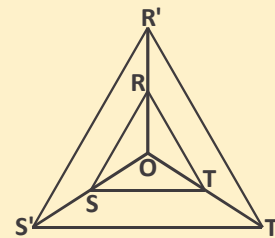

7. Triangle ABC is right angled at C . Point 'D' and 'E' are located on sides CA and CB respectively. Prove that $AE^2 + BD^2 = AB^2 + DE^2$.

8. In triangle ACB , $\angle ACB = 90^\circ$ and $CD \perp AB$. Prove that $\frac{BC^2}{AC^2} = \frac{BD}{AD}$
9. The diameter of earth is approximately 8000 miles and that of sun is 864000 miles; the distance between sun and earth is approximately 92 million miles.
If on paper we take the diameter of earth as 1 inch then what will be the diameter of sun and the distance between the sun and earth on paper? (1 million = 10^6).
10. If the ratio of the perimeters of two regular hexagon is 5 : 4 then what is the ratio of their sides?

What we have learnt

1. The measurements of 2 similar shapes are in a fixed ratio which is called scale factor.
2. Two polygons having the same number of sides are similar, if
 - (i) their corresponding angles are equal, and
 - (ii) their corresponding sides are in the same ratio.
3. If a line is drawn parallel to one side of a triangle such that it intersects the other two sides at distinct points then it divides the other two sides in the same ratio.
4. If a line divides any two sides of a triangle in the same ratio, then the line is parallel to the third side.
5. All congruent polygons are also similar.
6. The ratio of the perimeter of any two similar polygons is same as the ratio of their corresponding sides, or their scale factor.
7. If in two triangles, two angles of one triangle are respectively equal to two angles of other triangle, then two triangles are similar (AA similarity criterion).
8. If one angle of a triangle is equal to one angle of another triangle and the sides including these angles are in the same ratio then the two triangles are similar (SAS similarity criterion).
9. If in two triangles corresponding sides are in the same ratio, then their corresponding angles are equal and hence the triangles are similar.
10. The ratio of the area of two similar triangles is equal to the ratio of their corresponding sides.

11. If in a right triangle a perpendicular is drawn from the vertex of the right angle to its hypotenuse then the triangles on both sides of the perpendicular are similar to the first triangle and also to each other.
12. In a right triangle, the square of the hypotenuse is equal to the sum of the squares of the other two sides.
13. If in a triangle, square of one side is equal to the sum of the squares of the other 2 sides, then the angle opposite the first side is a right angle.

ANSWER KEY

Exercise - 1

1. 1200 Square meter 2. 6 cm 3. 10.5 cm

Exercise - 2

1. 4 cm 2. (i) 4 cm, 6 cm, 24 cm (ii) 6 cm, 9 cm, 54 cm
 (iii) 5 cm, 7.5 cm, 37.5 cm, Yes 3. (i) $\frac{1}{2}$ (ii) $\frac{3}{2}$ (iii) $\frac{1}{3}$
6. (i) No (ii) Yes (iii) Yes

Exercise - 3

1. (i) 1.7 (ii) 4 (iii) 110° (iv) 90° (v) Polygon OPLMN
 (vi) Polygon BCDEA is similar to polygon MNOPL
2. (i) $x = 11, y = 9$
 (ii) $x = 8, y = 110^\circ$
3. (i) $x = 16.25, y = 20, z = 17.5$

$$(ii) x = 7, y = 5\sqrt{3}, z = 30^\circ$$

$$(iii) \quad x = 25.2, y = 21.6, z = 32.4 \quad (iv) \quad x = 9, y = 9.6, z = 7.2$$

$$4. \quad (i) 1.5 \quad (ii) 24 \text{ cm}, 36 \text{ cm} \quad (iii) 1.5$$

Exercise - 4

$$1. \quad x = 9, y = \frac{27}{5} \quad 2. \quad 4:1 \quad 3. \quad 27 \text{ meter} \quad 6. \quad 3.3 \text{ meter}$$

$$7. \quad (i) \text{ Triangle ACM and Triangle CBM} \quad (ii) \quad x = 15, y = 9$$

$$8. \quad (iii) 4:1 \quad 9. \quad (i) 4:3$$

Exercise - 5

$$1. \quad (i) \quad \text{First is parallelogram, second is not.}$$

(iii) Since we know the value of only one angle therefore we cannot say anything about similarity.

$$2. \quad (i) 1.5 \quad (ii) 102 \text{ cm and } 60 \text{ cm}$$

$$4. \quad \sqrt{3}a \quad 9. \quad 108 \text{ inch}, 11500 \text{ inch} \quad 10. \quad 5:4$$

CIRCLE AND TANGENTS

Introduction

When we look around us we see objects having different shapes. For example, coins, bangles, wheels of a cycle, etc. All the items mentioned above have some common property.



Edge of a coin

Figure - 1



Edge of a bangle

Figure - 2



Edge of a wheel

Figure - 3

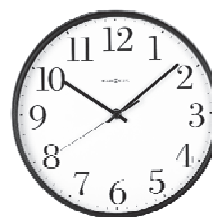

Edge of a clock

Figure - 4

The edges of all of these items seem circular. We can find many more items or objects similar to these items. Can you quickly think of six other similar objects? Balls, marbles, drops of water and many other similar things are spherical.



Ball

Figure - 5



Marbles

Figure - 6

These objects (figures–5 and 6) are different from a circle and from the other figures given above. Discuss among your classmates and write the differences between things which are similar to coins and things that resemble a football.

In this chapter we will look at the properties of surfaces of things like coins, that is, circular surfaces.

What is a circle?

Take a point “O” on paper and take another point “P”, 5 cm away from O.

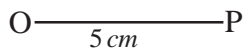

Figure - 1 (i)

Can we take some more points which are at a distance of 5 cm from the point O? How can we locate these points? How many such points are there?

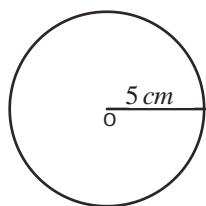

Figure - 1 (ii)

Take a compass and open it 5 cm wide. Put the tip of the compass on point O and mark point at a distance of 5 cm from O. On joining all points on paper which are at a distance of 5 cm from O, we will get the shape shown in figure 1(ii). This type of closed figure drawn on a plane is known as a circle. Circle is a group of points in a plane which are located at a fixed distance from a fixed point and which form a closed shape. Point O is called the center of the circle. The distance from the center to any point on the circle is called radius. Can we locate a point on a wheel or clock or bangle or coin, etc. from which the distance upto the tip is equal?



Try These

Write true or false giving reasons and examples.

1. Circle has multiple radii.
2. All radii of a circle are same.

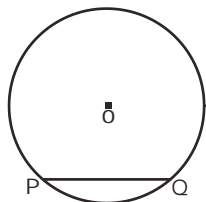

Figure - 2

Chord

Draw a circle on a paper and take two points on its perimeter. Two points, P and Q are shown in figure-2. On joining these two points we get a line segment PQ and this line segment is a chord of the circle. Can you imagine how many such lines are there whose end points lie on the circle? You will find there are infinite such chords.

Try These



1. Identify the chords in the figures given below.

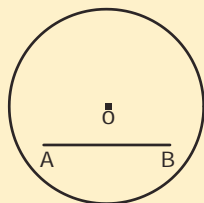

Figure - 3

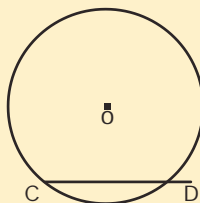

Figure - 4

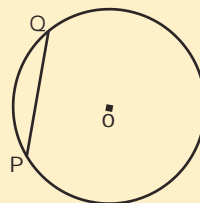

Figure - 5

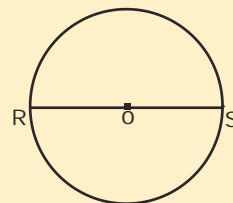

Figure - 6

2. Are all chords of same length?
3. Which is the longest chord?

Longest Chord of a Circle

See figure-7 which shows a circle whose center is O and in which various chords AB, CD, EF and MN, etc. Observe the lengths of these chords.

Between AB and MN, which chord is longer?

Between CD and MN, which chord is longer?

Similarly, which is the longer chord among EF and MN?

On comparing A_1B_1 and MN, we find that length of chord MN is more. Can you find any special property in chord MN which is not present in remaining chords?

Chord MN passes through the center of the circle. A chord which passes through the center of the circle is called diameter of circle. Given a circle, can you draw a chord which is longer than the diameter?

No, you will find that diameter is the greatest chord in a circle.

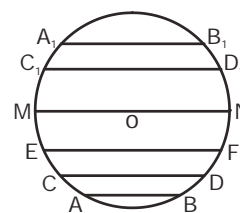

Figure - 7

Think and Discuss

Can we draw more diameters besides MN in figure-7? If yes, then how many diameters can be drawn?



Arc of a circle

If we take any two points on the perimeter of the circle then they will divide the circle in two parts (figures-8, 9, 10).

In this circle one part is small and the other is big. The smaller part of the circle is said to be minor arc \widehat{AMB} and the bigger part is said to be major arc \widehat{ANB} (figure-9).

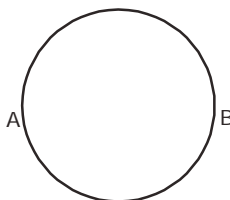

Figure - 8

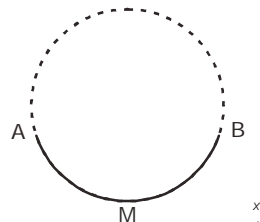

Figure - 9

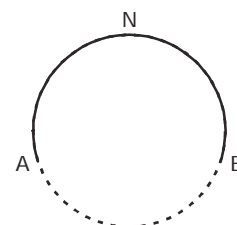

Figure - 10

In figure-8, if from point A we start moving in a circular path and reach back A, then distance travelled is perimeter of circle.

Segment of a Circle

Draw a chord AB in a circle. Can you tell the number of parts into which the internal part of the circle is divided by the chord (figure-11)? You can see that the chord divides the internal part of a circle in two parts. Area which lies within the chord and the arc is called segment of a circle. Area which is between chord and minor arc is called minor segment and area which is between chord and major arc is called major segment.

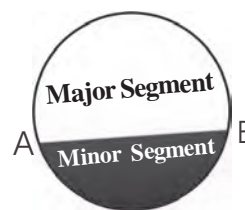

Figure - 11



Try These

Draw a circle on a paper and try to find relation between length of chord and corresponding minor segment by drawing various chords of different lengths.

We can see that when the length of a chord is less, then the area of minor sector will also be less.

Think and Discuss



1. Radius of a circle is 6 cm . The lengths of some its chords are 4 cm , 6 cm , 10 cm and 8 cm respectively. Write the major segments corresponding to these chords in increasing order of area.
2. In the circle given above where the radius is 6 cm , when the length of chord is 12 cm then what kind of relation will you find between major segment and minor segment?

Sector

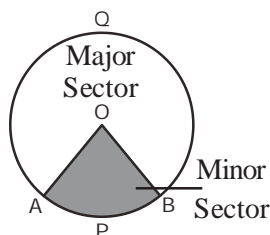

Figure - 12

Take two points A and B on a circle (see figure-12). Join the end points of arc AB with the center O. The area which lies between the two radii drawn from the end points of arc AB and the arc itself is called sector.

As in the case of segment, you will find that the area which is surrounded by minor arc and radii is called minor sector and area which is surrounded by major arc and radii is called major sector. OAPB is minor sector and OAQB is major sector.

Try These

Identify radius, chord, diameter, sector and segment in given figure and write in the table.

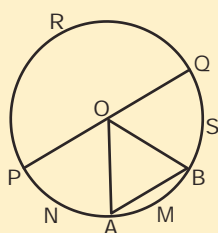

Figure - 13

Radius	Chord	Diameter	Arc	Sector	Segment

Congruent Circles

We saw that two figures which are able to completely cover each other are known as congruent figures.

Take two circles of equal radii and centers at O_1 and O_2 respectively. Take diameter AB in circle with center at O_1 and diameter CD in circle with center at O_2 (Figures-14, 15).

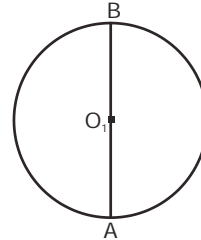

Figure - 14

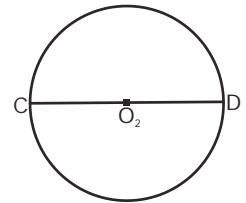

Figure - 15

Put the circles on one-another so that center O_1 lies exactly center O_2 and end points A and B of diameter AB lie on C and D respectively. You can see that one circle is completely covering another one and so we can say that both are congruent. Repeat this activity by drawing more pairs of circles with same radius.

You will find that circles with equal radius are congruent.

Subtended angle made by chord on center

We are given a line segment AB and a point O which does not lie on the line segment (Figure-16).

Join O to A and B . $\angle AOB$ is said to be the angle subtended by line segment AB on point O .

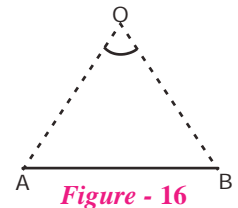

Figure - 16

We have a circle whose center is O and which has two chords are AB and CD (figure-17). Angles made by chord AB and CD are $\angle AOB$ and $\angle COD$ respectively. Can you tell which angle is greater, $\angle AOB$ and $\angle COD$? Can you see any relation between the length of chord and angle subtended by chord at the center? You can say that greater the length of chord greater is the angle subtended by it on the center.

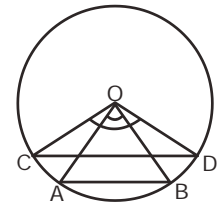

Figure - 17

Try These

Draw a circle with radius 5 cm . Draw pairs of chords of length 3 , 5 , 8 , 10 and 6 cm . Measure the angles made by chord on center and write in given table.

Length of chord	3 cm	5 cm	6 cm	8 cm	10 cm
Angles subtended					



After filling the above table you will find that in a circle, equal chords subtend equal angles at the center.

Some theorems related to circles

We have learnt different methods of proving geometrical statements. Now we consider some statements about circles which reflect the properties of circles. Let us take the same statement which we mentioned above, that is, in a circle equal chords subtend equal angles at the center.

Theorem - 1.

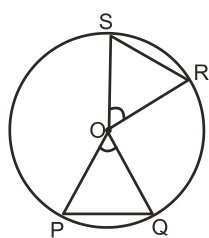

Figure - 18

Statement : Equal chord of a circle subtend equal angles at the center.

Given : A circle with center O where PQ and RS are two equal chords.

To Prove : $\angle POQ = \angle ROS$

Proof : In ΔPOQ and ΔROS

$$OP = OR \quad (\text{Radii of same circle})$$

$$OQ = OS \quad (\text{Radii of same circle})$$

$$PQ = RS \quad (\text{Given})$$

Thus, $\Delta POQ \cong \Delta ROS$ (SSS Congruency)

$\therefore \angle POQ = \angle ROS$ (Corresponding parts of congruent triangles)

Will the converse of this statement also be true, i.e. if angles made by chords at the center are equal, then the chords are equal. Let us prove this statement.

Theorem - 2.

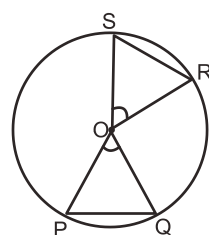

Figure - 19

Statement: If angles made by chords at the center of a circle are equal, then chords are also equal.

Given : A circle with center O with two chords PQ and RS and $\angle POQ = \angle ROS$

To Prove: $PQ = RS$

Proof : In ΔPOQ and ΔROS

$$OP = OR \quad (\text{Radii of same circle})$$

$$OQ = OS \quad (\text{Radii of same circle})$$

$$\angle POQ = \angle ROS \quad (\text{Given})$$

Thus, $\Delta POQ \cong \Delta ROS$ (SAS Congruency)

$\therefore PQ = RS$ (Corresponding parts of congruent triangles)

If two chords of a circle are equal, then their corresponding arcs are congruent and conversely, if two arcs are congruent, then their corresponding chords are also equal.

Example-1. In figure-20 if chords AB and BC are equal and $\angle AOB = 35^\circ$ then find $\angle AOC$.

Solution : $\angle AOB = \angle BOC$ (Equal chords in a circle subtend equal angles)

$$\angle BOC = 35^\circ \quad (\angle AOB = 35^\circ \text{ given})$$

$$\text{Thus, } \angle AOC = \angle AOB + \angle BOC$$

$$= 35^\circ + 35^\circ$$

$$= 70^\circ$$

$$\therefore \angle AOC = 70^\circ$$

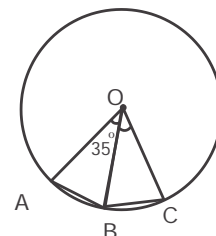

Figure - 20

Example-2. A regular pentagon is drawn in a circle. What will be the angle subtended at the center of the circle by each side of the pentagon?

Solution : All five sides of a regular pentagon are equal and they make equal angles at the center.

Let each side of the regular pentagon make angle x° at the center.

$$\text{Thus, } 5x^\circ = 360^\circ \text{ (Why?)}$$

$$x^\circ = \frac{360^\circ}{5}$$

$$\therefore x^\circ = 72^\circ$$

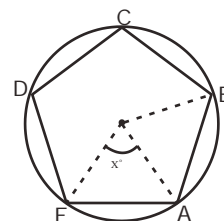

Figure - 21

Try These

1. A regular polygon is drawn inside a circle. Each side of the regular polygon makes an angle of 60° on center. Find the number of side of regular polygon.



Perpendicular from Center to Chord

On a piece of paper, draw a circle whose center is at O and where AB is a chord. Draw a perpendicular from center that meets AB at point M. What you can say about AM and BM?

Are they equal? How can we find out? Here, which mathematical arguments can we use? Can we use congruency of triangles?

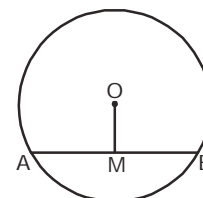

Figure - 22

Theorem - 3.

Statement: A perpendicular drawn from the center of a circle on to a chord bisects the chord.

Given : A circle with center at O and whose chord is AB and $OM \perp AB$

To Prove : $AM = MB$

Construction : Join O to A and B.

Proof : In $\triangle OMA$ and $\triangle OMB$

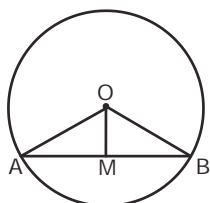

Figure - 23

$$OA = OB \quad (\text{Radii of same circle})$$

$$OM = OM \quad (\text{Common})$$

$$\angle OMA = \angle OMB \quad (\text{Right angles})$$

$$\triangle OMA \cong \triangle OMB \quad (\text{By Right angle – hypotenuse-side congruency})$$

Thus, $AM = MB$ (Corresponding parts of congruent triangles)

What is the converse of this theorem? Is the line drawn from the center which bisects the chord perpendicular to the chord?

Theorem - 4.

Statement : A line segment which joins the center of a circle and mid-point of a chord is perpendicular to the chord.

Given : A circle with center O. AB is chord and M is a mid-point of chord.

To Prove : $OM \perp AB$

Construction : Join O to A and B.

Proof : In $\triangle OMA$ and $\triangle OMB$

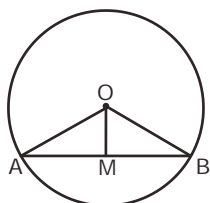

Figure - 24

$$OA = OB \quad (\text{Radii of same circle})$$

$$AM = MB \quad (\text{Given})$$

$$OM = OM \quad (\text{Common side})$$

$$\triangle OMA \cong \triangle OMB \quad (\text{SSS congruency})$$

Thus, $\angle OMA = \angle OMB$ (Corresponding parts of congruent triangles)

$$\angle OMA + \angle OMB = 180^\circ \quad (\text{By linear pair axiom})$$

$$\angle OMA + \angle OMA = 180^\circ \quad (\angle OMA = \angle OMB)$$

$$2\angle OMA = 180^\circ$$

$$\angle OMA = 90^\circ$$

Thus, $OM \perp AB$

Let us solve some examples of circle by using these properties of circles.

Example.-3. If radius of a circle is 5 cm then find the length of a chord which is 3 cm away from center.

Solution : In $\triangle OAC$, $OA = 5 \text{ cm}$ $OC = 3 \text{ cm}$

By Pythagoras theorem,

$$OA^2 = OC^2 + AC^2$$

$$5^2 = 3^2 + AC^2$$

$$AC^2 = 5^2 - 3^2$$

$$AC^2 = 25 - 9$$

$$AC^2 = 16$$

$$AC = 4$$

Thus, chord $AB = 2 \times AC = 8 \text{ cm}$

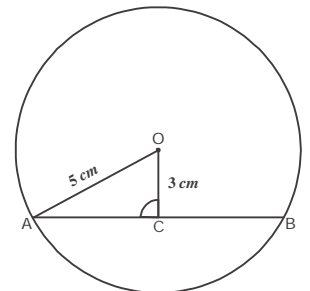

Figure - 25

Example-4. A chord which is 24 cm long is 5 cm away from center of the circle. Find the diameter of the circle.

Solution : $OR = 5 \text{ cm}$, chord $PQ = 24 \text{ cm}$

$$PR = \frac{1}{2} PQ \text{ cm}$$

$$= \frac{1}{2} \times 24$$

$$= 12 \text{ cm}$$

Using Pythagoras theorem in $\triangle OPR$

$$OP^2 = PR^2 + OR^2$$

$$= 12^2 + 5^2$$

$$= 144 + 25$$

$$= 169$$

$$OP = 13$$

$$\begin{aligned} \text{So, diameter of circle} &= 2 \times OP \\ &= 2 \times 13 \\ &= 26 \text{ cm} \end{aligned}$$

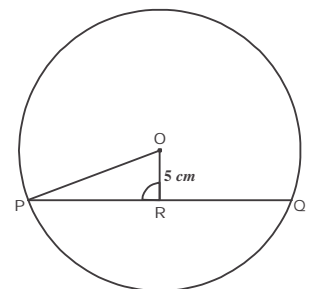

Figure - 26



Example-5. A line l intersects two concentric circles (circles with same center) on points A, B, C and D (See figure-27).

If $AD = 18 \text{ cm}$ and $BC = 8 \text{ cm}$ then find AB . Center of circle is O.

Solution : Draw a perpendicular OM from center O on line l (See figure-28)

$$OM \perp BC$$

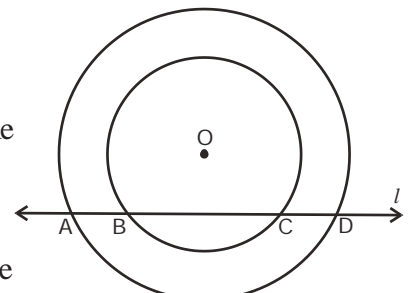

Figure - 27

$$\therefore \quad \text{BM} = \text{MC} \quad \dots (i)$$

$$\text{BM} + \text{MC} = \text{BC}$$

$$\text{BM} + \text{BM} = 8$$

$$2\text{BM} = 8$$

$$\text{BM} = 4 \text{ cm}$$

Similarly,

$$\text{OM} \perp \text{AD}$$

$$\text{AM} = \text{MD} \quad \dots (ii)$$

$$\text{AM} + \text{MD} = \text{AD}$$

$$2\text{AM} = 18$$

$$\text{AM} = 9 \text{ cm}$$

$$\text{So, } \text{AB} = \text{AM} - \text{BM}$$

$$= 9 - 4$$

$$= 5 \text{ cm}$$

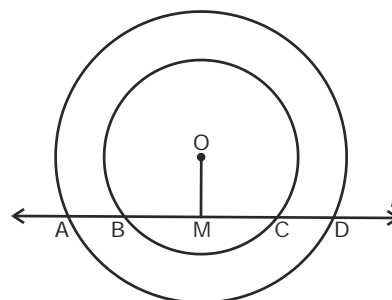

Figure - 28

Example-6. Two chords of a circle PQ and RS are parallel and AB is perpendicular bisector of PQ. Prove that AB also bisects chord RS.

Solution : We know that bisector of a chord of circle passes through center of circle. Chord AB is perpendicular bisector of PQ.

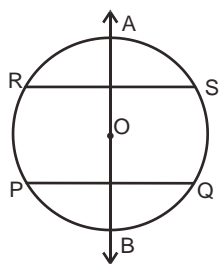

Figure - 29

\therefore AB passes through center of circle-

$$\text{AB} \perp \text{PQ} \text{ और } \text{PQ} \parallel \text{RS} \Rightarrow \text{AB} \perp \text{RS}$$

Thus, $\text{AB} \perp \text{RS}$ and AB passes through center of circle.

\therefore AB will be perpendicular bisector of chord RS.

Thus, AB bisects chord RS.



Try This

Find the length of the perpendicular drawn from the center of the circle of radius 5 cm on to a chord of length 6 cm.

Exercise - 1

- Find the length of chord of a circle, if-
 - Radius = 13 cm and distance of chord from center = 12 cm
 - Radius = 15 cm and distance of chord from center = 9 cm
- Find the radius of a circle if length of chord and its distance from center are respectively:
 - 8 cm and 3 cm
 - 14 cm and 24 cm
- PQ is diameter of a circle (figure - 30). $MN \perp PQ$ and $PQ=10$ cm and $PR=2$ cm then find the length of MN.

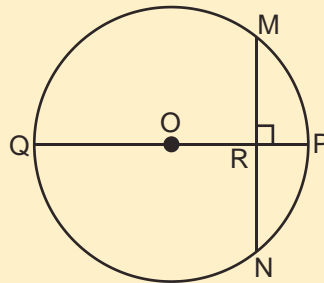

Figure - 30

- In figure-31 chord AB = 18 cm and PQ is perpendicular bisector of chord AB which meets the chord on point M. If $MQ = 3$ cm then find the radius of circle.

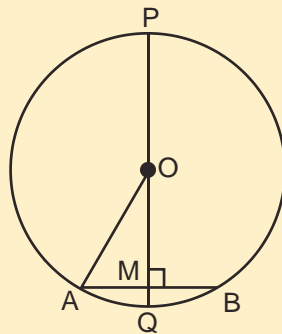

Figure - 31

- A circle with center O and chords PQ and OR such that $\angle PQO = \angle OQR = 55^\circ$. Prove that $PQ = QR$.
- AB and AC are two equal chords of a circle with center O. If $OD \perp AB$ and $OE \perp AC$ then prove that $\triangle ADE$ is isosceles triangle.

Circle which passes through three non-collinear points.

Take a point P on paper. Draw a circle which passes through point P. Can we draw one more circle which passes through point P? How many such circles can be drawn? (See figure-33)

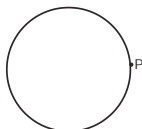

Figure - 32

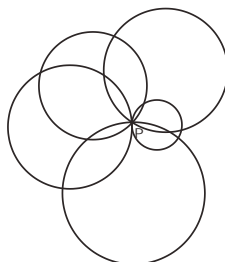

Figure - 33

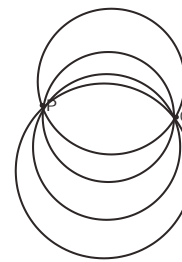

Figure - 34

You can see several circles can be drawn. Similarly, several circles can be drawn passing through two points P and Q (See figure-34). Can we draw a circle which passes through three non-collinear points?

Theorem - 5.

Statement : One and only one circle can be drawn such that it passes through three non collinear points.

Given : A, B and C are three non-collinear points.

To Prove : One and only one circle can be drawn through the points A, B and C.

Construction : Connect points A to B and B to C. Draw PL and QM which are perpendicular bisectors of AB and BC, respectively. Let PL and QM intersect each other at point O. Join O to A, B and C.

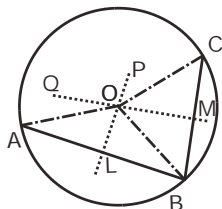

Figure - 35

Proof : Point O lies on PL which is perpendicular bisector of AB

\therefore $OA = OB$ (i) (Each point which lies on the perpendicular bisector of a line segment is at the same distance from the end points of the line segment)

Similarly, O lies on MQ which is perpendicular bisector of BC.

\therefore $OB = OC$ (ii)

$OA = OB = OC = r$ (Assume) (PL and QM will intersect at the same point). O is the only point which will be equidistant from the points A, B and C.

Hence, only one circle passes through three non-collinear points.

We use this fact to draw a circle through all three vertices of a triangle. The circle is known as the incircle of the triangle and its center is called incenter.

Try This

Arc of a circle is given (See figure-36).

Complete the circle after finding its center.



Figure - 36



Think and Discuss

Can we draw a circle which passes through three collinear points?

Chords and their distances from the center

Infinite chords can be drawn in a circle. Draw a circle of any radius. Draw parallel chords for this circle (see figure-37). Can you see any relation between lengths of chords and their distances from the center? Write the chords AB, CD and EF in descending order according to their distances from center. You will find that as the lengths of chords increase their distances from center decreases; thus, diameter is the longest chord in a circle whose distance from center is zero. Will the distances from center of chords be same if we take two equal chords? Let us verify this statement.

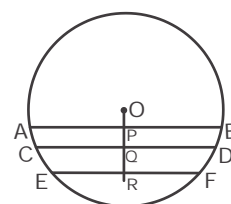

Figure - 37

Theorem - 6.

Statement : Equal chords of a circle (or congruent circles) are at the same distance from center (or from centers).

Given : A circle with center at O and two equal chords PQ and RS; OL and OM are perpendiculars from O to PQ and RS respectively.

To Prove : $OL = OM$

Construction : Join O to P and R.

Proof: $PQ = RS$ (Given)

$$\frac{1}{2}PQ = \frac{1}{2}RS$$

$$PL = RM$$

(Perpendicular drawn from center divides the chord into two equal parts)

$$OP = OR$$

(Radii of a circle)

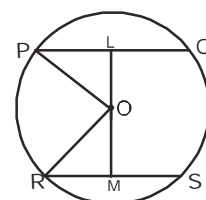

Figure - 38

$$\angle OLP = \angle OMR = 90^\circ \quad (\text{By construction})$$

$$\triangle OLP \cong \triangle OMR \quad (\text{By RHS congruency theorem})$$

$$\therefore OL = OM \quad (\text{Corresponding parts of congruent triangles})$$



Try This

Chords which are equidistant from the center of a circle are equal. Prove.

Let us solve some examples by using the above results.

Example-7. Radius of a circle is 20 cm. Difference between two equal and parallel chords is 24 cm. Find the lengths of the chords.

Solution :

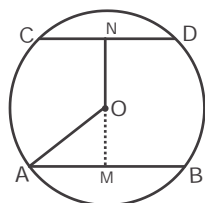

Figure - 39

$$OM = ON \quad \dots(i) \quad (\text{Equal chords are equidistant from center})$$

$$MN = OM + ON$$

$$MN = OM + OM \quad \text{by (i)}$$

$$24 = 2 OM$$

$$OM = 12 \text{ cm}$$

$$OA = 20 \text{ cm}$$

In $\triangle OAM$

$$OA^2 = OM^2 + AM^2$$

$$AM^2 = OA^2 - OM^2$$

$$= 20^2 - 12^2$$

$$= 400 - 144$$

$$= 256$$

$$AM = 16$$

So, length of chord $AB = 2 \times AM$

$$= 2 \times 16$$

$$= 32 \text{ cm}$$

Example-8. Two parallel chords which are 6 cm and 8 cm long respectively lie on opposite sides of center of a circle. The distance between chords AB and CD is 7 cm. Find the radius of circle.

Solution : Here, $AB = 6 \text{ cm}$

$$\begin{aligned} AN &= \frac{1}{2} AB \\ &= \frac{1}{2} \times 6 \end{aligned}$$

$$AN = 3 \text{ cm}$$

(Perpendicular drawn from center to chord bisects the chord)

Similarly $CD = 8 \text{ cm}$

$$\begin{aligned} CM &= \frac{1}{2} CD \\ &= \frac{1}{2} \times 8 = 4 \text{ cm} \end{aligned}$$

In $\triangle OAN$

$$OA^2 = ON^2 + AN^2$$

$$OA^2 = (7 - x)^2 + 3^2 \quad (\because MN = 7 \text{ cm, let } OM = x \text{ then } ON = 7 - x)$$

In $\triangle OCM$

$$OC^2 = OM^2 + CM^2$$

$$OC^2 = x^2 + 4^2$$

$\therefore OA = OC$ (Radii of the same circle)

$$\therefore OA^2 = OC^2$$

$$\text{So, } (7 - x)^2 + 3^2 = x^2 + 4^2$$

$$x^2 - 14x + 58 = x^2 + 16$$

$$-14x = 16 - 58$$

$$14x = 42$$

$$x = 3 \text{ cm}$$

So, radius of circle

$$OA^2 = (7 - x)^2 + 3^2$$

$$= (7 - 3)^2 + 3^2$$

$$= 16 + 9$$

$$= 25$$

$$OA = 5 \text{ cm}$$

Radius of circle $OA = 5 \text{ cm}$

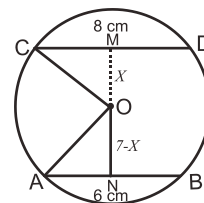

Figure - 40



Exercise - 2



- Two chords AB and AC of a circle are equal. Prove that center of circle lies on the bisector of $\angle BAC$.
- Two parallel chords which are 10 cm and 24 cm long respectively lie on opposite sides of center of a circle. The distance between chords is 17 cm . Find the diameter of circle.
- Centre of a circle is O and PO is the angle bisector of $\angle APD$ (see figure-41). Prove that $AB = CD$.
- O and C are centers of two circles whose radii are 13 cm and 3 cm respectively (see figure-42). If perpendicular bisector of OC meets on points A and B of the bigger circle then find the length of AB .
- Two equal chords AB and CD in a circle with center at O meet at right angle on point E . If P and Q are mid-points of chords AB and CD then prove that $OPEQ$ is a square.

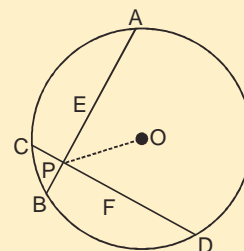

Figure - 41

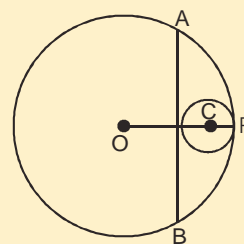

Figure - 42

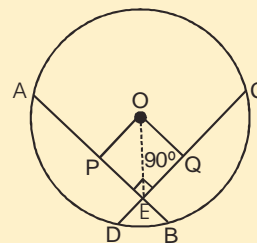

Figure - 43

Angle Subtended by Arc of a Circle at the Centre

If two points A and B lie on a circle then the circle is divided into two parts. Join the end point A and B of minor arc AB to the centre O . Angle $\angle AOB$ made by arc AB at the centre O is known as **central angle**. Again, take two points P and Q on the circle such that minor arc PQ made by them is greater than minor arc AB and makes an Angle $\angle POQ$ at the centre O (see figure-44). Can you see any relation between length of arc and angle subtended by arc at the centre? You can see in figure-44 that if the length of the arc is more, then angle subtended by it at the centre is also more.

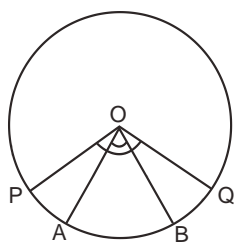

Figure - 44

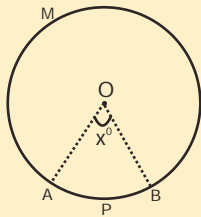

Figure - 45

If degree measure of angle of minor arc (figure-45) APB of a circle be x° then degree measure of major arc will be $(360^\circ - x^\circ)$. Why?



Think and Discuss

Join the end points of an arc of a circle to any point on the remaining circumference of the circle as shown in figure-46. Then $\angle ACB$ is the angle which is subtended by arc APB at any point on the remaining circumference of the circle.

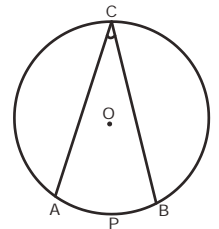

Figure - 46

Let us try to understand the relation between the angle subtended by an arc at the centre and that subtended on the remaining circumference of the circle.

Theorem - 7.

Statement : The angle subtended by an arc at the centre is double (twice) the angle subtended by it at any point on the remaining circumference of the circle.

Given : $\angle POQ$ subtended by an arc PQ at the centre of the circle and an angle $\angle PRQ$ at point R on the remaining circumference of the circle.

To Prove : $\angle POQ = 2\angle PRQ$

Construction : Join R to O and extend to point M.

Proof :

In $\triangle POR$

$$OP = OR \quad (\text{Radii of a circle})$$

$$\angle OPR = \angle ORP \quad (\text{Opposite angles on equal sides of a triangle are equal})$$

$$\angle POM = \angle OPR + \angle ORP \quad (\text{Exterior angles theorem})$$

$$\angle POM = 2\angle ORP \quad \dots\dots\dots(1)$$

In $\triangle QOR$

$$OQ = OR \quad (\text{Radii of a circle})$$

$$\angle OQR = \angle ORQ \quad (\text{Opposite angles on equal sides of a triangle})$$

$$\angle QOM = \angle ORQ + \angle OQR \quad (\text{Exterior angles theorem})$$

$$\angle QOM = 2\angle ORQ \quad \dots\dots\dots(2)$$

So, $\angle POM + \angle QOM = 2\angle ORP + 2\angle ORQ \quad \dots\dots\dots\text{on adding (1) and (2)}$

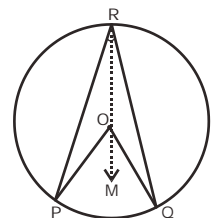

Figure - 47

$$\angle POQ = 2(\angle ORP + \angle ORQ)$$

$$\angle POQ = 2\angle PRQ$$

Let us consider a situation when arc is a semi-circle.

Theorem - 8.

Statement : Angle subtended by the diameter of a circle at a point on the circumference is a right angle.

Given : $\angle LNM$ is subtended by a chord on the circle.

To Prove : $\angle LNM = 90^\circ$

Proof : $\angle LOM = 180^\circ$ (Straight line)

$$\angle LOM = 2\angle LNM \quad (\text{By theorem-7})$$

$$\therefore 2\angle LNM = 180^\circ$$

$$\text{Or } \angle LNM = \frac{180^\circ}{2} = 90^\circ$$

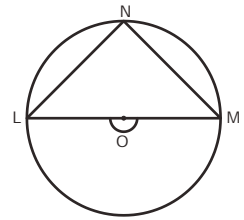

Figure - 48

So, we can say that angle subtended by the diameter at any point on the circumference is a right angle.

Example-9. In figure-49, O is centre of the circle and $\angle OPR = 30^\circ$ and $\angle OQR = 40^\circ$. Then find $\angle POQ$.

Solution : In $\triangle OPR$

$$OP = OR \quad (\text{Radii of a circle})$$

$$\therefore \angle OPR = \angle ORP = 30^\circ \quad (\text{Angles of isosceles triangle})$$

Similarly, in

$$\angle OQR = \angle ORQ = 40^\circ$$

$$\text{So, } \angle PRQ = \angle ORP + \angle ORQ \\ = 30^\circ + 40^\circ$$

$$\angle PRQ = 70^\circ$$

$$\therefore \angle POQ = 2\angle PRQ \quad (\text{Angle subtended on centre is twice the angle subtended on remaining segment})$$

$$\angle POQ = 2 \times 70^\circ = 140^\circ$$

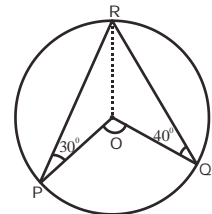

Figure - 49

Example-10. In figure-50, AB is diameter and O is centre of given circle. If $\angle OAP = 50^\circ$ then find $\angle OPB$.

Solution :In $\triangle AOP$ $OA = OP$

(Radii of the same circle)

$$\therefore \angle OAP = \angle OPA = 50^\circ$$

$$\angle APB = 90^\circ$$

(Angle subtended by diameter)

$$\text{So, } \angle APB = \angle OPA + \angle OPB$$

$$90^\circ = 50^\circ + \angle OPB$$

$$\therefore \angle OPB = 40^\circ$$

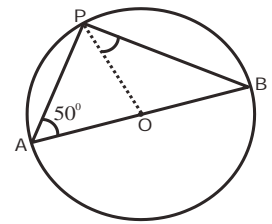
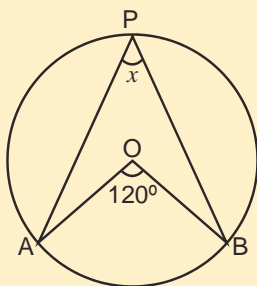
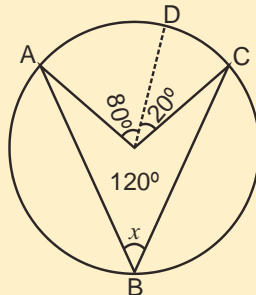
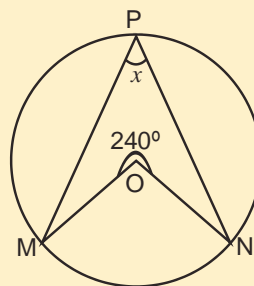
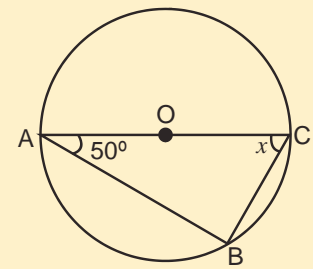
**Figure - 50****Try These**Find the value of x in given figures-**Figure - 51****Figure - 52****Figure - 53****Figure - 54**

Let us see the relation between angles which are present in the same segment of a circle.

Theorem - 9.**Statement :** Angles in the same segment of a circle are equal.**Given :** $\angle ACB$ and $\angle ADB$ which are in the same segment of circle where O is the centre.**To Prove :** $\angle ACB = \angle ADB$ **Proof :** $\angle AOB = 2\angle ACB$ (Since the angle subtended by an arc at the centre is double the angle subtended by it at any point on the remaining part of the circle.)

$$\angle AOB = 2\angle ADB$$

$$\text{So, } 2\angle ACB = 2\angle ADB$$

$$\angle ACB = \angle ADB$$

So, we can say that which are in same segment of a circle are equal.

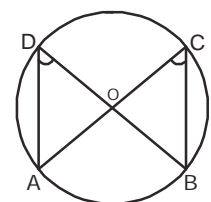
**Figure - 55**

Try These



Find the value of x and y in given figures-

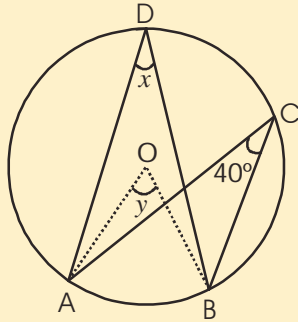

Figure - 56

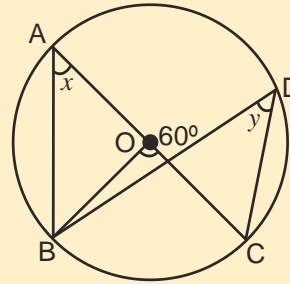

Figure - 57

Example-11. In figure-58, $\angle CAB = 25^\circ$ and $\angle ADB = 35^\circ$. Then find $\angle ABC$.

Solution : Here in figure

$$\angle ADB = \angle ACB \text{ (Angle in same segment)}$$

$$\therefore \angle ACB = 35^\circ$$

In $\triangle ABC$

$$\angle ABC + \angle ACB + \angle CAB = 180^\circ$$

$$\angle ABC + 35^\circ + 25^\circ = 180^\circ$$

$$\angle ABC = 180^\circ - 60^\circ$$

$$\angle ABC = 120^\circ$$

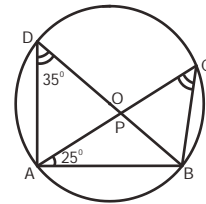

Figure - 58

Example-12. Prove that the circle drawn on any one of the equal sides of an isosceles triangle as diameter bisects the base.

Solution : $\triangle ABC$ in which $AB = AC$ and a circle is drawn by taking AB as diameter which intersects the side BC of triangle at D .

Since angle in a semi-circle is a right angle.

$$\therefore \angle ADB = 90^\circ$$

$$\text{But, } \angle ADB + \angle ADC = 180^\circ$$

$$90^\circ + \angle ADC = 180^\circ$$

$$\angle ADC = 90^\circ$$

In $\triangle ADB$ and $\triangle ADC$

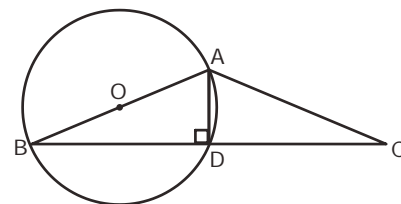

Figure - 59

$$\begin{aligned}
 AB &= AC && \text{(Given)} \\
 AD &= AD && \text{(Common side)} \\
 \text{And } \angle ADB &= \angle ADC = 90^\circ \\
 \therefore \triangle ADB &\cong \triangle ADC && \text{(By RHS congruence)} \\
 BD &= DC
 \end{aligned}$$

Exercise-3

1. In figure-60, O is centre of circle, PQ is a chord. If $\angle PRQ = 50^\circ$ then find $\angle OPQ$.

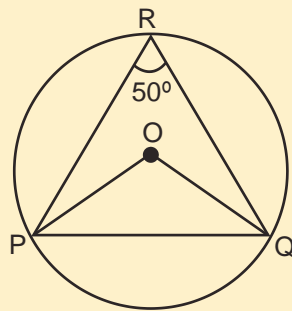

Figure - 60

2. In figure, find the value $\angle PBO$ if $\angle AOB = 50^\circ$ and $\angle PQB = 75^\circ$.

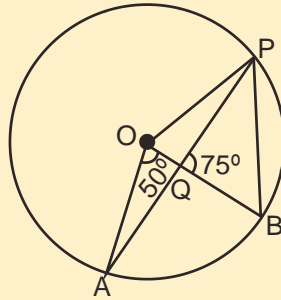

Figure - 61

3. If O is the centre of circle, find the value of x in figure.

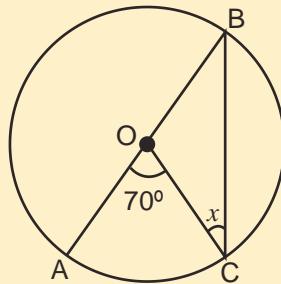

Figure - 62



4. If O is the centre of circle, find the value of x .

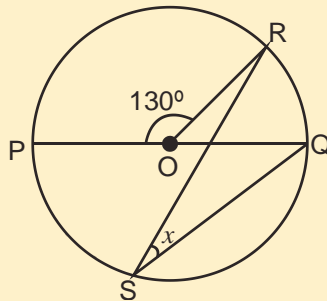

Figure - 63

5. If O is the centre of circle, then find the value of x in given figure.

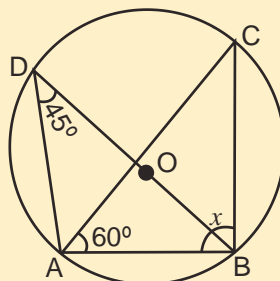

Figure - 64

6. Find the value of $\angle ABC$ in figure.

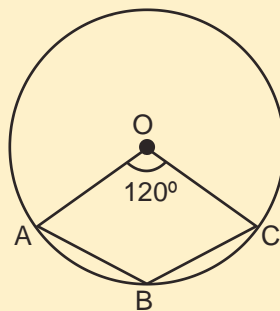

Figure - 65

7. Find the value of x in figure and prove that $AD \parallel BC$

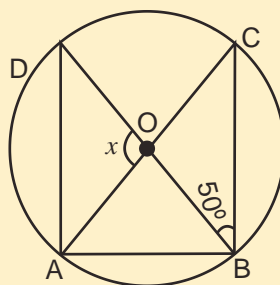

Figure - 66

8. In figure, O is centre of circle and $OD \perp AB$ if $OD=5\text{ cm}$ then find the value of AC.

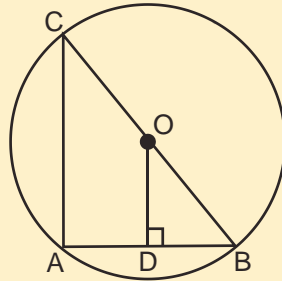

Figure - 67

Cyclic Quadrilateral

We saw that one and only one circle can be drawn through three non-collinear points. Can we draw a circle passing through four non-collinear points (of which no three are collinear)? If we draw a circle through three non-collinear points P, Q, R then the position of the fourth point S can be as follows (figure-68).

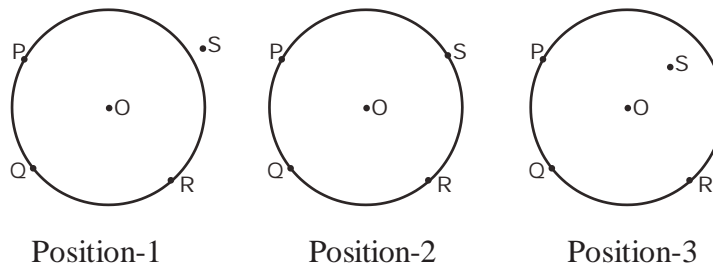

Figure - 68

In position – 1, the point S is located outside the circle, in position – 2 it is located on the circle and in position – 3 it is located within the circle. Therefore, we can say that if we take 4 non-collinear points then it is possible for a circle to pass through them and it is also possible that all four do not lie on the circle.

In figure – 68, if we join P, Q, R and S we obtain a quadrilateral (see figure – 69).

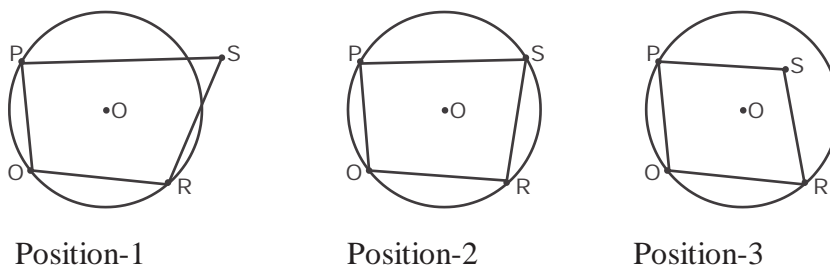

Figure - 69

All four vertices of the quadrilateral obtained in position – 2 are located on the circle. If all four vertices of a quadrilateral are located on a circle, it is known as cyclic circle. Does this quadrilateral have any special property not seen in other quadrilaterals?



Try These

Draw a circle of any radius. Take any four points on the circle and use them to form a quadrilateral. Measure the pairs of opposite angles and find their sum.

You will find that the sum of opposite angles of any quadrilateral whose 4 vertices lie on a circle is 180° .

We will now try to find the logical proof of the above statement.

Theorem - 10.

Statement : The sum of either pair of opposite angles of a cyclic quadrilateral is 180° .

Given : A cyclic quadrilateral ABCD.

To Prove : $\angle A + \angle C = \angle B + \angle D = 180^\circ$

Construction : Join A and C to O.

Proof : We know the relation between the angle subtended by arc ABC at centre and at any point on remaining part of circle.

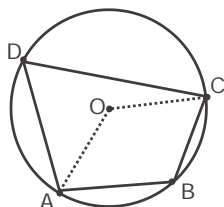

Figure - 70

Angle subtended by arc ABC at the center $\angle AOC = 2\angle ADC$ (i)

Angle subtended by arc CDA at the center $\angle COA = 2\angle ABC$ (ii)

So, $\angle AOC + \angle COA = 2(\angle ADC + \angle ABC)$

$$360^\circ = 2(\angle D + \angle B)$$

$$\angle B + \angle D = \frac{360^\circ}{2}$$

$$\angle B + \angle D = 180^\circ$$

In quadrilateral ABCD,

$$\angle A + \angle C + \angle B + \angle D = 360^\circ$$

$$\angle A + \angle C + 180^\circ = 360^\circ$$

$$\angle A + \angle C = 180^\circ$$

So, we can say that the sum of either pair of opposite angles of a cyclic quadrilateral is 180° . Is converse of this theorem true as well? Yes, if the sum of any pair of opposite angles of a quadrilateral is 180° , then the quadrilateral is cyclic, that is, we can draw a circle passing through all four vertices of this quadrilateral.

Example-13. Find the value of x in figure-71.

Solution : $\angle A + \angle C = 180^\circ$ (Sum of opposite angles of cyclic quadrilateral is 180°)

$$x + 60^\circ = 180^\circ$$

$$x = 120^\circ$$

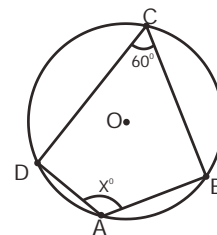

Figure - 71

Example-14. Find the value of x in figure-72.

Solution : $\angle ABD = 90^\circ$ (Angle subtended by diameter on any point on the circle)

$$\angle ABD + \angle BDA + \angle DAB = 180^\circ$$

$$90^\circ + 30^\circ + \angle DAB = 180^\circ$$

$$\angle DAB = 180^\circ - 120^\circ$$

$$\angle DAB = 60^\circ$$

$\angle DCB + \angle DAB = 180^\circ$ (Sum of opposite angles of cyclic quadrilateral)

$$x + 60^\circ = 180^\circ$$

$$x = 120^\circ$$

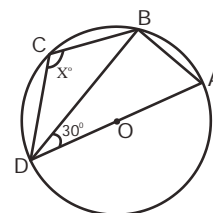

Figure - 72

Example-15. P is a point on the side BC of a triangle ABC such that $AB = AP$. Through A and C, lines are drawn parallel to BC and PA respectively, so as to intersect at D (as shown in figure-73). Show that ABCD is a cyclic quadrilateral.

Solution : In $\triangle ABP$

$$AB = AP \quad (\text{Given})$$

Thus, $\angle ABP = \angle APB$

(Opposite angles of equal sides)

$$AP \parallel CD \text{ तथा } AD \parallel BC \quad (\text{Given})$$

So, APCD is a parallelogram.

$$\angle APC = \angle ADC$$

(Opposite angles of a parallelogram)

Since $\angle APB + \angle APC = 180^\circ$ (Linear pair axiom)

$$\angle ABP + \angle ADC = 180^\circ \quad (\angle APB = \angle ABP \text{ and } \angle APC = \angle ADC)$$

If the sum of either pair of opposite angles of a quadrilateral is 180° then the quadrilateral is cyclic.

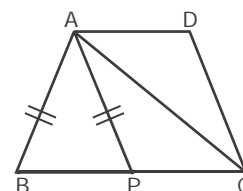

Figure - 73

Exercise - 4



1. $AB \parallel CD$ in given figure. If $\angle DAB = 80^\circ$ then find the remaining interior angles of the quadrilateral.

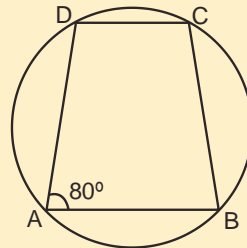

Figure - 74

2. Find $\angle QRS$ and $\angle QTS$ in the given figure.

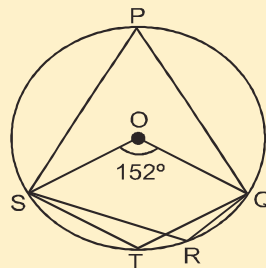

Figure - 75

3. ABCD is a cyclic quadrilateral in given figure whose side AB is diameter of the circle. If $\angle ADC = 150^\circ$ then find $\angle BAC$.

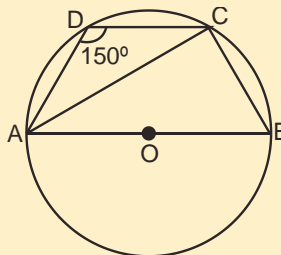

Figure - 76

4. Find the value of x in given figure.

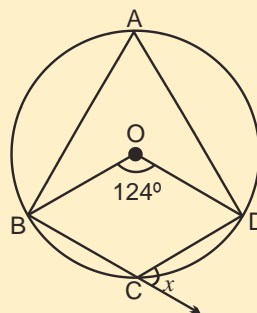

Figure - 77

5. PQ and RS are two parallel chords of a circle and lines RP and SQ intersect at point M (See figure-78). Prove that $MP = MQ$.

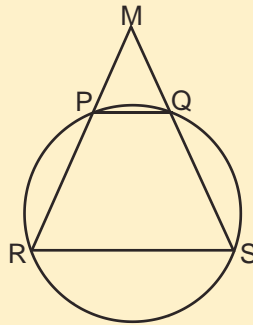

Figure - 78

6. PQ is diameter of semi-circle in given figure. If $\angle PQR = 60^\circ$ and $\angle SPR = 40^\circ$ then find the value of $\angle QPR$ and $\angle PRS$.

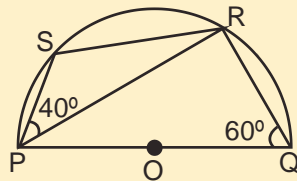

Figure - 79

7. If diagonals of a cyclic quadrilateral are diameters of the circle, then prove that the quadrilateral is a rectangle.
8. In figure-80 PQRS is a quadrilateral. If $\angle P = \angle QRY$ then prove that PQRS is cyclic quadrilateral.

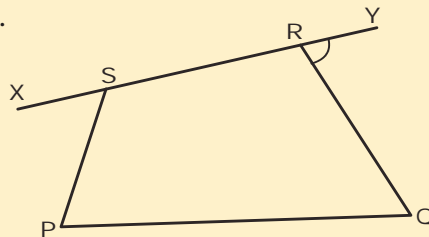

Figure - 80

9. If two non-parallel sides of a trapezium are equal, then prove that it is cyclic quadrilateral.

Tangents and Secant of a Circle

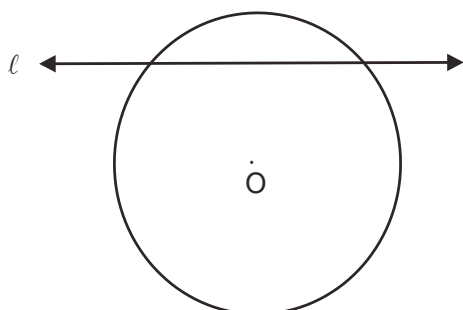

Figure - 81

Draw a circle and a line on paper as shown in figure-81. Now draw some lines parallel to l .

There are two common points A and B between line m and circle in given figure-82.

In the same way between line l and the circle there are two common points C and D. There is only one point E common between line n and the circle and there are no common points between line p and the circle.

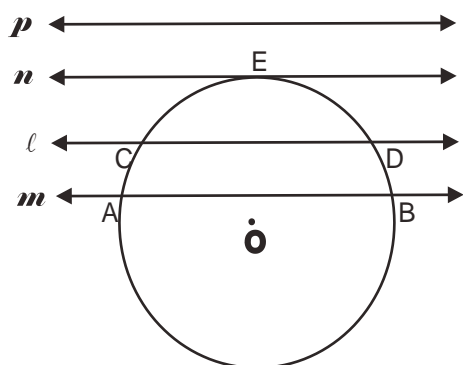

Figure - 82

We find that a line can be in three different positions relative to a circle.

In figure-83(i), line l does not intersect the circle so there are no common points between the line and the circle.

If figure-83(ii) line l intersects the circle at two different points so there are two common points P and Q between the line and the circle.

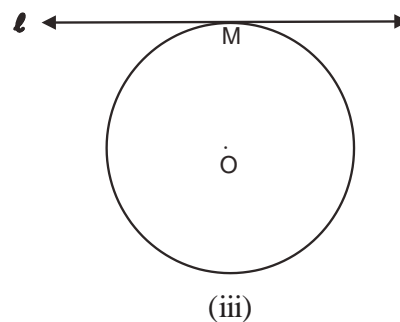
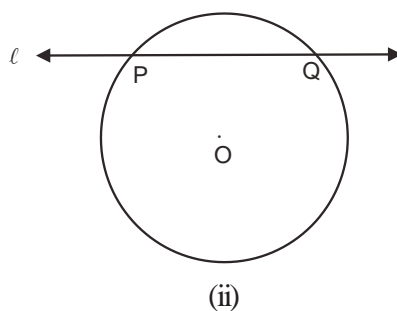
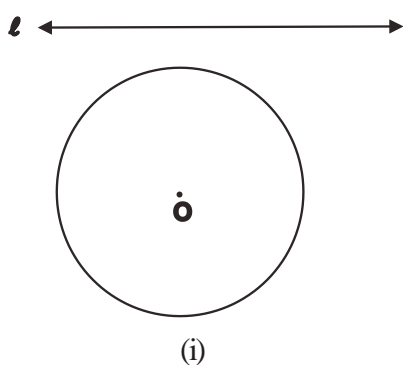

Figure - 83

In figure-83(iii) line l touches the circle at only one point so there is only one point M which is common to the line and the circle. In this situation, we say that l is tangent of circle and common point M is tangent point.

In figure-84 line l is intersecting the circle at two points P and Q. On keeping line l fixed at point P and rotating it in any direction continuously (see Q_1, Q_2, Q_3, \dots) we will reach a condition where intersecting point Q becomes coincident with point P. In this case, we can call secant line as tangent to circle at point P and P as tangent contact point.

The tangent to a circle is a special case of the secant, when the two end points of its corresponding chord coincide. Thus, tangent to a circle is that line which touches the circle at one point.

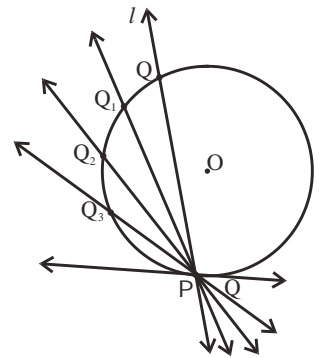

Figure - 84

Think and Discuss

Only one tangent can be drawn at any particular point on a circle. Why?



Try These

Identify and write the names in your notebook of intersecting lines, secants and tangents in the following figure.

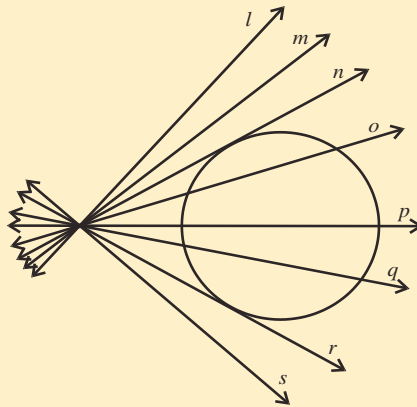

Figure - 85



Tangent line and radius passing through tangent contact point

The distance between a point and a line (when point is not on the line) is least when it is perpendicular. Will the distance from tangent to the centre be minimum, that is, is the radius passing through tangent point perpendicular at contact point?

Theorem - 11.

A radius of a circle meeting the contact point of tangent to the circle is perpendicular to the tangent.

Known : A circle with centre at O and having tangent AB meeting the circle at contact point, P.

To Prove : $OP \perp AB$

Construction : Take point P on AB. Also take points Q, R, S on AB. Join all four points to the centre of the circle O.

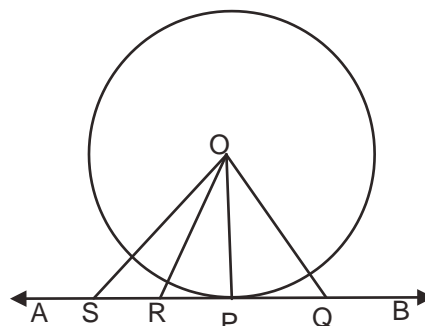

Figure - 86

Proof : In figure-86 we can see that points Q, R and S are located outside the circle and we know that distance between a point located outside the circle and the centre is more than the radius. Therefore, length of OP is least among OQ, OR and OS. Therefore, of all points on tangent AB, contact point P is at the least distance from the centre of the circle.

$$\therefore OP \perp AB$$

We use this fact to draw the tangent at any point on the circle when we know the centre of the circle.

How many tangents through a point located outside the circle

Take a point P outside the circle. Try to draw tangents to the circle passing through external point P (see figure – 87). You will find that two and only two tangents can be drawn on the circle from a point outside the circle. The distance between the external point P and the contact point of the tangent

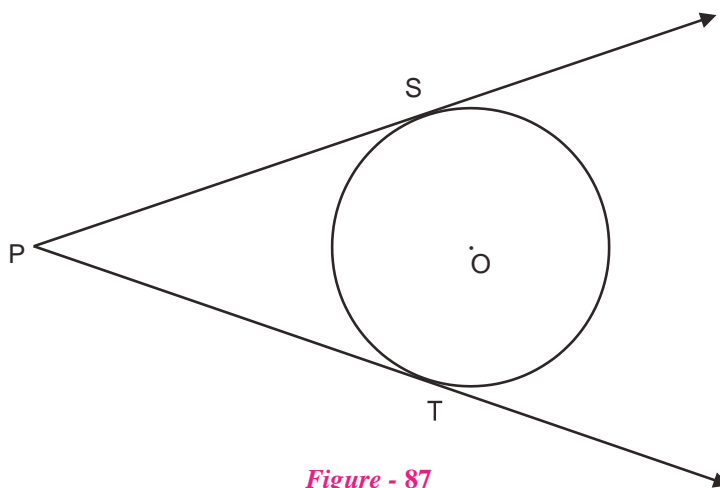

Figure - 87

is known as length of the tangent. See figure – 87 and try to find some relation between PS and PT. Measure the lengths of PS and PT. You will find that $PS = PT$. Let us see the proof for this statement.

Theorem - 12.

The lengths of tangents drawn from an external point to a circle are equal.

Known : AP and AQ are two tangent segments to a circle drawn from the same external point A.

To Prove : $AP = AQ$

Construction : Join A, P, Q to the centre of the circle O.

Proof : In $\triangle OPA$ and $\triangle OQA$

$$OP = OQ$$

(radii of the same circle)

$$OA = OA \quad (\text{common side})$$

$$\angle APO = \angle AQO = 90^\circ \quad (\text{radii passing through contact points are perpendicular to the tangent})$$

$$\triangle OPA \cong \triangle OQA \quad (\text{angle-side congruency in right angle triangles})$$

Thus, $AP = AQ$ (corresponding sides of congruent triangles)

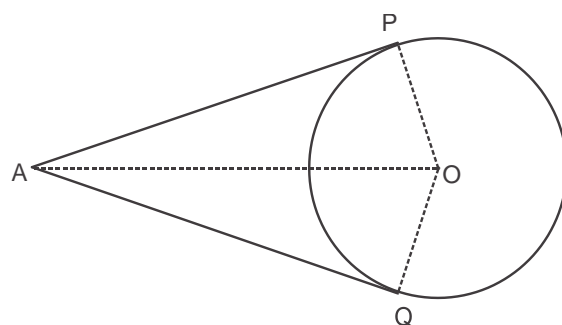

Figure - 88

In the proof of the above theorem, $\triangle OPA \cong \triangle OQA$ thus $\angle OAP = \angle OAQ$. We can say that the centre of the circle is located on the angle bisector of $\angle PAQ$. We can use this information to draw a circle which touches two intersecting lines. Especially, we can draw a circle that touches the three sides of a given triangle. The circle is known as incircle of the triangle and its centre is known as the incentre.

Example-16. In figure – 89, $OP = 13$ cm and the radius of the circle is 5 cm. Find the lengths of tangents PT and PS drawn on the circle from point P.

Solution : In $\triangle OPT$

$$\angle OTP = 90^\circ$$

In right angle triangle $\triangle OPT$

$$OP^2 = OT^2 + PT^2$$

$$\text{Or } 13^2 = 5^2 + PT^2$$

$$\text{Or } PT^2 = 13^2 - 5^2$$

$$PT^2 = 169 - 25$$

$$PT^2 = 144$$

$$PT = 12 \text{ cm}$$

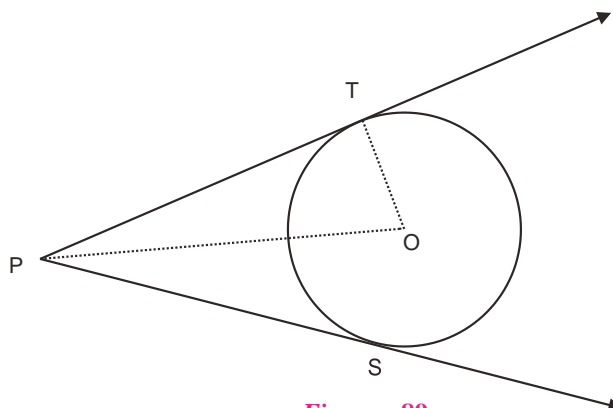

Figure - 89

We know that,

$$PS = PT$$

Thus, $PS = 12 \text{ cm}$

Thus, tangent $PT = PS = 12 \text{ cm}$

Example-17. In figure – 90, O is centre of the circle and PA and PB are tangents. If $\angle APB = 60^\circ$ then find $\angle AOB$.

Solution : In quadrilateral AOPB

$$\angle OAP = \angle OBP = 90^\circ$$

$$\text{And } \angle OAP + \angle APB + \angle PBO + \angle AOB = 360^\circ$$

$$90^\circ + 60^\circ + 90^\circ + \angle AOB = 360^\circ$$

$$240^\circ + \angle AOB = 360^\circ$$

$$\angle AOB = 360^\circ - 240^\circ$$

$$\angle AOB = 120^\circ$$

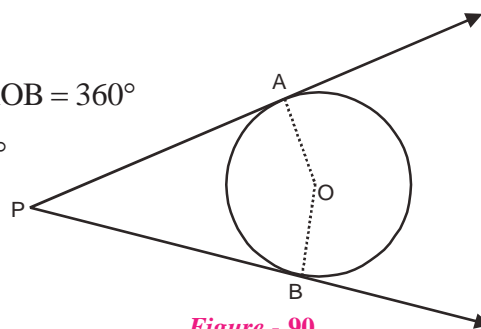

Figure - 90

Example-18. In figure-91, P, Q and R are points external to a circle with its centre at O. The lengths of tangents PA, QB and RC are 3 cm, 4 cm and 5 cm respectively. Find the perimeter of $\triangle PQR$.

Solution : We know that lengths of tangent segments drawn from the same external point are equal.

$$\begin{aligned} \therefore \quad PC &= PA = 3 \text{ cm} \\ QA &= QB = 4 \text{ cm} \\ RB &= RC = 5 \text{ cm} \\ PQ &= PA + AQ \\ PQ &= 3 + 4 = 7 \text{ cm} \\ QR &= QB + BR \\ QR &= 4 + 5 = 9 \text{ cm} \\ PR &= PC + CR \\ PR &= 3 + 5 = 8 \text{ cm} \end{aligned}$$

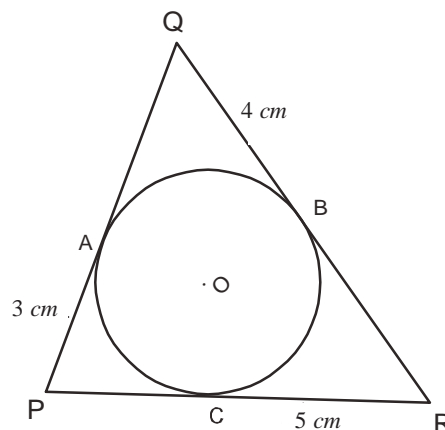

Figure - 91

Thus, perimeter of $\triangle PQR = PQ + QR + PR$

$$= 7 + 9 + 8 \text{ cm}$$

$$= 24 \text{ cm}$$

Example-19. Tangents TP and TQ are two tangents drawn from external point T on the circle with the centre at O. Prove that $\angle PTQ = 2\angle OPQ$.

Solution : Assume that $\angle PTQ = \theta$

$$TP = TQ \quad (\text{from theorem-12})$$

Thus, $\triangle TPQ$ is an isosceles triangle where

$$\angle TPQ + \angle TQP = 180^\circ - \theta$$

$$\therefore \angle TPQ = \angle TQP = \frac{1}{2}(180^\circ - \theta)$$

$$\angle TPQ = 90^\circ - \frac{1}{2}\theta$$

$$\therefore \angle OPT = 90^\circ \quad (\text{from theorem-11})$$

$$\angle OPQ = \angle OPT - \angle TPQ$$

$$= 90^\circ - \left(90^\circ - \frac{1}{2}\theta\right)$$

$$= \frac{1}{2}\theta$$

$$= \frac{1}{2}\angle PTQ$$

Thus, $\angle PTQ = 2\angle OPQ$ Hence Proved.

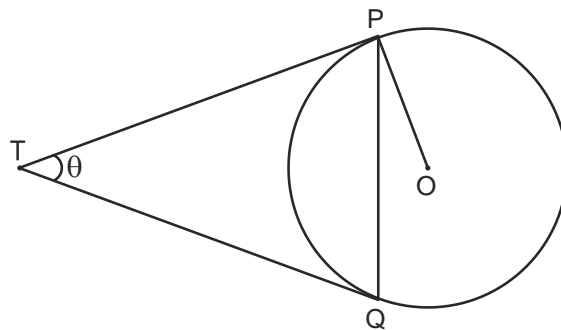

Figure - 92



Segments of a Chord

PQ is a chord and R is a point on the chord located inside the circle. It is said that R internally divides the chord PQ into two segments PR and RQ. Similarly, if S is a point on line PQ located outside the circle then S is said to externally divide the chord into two segments SP and SQ.

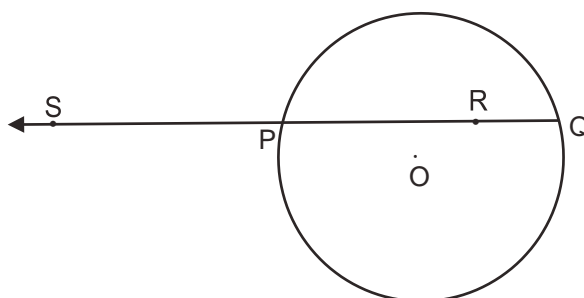

Figure - 93

Relation between tangent and secant

We have already seen the relation between two tangents drawn from the same external point. Is there any relation between the tangent and secant passing through the same external point?

Theorem - 13.

Statement : If PAB is a secant to a circle which intersects the circle at A and B and PT is a tangent to the circle then $PA \times PB = PT^2$

Given : Secant to the circle which intersects the circle at A and B and tangent PT to the circle.

To Prove : $PA \times PB = PT^2$

Construction : Draw OL perpendicular to AB. Join OP, OT and OA.

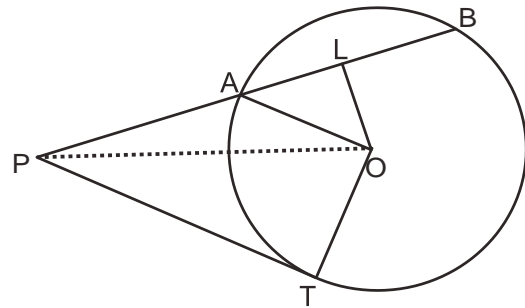

Figure - 94

Proof : $PA \times PB = (PL - AL)(PL + LB)$

$$= (PL - AL)(PL + AL)$$

(Perpendicular to a chord from the centre of the circle divides it into two equal parts)

$$= PL^2 - AL^2$$

$$= PL^2 - (OA^2 - OL^2) \quad (\text{From Pythagoras theorem})$$

$$= PL^2 - OA^2 + OL^2$$

$$= PL^2 + OL^2 - OA^2 \quad (\text{from Pythagoras theorem in triangle } \triangle OPL)$$

$$= OP^2 - OA^2$$

$$= OP^2 - OT^2 \quad (OA = OT = \text{radii})$$

$$= PT^2 \quad (\text{from Pythagoras theorem})$$

$$\therefore PA \times PB = PT^2$$

Do This

If two chords of the same circle intersect each other internally or externally then the product of the segments of any one of the chords is equal to the product of the segments of the chord. That is, $PA \times PB = PC \times PD$.

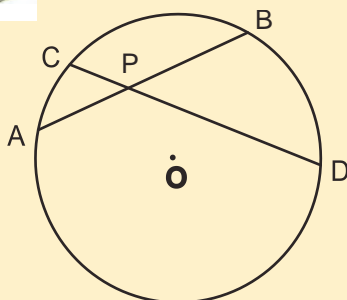

Figure - 95

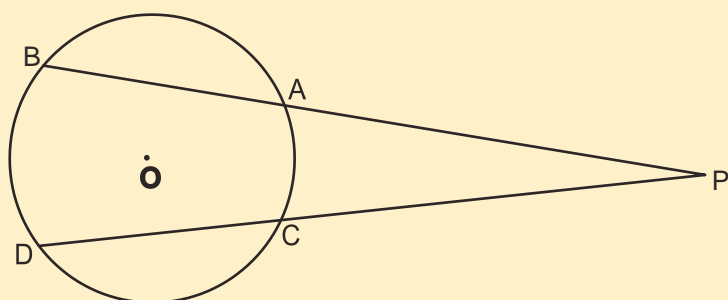

Figure - 96

Example-20. Let AB and CD be two chords of the circle, which intersect each other internally at point P. If $PA = 2\text{ cm}$, $PB = 3\text{ cm}$ and $PC = 4\text{ cm}$ then find the length of PD.

Solution : Given,

$$PA = 2\text{ cm}, PB = 3\text{ cm}, \text{ तथा } PC = 4\text{ cm},$$

$$\text{Let } PD = x\text{ cm}$$

$$\text{We know that } PA \times PB = PC \times PD$$

$$2 \times 3 = 4 \times x$$

$$x = \frac{6}{4}$$

$$x = 1.5\text{ cm}$$

$$PD = 1.5\text{ cm}$$

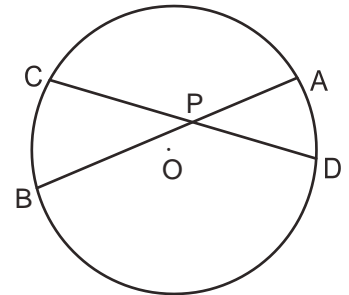

Figure - 97

Example-21. Chords PQ and RS intersect each other at point M which lies outside the circle. If $MQ = 3\text{ cm}$, $MP = 8\text{ cm}$ and $MS = 4\text{ cm}$ then find the lengths of MR and RS.

Solution : Given, $MQ = 3\text{ cm}$, $MP = 8\text{ cm}$ and $MS = 4\text{ cm}$

Assume that $MR = x\text{ cm}$

$$\text{We know that : } MQ \times MP = MS \times MR$$

$$3 \times 8 = 4 \times MR$$

$$MR = \frac{24}{4}$$

$$MR = 6\text{ cm}$$

$$\text{Chord } RS = MR - MS$$

$$= 6 - 4$$

$$\text{Chord } = 2\text{ cm}$$

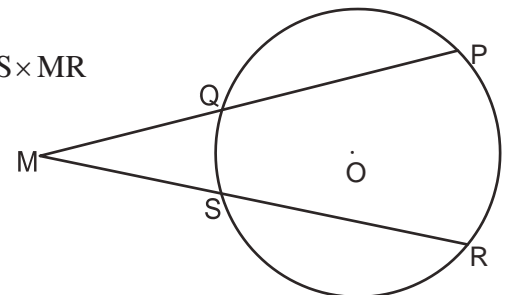

Figure - 98

Example-22. In figure – 99, if $PA = 4\text{ cm}$ and $PB = 9\text{ cm}$ then find the length of PT.

Solution : We know that $PA \times PB = PT^2$

$$4 \times 9 = PT^2$$

$$PT^2 = 36$$

$$PT = 6\text{ cm}$$

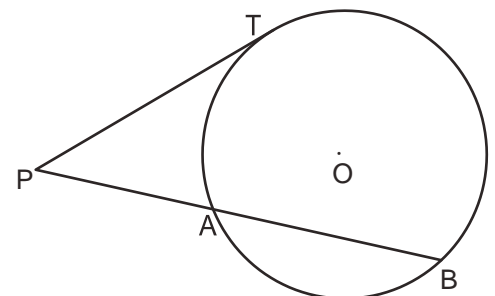

Figure - 99

Angle made by a chord and a tangent

Suppose we are given a circle with its centre at O and AB is a tangent at point P on the circle. Draw chord PQ from P. Take R on the major arc of the circle.

Major arc PRQ is called the alternate segment of the segment made by the chord PQ.

In figure - 100, if $\angle QPB = x^\circ$ then $\angle OPQ = 90^\circ - x^\circ$ (Why?)

$$\angle OPQ = \angle OQP = 90^\circ - x^\circ \quad (\because OP = OQ = \text{radius})$$

In $\triangle POQ$

$$\begin{aligned} \angle POQ &= 180^\circ - [(90^\circ - x^\circ) + (90^\circ - x^\circ)] \\ &= 180^\circ - [180^\circ - 2x^\circ] \\ &= 2x^\circ \\ \angle PRQ &= \frac{1}{2} \angle POQ \\ &= \frac{1}{2} \times 2x^\circ \\ &= x^\circ \end{aligned}$$

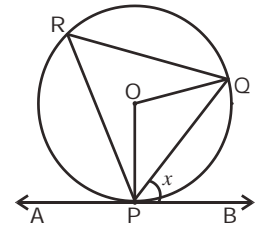

Figure - 100

Thus, we can say that “the angle between a tangent and chord at the contact point is equal to the angle made by that chord in the alternate segment.”

This is also a theorem which is used to draw the tangent when we do not know the centre of the circle.

Example-23. In figure -101 PQ is tangent to the circle. If AOB is diameter of the circle and $\angle SAB = 50^\circ$ then find $\angle ASP$.

Solution : $\angle BSQ = \angle SAB = 50^\circ$
 (from result of alternate segment)
 $\angle ASB = 90^\circ$
 (angle formed by the diameter)
 $\angle ABS + \angle ASB + \angle BAS = 180^\circ$
 $\angle ABS + 90^\circ + 50^\circ = 180^\circ$
 $\angle ABS = 40^\circ$
 $\therefore \angle ASP = \angle ABS$
 (from result of alternate segment)
 $\therefore \angle ASP = 40^\circ$

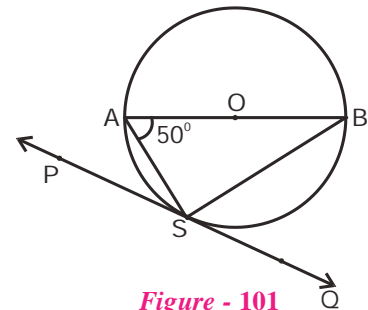

Figure - 101



Example-24. Tangent MN touches the circle at point P. Chord PQ is such that $\angle QPN = 52^\circ$. Find $\angle POQ$ when O is the centre of the circle.

Solution : Let R be a point on the circumference of the circle. Join centre O to points P and Q. Similarly, join R to P and Q.

$\angle QPN = \angle PRQ = 52^\circ$ (Since, the angle between a tangent and chord at the contact point is equal to the angle made by that chord in the alternate segment)

$\angle POQ = 2\angle PRQ$ (Angle at the centre is twice the angle formed on the circumference)

$$\angle POQ = 2 \times 52^\circ$$

$$\angle POQ = 104^\circ$$

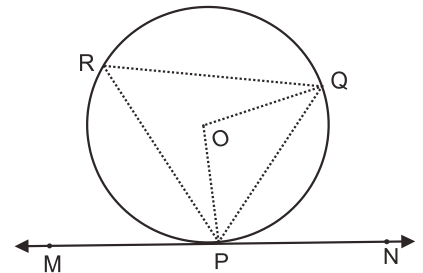

Figure - 102

Exercise 5

- From a point P, which is at a distance of 10 cm from the centre of the circle, the length of tangent segment is 8 cm. Find the radius of the circle.



- In figure – 103, $\angle POQ = 100^\circ$, AP and AQ are tangents. Find the value of $\angle PAO$.

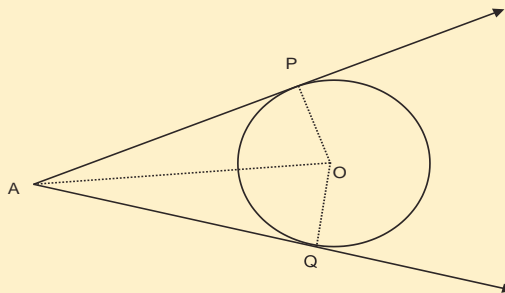

Figure - 103

3. Prove that the tangents drawn at the endpoints of a diameter of a circle are parallel to each other.
4. A circle touches all sides of quadrilateral ABCD. Prove that $AB + CD = BC + DA$.
5. Prove that the angle between two tangents drawn from the same external point is supplementary to the angle subtended at the centre by the chord which is formed by joining the contact points of the tangents.
6. Prove that the intercept of a tangent between two parallel tangents to a circle subtends a right angle at the centre.

What We Have Learnt



1. The set of all points on a plane which are equidistant from a given point is called circle.
2. Two equal chords in a circle subtend equal angles at the centre.
3. If the angles subtended by two chords at the center of a circle are equal then the chords are equal.
4. A perpendicular dropped from the centre of a circle on a chord bisects the chord.
5. The bisector from the centre of a circle on a chord is perpendicular to the chord.
6. One and only one circle can be drawn passing through three non-collinear points.
7. Two equal chords in a circle are equidistant from the centre.
8. The angle subtended by an arc at the centre is twice the angle subtended by the same arc at any other point on the circumference.
9. The angle subtended by the diameter on any point on the circumference is a right angle.
10. Angles in the same segment of a circle are equal to each other.
11. In a cyclic quadrilateral, the sum of any opposite pair of angles is equal to 180° .

12. If the sum of any pair of opposite angles of a quadrilateral is equal to 180° , then the quadrilateral is cyclic.
13. The radius drawn from a tangent is perpendicular to the tangent.
14. The length of tangents to a circle drawn from the same external point is equal.
15. The angle between a tangent and chord at the contact point is equal to the angle made by that chord in the alternate segment

ANSWER KEY

Exercise - 1

1. (i) 10 cm (ii) 24 cm
2. (i) 5 cm (ii) 25 cm
3. 8 cm 4. 15 cm

Exercise - 2

2. 26 cm 4. 24 cm

Exercise - 3

1. 40° 2. 80°
3. 35° 4. 25°
5. 75° 6. 120°
7. 80° 8. 10 cm

Exercise - 4

1. $\angle DCB = 100^\circ$, $\angle ABC = 80^\circ$, $\angle ADC = 100^\circ$
2. $\angle QRS = 104^\circ$, $\angle QTS = 104^\circ$
3. $\angle BAC = 60^\circ$
4. 62°
6. $\angle QPR = 30^\circ$, $\angle PRS = 20^\circ$

Exercise - 5

1. 6 cm
2. 40°



GEOMETRICAL CONSTRUCTIONS

CHAPTER

13

Introduction

Geometrical construction implies drawing geometrical figures with the help of compass and ruler using exact measurements. Geometrical constructions help us experience and think about many geometrical concepts, relations and proofs. In this chapter, by applying geometrical concepts we will construct many geometrical shapes which we have studied in previous years. Along with constructions, we will also analyze them so that we can understand how these constructions take place and why. To do so, while drawing the constructions according to the given problem, we will think about and discuss the different figures.

In mathematics, problems are solved keeping in mind logic and proof. Solving problems and observing whether it can be solved by more than one method; thinking which method is useful and easy; raising and thinking about such questions helps to build our logical and critical thinking ability.

Let us do some constructions.

Construction-1: To Construct a Similar Angle

An angle is given and we have to construct another angle of equal value. What should we do? In one method, we can measure the angle with the help of a protractor and then construct an angle which is equal to it. But, if we do not have any instrument to measure the angle, then what can we do? Let us see-

So far, we have made line-segments and angles of given measurements with the help of ruler or protractor. In this chapter, we will also learn how to use a compass during geometrical constructions.

Using ruler/scale in geometrical constructions: We know that given any two points A and B, only one straight line is possible such that it passes through A and B (axiom). We can use the ruler to draw a line AB or line segment AB or the ray AB.

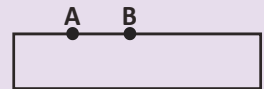

Using compass in Constructions: We know from the definition of a circle that given a fixed point and fixed radius, only one circle can be drawn. Here, we will use the compass to draw a circle or an arc.

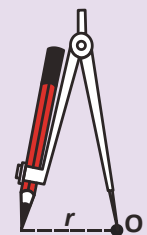

Step-1. Before begin our construction, it will be helpful to think on the following questions:-

1. What information is given in the question, how to solve it and which of the given information is useful?

An angle is given and we have to construct another angle which is equal to it.

If the angle is $\angle ABC$, then we have to construct another angle $\angle RPQ$ such that $\angle RPQ = \angle ABC$.

2. Based on the given information, which geometrical concepts can be used during the construction?

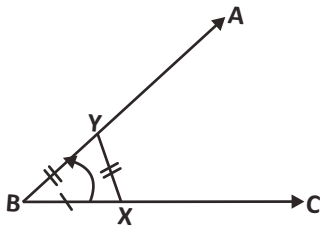

Figure - 1

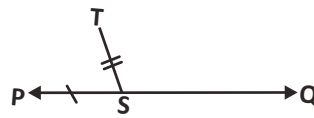

Figure - 2

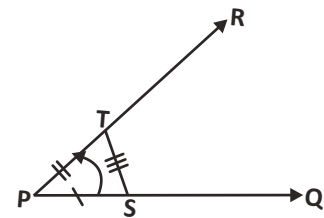

Figure - 3

We know that if we rotate a ray from one position to another position then the measure of that rotation is known as angle. By rotating a ray BC to BA , we get angle ABC (Figure-1).

Suppose we construct a ray PQ and then rotate it equal to the rotation of BC to BA . But how do we do this?

Let us take two points X and Y on BC and BA respectively such that $BX=BY$ and consider a point S , on PQ , such that $BX=PS$ (Figure-2).

Now, if we consider a point (say T) such that the location of T with respect to P and S corresponds to the position of Y relative to B and X then the ray PT is congruent to BY (figure-3).

This point T , on the radius of the arc PS , will be located at a distance XY from S . If we draw a ray PR joining PT then $\angle TPS$ is equal to angle $\angle YBX$ (Or $\angle ABC$).

Step -2. After drawing the rough figure, geometrical construction can be done in a step by step manner.

Steps of construction:-

1. Consider a point P and draw a ray PQ from point P; this ray is one side of the new angle.
2. Now, in given angle ABC draw an arc of any measure from the vertex B which intersects BA at J and BC at K (see figure-4).
3. Now we draw an arc of same measure from point P which intersects ray PQ at M (Figure-5).
4. Now measure distance KJ from point K and cut an arc of the same length from point M intersecting the first arc. Let the intersection point be L.
5. Now draw ray PR joining P to L.
 $\angle RPQ$ is the required angle.
 $\angle RPQ = \angle ABC$

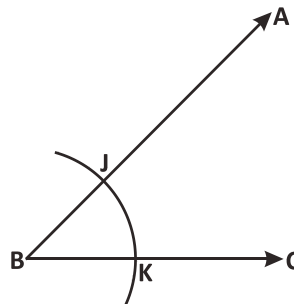

Figure - 4

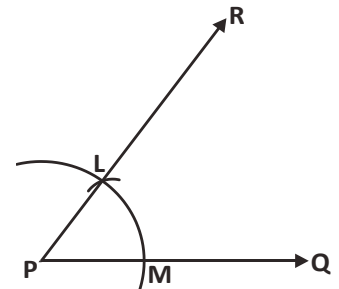

Figure - 5

Step-3. Checking the constructed figure- We can check whether the constructed figure is the same as per the information given in the problem. In addition to measurement, we can also check through proofs.

Let us see whether the constructed angle is equal to the obtained angle or not.

For this, we can construct triangles by using the angles from both the figures as references. Join M to L and K to J so that triangles PML and BKJ are formed.

If we look at triangles PML and BKJ then we find that –

$PM = BK$ (from construction)

$ML = KJ$ (from construction)

$PL = BJ$ (from construction)

Therefore, triangle PML is \cong to triangle BKJ (From SSS congruency)

Hence, $\angle LPM = \angle JBK$

Similarly, $\angle RPQ = \angle ABC$

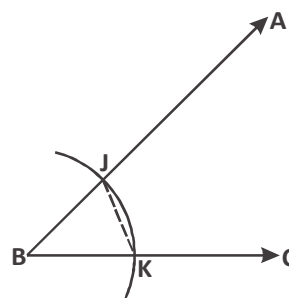

Figure - 6

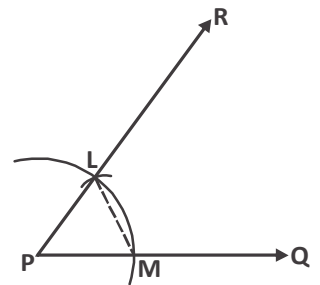

Figure - 7

Example-1. Construct a line segment which is equal to the given line segment.

Solution :

Step-1. A line segment AB is given. We have to construct a line segment which is equal to AB.

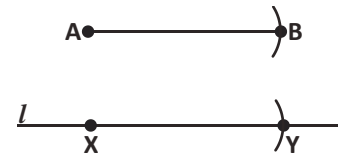

Figure - 8

Step-2. Steps of construction

1. Draw a line, say l .
2. Choose any point X on line l .
3. Now open the compass so that the radius is equal to AB. Taking X as origin draw an arc on line l and let Y be the point of intersection.

Line segment XY is congruent to line segment AB.

Step-3. Proof

Here, taking radius AB, we drew an arc from center X. Therefore $XY=AB$.

Example-2. Two angles are given. Construct an angle such that its measure is equal to the sum of the two angles.

Solution : Draw the angle $\angle LON$ which is congruent to $\angle A$ by using construction-1. Similarly, taking OL as one of the sides, draw $\angle MOL$ which is congruent to $\angle B$.

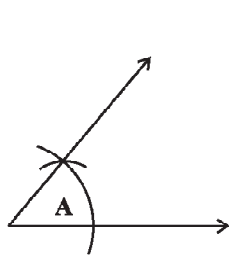

Figure - 9

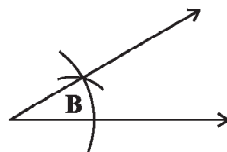

Figure - 10

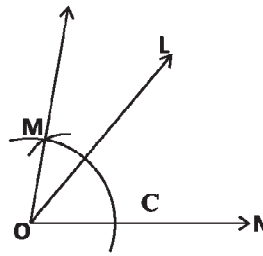

Figure - 11

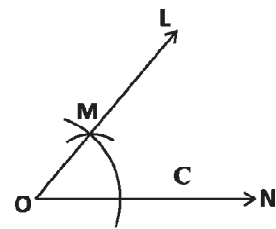

Figure - 12



Try These

1. Write detailed steps for the constructions given in example -2.
2. Draw angles measuring 30° and 90° and explain the steps.
3. Draw an isosceles triangle by taking any length for one side.
4. Draw an acute angle and construct another angle such that its value is twice the value of the previously constructed acute angle.

Construction-2 – Constructions of Parallel Lines.

Here, given a line and an external point we want to draw a parallel line passing through the point. Let us construct the parallel lines using the steps which we used in earlier constructions.

Step-1. Before the construction, think on the following questions:

1. What is the information given in the question? In which sequence should we use it? What is to be constructed? In what order?

In the given information, what is useful and what is not useful?

Here, a line and a point are given. This point is located outside the line.

We have to construct a parallel line through the point (Figure-13).



Figure - 13

2. During the construction on the basis of the given information, what are the geometrical concepts that we will have to use?

We know that if a transversal line intersects two lines and if the corresponding angles made on them are equal then both the lines are parallel.

So, from the given point we will construct a transversal line which will intersect the given line.

If at the given point we construct an angle which is equal to the angle between the transversal line and the given line, then we can say that the obtained line is parallel to the given line.

Step-2. This involves drawing a rough diagram on the basis of the given information and determining which parts are known in the expected figure. What other things are required for the construction of figure? Finally we need to construct the figure, step by step.

Steps of construction:

A line PQ and a point R are given.

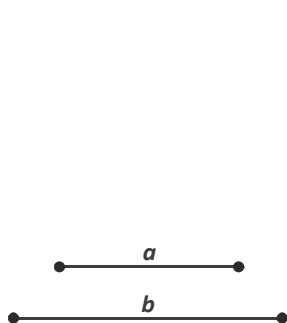

Figure - 14

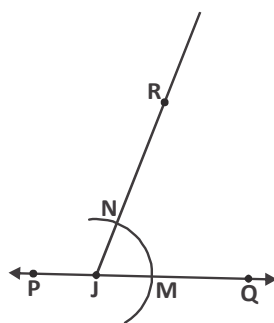

Figure - 15

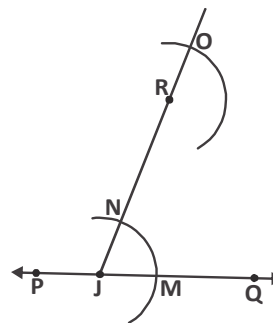

Figure - 16

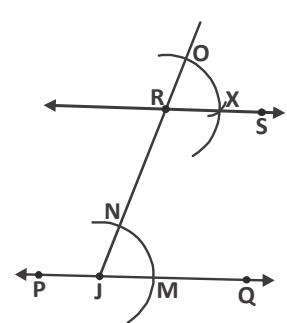

Figure - 17

We have to construct a line which passes through R and is parallel to PQ.

1. Draw a transversal line from R which intersects PQ at any point J. We know that if corresponding angles are equal then lines are parallel.
2. Now, we draw an arc of any measure from point J, which intersects PQ at M and JR at N (figure – 15).
3. Now, we will draw an arc of the same measure from the point R so that it intersects JR at Q (figure – 16).
4. Now, taking MN as length we will draw an arc from point O such that it intersects the arc which we drew earlier at point X.
5. Draw a line RS, by joining the point R to point X.

Thus, line PQ is parallel to line RS (figure-17)

Step-3. Checking the constructed figure. To see whether the constructed figure is the same as the required figure.

Proof : see the constructed figure.

Because $\angle ORX = \angle RJM$ (Corresponding Angles).

Then we can say that $RS \parallel PQ$.

Exercise -1



1. Draw two line segments 'a' and 'b' in your notebook. Construct line segments according to the given information.

(a) $a + b$ (b) $b - a$

(c) $2b + a$ (d) $3a - b$

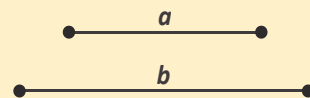

2. With the help of a protractor and a ruler draw the following angles: 15° , 45° , 105° , 75° .

3. Two angles X (obtuse angle) and Y (acute angle) are given. Draw the angles having the following measures:

(a) $X^\circ - Y^\circ$ (b) $X^\circ + Y^\circ$

(c) $(180 - X)^\circ$ (d) $2Y^\circ$

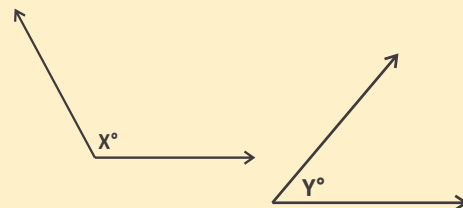

4. Three line segments of fixed measure 'r', 's' and 't' are given.

- a) Is it possible to construct a triangle using these line segments? If yes then draw the triangle.
- b) Is it possible to construct a triangle using s, t and r+t ?

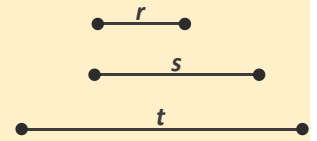

5. Draw a triangle ABC. Now from 'A' draw a line which is parallel to BC and check the sum of all the angles at vertex A as well as sum of all the angles of the triangle.

Construction – 3: Construction of a Line Segment in the Given Ratio

For this construction, we will use the Thales theorem. In the chapter on similar triangles you read about Thales theorem according to which “If in any triangle a line is drawn such that it is parallel to one of the sides of the triangle and also intersects the two remaining sides, then this parallel line will divide the two sides in the same ratio.”

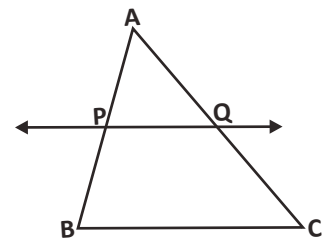

Figure - 18

If in given triangle ABC, PQ is parallel to BC, then from Thales theorem we can say that –

$$\frac{AP}{AB} = \frac{AQ}{AC} \text{ (Figure-18)}$$

If $AP = \frac{1}{3} AB$, then from the Thales theorem we can say that $AQ = \frac{1}{3} AC$.

Example-3. Find a point C on line segment AB such that $AC:AB=2:3$.

Solution :

Step-1. A line segment AB is given and on that line we have to obtain point C such that $AC:AB = 2:3$.

This means that length of line segment AC is $\frac{2}{3}$ of the line segment AB (figure-19).

Think, how will we construct? Since $AC:AB=2:3$, so



Figure - 19

If we divide the line segment AB in three equal parts and select

2 parts out of the three, then this will be $\frac{2}{3}$ of the whole line segment.

We know that a line segment which is parallel to any side of a triangle divides the remaining sides of the triangle in the same ratio (Figure-21).

So why not draw a ray which makes an acute angle with AB on which three equal parts can be taken? Now keeping in mind the ratio 2:3, join the third point with B and draw a line parallel to it from the second point.

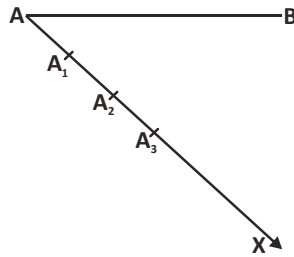

Figure - 20

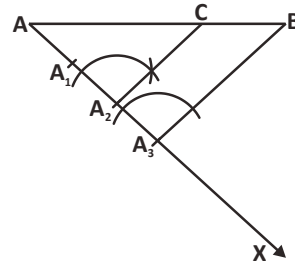

Figure - 21

Step-2. Steps of construction

1. Draw a ray AX making an acute angle at point A.
2. Cut three equal arcs on AX and name them AA₁, A₁A₂, A₂A₃.
AA₁ = A₁A₂ = A₂A₃.
3. Now, join B with A₃ and draw a parallel line from A₂ to A₃B, which intersects AB at C.

AC is the required line segment, because AC : AB = 2 : 3.

Step-3. Proof. On the basis of the geometrical construction how can we say that that

$$\frac{AC}{AB} = \frac{2}{3}$$

In $\triangle ABA_3$ or $\triangle ACA_2$, $A_2C \parallel A_3B$ (from construction)

From Thales theorem we can say that,

$$\frac{AC}{AB} = \frac{AA_2}{AA_3} \dots\dots(1)$$

From the construction we know that,

$$\frac{AA_2}{AA_3} = \frac{2}{3} \text{ (because } AA_3 \text{ is divided into 3 equal parts)}$$

$$\text{Hence, } \frac{AC}{AB} = \frac{AA_2}{AA_3} = \frac{2}{3}$$





Example-4. Draw a line segment which is $\frac{3}{2}$ of a given line segment.

Solution :

Step 1. A line segment AB is given, consider a point C on it such that

$$AC : AB = 3 : 2$$

In the previous example, point C was located between points A and B. In this example, a point C is such that $AC:AB=3:2$, therefore the point C is located outside of the line segment AB. When line AC is bigger than the line segment AB then only it will be $\frac{3}{2}$ times of AB.

Step 2: Steps of constructions

1. Draw a ray AY making an acute angle with point A and extend line segment AB upto X. (we extend AB upto X because we need to obtain a point C such that $AC:AB=3:2$).
2. Draw three equal arcs on AY and name them A_1, A_2, A_3 .
3. Now join A_2 with B and draw a parallel line from A_3 to A_2B , which cuts AX at C.

The required point C lies on AX such that $\frac{AC}{AB} = \frac{3}{2}$

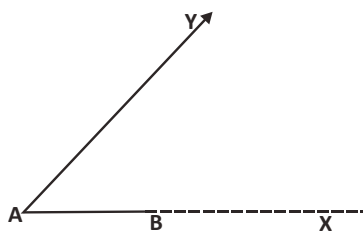

Figure - 22

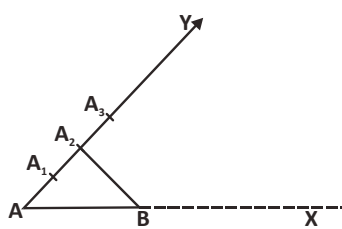

Figure - 23

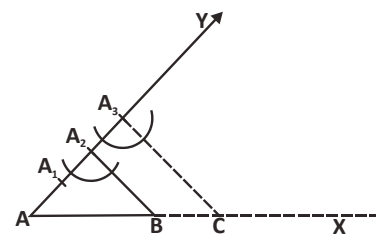

Figure - 24

Step-3. Proof. On the basis of the geometrical construction, can we say that $\frac{AC}{AB} = \frac{3}{2}$?

In $\triangle ACA_3$ and $\triangle ABA_2$

$A_2B \parallel A_3C$ (from construction)

$$\therefore \frac{AC}{AB} = \frac{AA_3}{AA_2} \dots\dots(1) \text{ (from Thales theorem)}$$

From the construction, we know that

$$\frac{AA_3}{AA_2} = \frac{3}{2}$$

$$\text{Thus, from equation (1) } \frac{AC}{AB} = \frac{3}{2}$$

In this construction, we obtained line segment AC which is bigger than the given line segment by a fixed ratio. $AC = \frac{3}{2}AB$ or we can say that point C divides the line segment AB in the ratio 3:2.

Construction of the Similar Triangles

We know that in similar polygons corresponding angles are equal and corresponding sides are in the same ratio.

These two properties of similarity are also applicable for the similar triangles.

Construction – 4: Construct a triangle which is similar to given triangle ABC and whose sides are $\frac{3}{5}$ of the corresponding sides in triangle ABC.

Step – 1. We have to construct triangle which is similar to given triangle ABC. We know that in similar triangles, corresponding angles are equal and the corresponding sides are in the same ratio. This ratio $\frac{3}{5}$ is given. By using the previous construction, let us construct similar triangles.

Step - 2. Steps of construction

1. Draw a ray BX from B making an acute angle on the other side of A.
2. Cut 5 equal arcs on BX and name them B_1, B_2, B_3, B_4, B_5 respectively.

From this we obtain $BB_1 = B_1B_2 = B_2B_3 = B_3B_4 = B_4B_5$.

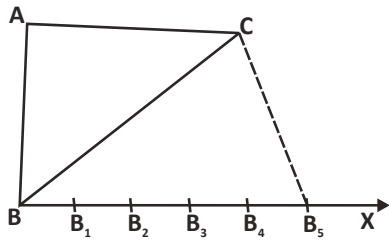

Figure - 25

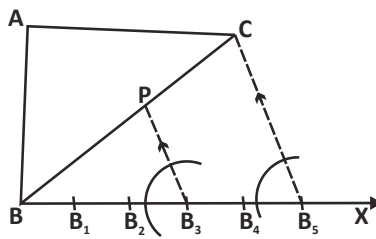

Figure - 26

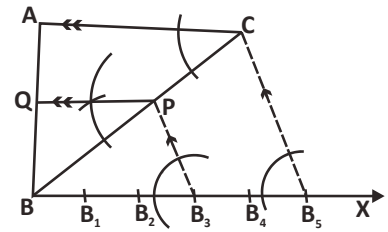

Figure - 27

3. Now join B_5 with C and draw a line parallel to B_5C from B_3 which intersects BC at P .
4. Now, draw a parallel line from P to AC , which intersects AB at Q .

QBP is the required triangle.

Step-3. Proof

How can we check that $\triangle QBP$ and $\triangle ABC$ are similar triangles?

One of the ways in which we can do this is that we can measure the sides of both the triangles and see whether the corresponding sides are in the same ratio or not.

Another way of proving can be using the (Angle- Angle-Angle similarity)

In $\triangle QBP$ and $\triangle ABC$

$$\angle QBP = \angle ABC \text{ (common angle)}$$

$$\angle PQB = \angle CAB \text{ (corresponding angles) (from the construction } PQ \parallel CA)$$

$$\angle BPQ = \angle BCA \text{ (corresponding angles) (from the construction } PQ \parallel CA)$$

Hence, $\triangle QBP \sim \triangle ABC$ (Angle-Angle-Angle similarity)

$$\text{That is } \frac{QB}{AB} = \frac{BP}{BC} = \frac{QP}{AC}$$

$$\frac{BP}{BC} = \frac{3}{5} \quad \text{(from the construction } BC \text{ is equal to 5 parts and } BP \text{ to 3 parts)}$$

$$BP = \frac{3}{5} BC$$

$$\therefore QP = \frac{3}{5} AC \text{ and } QB = \frac{3}{5} AB$$



Example-5. Construct a triangle which is similar to the given triangle ABC and whose sides are $\frac{5}{3}$ times of the corresponding sides of triangle ABC.

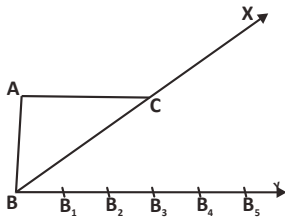

Figure - 28

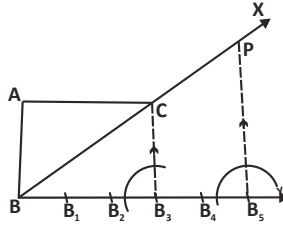

Figure - 29

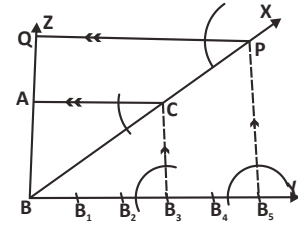

Figure - 30

Step-1. A triangle ABC is given to us. We have to construct a triangle which is similar to the given triangle and whose sides are $\frac{5}{3}$ of the corresponding sides of the given triangle.

Step-2. Steps of construction

1. Draw a ray BY from point B making an acute angle on the other side of point A. Extend BC and BA to get rays BX and BZ respectively.
2. Now take 5 equal parts on BY and name them $BB_1, B_1B_2, B_2B_3, B_3B_4, B_4B_5$.
3. Now join B_3 to C. From B_5 draw a line parallel to B_3C which intersects BX at P.
4. Now draw a line parallel to AC from P which intersects BZ at Q. QBP is the required triangle.

Construction of the similar quadrilaterals

Let us construct the similar quadrilateral in the same way that we constructed similar triangles.

Quadrilateral ABCD is given to us. We have to construct a quadrilateral similar to ABCD such that each of its side is $\frac{2}{5}$ of the corresponding sides of quadrilateral ABCD.

Step-1. Quadrilateral ABCD is given to us. We have to construct a quadrilateral similar to ABCD such that each of its side is $\frac{2}{5}$ of the corresponding sides of quadrilateral ABCD. Here, construction is done in the same manner as in similar triangles. A point we need to remember is that first we have to construct the diagonal of given figure.

Step-2. Stages of construction

1. Construct a ray BX from point B making an acute angle CBX.
2. Now take 5 equal parts on BX and name them $BB_1, B_1B_2, B_2B_3, B_3B_4, B_4B_5$.
3. Join B_5 to D and from B_2 draw a line parallel to which intersects BD at R.
4. Now, from R draw a line parallel to AD which intersects AB at P.
5. Similarly, draw a line parallel to CD from R which intersects BC at Q.

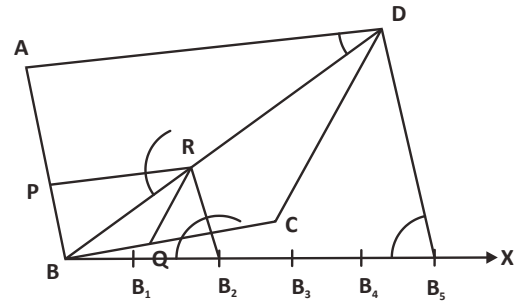

Figure - 31

Thus, we obtain the required quadrilateral PBQR.

Drawing Perpendiculars

Example-6. Draw a perpendicular at point C on line k.

Solution:

Step-1. We have to draw a perpendicular at point C on line k.



Figure - 32

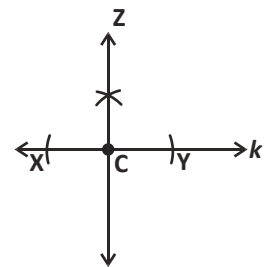

Figure - 33

Step-2. Steps of Constructions

1. Take point C as origin on k and on both of its sides cut arcs on k taking any radius. Name the points of intersection as X and Y.
2. Take a radius of more than CX and by taking X and Y as origins, draw arcs on one side of the line. The arcs cut each other at a certain point.
3. Draw a line CZ by joining C to this intersection point. CZ is perpendicular to line k and passes through the point C.

Example-7. Point C is outside line k. Construct a perpendicular at line k which passes through point C.

Solution : (Hint) First consider the point C as origin and then mark points X and Y on k such that both points are at an equal distance from C. Then by taking the points X and Y as origins obtain the point Z.

Write the detailed steps of this construction on your own.

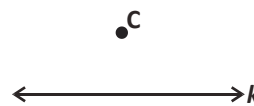

Figure - 34

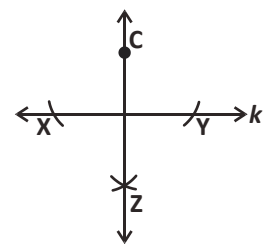

Figure - 35

Try these



1. Draw a line segment AB of length 5.8 cm and take a point C on it such that $AC:CB = 3:4$. Check whether $AC:CB$ is 3:4 or not.
2. Construct a line segment which is $\frac{7}{5}$ of any other line segment.
3. Draw a triangle PQR in which $QR = 6$ cm, $PQ = 5$ cm and $\angle PQR = 60^\circ$. Draw a triangle ABC similar to triangle PQR, in which $AB = \frac{2}{5} PQ$.
4. Construct a triangle ABC in which $BC = 5.5$ cm, $\angle ABC = 75^\circ$ and $\angle ACB = 45^\circ$. Draw a triangle XYZ similar to triangle ABC in which $YZ = \frac{5}{4} BC$.

Exercise - 2



1. Construct a similar triangle which is $\frac{3}{5}$ of the given triangle.
2. Construct an isosceles triangle PQR. Also construct a triangle ABC in which $PQ = \frac{3}{4} AB$.
3. Construct a triangle PQR. Also construct a triangle ABC in which $AB = \frac{2}{3}$ of PQ.
4. Construct two similar triangles. First triangle should be $\frac{4}{3}$ times the other triangle.

Till now you studied about construction of the similar triangles. Now, we will do some more constructions by using the properties which we studied in previous classes.

Perpendicular bisector

Perpendicular bisector is the line which divides a given line segment into two equal parts while making a right angle with it.

Construction of Perpendicular Bisector

1. Draw a line segment AB.

2. Extend both the sides of the compass such that its length is more than half of the given line segment.
3. Draw an arc on both the sides of the line segment by putting the tip of the compass at point A. Again repeat the same process by putting the compass at point B.
4. Join the intersection points of the arcs with the help of a scale.

This line “l” is the perpendicular bisector of line segment AB.

Is each point on the perpendicular bisector at an equal distance from point A and point B?

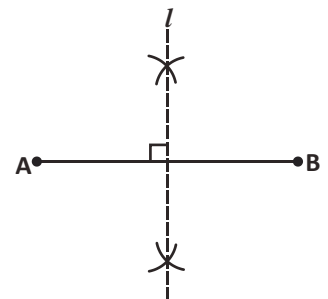

Figure - 36

Let us see

Take a point O on the perpendicular bisector. Join this point to both the end points “A” and “B” of the line segment. Now, in triangle AOD or in triangle BOD,

$$AD = DB \text{ (D is the midpoint of AB)}$$

$$\angle ODA = \angle ODB \text{ (Right angle)}$$

$$OD = OD \text{ (Common)}$$

$$\therefore \triangle AOD \cong \triangle BOD \text{ (SAS congruency)}$$

Hence, $OA = OB$

Each point of the perpendicular bisector is at an equal distance from point A and point B.

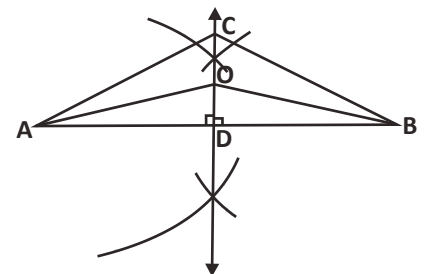

Figure - 37

Some more Constructions of triangles

Step-1. A triangle is given to us. Now we have to construct a circle such that it passes through all three vertices A, B and C of the triangle.

Think about how to do this construction:

Because the required circle will pass through all the vertices of the triangle therefore we can say that the centre of the circle is at equal distance from all the vertices. We also know that any point on the perpendicular bisector is at equal distance from the end points of the sides. All the points on the perpendicular bisector of the side AB of triangle ABC will be at equal distance from vertex A and vertex B. Similarly all the point on the perpendicular bisector of side BC will be at equal distance from vertex B and vertex C.

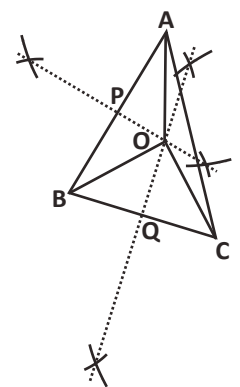

Figure - 38

Suppose that both the perpendicular bisectors intersect each other at a certain point and we name this point as “O”. Because Point O is located on both the perpendicular bisectors hence $OA = OB = OC$. Now draw a circle by considering “O” as the center and OA as a radius. Is the circle which we have drawn passing through all the vertices?

Let us see -

Step-2. Steps of construction

1. Draw a triangle ABC.
2. Draw a perpendicular bisector on side AB and AC which intersects AB at P and BC at Q. The perpendicular bisectors intersect each other at "O".
3. Now draw a circle by taking O as center and with OA as radius. You can see that this circle is passing through all three vertices.

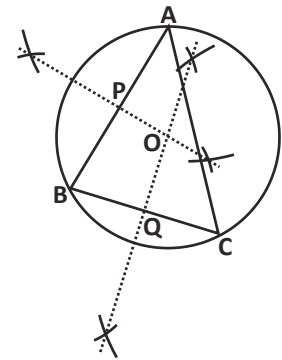

Figure - 39 (i)

Step-3. Proof

How do we check that the circle is passing through all three vertices A, B and C of the triangle?

In $\triangle AOP$ and $\triangle BOP$ (figure-39(ii))

$$AP = PB \quad (\text{Why?})$$

$$\angle OPA = \angle OPB \quad (\text{Why?})$$

$$OP = OP \quad (\text{Common})$$

Hence, $\triangle AOP \cong \triangle BOP$

From this we can say that,

$$OA = OB \dots (i)$$

Similarly, $\triangle BOQ \cong \triangle COQ$

$$\text{Therefore } OB = OC \dots (ii)$$

From (i) and (ii), we can say that

$$OA = OB = OC$$

This means that points A, B and C are at an equal distance from centre O. So the circle drawn by taking OA as radius will pass through B and C as well.

The point at which the perpendicular bisectors of the sides of any triangle meet is called the circumcenter of the triangle. Here point O is the circumcenter of triangle ABC and the circle which passes through ABC is called the circumcircle.

Angle Bisector

Divide the given angle into two equal parts.

Solution :

Step-1. A triangle ABC is given. We have to construct a ray which divides $\angle ABC$ into two equal parts.

Figure - 39 (ii)

Think about how we can do this. We know that the angle bisector is a line which divides any angle into two equal parts, hence both the resulting angle are equal. If we construct two triangles in such a manner that angle bisector is a common side in both the triangles and the triangles are congruent (here $BE=BF$ and $DE=DF$), then by the SSS congruency both the obtained triangles are congruent. For obtaining congruent triangles we require a point which is at an equal distance from the points on the sides BA and BC.

Step-2. Steps of constructions

1. By taking vertex B as centre, draw an arc of any radius which intersects BA and BC at points E and F respectively.

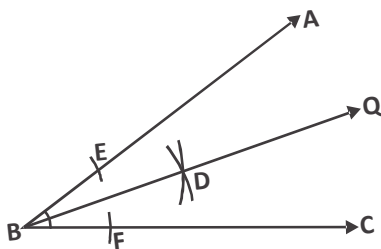

Figure - 40

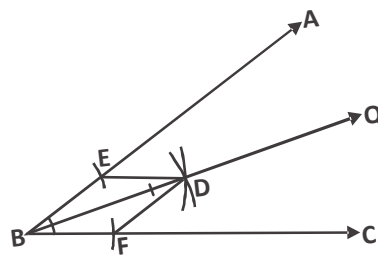

Figure - 41

2. Take E and F as center and radius slightly more than $\frac{1}{2}$ of EF, draw arcs which intersects each other at D.
3. Now draw ray BD; this is the required angle bisector.

Step-3: Proof: How can we say that BD is the angle bisector of given angle. Let's see.

Join D to E and F, now in triangles BED and BFD,

$BE=BF$ (radii of the same arc)

$ED=FD$ (radius of the same arc)

$BD=BD$ (common side)

Hence, $\triangle BED \cong \triangle BFD$ (from SSS)

From this we can say that $\angle ABD = \angle DBC$ (CPCT)



Distance of Angle Bisector from Sides

Take a point P on the angle bisector. To calculate the distance of point P from sides BA and BC, draw perpendiculars from point P on BA and BC.

Draw a perpendicular from point P on side AB which intersects AB at M. Similarly draw a perpendicular from point P on side BC which intersects at R. Now in triangle BMP and in triangle BRP,

$\angle BMP = \angle BRP$ (Right Angle)

$\angle MBP = \angle RBP$ (Because BP is Angle Bisector)

$BP = BP$ (Common)

Hence, $\triangle BMP \cong \triangle BRP$ (AAS congruency)

From this we can say that $PM = PR$ (CPCT)

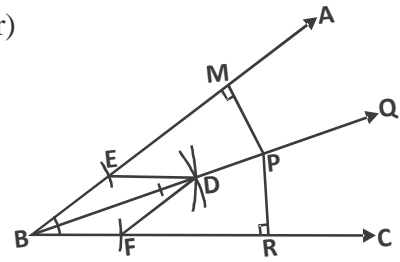

Figure - 42

Incircle

Step-1. A triangle ABC is given to us and we have to construct a circle which touches all the sides of the triangle.

How to construct

Because the circle touches all the sides of the triangle, therefore the centre of the circle is at equal distance from all the sides. We know that any point at the angle bisector is at an equal distance from the arms of the angle. There are many such points on the angle bisector of the angle ABC which are at an equal distance from BA and BC. Similarly, there are many such points on the angle bisector of angle BCA which are at an equal distance from CB and CA. If we take the point O as the point at which both the angle bisectors intersect each other then O is at an equal distance from AB, BC and CA. Take O as centre and with radius equal to the perpendicular distance between center and any side, draw a circle. Does the circle touch all the sides of triangle ABC?

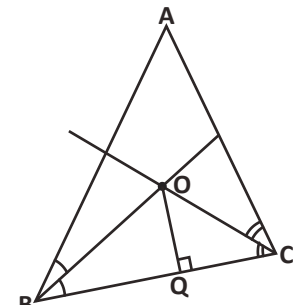

Figure - 43

Step 2. Steps of Construction

1. Construct a triangle ABC.
2. Draw angle bisectors of angle ABC and angle BCA. The point at which both cut each other is taken as the centre O.
3. Now draw a perpendicular from the point O to side BC which intersects BC at Q. Draw a circle taking O as centre and OQ as radius. In the figure you can see that this circle touches all the three sides. Hence, the perpendicular distances AB, AC and CA from O are same.

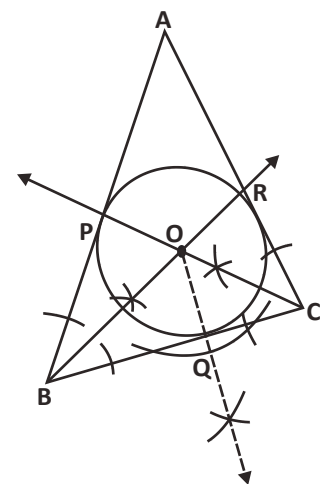

Figure - 44

Step-3. Proof

Let's see on the base of the mathematical arguments whether the obtained circle touches all the three sides?

In triangle POB and in triangle BOQ,

$$\angle PBO = \angle QBO$$

$$\angle OPB = \angle OQB = 90^\circ$$

$$OB = OB \text{ (Common)}$$

Hence, $\Delta POB \cong \Delta QOB$

Therefore, $OP = OQ \dots (i)$

Similarly, $\Delta ROC \cong \Delta QOC$

Therefore, $OR = OQ \dots (ii)$

From (i) and (ii), we can say that

$$OP = OQ = OR$$

Now, taking O as origin and OP as radius make a circle touching all the three sides of the triangle.

The point at which the angle bisectors of any triangle meet each other is called incentre of the circle and that circle is called incircle.



Try these

1. Construct incircle and circumcircle for triangle ABC when:
 - (i) $AB=3\text{cm}$, $BC=4\text{cm}$ and $\angle B=90^\circ$. Also find the radius of the incircle and circumcircle.
 - (ii) $AB=BC=CA=6\text{cm}$, where will the incentre and circumcentre be located?
 - (iii) $BC=7\text{ cm}$, $\angle B=45^\circ$, $\angle A=105^\circ$, where will the incentre and circumcentre be located?



Exercise-3

1. Construct according to the given information (use a compass)

i) Draw a perpendicular at point p on line l .

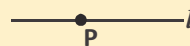

ii) Draw a perpendicular from point S on line l .



iii) Draw the perpendicular bisector of line segment JK.



iv) Draw a line which is parallel to line l and passes through point T.

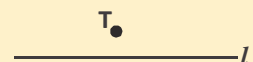

v) Draw a line which is parallel to ED and passes through point F.

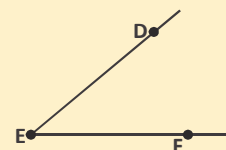

vi) draw a perpendicular from point G on HJ.

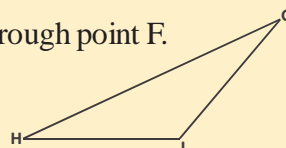

This can be done using measurements or proofs to check whether the constructed figure is as per requirements or not.

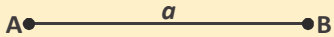
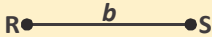
2. Two line segments $AB=a$ and $RS=b$ are given. Now, construct according to the given information.
 - (i) Draw a rectangle of sides 'a' and 'b'. 
 - (ii) Draw a square of Perimeter $4b$. 
 - (iii) Draw a square where diagonal is equal to a.
 - (iv) Draw a cyclic quadrilateral having sides a and b and included angle is θ .
3. Construct a circumcircle on a right angle triangle. Find the value of the radius of the constructed circle.
4. Construct a incircle on a right angle triangle . find the value of the radius of the constructed circle.
5. Construct incircle and circumcircle on equilateral triangle, now calculate the incircle and circumcircle. Are both of them located at the same point?
6. Take three non collinear points and construct a circle which pass through them.
7. Mohan want to hoist a flag at the centre of the circular ground of the School. He has to take help from Rahul and Zoya to find the place on the field where the pole should be fixed. Think, now they all together found the place?



What We Have Learnt

1. Understanding a given question - Before we start working on a question, the first step is to read the question and to see what information is given and what is to be constructed. In some manner it is like to convert it into mathematical form and context. Here we have to understand which one of the given information is useful and which one is not. Which geometrical concept can be used on the basis of the given information, this kind of thinking is helpful in understanding the question.
2. On the basis of given information we can draw a rough diagram and by analyzing it we can think about ways to solve the problem. On the basis of the desired shape is known and calculating what more things are required to about the ways how to solve it. In this we have to think that which part of the desired shape is known now and what more should be required to construct the figure.
3. After analyzing and drawing the rough diagram, geometrical construction is possible in a stepwise manner.
4. At the end after the construction see whether the constructed figure meets the requirements of the question.

PROOF OF MATHEMATICAL STATEMENTS

CHAPTER

14

Introduction

In our daily lives we often try to logically judge statements and claims instead of just accepting them. For example, you must have heard or seen advertisements like "you can write faster if you use this pencil; your child will run faster if you give this tonic to her". They say that if you want to write faster then you should use that pencil and you will run faster by taking the tonic otherwise you will be left behind. Now the point is that how do we check these claims and statements? In other words, how can we check their validity?

One method is empirical observation to find out how many children came first in race after taking the tonic or height of how many children increased or writing speed of how many children increased by using that pencil. We can analyse further on the basis of the above observations. But will this method work in all situations? Can it be applied on mathematical statements?

For example, read the following statements:-

1. Multiple of a number is a multiple of all the factors of that number.
2. If a number is divisible by 8 it is also divisible by 4.
3. 0.000001 is bigger than 10^{-20} .
4. The sum of two odd numbers is always an even number.
5. The product of two numbers is bigger than the numbers.

Can we use the above described method to check such statements i.e. Is it possible to find all the multiplies and factors of every number to check statement (1) Can we will divide by 4 all the numbers till infinity that are divisible by 8 to check statement (2)?

It is clear that such statements cannot be checked by empirical method. Some general method is required so that we can find that 0.00001 is bigger or smaller than 10^{-20} . Similarly, we need a rule on the basis of which the sum of two odd numbers can be shown as an even number or product of numbers can be checked.

Let us find a method to check these mathematical statement.

Proving Mathematical Statements

Let us take some examples of mathematical statements.

Statements about Numbers

Statement-1 : The sum of an odd number and an even number is always an odd number.

Proof : We can write any even number b as $b = 2k$, where k is an integer.

(By definition of even integers, since b is divisible by 2) (1)

Any odd number a can be written in the form of $a = 2k_1 + 1$, where k_1 is an integer.

(Adding 1 to an even number given us an odd number) (2)

Now by adding (1) and (2)

$$a + b = 2k_1 + 1 + 2k = 2(k + k_1) + 1$$

$$= 2m + 1 \text{ where } m = k + k_1 \text{ and } m \text{ is a integer (Why?)}$$

Since $2m$ is an even number.

So $2m + 1$ is a odd number.

So, the sum of an even number and an odd number will always be an odd number.

You can see that here we proved the statement on the basis of definitions of even integers and odd integers.

Geometric Statements

You have learnt to prove geometric statements in class-IX. For example, statements such as "The sum of interior angles of a quadrilateral is 360° " or "If a transversal intersects two parallel lines then each pair of alternate interior angles are equal."

Now, we will prove another statement and try to find out key aspects of its proof.

Statement-2 : If two parallel lines are cut by a transversal, each pair of corresponding angles are equal.

Proof : Let a transversal **PQ** intersect two parallel lines **AB** and **CD**.

Here $\angle MND$ and $\angle AMN$ are a pair of alternate interior angles.

And, $\angle MNC$ and $\angle BMN$ are another pair of alternate interior angles.

We have to see if $\angle MND = \angle AMN$ and

$$\angle MNC = \angle BMN$$

Since $\angle PMB$ and $\angle MND$ are corresponding angles

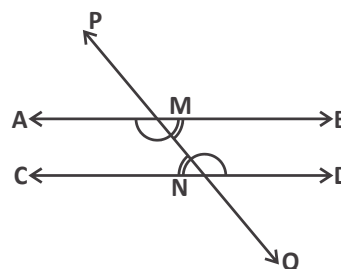

$$\therefore \angle PMB = \angle MND \quad (\text{By corresponding angles axiom}) \quad \dots(1)$$

And $\angle PMB = \angle AMN \quad (\text{By vertically opposite angle theorem}) \quad \dots(2)$

By (1) and (2)

$$\angle MND = \angle AMN \quad \dots(3)$$

Similarly,

$$\angle MNC = \angle BMN \quad \dots(4)$$

So, here both the pair of alternate interior angles are equal.

Key Aspects of the Proof

Read both proofs given above carefully and list out the key aspects which are used to prove these statements.

Madhavi says that she find three key aspects of proof:-

1. We have made use of previously drawn results such as theorems, definitions or axioms to prove both the statements.
2. Each statements of proof is logically joined with previous statement.
3. Special type of symbols and signs are used to write the statements and long statements are written in brief by the use of these symbols and signs.

Do you agree with Madhavi?

Try These

1. "The sum of interior angles of a quadrilateral is 360° ."
Prove this statement and find out all three key aspects of the proof.

Think and Discuss

Read the proof of the two statements given above, which we have proved, and discuss the following questions in the class:-

1. Which definitions, theorems and axioms were used?
2. List out those signs, symbols which are used while proving the statements.

Understanding Proofs

Let us try to understand how the all three key aspects given above help to read, understand and write proofs.

1. **Use of "Definitions, previously drawn theorems and axioms".**

If a statement is given to you to prove, how will you start?

Obviously for this you need all those known information on the basis of which the statement can be proved. This information can be postulates, definitions and proved statements. Therefore, to prove a statement first you need to think which information you have, so that you can use the information in appropriate situations.

In the chapter on similarity we used AA criteria to prove SAS and SSS theorem of congruency in two triangles. Similarly to prove that $\sqrt{2}$ is an irrational number, we used definition of rational numbers and to prove that adjacent sides of a parallelogram are equal we used the theorem "pair of alternate angles".

Try These

Find out the definitions which we used to prove the statements given above.

2. Deductive Reasoning

It is important to think while proving a statement that what is the basis of writing one statement after a previous statement. To prove mathematical statements, we need information of previously known definitions and postulates and proved theorems.

1. Write the deductive statement of the following statements:-

" l and m are parallel lines"

We know that there is no common point in parallel lines by the definition of parallel lines (Reasoning).

Therefore, we can say that if l and m are any two parallel lines then there will not be any common point on them. (Deductive statement)

Let us consider another example.

2. If $a + 5 = b$ and $c = b$

then $a + 5 = c$. so, $a = c - 5$

3. In both the examples given above on the basis of definitions and postulates a statement is deduced from the previous statement. Similarly we deduce a statement from the previous statement on basis of proved statements and theorems.

Let us take an example:-

In $\triangle AOB$ and $\triangle POQ$, $\angle AOB = \angle POQ$,

$OA = OP$ and $OB = OQ$

On the basis of SAS congruency theorem we can say that

$\triangle AOB \cong \triangle POQ$

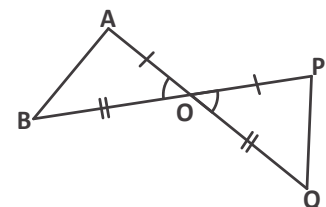

4. Deductive reasoning helps in reaching from general truth statements to specific truth statements. For example, if we prove that product of two odd numbers is an odd number once then if we know the given numbers are odd, then we can say that the product of two odd numbers is an odd number without multiplying them.

7428391 \times 607349 will an odd number because 7428391 and 607349 are odd numbers.

Try These

1. Prove that - the sum of any two successive odd numbers is a multiple of 4.
2. Write the deduced statement on the basis of given statements:-
Statement-a : Square is a rectangle
Statement-b : Rectangle is a parallelogram.
Statement-c : Chord AB makes $\angle APB$ on perimeter of circle.
3. If ABCE and PQRS are two rectangles then what we can deduce about their angles, sides and diagonals? What we can say about their congruency and similarity.

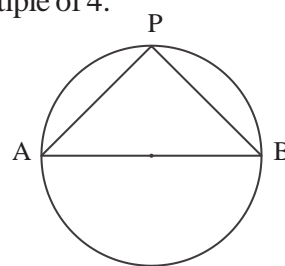

Can we prove mathematical statements by measuring and cutting

While learning mathematics, we often accept some facts at a general level by measuring or considering some specific examples. The sum of the interior angles of a triangle is 180° . To show this we either measure the angles or cut the corner of triangle and put them together to show that sum of interior angles is 180° . But it is not the proof of this statement. By showing it we can't generalise this statement for all the triangles.

We know that the sum of interior angles of a triangle is 180° . This is a theorem which is a generalised statement applicable on all triangles. Suppose you measure the angles of a triangle and the sum of angles is 180° even then we cannot say this is true some any other triangle. We cannot repeat the same process for all triangles. Further, if sum of the angles is more or less than 180° then we say that it is not measured properly. We say this because we know that the sum of angles of a triangle on a plane surface is 180° and this can be generalised also so that it is true for all triangles.

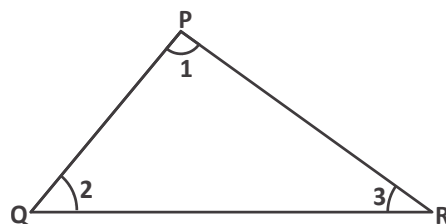

In mathematics, to prove a statement deductive reasoning is used so that any statement can be checked and established true in a generalised form. For example imagine a triangle, shape and measurement of whose angles is unknown. The conclusion for this triangle will be applicable for all triangles.

Theorem-1 : The sum of interior angles of a triangle is 180°

Proof : A triangle PQR is given whose angle are $\angle 1$, $\angle 2$ and $\angle 3$.

To Prove : $\angle 1 + \angle 2 + \angle 3 = 180^\circ$

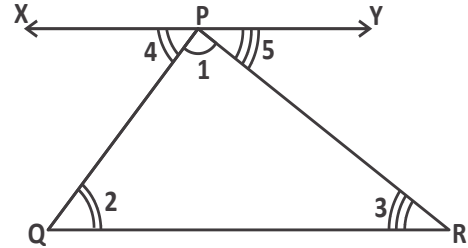

Construction : Draw a line XPY parallel to QR and passing through point P so that we can use the property of parallel lines.

In figure,

$$\angle 4 + \angle 1 + \angle 5 = 180^\circ \text{ (XPY is a line)} \quad \dots(1)$$

$$\angle 4 = \angle 2 \text{ and } \angle 5 = \angle 3 \text{ (Pair of alternate angles)} \quad \dots(2)$$

On putting the value of $\angle 4$ and $\angle 5$ in (1)

$$\angle 2 + \angle 1 + \angle 3 = 180^\circ \quad \dots(3)$$

$$\text{So } \angle 1 + \angle 2 + \angle 3 = 180^\circ \quad \dots(4)$$

We can say this is true for any triangle, for different values of $\angle 1$ and $\angle 2$ and different length of PQ and QR, etc.

Try These

Prove that

1. The exterior angle of a triangle is equal to the sum of two interior opposite angles.
2. If two angles of a triangle are equal then its two opposite sides are also equal.
3. The diagonal of a parallelogram divides it into two congruent triangles.
4. If in two right triangles, the hypotenuse and one side of the first triangle are equal to the hypotenuse and one side of the other triangle, then the two triangles are congruent.

3. Writing exact, brief and clear mathematical statements by using mathematical language.

Read this property of natural number

$$n_1 + n_2 = n_2 + n_1 \quad \forall n_1, n_2 \in \mathbb{N} \quad (1)$$

Can you tell which property of natural numbers is described?

This statement tells about the commutative property of sum of natural numbers. In other words we can say that even if we change the order of two natural numbers, their sum will remain the same. The same is written in brief with the help of letters, symbols or signs in the above statement. The two natural numbers are denoted as n_1 and n_2 . And there are two new symbols \forall and \in .

This small statement tells us that the sum of two natural numbers does not depend on what is added to what. It means that we can replace the value of n_1 and n_2 by any value of natural numbers and we get $n_1 + n_2 = n_2 + n_1$, for every value of natural number.

Similarly we can also write law of commutative property for multiplication.

Now read the definition of rational numbers which is written with the help of letters and symbols.

$$Q = \frac{p}{q} \quad \text{Where } p, q \in \mathbb{I} \text{ \& } q \neq 0$$

In words, "can write any rational number in the form of $\frac{p}{q}$ where p, q are integers and the value of q is not 0.

Try These

Write in words the following mathematical statements:-

- (i) $a^m \times a^n = a^{m+n}$ $a, m, n \in \mathbb{N}$
- (ii) $p(x + y) = px + py$ $\forall p, x, y \in \mathbb{R}$
- (ii) Write all properties of natural numbers in symbols.

Symbols and Mathematical Statements in Mathematics

Definitions, properties and rules are written in brief by the use of mathematical language. If we will not use mathematical signs, symbols while proving and writing mathematical statements will have to write more and more. Mathematical language use signs to write a statements in accurate form. So using mathematical language is both necessary and helpful while proving theorems.

Generally many signs are used in mathematics, here are some signs and their meanings.

S.No.	Sign	Meaning
1.	=	Is equal to
2.	<	Less than
3.	>	Greater than
4.	\therefore	Therefore
5.	\because	Since
6.	\neq	Is not equal to
7.	\forall	For all
8.	\in	Belongs to
9.	\notin	does not belong to
10.	\sim	Is similar to
11.	\cong	Is congruent to
12.	\Rightarrow	Implies
13.	\parallel	Is parallel to

Example-1. Write the following literal (word) statements as mathematical statements:-

- (A) Commutative property is not satisfied while doing subtraction of integers.
 (B) The square of an integer is greater than or equal to that number.

Solution : (A) $a - b \neq b - a \quad \forall a, b \in \mathbb{I}$

To write this mathematical statement we use two variables a and b and the signs \neq , \forall , \in .

(B) $x^2 \geq x \quad \forall x \in \mathbb{N}$

Here x denotes a natural number.

Try These

Write mathematical statements for the following:-

- (i) On multiplying an integer by 1 we will get the same integer.
- (ii) The sum of two sides of a triangle is greater than the third side.
- (iii) The sum of two fractional numbers is also a fractional number.

Exercise-1

1. State whether the following mathematical statements are true or false. Justify your answers:-

1. The sum of interior angles of a quadrilateral is 350° .
2. $x^2 \geq 0$ for a real number x .
3. The sum of two even numbers is always an even number.
4. All prime numbers are odd.
5. $3n + 1 > 4$, where n is a natural number.
6. $x^2 > 0$, where x is a real number.
7. $(a + b) + c = a + (b + c) \quad \forall a, b, c \in \mathbb{N}$
8. $(p - q) + r = p - (q + r) \quad \forall p, q, r \in \mathbb{Q}$
9. $(x + y) - z = x + (y - z) \quad \forall x, y, z \in \mathbb{R}$

2. Some axiom, theorem and definitions are given in the following table. Read carefully-

- | | |
|----|---|
| 1. | Whole is greater than part (Axiom) |
| 2. | If all three sides of a triangle are different in measure, then that triangle is called a scalene triangle. (Definition) |
| 3. | If n is an odd integer then it can be expressed as, $n = 2k + 1$, where k is any integer (Definition). |
| 4. | Two triangles are congruent if the three sides of one triangle are equal to the corresponding three sides of the other triangle (Theorem) |
| 5. | If two things are equal to the same third thing then they also equal one another. (Axiom) |

Write possible conclusions on the basis of the above statements for the following statement.

- (i) In triangle RST and XYZ, $RS = XY$, $ST = YZ$ and $TR = ZX$.

(We can deduce this conclusion on the basis of statement –4 that $\Delta RST \cong \Delta XYZ$)

(ii) $\frac{AB}{2} = AC$

(iii) $l = \frac{k+5}{2}$ and $2m = k + 5$, where k, l and $m \in \mathbb{R}$

(iv) In ΔDEF , $DE \neq EF \neq FD$

(v) 141 is an odd integer.

3. If n_1 and n_2 are two even integers and k_1 and k_2 are any two integers then,

(i) Write n_1 and n_2 in the form of k_1 and k_2 respectively by using definition of even integers.

(ii) Write the product $n_1 n_2$ in the form of k_1 and k_2 .

(iii) Write $n_1 + n_2$ in the form of k_1 and k_2 .

(iv) Is $n_1 \times n_2$ even number or odd number? Why?

(v) Is $n_1 + n_2$ even number or odd number? Why?

4. If $ax^2 + bx + c = 0$ is a quadratic equation where $a, b, c \in \mathbb{R}$ and $a \neq 0$ then which of the following equations is a quadratic equation. Give reasons.

(i) $ax^2 - bx + c = 0$ (ii) $bx + c = 0$ (iii) $ax^2 + c = 0$

(iv) $ax^2 = 0$ (v) $bx = 0$

5. Definition of rational number (Q) is given below:-

$$Q = \frac{p}{q} \text{ where } \forall p, q \in \mathbb{I} \text{ and } q \neq 0$$

(i) Write the definition of rational number in words.

(ii) Is $\frac{6}{0}$ a rational number?

(iii) Is $\frac{81}{1}$ a rational number? Give reason on the basis of given definition.

(iv) If $\frac{b+9}{a-5}$ is a rational number, where $a, b \in \mathbb{N}$ (Natural numbers), then which value of a is not valid here? Why?

(v) If $\frac{p^2+7}{q^2-25}$ is a rational expression then here, 5 and -5 cannot be values of q (Use definition).

Methods of Proving Mathematical Statements

So, generally we prove mathematical statements by deductive reasoning. Let us consider some more examples:-

"If $\triangle ABC$ is an equilateral triangle then it is also an isosceles triangle."

If a triangle is equilateral then its three sides are equal. It means that if all its sides are equal then its any two sides will also be equal. So, it would also be isosceles.

Let us now try to express these facts into symbolical form.

A : $\triangle ABC$ is a triangle.

B : $\triangle ABC$ is an isosceles triangle.

Now, if statement A is right then statement B is also right.

So, we expressed it in the following way.

$A \Rightarrow B$ (we read it as "if A then B" or 'A implies B').

Here \Rightarrow this symbol stands for implies.

Try These

1. Write some more statements of this type which we can prove by deductive reasoning.
2. Does $A \Rightarrow B$ also show that $B \Rightarrow A$? Give reason.

Use of Implies

Let us consider some examples.

Statement-1 : If $x^2 = 4$ then $x = 2, -2$

A : $x^2 = 4$

B : $x = \pm 2$

We know that if $x^2 = 4$, then values of x will be 2 and -2 . So $A \Rightarrow B$

Statement-2 : If m is a multiple of 9 then m is also a multiple of 3.

A : m is a multiple of 9

B : m is a multiple of 3

We know that if a number is multiple of 9 then it will be also multiple of 3. So $A \Rightarrow B$.

Try These

Find out appropriate logical relation in the following statements and use sign (\Rightarrow) to express them.

1. P : Quadrilateral ABCD is a rectangle.
Q : Quadrilateral ABCD is a square.
2. A : Point P_1 , lies on line l and m .
B : Lines l and m are not parallel.

Proving Some More Statements

Now we prove and test those statements which we can't prove directly by deductive reasoning.

Statement-3 : Square of an odd number is an odd number.

Proof : Let n be an odd number then

$$n = 2k + 1$$

(By the definition of odd numbers we know this)

On squaring both sides,

$$n^2 = (2k + 1)^2$$

$$(2k + 1)^2 = 4k^2 + 4k + 1$$

$$= 2(2k^2 + 2k) + 1 \text{ (Since, } 2k^2 + 2k \text{ is also an integer, so say } b = 2k^2 + 2k)$$

$$= 2b + 1$$

$$\text{So } n^2 = 2b + 1$$

Since $2b$ is an even number therefore $2b + 1$ will be an odd number.

Clearly, square of an odd number is an odd number.

Statement-4 : Prove that $\sqrt{2}$ is irrational.

To prove this statement first of all we will assume that $\sqrt{2}$ is rational. By the use of definition of rational numbers we will reach the conclusion that $\sqrt{2}$ is not a rational number. By this, $\sqrt{2}$ will be proved as irrational number.

Let us consider the proof of this statement.

Proof : Let us take the adverse of statement as true, that is, $\sqrt{2}$ is a rational number. Then according to definition of rational number,

$$\sqrt{2} = \frac{a}{b} \text{ where } a, b \in I, b \neq 0 \dots\dots\dots(1)$$

a and b are also prime.

On squaring both side in (1)

$$\begin{aligned} (\sqrt{2})^2 &= \left(\frac{a}{b}\right)^2 \\ 2b^2 &= a^2 \dots\dots\dots(2) \end{aligned}$$

$$2m = a^2 \text{ where } m = b^2, m \in I$$

$2m = (2n)^2$ Where $a = 2n, n \in I$ (If a^2 is an even number then a which is an integer will also be even)

Now, on putting value of a in equation (2).

$$2b^2 = (2n)^2 \Rightarrow b^2 = 2n^2 \text{ (Suppose that } n^2 = p \text{ is any integer)}$$

$$\therefore b^2 = 2p \text{ where } p \in I$$

(So, b^2 is an even number therefore b which is an integer will also be an even number)

$$\Rightarrow b = 2q \text{ where } q \in I$$

It means, a and b have at least one common factor, therefore a and b are not coprime. But this contradicts the fact that a and b are coprime. So this proves that $\sqrt{2}$ is an irrational number.

So, we conclude that $\sqrt{2}$ is irrational.

This method of verification is called proof by contradiction. In this method we assume that the contradictory statement of the given statement is true and then we logically try to prove the assumption wrong. As a result, the actual statement is proven true. Thus, this

method is often used to prove statements. As you may have understood, we assume the negation as true.

Negating a statement is called negation. For this we use a special symbol. Negation of statement P is denoted by $\sim P$ (it means tilde P).

Lets consider some examples:-

1. P : x and y both are integers.

$\sim P$: both x and y are not integers.

2. B : Line segment AB is perpendicular on line segment PT.

$\sim B$: Line segment AB, is not perpendicular on line segment PT.

Try These

State the negations for the following statements.

1. C : A tangent intersects a circle at one point.

2. D : Arithmetic mean is greater than geometric mean.

3. R : $b^2 - a^2$ is a negative number.

Testing of Statements : Sometimes, it is not to easy to find logic while deducing statements and not easy to prove them. Sometimes statements are not correct and have to be proved false. How do we go ahead to prove a mathematical statement as false?

Statement-5 : All prime numbers are odd.

We find that it is difficult to find a logical connection in this statement because there is no fixed pattern to finding prime number. It is clear that it is not possible to examine truth criteria for infinite prime numbers. But if we find any prime number which is not odd, then this statements proved false. There is a counter example. 2 is one prime number which is not odd. So given statement is false.

Find counter examples for following statement.

Statement-6: $\forall x \in \mathbb{R}$ if x^2 is a rational number then x is also a rational number. In this statement, if $x^2 = 2$ which is a rational number then we will get $x = \sqrt{2}$ which is not a rational number. So, only one example has proved this statement false. We can find more examples for this.

Notice that a statement can be disproved by just one counter example. Because in mathematics, a statement is generally accepted if and only if it is valid in every situation. Therefore, if a statement is disproved in a situation, then it is false. This is said to be disproving by counter example.

Try These

Find one or more counter examples for the statements and disprove them.

- Product of any two positive rational numbers is greater than both the rational numbers.
- All similar figures are also congruent.

Example-2. Prove that $2k + 7$ is an odd integer where k is any integer.

Solution : If n is an odd integer, then we can express $n = 2k + 1$ where k is any integer.

We have to prove that $n = 2k + 7$ is an odd integer $\forall k \in \mathbb{I}$

$$\begin{aligned} n &= 2k + 7 \\ &= 2k + 6 + 1 \\ &= 2(k + 3) + 1 \end{aligned} \quad \text{-----(1)}$$

$$\text{Let } k + 3 = m \quad \forall m \in \mathbb{I} \quad \text{-----(2)}$$

By (1) and (2) $n = 2m + 1$

$n = 2m + 1$ is an odd integer $\forall m \in \mathbb{I}$ (According to definition of odd numbers)

Clearly $2k + 7$ is an odd integer.

Exercise - 2

1. Use mathematical symbols to write the following statements
 - A. Integers are closed under multiplication.
 - B. The subtraction of rational numbers is not commutative.
2. Give the answer on the basis of instructions for the mathematical statements.
 - A. Statements : $n^3 \geq n \quad \forall n \in \mathbb{Q}$
 - (i) Write this statement in words.
 - (ii) Is this statement true?
 - (iii) For which numbers is the statement true.
 - (iv) Can we take $n = \frac{\sqrt{2}}{7}$ in this statement?
 - B. $x^2 = 1 \Rightarrow x = 1$
 - (i) Write this statement in the form of 'if-then'.
 - (ii) Is this statement true?
 - (iii) Is statement true if when $x \notin \mathbb{N}$
3. State whether the following statements are true or false. Give the reason for your answers:-
 - (i) All polygons are pentagons.
 - (ii) All hexagons are polygons.
 - (iii) All even numbers are not divisible by 2.
 - (iv) Some real numbers are irrational.
 - (v) All real numbers are not rational.
4. It is given that ABCD is a parallelogram and $\angle B = 80^\circ$, then what can you say about other angles of the parallelogram?

5. Prove that $4m + 9$ is an odd integer where m is an integer.
6. Write negation for following statements by using appropriate symbols:-
- A. M : $\sqrt{7}$ is an irrational number.
 - B. A : $6 + 3 = 9$
 - C. D : Some rational numbers are integers.
 - D. P : Triangle PQR is equilateral.
7. Find logical connections in the following statements and write them by using (\Rightarrow) :-
- A. A : All interior angles of a triangle ΔABC are equal.
B : Triangle ΔABC is an equilateral triangle.
 - B. T : $P(a) = 0$
S : $(x - a)$ is a factor of the polynomial (x)
 - C. P : x and y are two odd numbers.
Q : $x + y$ is an even number.

Contrapositive

Some statements are difficult to prove. In given form, consider the following statements:-

A_1 : If two triangles are not similar then they are also not congruent.

This statement can also be written as:-

A_2 : If two triangles are similar then they are also congruent.

A_3 : If two triangles are not congruent, they are also not similar.

A_4 : If two triangles are congruent then they are also similar.

Now explain, which are comparable statements in the four statements given above? Obviously statements A_1 and A_4 are comparable statements, because these two statements logically express the same fact and this is their contrapositive form.

Although statements A_1 and A_4 logically express same fact but in statement A_4 it is easy to find logic and use it as compared to statement A_1 . Statement A_4 is contrapositive form of statement A_1 . So, to prove some statements we have to convert them into contrapositive form.

Example-3. Write contrapositive form for the following statements:-

If a number is divisible by 25 then it is also divisible by 5.

Solution : If a number is not divisible by 5 then it is also not divisible by 25.

Example-4. If $x^2 - 6x + 5$ is even, then x is odd. Where $\forall x \in \mathbb{Z}$

Solution : Let us express this statement in contrapositive form.

If x is not odd, then $x^2 - 6x + 5$ is not even. $\forall x \in \mathbb{Z}$

Now x is not odd $\Rightarrow x$ is even

$x = 2k, k \in \mathbb{Z}$ (According to definition of even integers)

$$x^2 - 6x + 5 \Rightarrow (2k)^2 - 6(2k) - 6(2k) + 5$$

$$\Rightarrow 4k^2 - 12k + 4 + 1 \Rightarrow 2(2k^2 - 6k + 2) + 1$$

$$\Rightarrow 2b + 1 \text{ where } b = 2k^2 - 6k + 2 \text{ and } b \text{ is an integer } (b \in \mathbb{Z})$$

According to definition of odd integers we can say that $2b + 1$ is an odd integer.

It means, if x is not odd, then $x^2 - 6x + 5$ is not even

Exercise - 3

1. Prove that the sum of interior angles of a polygon with n sides whose all angles are equal is $n \left[180 - \frac{360}{n} \right]^\circ$ where $n \geq 3$.
2. Prove that the sum of n term of an A.P. is $3p^2 + 4p$, if the n^{th} term of that AP is $6n + 1$.
3. Prove that the sum of three successive even integers is always a multiple of 6.
4. Prove that 8 is a factor of $(2n + 3)^2 - (2n - 3)^2$, where n is a natural number.
5. Prove that if the sum of squares of two successive whole numbers is divided by 4, then remainder always comes as 1.

What We Have Learnt

1. For proving statements:-
 - (i) We use previously proved theorems, definitions and axioms.
 - (ii) Each statement of proof logically connects with the earlier statements.
 - (iii) During the writing of statements we use specific symbols so that large sentences can be written in brief.
2. We can write brief, clear and exact mathematical statements by using mathematical language.

\forall, \in, \cong etc. are some symbols of mathematical language.
3. Methods of proving mathematical statements are:-
 - (i) Deductive - reasoning.
 - (ii) By counter example.

Answer Sheet

Exercise - 1

- | | | |
|--------------|--------------|------------|
| 1. (i) False | (ii) True | (iii) True |
| (iv) Flase | (v) False | (vi) False |
| (vii) True | (viii) False | (ix) True. |

2. (i) $\Delta RST \cong \Delta XYZ$ (By Statement-4)
 (ii) $AB > AC$ (By statement-1)
 (iii) $l = m$ (By statement-5)
 (iv) ΔDEF is a scalene triangle (By statement-2)
 (v) $141 = 2 \times 70 + 1$ (By statement-3)
3. (i) $n_1 = 2k_1, n_2 = 2k_2$
 (ii) $n_1 \times n_2 = (k_1 \times k_2)$
 (iii) $n_1 + n_2 = 2(k_1 + k_2)$
 (iv) $n_1 + n_2 = 2(k_1 \times k_2) = 2k$, according to definition of even numbers.
 (v) Even number.
4. In all (i), (ii), (iii) $a \neq 0$
5. (ii) No (iii) Yes (iv) $a = 5$ is not valid
 (v) $q \in I - \{5, -5\}$

Exercise - 2

1. (i) $a \cdot b = c \forall a, b, c \in I$ (ii) $p - q \neq q - p \forall p, q \in Q$
2. A. (i) Cube of a rational number is greater than that number
 (ii) No
 (iii) True for $n \in N$
 (iv) No
 (v) No, cube of a negative number is smaller than that number.
- B. (i) If square of a number is 1, then the value of that number will be 1.
 (ii) Yes
 (iii) No
3. (i) False (ii) True (iii) False (iv) True (v) False
 (vi) False
4. $\angle A = 100^\circ, \angle C = 100^\circ, \angle D = 80^\circ$.
6. (i) $\sim M: \sqrt{7}$ is not an irrational number
 (ii) $\sim A: 6 + 3 \neq 9$
 (iii) $\sim D: \text{Some rational numbers are not whole numbers.}$
 (iv) $\sim P: \text{Triangle PQR is not equilateral.}$
7. (i) $A \Rightarrow B, B \Rightarrow A$ (ii) $S \Rightarrow T, T \Rightarrow S$ (iii) $P \Rightarrow Q$



SURFACE AREA AND VOLUME OF SOLIDS

Introduction

We live in a three dimensional world. If we can see and touch a 3-D figure then we can measure its length, breadth and height. Many times we need to measure some other aspects of these figures such as volume, area etc. For example, while buying-selling land we need to know the area; to know how much material is needed to make a statue we need to know the volume etc.

Before we learn how to find the area and volume of 3-D shapes, let us open them up.

Surface Net for Making 3-D Shapes

Kamli and Mangi had a cubical box made of cardboard. They cut the edges of the box using a pair of scissors as shown in figure –1 and spread it out (figure–2). They discussed with each-other about the shape of the open box. After some time, they joined the edges of the box again using cello-tape and were very happy. They showed the box to Mangi’s father and talked about what they had done.

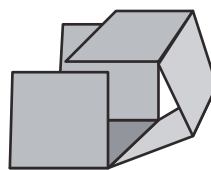

Figure - 1

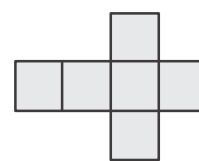

Figure - 2

Mangi’s father was very pleased with their work. He asked if the box could be opened in any other way. Kamli and Mangi opened up the box in a different way and got the shape shown in figure–3. They immediately tried to make the box again using the new shape.

Mangi’s father asked the two children to cut one corner of the cubical box to make other open shapes. The children made the shapes shown below.

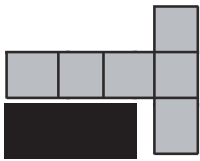

Figure - 3

Mangi's father discussed different ways of getting various shapes. In this activity, we saw that when we cut along the edges of a cubical cardboard box and spread it out, we can have many different shapes. These flat figures are known as surface net of cubes. The surface

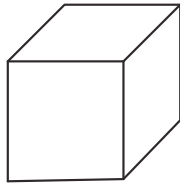

Figure - 4

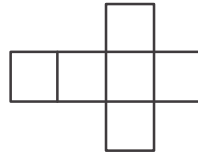

Figure - 5

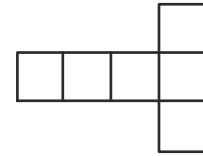

Figure - 6

net of a three dimensional figure is two dimensional. Figures-5 and 6 represent two surface nets of the same cube. Can we obtain more surface nets for this cube?

Try These



1. Take several cubical cardboard boxes and open them in various ways by cutting their edges. How many different open flat figures did you get?
2. Draw the surface net for a cube. We can get 11 different surface nets for a single cube.
How many surface nets are possible for a cuboid?
3. Using cardboard, prepare a cubical box with sides equal to 4 cm.
4. Using cardboard, prepare a cuboidal box with sides equal to 12 cm, 6 cm and 8 cm.

Parts of a Cube and Cuboid

(i) Face, Edge and Vertex

We have already learnt about cube, cuboid and cylinder in previous classes. In this chapter we will learn about different parts of cubes and cuboids.

Explore

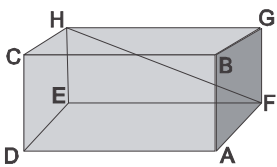

Figure - 7

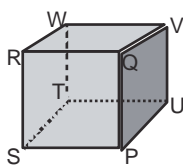

Figure - 8

See the figures of cube and cuboid given below. Here ABCDEFGH is a cuboid and PQRSTU VW is a cube. The nomenclature cube and cuboid is based on the vertices of the figure.

Can you count the faces, edges and vertices of the cube and cuboid and name them?

What is the relation between the faces and vertices of a cube and a cuboid?

Look carefully at figures-7 and 8 and discuss with your friends. Write your answers in your notebook. Some points related to ABCDEFGH are given below:

- The cuboid has 8 vertices and these are A, B, C, D, E, F, G and H
- A cuboid has 12 edges. Opposite edges in a cuboid are equal. For example, in the cuboid given to us edges AB and CD and EF and HG are equal.
- A cuboid has six faces. In the given figure, the six faces are ABCD, EFGH, AFGB, DEHC, AFED and BGHC. ABCD and EFGH are equal to each other. Similarly, AFGB and DEHC are equal.

Look at figures-7 and 8 and tell which of the edges are equal and which of the faces are equal.

(ii) Diagonal of a Cube and Cuboid

A teacher asked her students: What is the shape of a chalk box or a classroom? All the students answered that they are like cuboids. Then the teacher called five students and asked them to place a pencil inside the chalk box. The students found out that the pencil did not fit in the box if it was laid flat on any of the faces.

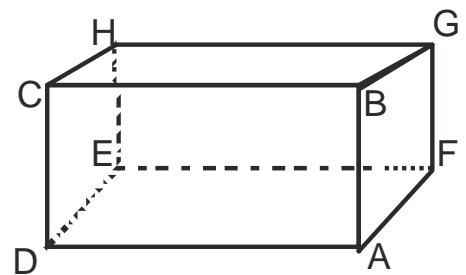

Suppose ABCDEFGH is a chalk box. If we try to place the pencil flat on face ADEF (the bottom of the box), it will not fit because the length of the pencil is more than the length of the box. So, does this mean that the pencil cannot be put inside the box? What if we put the pencil in such a way that its ends are towards A and E or D and F? If we put the pencil on ADEF in such a way that it lies along AE or DF then it is possible that the pencil may fit in the box because the length of AE and DF is more than the lengths AD or DE.

(Take another cuboidal box.) If the pencil still does not fit after placing it along AE then is there any other way to place the pencil in the box so that it fits?

If we put the pencil in such a way that its ends are on H and A or G and D then it more probable that the pencil would fit in the box. This means that this distance is the longest length inside the box. These lengths (AH and GD) are the space diagonals of the given cuboid. In cuboid ABCDEFGH, the space diagonals are AH, GD, FC and EB. The distance between two opposite vertices of any face of the cuboid is called face diagonal.

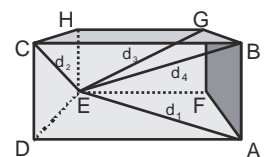

Figure - 9

Now the teacher asked the students to look at figure-9 and then take a cuboidal box and measure the lengths corresponding to d_1 , d_2 , d_3 and d_4 in the figure using a thread.

Which of the lengths is longest? What will we call these distances?

d_1 , d_2 , and d_3 are the diagonals but what is d_4 ? Can we call it a diagonal? It is also a diagonal but different from other three because it does not lie along any of the faces of the cuboid.

Thus, d_1 , d_2 , d_3 and d_4 are all diagonals but of two different types. d_1 , d_2 , and d_3 lie along the face of the cuboid and are known as face diagonals while d_4 is present inside the space and is called diagonal of cuboid or space diagonal.

Face and Space Diagonal

If we look at the cardboard box we will find two types of diagonals – one type along the faces of the cuboid and the other type which covers the entire cuboid. The diagonals on the face of the cuboid are called face cuboids and the one which is present inside the three dimensional space of the box is called space diagonal.

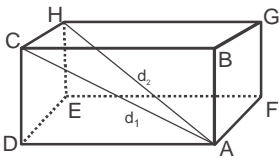

Figure - 10

In geometry, the face diagonals of a cube or cuboid are line segments which connect the vertices on the same face while space diagonal connects vertices of different faces. In the given diagonal (figure-10), AH is space diagonal of the cuboid while AC is a face diagonal.

We can obtain 16 diagonals in a cube or cuboid of which 12 are face diagonals and 4 are diagonals (or space diagonal) of the cuboid.



Try These

Draw a cube and cuboid and name their diagonals. Separately count the diagonals for the cube and cuboid and see how many are face and how many are space diagonals.

FINDING OUT THE DIAGONAL OF CUBE AND CUBOID

Cuboid

Given a room, we have to place a bamboo which is longer than its height, breadth or length inside it. Suppose we know the length, width and height of the room and also the length of the bamboo then can we find out whether the bamboos would fit in the room or not? How can we find the maximum length of any object so that it can fit in the room? That is, we need to know the relation between the space diagonal and length, width and height of a box to know the maximum length of any pencil, twig, or piece of paper which can be fitted inside it.

We have already studied about cube, cuboid and their diagonals. Now we need to find out how to calculate the length of diagonals given the sides of a cube or cuboid.

Face Diagonal

How will we find out the length of a face diagonal?

We know that $\triangle ADC$ is a right angled triangle in which $AD = a$ unit or $DC = c$ unit.

Therefore by Bodhayan-Pythagoras theorem:

$$AC = \sqrt{AD^2 + DC^2}$$

$$d_1 = \sqrt{a^2 + c^2}$$

Thus, length of face diagonal = $AC = \sqrt{a^2 + c^2}$ unit

Similarly we can find out lengths of face diagonals AE or AG

$$AE = d_2 = \sqrt{a^2 + b^2} \text{ unit}$$

$$AG = d_3 = \sqrt{b^2 + c^2} \text{ unit}$$

Hence, the cuboid in which all the sides are of different lengths have diagonals of three different lengths.

Diagonals of a Cuboid

In the given cuboid (Figure-11) the lengths of sides are a units, b units and c units respectively. AH is one of the diagonals of the cuboid.

In the figure-11, AE is a face diagonal and its length is $\sqrt{a^2 + b^2}$ unit

In a right angled triangle (Figure-12). We can calculate the length of the diagonal AH by Bodhaya-Pythagoras theorem.

$$\begin{aligned} AH &= \sqrt{AE^2 + EH^2} \\ &= \sqrt{(a^2 + b^2) + c^2} \\ &= \sqrt{a^2 + b^2 + c^2} \end{aligned}$$

\therefore the length of the diagonal, $AH =$

$$= \sqrt{a^2 + b^2 + c^2} \text{ unit}$$

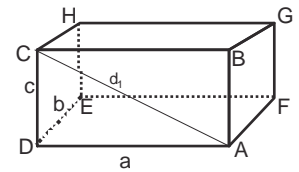

Figure - 11

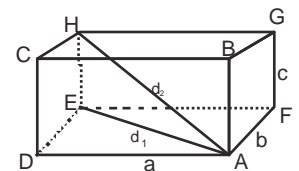

Figure - 12



Hence, length of the space diagonal = $\sqrt{(\text{Length})^2 + (\text{Width})^2 + (\text{Height})^2}$ Unit

Are the lengths of the other 3 space diagonals same? Identify these diagonals.

Diagonals are,, and

Find their lengths by using the Bodhayan-Pythagoras theorem.

Cube

If a side of given cube is 'a' units then length of the face diagonal = $\sqrt{a^2 + a^2}$

$$= \sqrt{2a^2}$$

$$= a\sqrt{2} \text{ Units}$$

All the face diagonals of the cube are of same length.

$$\text{Space diagonal of the cube} = \sqrt{a^2 + a^2 + a^2}$$

$$= \sqrt{3a^2}$$

$$= a\sqrt{3} \text{ इकाई}$$

Example-1. In a cuboid, the length is 10 cm, breadth is 4 cm and height is 5 cm. Find the length of the space diagonal of the cube.

Solution : Length, breadth and height of the cuboid is given, we have to calculate the length of the space diagonal of the cuboid.

We know that

$$\text{Diagonal of the cuboid} = \sqrt{(\text{Length})^2 + (\text{Width})^2 + (\text{Height})^2}$$

$$= \sqrt{(10)^2 + (4)^2 + (5)^2}$$

$$= \sqrt{100 + 16 + 25}$$

$$= \sqrt{141}$$

$$= 11.87 \text{ cm}$$

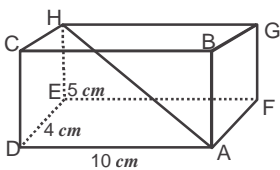

Figure - 13

Hence, the length of the space diagonal of given cuboid is 11.87 cm.

Example-2. Calculate the lengths of face diagonal and space diagonal of a cube having each side equal to 6 cm.

Solution : Side of the cube is 6 cm (given). We have to calculate the length of space diagonal of the cuboid.

We know that face diagonal of the cuboid = $a\sqrt{2}$ unit where a is the side of the cube.

$$\text{Hence, face diagonal of the cube} = 6\sqrt{2} \text{ cm}$$

$$\text{Since space diagonal of the cube} = a\sqrt{3} \text{ unit}$$

$$\text{Hence, diagonal of the cube} = 6\sqrt{3} \text{ cm}$$

Exercise-1

1. A cuboid is of length 8 m, breadth 4 m and height 2 m. Calculate the lengths of all the diagonals.
2. Calculate the length of face diagonal of the cube whose side is $12\sqrt{3}$ cm long. What is the length of the space diagonal of that cube?
3. Calculate the length of the possible longest pole which can be placed in a room of length 10 m, width 10 m and height 5 m.



Cylinder

Cylinder is a 3-dimensional figure in which 2 similar and congruent circular surfaces are joined to each other with the help of a curved surface.

Pipes, tubelight, etc. are some examples of cylinders.

The perpendicular distance between the circular surfaces is called the height of the cylinder and the circular surface is called base of the cylinder. The line segment which joins the centers of the two circular surfaces (base) is called axis of the cylinder.

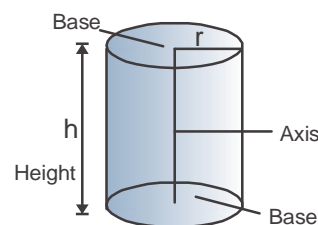
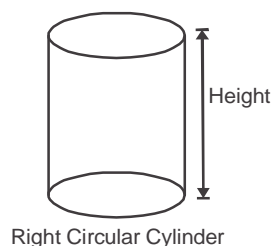

Figure - 14

Types of Cylinder

Right Circular or Oblique Cylinder

When the two bases lie exactly over each other and the axis is perpendicular to the base then the cylinder is called a right circular cylinder. If the base of the right circular cylinder is slightly shifted so that axis is no longer perpendicular to the base then it becomes an oblique cylinder (Figure-16).



Right Circular Cylinder

Figure - 15

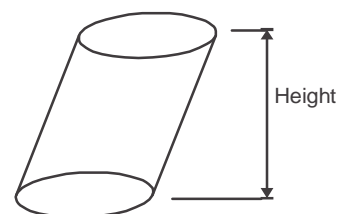

Oblique Cylinder

Figure - 16

Net of Cylinder

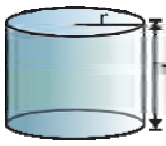

Figure - 17



Figure - 18

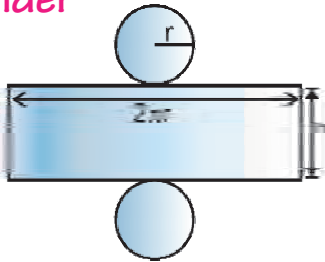

Figure - 19

Take one cylinder where both ends are closed. Let the radius of this cylinder be 'r' and height be 'h' units. When we cut the **curved** surface of the cylinder and spread it out (figures- 18, 19) then we obtain the surface net of the cylinder.

In the net obtained of cylinder, the length of rectangle (curved surface of cylinder) is $2\pi r$ unit and breadth is (height of cylinder) h units. The radii of the two circles is 'r' unit.



Try These

1. Make the net of a cylinder whose height is 7 cm and radius of base is 2 cm.
2. Take a sheet of drawing paper and make a cylinder of height 7cm and radius 2 cm.

Surface Area of Right Circular Cylinder



Figure - 20 (i)

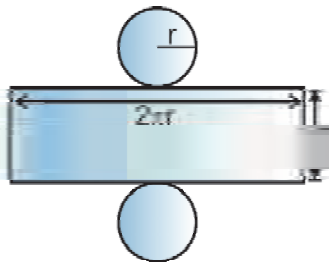

Figure - 20(ii)

The net diagram of a cylinder of radius 'r' and height 'h' will look similar to the one given in figure 20(ii). In this example, the width of rectangle is equal to the height of cylinder, h and length of rectangle is equal to circumference of the circle, $2\pi r$.

Hence, area of the curved surface of cylinder = Area of rectangle

$$= 2\pi r h \text{ unit}$$

And total surface area of the cylinder = Area of curved Surface + Area of both bases

$$= 2\pi r h + \pi r^2 + \pi r^2$$

$$= 2\pi r h + 2\pi r^2$$

$$= 2\pi r(h + r) \text{ Square unit}$$

Where r is radius of circular base and h is height of cylinder.

Volume of a Right Circular Cylinder

We know that volume of a cuboid is can be obtained by multiplying its height with the area of its base. The shape given in figure-21 is a cuboid. If we increase the number of sides from 4 to 5 and so on we can see a **gradual** change in shape from figure-21 to figure-22. You will

observe that it will change slowly into a right circular cylinder because the base is gradually becoming circular. When the number of sides becomes infinite then this base changes into a circle and the whole figure becomes a right circular cylinder.

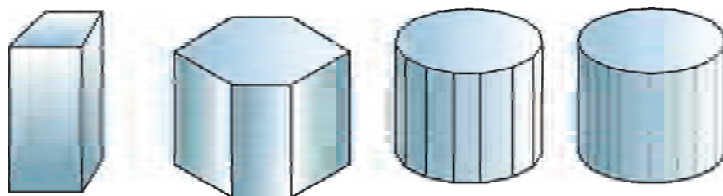

Figure - 21

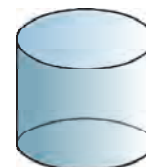

Figure - 22

Therefore, we can say that we can obtain the formula of volume of a cylinder from that of a cuboid. Volume of cylinder is the product of the area of its base and its height.

Let ' r ' be the radius of the base and ' h ' be the height, then

$$\begin{aligned}\text{Volume of cylinder} &= \text{Area of its base} \times \text{height} \\ &= \pi r^2 \times h \\ &= \pi r^2 h \text{ unit cube}\end{aligned}$$

Try These

1. Take a sheet of paper. Make a cylinder by folding it along its length. Find the area and volume of the figure obtained. Now fold the same sheet along its breadth and find the area and volume. What can you say about the obtained volume and area?
2. Take some Rs. 5/- coins and form stacks of different heights by arranging them one above the other. Now, calculate the area and volume of the obtained figures. How many techniques can be used to calculate the area and volume?



Calculation of Curved Surface and Volume

Often cylindrical vessels are used to measure volumes. At other times we have to calculate how much metal is needed to make a cylinder or what is the amount of paint needed to colour a cylindrical surface? Or, how much paper is needed to cover it completely? For all of this we have to calculate the curved surface area and volume of cylinders. Let us see how this can be done.

Example-3. The circumference of the base of a right circular cylinder is 44 cm. If the height of the cylinder is 10 cm, calculate the curved surface area and volume of the cylinder.

Solution : Let's ' r ' be the radius of the base of a cylinder and ' h ' its height.

Given, height of cylinder, $h = 10 \text{ cm}$.

Circumference of the base of cylinder $2\pi r = 44 \text{ cm}$

$$r = \frac{44}{2\pi}$$

$$r = \frac{44}{2} \times \frac{7}{22}$$

$$r = 7 \text{ cm}$$

Area of curved surface of cylinder $= 2\pi rh$

$$= 2 \times \frac{22}{7} \times 7 \times 10$$

Area of curved surface of cylinder $= 440 \text{ sq.cm}$.

Volume of cylinder $= \pi r^2 h$

$$= \frac{22}{7} \times 7 \times 7 \times 10$$

Volume of cylinder $= 1540 \text{ cm}^3$.

Example-4. Two right circular cylinders of same height have their radii in the ratio 3:4. Find the ratio of the volumes of the cylinders.

Solution : Let the radius of the cylinders be r_1 and r_2 respectively and height be h (Why?)

Because, the ratio of the radii of cylinders is 3:4,

$$\therefore \frac{r_1}{r_2} = \frac{3}{4}$$

Or $r_1 = 3r, r_2 = 4r$ (Why?)

Hence, volume of first cylinder $= \pi r_1^2 h$

And, volume of second cylinder $= \pi r_2^2 h$

\therefore Ratio of volumes of both cylinders, $\frac{\pi r_1^2 h}{\pi r_2^2 h} = \frac{r_1^2}{r_2^2}$

$$\frac{\pi r_1^2 h}{\pi r_2^2 h} = \frac{(3r)^2}{(4r)^2}$$



$$= \frac{9r^2}{16r^2}$$

$$= \frac{9}{16}$$

Example-5. For a science project, Aisha has to make kaleidoscope with chart paper so that its surface is cylindrical. What would be the area of chart paper required by her if radius of kaleidoscope is 2.1 cm and height is 20 cm ?

Solution : Given

Radius of Kaleidoscope, $r = 2.1 \text{ cm}$.

Height of Kaleidoscope, $h = 20 \text{ cm}$.

Required Area of chart paper = Area of Kaleidoscope

$$= 2\pi rh$$

$$= 2 \times \frac{22}{7} \times 2.1 \times 20$$

$$= 264 \text{ sq.cm}$$



Exercise - 2

- Radius of the base of a cylinder is 14 cm and its height is 10 cm . Find the area of the curved surface and total surface area of the cylinder.
- The area of curved surface of cylinder is 3696 sq.cm . If the radius of the base of cylinder is 14 cm then find the height of the cylinder.
- Area of curved surface of a cylinder, whose height is 14 cm , is 88 sq.cm . Find the diameter of the cylinder.
- Diameter and height of a cylindrical pillar are 50 cm and 3.5 m respectively. Find the cost of painting the curved surface of pillar at a rate of Rs. 12.50 per m^2 .
- The diameter of a roller is 84 cm and its length is 120 cm . It takes 500 complete revolutions of the roller to level a playground once. Find the area of the playground in m^2 .
- Find the volume of cylinder if its radius is 3 cm and height is 14 cm .
- The area of the base of a cylinder is 154 sq.cm . and height is 10 cm . Find the volume of the cylinder.
- The circumference of the base of a cylinder is 88 cm and height is 10 cm . Find the volume of the cylinder.

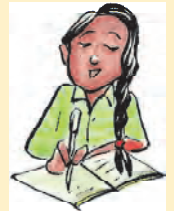

9. Volume of a cylinder is 3080 cm^3 and its height 20 cm . Find the radius of the cylinder.
10. 11 l juice is filled in a cylindrical vessel of height 35 cm . Find the diameter of the jar. ($1 \text{ l} = 1000 \text{ cm}^3$)
11. A thin cylindrical tin contains 1 litre paint. If diameter of the tin is 14 cm then what is the height of the tin?
12. A patient in a hospital is given soup daily in a cylindrical bowl of diameter 7 cm . If the bowl is filled with soup to a height of 4 cm , how much soup the hospital has to prepare daily to serve to 50 patients?
13. A 18 m long thin wire is drawn by melting a copper rod of diameter 1 m and length 8 m . Calculate the thickness of the wire.
14. A well has been dug whose radius is 7 m and which is 20 m deep. A $22 \text{ m} \times 14 \text{ m}$ platform has been constructed from the soil excavated when digging the well. Find the height of the platform.
15. How many coins of diameter 1.75 cm and thickness 2 cm can be made by melting down a cuboid of sides 5.5 cm , 10 cm and 3.5 cm ?
16. Volume and curved surface of a cylinder are 24750 cm^3 and 3300 cm^2 respectively. Find the height and radius of the base of cylinder.

Cone

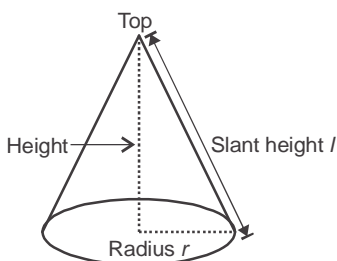

Figure - 23

Cone is a 3-dimensional shape with a circular base and a pointed top. The top and base are connected by two line segments. One joins the top to the circumference of the base and this is the slant height (l) of the cone. The line segment which joins the top of the cone to the center of the base and which is perpendicular to the base is called altitude or height of the right circular cone.

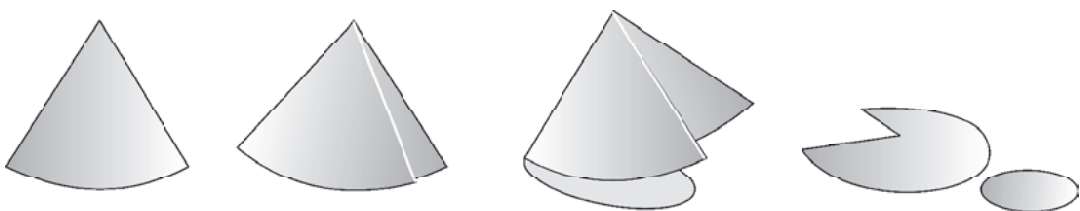

Figure - 24

1. Net of a Cone

See the pictures of the cone given below. If we cut the cone along its slant height and the edges of its base, then we will get a figure similar to the one shown in figure-25.

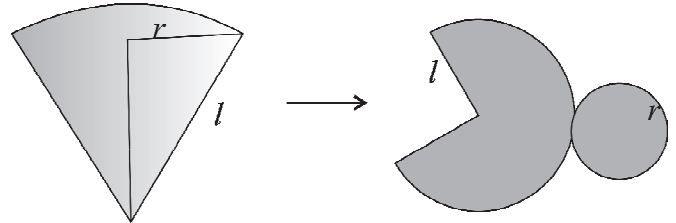

Figure - 25

In the net diagram of a cone includes a sector of radius ' l ' units and a circle of radius ' r ' units.

2. Surface Area of Cone

If ' r ' is the radius of base of a cone and its slant height is ' l ' units then to find the surface area, we have to calculate the curved surface area and surface area of the base.

We have discussed that if we cut the cone open then we obtain a curved surface.

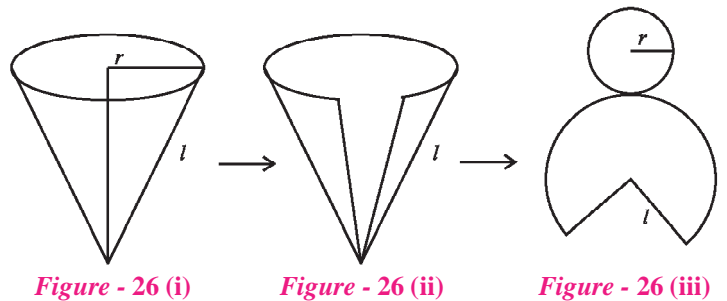

Figure - 26 (i)

Figure - 26 (ii)

Figure - 26 (iii)

To calculate the area of curved surface of the cone, we have to calculate the area of the sector obtained in the net diagram.

$$\begin{aligned} \text{Curved surface area of cone} &= \text{Area of the sector of a circle of radius } 'l' \text{ unit} \\ &= \frac{1}{2}(2\pi r)l \\ &= \pi r l \text{ sq. unit} \end{aligned}$$

$$\begin{aligned} \text{Area of the base of the cone} &= \text{Area of a circle having radius } 'r'. \\ &= \pi r^2 \text{ sq. unit} \end{aligned}$$

$$\begin{aligned} \text{Total surface area of a cone} &= \text{Curved surface area} + \text{Area of the base of the cone} \\ &= \pi r l + \pi r^2 \\ &= \pi r(r + l) \end{aligned}$$

Hence, the total surface area of the cone where radius of base is ' r ' and slant height is l is $\pi r(r + l)$.

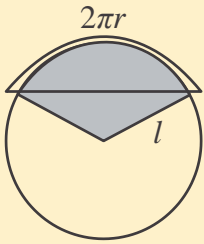
**NOTE:**

In the cone given above, the circumference of the circular base is $2\pi r$. This is the sector of a circle in which radius is l unit. We know that ratio of the area of the shaded region and area of the circle will be same as the ratio of the length of arc of sector to the circumference of the circle.

This means that,

$$\frac{\text{Area of the Sector of a Circle}}{\text{Area of Circle}} = \frac{\text{Length of Arc of Sector}}{\text{Circumference of Circle}}$$

$$\frac{\text{Area of the Sector of a Circle}}{\pi l^2} = \frac{\text{Length of Arc of Sector}}{2\pi l}$$

$$\text{Area of the Sector of a Circle} = \frac{\text{Length of Arc of Sector} \times \pi l^2}{2\pi l}$$

$$\text{Area of the Sector of a Circle} = \frac{\text{Length of Arc of Sector} \times l}{2}$$

$$\text{Area of the Sector of a Circle} = \frac{2\pi r \times l}{2}$$

$$\text{Area of the Sector of a Circle} = \pi r l$$

Where, $2\pi r$ is length of the arc of sector of a circle and l is radius of the circle.

3. Volume of Cone

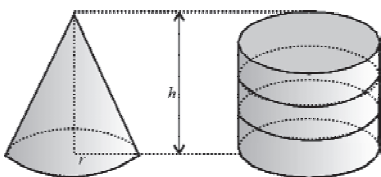

Figure - 28

Let us do an activity to understand the relation between the volumes of a cone and a cylinder.

Make a cylinder and a cone having the same base and of same height.

Fill the cone with sand and then put it sand in the cylinder. Is the cylinder completely filled with sand?

To completely fill the cylinder with the sand, how many times did you repeat this process?

In this way you will find out that if the area of the base of cone and cylinder is same and they are of the same height then volume of the cylinder is thrice the volume of the cone.

$$\therefore 3 \times \text{volume of cone} = \text{volume of cylinder}$$

$$\text{Volume of cone} = \frac{1}{3} (\text{Volume of cylinder}) = \frac{1}{3} (\text{Height} \times \text{Area of base})$$

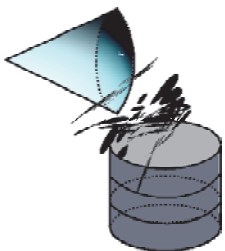

Figure - 29

Since volume of cone is the product of its height and the area of its base, therefore.

Volume of cone $= \frac{1}{3} \times A \times h$ where A is the area of base and h is height of the cylinder.

Area of base $A = \pi r^2$

Hence, volume of cone $= \frac{1}{3} \times \pi r^2 h$ *Cube unit*

Volume of cylinder, in which r is the radius of the base and h is the height is $\pi r^2 h$.

Hence, volume of cone is one third of volume of cylinder given that radius of the base and height are same for both the figures.

Example-6. Diameter of a cone is 12 cm and its height 8 cm. Find the curved surface area and volume of cone.

Solution : Let r be the radius and h be height and l be the slant height of the cone.

Given: Height of cone $= h = 8$ cm.

Diameter of cone $= 2r = 12$ cm.

Radius of cone $r = 6$ cm.

$$\begin{aligned} \text{Slant height of cone, } l &= \sqrt{h^2 + r^2} \\ &= \sqrt{8^2 + 6^2} = \sqrt{64 + 36} \\ &= \sqrt{100} = 10 \text{ cm} \end{aligned}$$

$$\begin{aligned} \text{Curved surface area of cone} &= \pi r l \\ &= \pi \times 6 \times 10 = 60\pi \text{ वर्ग सेमी.} \end{aligned}$$

$$\begin{aligned} \text{Volume of Cone} &= \frac{1}{3} \pi r^2 h \\ &= \frac{1}{3} \times \pi \times 6 \times 6 \times 8 \\ &= 96\pi \text{ cm}^2 \end{aligned}$$



Example-7. 65π square meter cloth is used to make a tent in the shape of a cone. Slant height of tent is 13m, find its height and radius.

Solution : Let radius be r , h be height and l be slant height of the cone.

Given: Slant height of cone, $l = 13$ m.

Area of the cloth which is used in cone shaped tent is equal to the curved surface area of cone (Why?). Therefore,

Curved surface area of cone $= 65\pi$

$$\pi r l = 65\pi$$

$$r = \frac{65\pi}{\pi l}$$

$$r = \frac{65}{13}$$

$$r = 5 \text{ meter}$$

$$\text{Slant height, } l = \sqrt{h^2 + r^2}$$

$$l^2 = h^2 + r^2$$

$$h^2 = l^2 - r^2$$

$$= (13)^2 - (5)^2$$

$$= 169 - 25$$

$$h^2 = 144$$

$$h = 12 \text{ meter}$$

Radius of the base of the cone is $5m$ and its height $12m$.



Exercise - 3



- Find the curved surface area of the right circular cone in which slant height is 10 cm and radius of the base is 7 cm .
- If the curved surface area of a cone $77\pi \text{ sq.cm}$ and radius of its base is 14 cm then find the height of the cone.
- If the slant height of the cone is 21 cm and diameter of its base is 14 cm then find the total surface area of the cone.
- If the radius of the base of a cone shaped hat (like the ones worn by Jokers) is 7 cm and its height is 24 cm then find the area of the sheet needed to make 10 such hats.
- Height of a cone shaped tent is 5 m and its radius is 12 m . Find the slant height of the cone and the cost of the canvas which is used to make the tent. Cost of canvas is 70 rupees per square meter.
- Find the volume of a cone whose base area is 300 sq.cm and height is 15 cm .
- Find the height of the cone if its volume is 550 cm^3 and its diameter is 10 cm .
- The circumference of the base of a cone shaped cup is 22 cm and height is 6 cm . Then what is the maximum volume of water which can be kept in it.
- If the radius of a 1 m long metallic rod (in cylindrical shape) is 3.5 cm then how many cones of radius 1 cm and height 2.1 cm can be formed by melting down the rod?

10. We have a right angled triangle having sides 21 cm, 28 cm and 35 cm. If we take the side of 28 cm as axis and rotate the triangle around it then write the name of the figure obtained and calculate its volume.
11. If the radius of the base of a cone and a cylinder and their height is similar then calculate the ratio of their volumes.

Sphere

The figure obtained by rotating a circle around its diameter is called a sphere. A sphere is a solid figure such that each point on it is equidistant from its center.



Figure - 31

Surface area of sphere

Activity-1

We know that surface area represents the outer surface of any solid figure. Let us compare the surface area of a cylinder with that of a sphere.

Take a cylinder or sphere in which the radius of the base of the cylinder and radius of sphere are same and the height of the cylinder is twice the radius of the sphere. Take a piece of rope as well

Mark a point halfway along the height of the cylinder. Now, start winding the rope starting from the bottom or the top of the cylinder and end at this point. Cut this rope and wind it around the sphere.

You will find that half of the sphere is covered by this string. Now, through this activity we can say that area of the curved surface of a cylinder is similar to the area of the sphere when radius of the base of cylinder and radius of sphere are equal and height of cylinder is equal to the diameter of sphere.

We can say that,

Surface Area of sphere = Surface area of curved part of cylinder.

$$= 2\pi rh$$

$$= 2\pi r (2r)$$

$$= 4\pi r^2 \text{ sq. units.}$$

Therefore, surface area of sphere = $4\pi r^2$ sq. unit, where r is the radius of sphere.

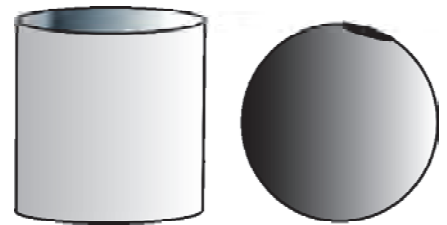

Figure - 32

Activity-2

Take a string and wind it completely around a ball making sure that no space is left in between and that there are no overlaps (see figure-33). If we make circles using this string where the radius of the circle is equal to the radius of the sphere then we will be able to make 4 circles (figure-34). Area of each circle is πr^2 .

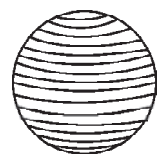

Figure - 33

$$\begin{aligned}\text{So, surface area of sphere} &= 4 \times \text{Area of circle} \\ &= 4\pi r^2\end{aligned}$$

Therefore, surface area of sphere is $4\pi r^2$ Sq.unit, where r is the radius of the sphere. Then, the surface area of hemispheres can be obtained in the following ways.

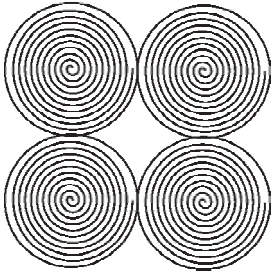

Figure - 34

$$\begin{aligned}\text{Surface Area of Hemisphere} &= \frac{1}{2} \times (\text{Surface Area of sphere}) \\ &= \frac{1}{2}(4\pi r^2) \\ &= 2\pi r^2 \\ \text{Total area of the hemisphere} &= 2\pi r^2 + \pi r^2 \\ &= 3\pi r^2 \text{ sq.unit}\end{aligned}$$

Hence,

Surface Area of Sphere	$= 4\pi r^2 \text{ sq.unit}$
Surface Area of Hemisphere	$= 2\pi r^2 \text{ sq.unit}$
Total surface area of Hemisphere	$= 3\pi r^2 \text{ sq.unit}$

Volume of Sphere

Volume of sphere is proportional to the cube of its radius. When radius is increased the volume increases correspondingly. Value of volume is represented by $\frac{4}{3}\pi r^3$.

Example-8. If the radius of a solid sphere is 7 cm , then find its surface area and volume.

Solution : Given, radius of sphere, $r = 7 \text{ cm}$.

$$\begin{aligned}\text{Surface area of sphere} &= 4\pi r^2 \\ &= 4 \times \frac{22}{7} \times (7)^2 \\ &= 4 \times \frac{22}{7} \times 7 \times 7 \\ &= 616 \text{ cm}^2\end{aligned}$$

$$\text{Volume of sphere} = \frac{4}{3}\pi r^3$$

$$\begin{aligned}
 &= \frac{4}{3} \times \frac{22}{7} \times (7)^3 \\
 &= \frac{4}{3} \times \frac{22}{7} \times 7 \times 7 \times 7 \\
 &= 1437.33 \text{ cm}^3
 \end{aligned}$$



Example-9. Find the total surface area of a hemisphere of diameter 14 cm.

Solution : Let r be the radius of hemisphere.

Given, diameter of hemisphere = 14 cm

$$\therefore 2r = 14 \text{ cm}$$

$$\text{Or } r = 7 \text{ cm}$$

$$\begin{aligned}
 \therefore \text{Total surface area of hemisphere} &= 3\pi r^2 \\
 &= 3 \times \frac{22}{7} \times (7)^2 \\
 &= 462 \text{ sq.cm}
 \end{aligned}$$

Example-10. A big sphere is made by melting down 64 small spheres each of radius 2 cm. Find the radius of the big sphere.

Solution : Let r cm is the radius of small sphere.

Given = $r = 2$ cm

$$\text{Volume of each small sphere} = \frac{4}{3} \pi r^3 = \frac{4}{3} \pi (2)^3 = \frac{32}{3} \pi \text{ cm}^3$$

$$\therefore \text{Volume of 64 small spheres} = 64 \times \frac{32}{3} \pi$$

$$= \frac{2048\pi}{3}$$

By melting down the small 64 spheres a big sphere is made. So the volume of the big sphere is equal to the combined volume of 64 small spheres. Let 'R' be the radius of the big sphere.

Volume of big sphere = Volume of 64 small sphere

$$\frac{4}{3} \pi R^3 = \frac{2048\pi}{3}$$

$$R^3 = \frac{2048\pi \times 3}{3 \times 4\pi}$$

$$R^3 = 512$$

$$R = 8 \text{ cm}$$

Hence, radius of big sphere = 8 cm.

Example-11. Radius of a solid metallic sphere is 3 cm. If the density of the metal is 8 gm/cm³ then find the mass of the metal.

Solution : We know that product of density and volume is equal to mass. Therefore, we first calculate the volume of the sphere.

Let r cm be the radius of the sphere.

$$r = 3 \text{ cm}$$

$$\begin{aligned} \text{Volume of sphere} &= \frac{4}{3} \pi r^3 \\ &= \frac{4}{3} \times \frac{22}{7} \times (3)^3 \\ &= \frac{4}{3} \times \frac{22}{7} \times 3 \times 3 \times 3 \\ &= 113.14 \text{ cm}^3 \end{aligned}$$

Because density of metal is 8gm/cm³, hence mass of 1 cm³ is 8 g.

$$\begin{aligned} \therefore \text{Mass of sphere} &= \text{Volume} \times \text{Density} \\ &= 113.14 \times 8 \\ &= 905.12 \text{ gram} \\ &= 0.9051 \text{ kg (approx.)} \end{aligned}$$

Exercise - 4



- Find the surface area of a sphere having radius equal to 21 cm.
- Diameter of a globe is 14 cm. Find its surface area.
- Surface area of a sphere is 154 sq. cm². Find the diameter of the sphere.
- Find the volume of sphere if its radius is 3 cm.
- By melting down 21 small metallic balls, each of radius 2 cm, one big sphere is made. Calculate the volume of this sphere.
- By melting down a sphere of radius 10.5 cm some small cones are made, each of height 3 cm and radius 3.5 cm. Find the number of such cones.

7. After filling the air in a spherical balloon of radius 7 cm it becomes 14 cm . Calculate the ratio of the surface area of the balloon in both conditions.
8. Calculate the volume of a sphere having surface area equal to 154 sq. cm^2 .
9. Ratio of the volume of 2 spheres is $64 : 27$. Calculate the ratio of their surface areas.
10. Radius of a solid sphere is 12 cm . How many spheres of radius 6 cm can be made by melting this sphere.
11. If the volume and surface area of a sphere are equal then calculate its radius.
12. A child converts a cone of height 24 cm and base radius 6 cm into a sphere. Calculate the radius of the sphere.
13. By melting down 3 spherical balls of radius 6 cm , 8 cm and 10 cm one big solid sphere is made. Calculate the radius of the new solid sphere.

Surface Area and Volume of a Combination of Solids Shapes

In our daily life we see many figures that are a combination of different shapes. For example, a capsule is a combination of a cylinder and 2 hemispheres stuck at the ends of the cylinder. Similarly, a spinning top has a hemispherical part and another that is cone shaped. Therefore, we have to think of methods to calculate the surface area and volume of these figures.



Figure - 35

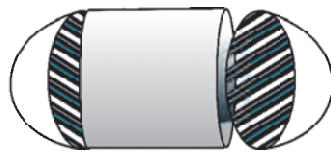

Figure - 36

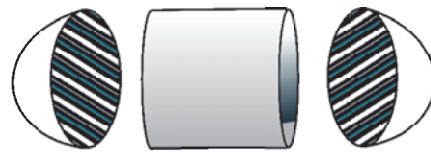

Figure - 37

Let us discuss the container which is shown in figure-35. We have to calculate the area and volume of an iron sheet needed to make this container but the container is not of a shape for which we already have some formula. If we have some solid figure which is similar to the one shown in figure 36, then what we do?

In such situations, we divide the figure into smaller parts so that we can calculate their area and volume easily and obtain the solution of the problem. We see that this capsule is made by joining the hemispheres at the ends of the solid cylinder. If we cut the container, then this figure will look as shown in figures – 36 and 37.

So to make the required container, the area of iron sheet needed = curved surface area of first hemisphere + curved surface area of cylinder + curved surface area of second hemisphere.

Volume of container = volume of first hemisphere + Volume of cylinder + Volume of second hemisphere.

Example-12. A vessel is in the form of a hollow hemisphere mounted by a hollow cylinder. The diameter of the hemisphere is 14 cm and total height of the vessel is 13 cm . Find the area of the iron sheet needed to make this container and volume of the vessel. (Thickness of iron sheet is negligible).

Solution : Diameter of hemisphere = 14 cm
 \therefore Radius of hemisphere = 7 cm
 Height of the cylindrical portion of vessel = $13 - 7$
 = 6 cm
 Curved Surface area of the cylindrical part = $2\pi rh$
 = $2 \times \frac{22}{7} \times 7 \times 6$
 = 264 cm^2
 Surface area of hemisphere = $2\pi r^2$
 = $2 \times \frac{22}{7} \times 7 \times 7$
 = 308 sq.cm

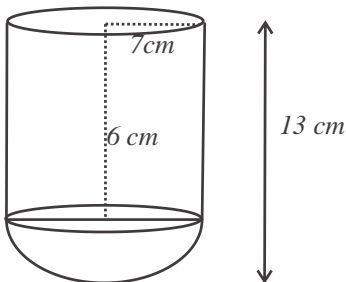

Figure - 38

Therefore, to make the container

Required area of sheet = Curved surface area of cylinder + Area of Hemisphere
 = $264\text{ sq.cm.} + 308\text{ sq.cm.}$
 = 572 sq.cm.

Volume of cylindrical part = $\pi r^2 h$
 = $\frac{22}{7} \times 7 \times 7 \times 6$
 = 924 cm^3

And, Volume of hemisphere = $\frac{2}{3} \pi r^3$



$$\begin{aligned}
 &= \frac{2}{3} \times \frac{22}{7} \times 7 \times 7 \times 7 \\
 &= 718.6 \text{ cm}^3
 \end{aligned}$$

Hence, capacity of vessel = Volume of cylinder + Volume of hemisphere

$$\begin{aligned}
 &= 924 \text{ cm}^3 + 718.6 \text{ cm}^3 \\
 &= 1642.6 \text{ cm}^3
 \end{aligned}$$



Exercise - 5

- In figure-39, the object is made of two solids - a cube and a hemisphere. The base of the figure is a cube with edges of 5 cm and the hemisphere fixed on the top has a diameter of 4.2 cm . Find the total surface area of the object (take $\pi = 22/7$).
- A toy has two parts. One part is cone shaped and has radius of 5 cm , and it is placed on the top of a hemisphere having similar radius. Total height of toy is 17 cm . Find the total surface area of the toy?
- A solid is in the shape of a cone standing on a hemisphere with both their radii being equal to 1 cm . The height of the cone is equal to its radius. Find the volume of the solid in terms of π .
- A spherical glass vessel has a cylindrical neck which is 4 cm long and 2 cm in diameter. The diameter of the spherical part is 6 cm . Find the amount of water it can hold?
- The upper portion of the greenhouse shown in figure-40 is semicircular. This greenhouse is made up of cloth. It has a wooden door of size $1.2 \text{ m} \times 0.5 \text{ m}$. Find the area of the cloth required to cover the green house completely.

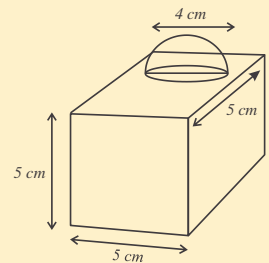

Figure - 39

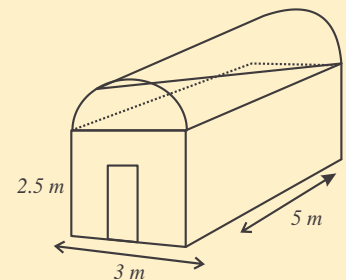

Figure - 40

What We Have Learnt

- We have learnt to make the net diagrams of 3-dimensional figures like cuboid, cylinder, cone etc. and to draw and understand the net diagram as well.
- To identify and understand the top, base, surface and edge of a cube and a cuboid.
- To identify and understand the different kinds of diagonals in cube and cuboid.
- Calculate the area and volume of a 3-D figure like cone, cylinder, sphere etc.
- To calculate the area and volume of objects which are a combination of different figures.



ANSWER KEY

Exercise - 1

1. $2\sqrt{21}$ m 2. 36 cm 3. 15 m

Exercise - 2

1. 880 cm.sq. and 2112 cm.sq 2. 42 cm 3. 2 cm 4. ₹68.75
 5. 1584 m² 6. 396 cm³ 7. 1540 cm³ 8. 6160 cm³
 9. 7 cm 10. 20 cm 11. 6.49 cm 12. 7700 cm³
 13. 2/3 14. 2.5 m 15. 35 16. 15 cm and 35 cm

Exercise - 3

1. 220 cm² 2. $6\sqrt{2}$ cm 3. 616 cm² 4. 5500 cm²
 5. ₹34320 6. 1500 cm³ 7. 21 cm 8. 77 cm³
 9. 1750 10. 12936 cm³ 11. 1 : 3

Exercise - 4

1. 5544 cm² 2. 196π cm² 3. 7 cm 4. 36π cm³
 5. 224π cm³ 6. 126 7. 1 : 4 8. 179.66 cm³ 9. 16 : 9
 10. 8 11. 3 unit 12. 6 cm 13. 12 cm³

Exercise - 5

1. 163.86 cm² 2. 115π cm² 3. ₹22000 4. π cm³
 5. 44π cm³ 6. 62.9 cm²

DATA ANALYSIS

CHAPTER

16

Introduction

Each day we come across different kinds of information. For example, this year production of rice increased by 8 percent; who was the best hockey player last year or, how many mobile phones were sold by company 'A' in the month of January? Similarly, from time to time we make use of printed information, for example, train timetables showing time of arrival and departure from stations, price of fruit-vegetables, current price of petrol, production amounts of grain and dairy, production of steel, coal etc. There are lots of other data which we use to plan for future and to take important decisions.

How to find different types of information

Can we tell today about the expected temperature of next two days? Or, the quantity of rice produced this year in our state? Or, what was the increase (or decrease) in price of petrol in the last five years?

It may not be possible to give the exact answer immediately but we can say something about these questions after analyzing relevant data.

We know that different types of data are published in newspapers and magazines, for example, data related to production of grains, weather-related information, details of games and sports, prices of food products etc.

Data related to health and education is collected by different departments and organizations under the government. In health, the government may have data on the areas most affected by a certain disease, the number of people suffering from a particular disease etc. On the basis of this information, we are able to decide the best measures to prevent the spread of a disease. Till about 6-7 decades ago, one of the most important questions for India was the quantity of grain produced every year, the quantity required to feed our population, and the quantity of grain that might have to be imported from other countries to meet our needs.

Try These

1. Besides mathematics, you must have come across data in other subjects like science, social studies etc. Give few examples of data in different subjects.
2. Look at some newspapers and magazines and collect examples of data printed in them. Discuss among yourselves the topics covered by these data.
3. Find which types of data are available in your school-office?
4. You might have seen data displayed on the notice board in your school premises. Which types of data you have seen?

Think and Discuss

Write the different sources from where you can get the answers of the following questions:

1. Which is the disease that most affects your district?
2. What is the population of your district in the current year?
3. In the current year, what is the minimum market rate of wheat and rice fixed by the government?

Some more questions

We also want to know the answers of many questions related to ourselves like, how fast can I run; can I run faster than my classmates? Am I taller (or shorter) than the other students in my class? How can we find the answer of questions like these? There may be a few students who run faster than you and a few who run slower; some will be taller and some shorter.

Rani's height is 160 cm. The height of her classmates, in cm, is shown in the table given below:

161	160	162	159	161	158	162	163
158	158	160	159	160	161	163	160
158	161	158	159	163	159	160	159
158	160	159	162	163	160	159	159
159	162	161	163	159	161	161	160
163	160	163	161	160	158	160	163
160	160						

From the given table, can you tell where does Rani stand as compared to her classmates? It will be difficult to compare her height with all students in her class. It will be easier to compare if we organise the given data. To organize our data, we will prepare a frequency table. Then our data will look as shown in table-1:

Table-1

Height (In <i>cm</i>)	158	159	160	161	162	163
Number of Students	7	10	13	8	4	8

What you interpret or conclude by looking at this table?

First thing that we can conclude is that maximum students are in the 160 *cm* group. This group contains 13 children. 17 children are in those groups whose height is less than Rani's height. Minimum height is 158 *cm* and there are 7 children in this group.

What else can we conclude from this table? Discuss with your friends and find at least 5 more conclusions.

In the same way if we talked who runs the fastest, then we find that the speed of all runners is not same. The table below shows the speed of 50 persons in km per hour i.e. it describes the number of kilometer covered by each runner in one hour.

Table-2

Speed of running (km per hour)	15	11	9	5	6	4
Number of students	5	6	7	8	9	10

This means that if Nafisa can run at 7 km/h then we can do a comparative analysis of her speed with the help of the given table. We can also see that how many persons run faster than her and how many students run slower than her.

Try These

Read the questions given below. What kind of data do we need to find the answer of these questions? Discuss and write from where and how we will get these data?

1. How did the price of petrol vary during the last three years?
2. Which state in our country had minimum rainfall this year?
3. In what quantity production of fish increased in the last five years?
4. Population of which state was maximum in 2011?
5. What changes happen in last five years in your village and city?
6. Which district of Chhattisgarh has the maximum number of schools?
7. How many international hockey matches were played by India in the last five years?
8. How much rice was produced all over India from 2010 to 2015?

Think and discuss

1. If the number of students in your school is 1000 and you want to compare your height with all of them, how will you do it?
2. What kind of data will you need if you want to compare your running speed with all the students in your district?

Graphical Representation of Data

You learnt organisation and representation of data in your previous class. You studied about frequency tables and graphical representation of data, in which we tried to learn how to make histograms, frequency polygons and cumulative frequency curves. We get many types of information and can draw several conclusions on the basis of these data representation. Let us consider more examples of these types of data in the following section.

Bar Graphs

The bar graph given below shows the production of wheat in a state in different years-

Which information can be seen clearly on considering this graph? Find out the answers of the following questions by reading the graph.

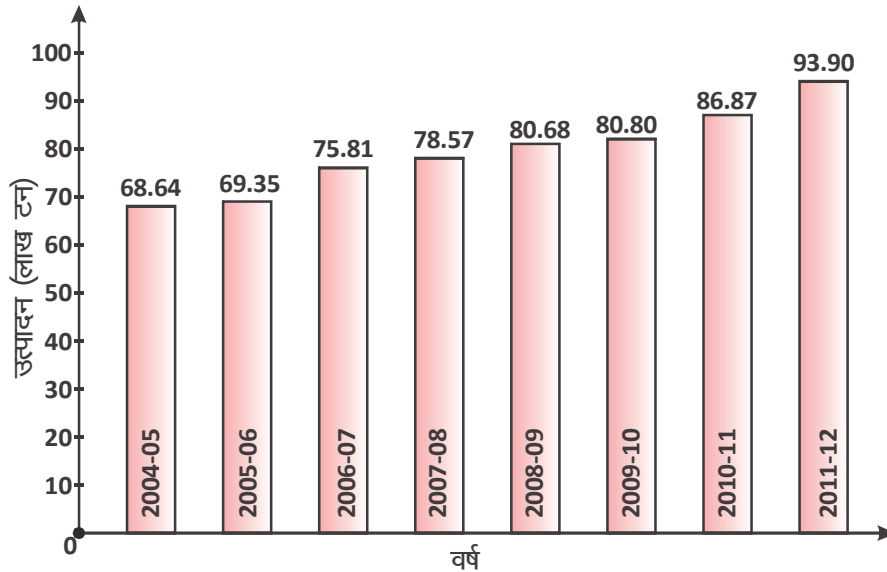

- How many tons of wheat was produced in 2007-08?
- In which year was the production of wheat maximum?
- Can we say that the production of wheat increased every year?
- The production of wheat showed greatest change in which two years?

Try These

Reading a table

The table given below shows the amount of annual rainfall in a particular city.

Year	1980	1981	1982	1983	1984	1985	1986	1987	1988	1989
Total Rainfall	24-7	21-2	14-5	13-2	12-1	16-8	19-9	29-2	31-6	21-0

(in inches)

Study these figures related to rainfall, draw their bar graph and find at least five conclusions based on the graph.

Mean, Median, Mode

You found the answer to some questions and drew conclusions from bar graphs and frequency curves. Can you tell that what was the average annual production of wheat during 2005 to 2015 by looking at the bar graph? Can you tell which year will fall in the middle if we arrange the data in order? From the second table we can find the average rainfall in a city in a year or generally how much annual rainfall is expected. We cannot say anything about the order and trend of data only by looking at bar graphs. To find average wheat production we need arithmetic mean. Recall, how we can calculate mean.

Arithmetic Mean

Now, to find average production of wheat from the year 2005 to 2012 we add the wheat production (in lacs ton) of these years then divide it by the number of years. Let us see what is the average value of annual wheat production.

$$\begin{aligned} \text{Total production} &= 68.64 + 69.35 + 75.81 + 78.57 + 80.80 + 80.80 + 86.87 + 93.90 \\ &= 634.74 \text{ lacs ton} \end{aligned}$$

Number of years from 2005 to 2012 = 8 years

$$\begin{aligned} \text{Average production} &= \frac{634.74}{8} \\ &= 79.34 \text{ lacs ton} \end{aligned}$$

Here, we calculated the average value of wheat production. In statistics, average of data is known as arithmetic mean. So if we want to find arithmetic mean then we add the data and divide the sum by the number of data points. The following formula is used to show this relation:

$$\text{Arithmetic Mean} = \frac{\text{Sum of data}}{\text{Total number of data}}$$

If data is written as x , then sum of data is Σx and number of data is n . Then

$$\text{Arithmetic mean} = \frac{\Sigma x}{n}$$

Arithmetic mean is generally denoted by A.M., M and \bar{X} .

Discrete Series

Data considered till now was individual points in a series and the number of data-points was small. If the number of data-points is larger then how can we calculate arithmetic mean?

Marks obtained in mathematics by 35 students from Class-IX are as follows:

30, 30, 38, 40, 42, 35, 40, 30, 45, 48,
 40, 42, 38, 30, 38, 40, 35, 30, 42, 40,
 42, 38, 35, 42, 40, 38, 42, 40, 48, 45,
 38, 40, 30, 35, 35

Here, minimum marks obtained is 30 and maximum is 48. It is seen that the marks are limited to 35, 35, 38, 40, 42, 45, 48 and they are repeated again and again. Therefore, these figures can be written in the following way:

Marks Obtained (x) : 30 35 38 40 42 45 48
Frequency (f) : 6 5 6 8 6 2 2

When we have this type of data then for calculating arithmetic mean we multiply the data-points (observations) with their corresponding frequency and add them. This sum is divided by the sum of frequencies to get arithmetic means.

Marks obtained (x)	Frequency(f)	Product of marks obtained and their corresponding frequencies
30	6	180
35	5	175
38	6	228
40	8	320
42	6	252
45	2	90
48	2	96
	$\sum f = 35$	$\sum fx = 1341$

\therefore Arithmetic Mean =

$\frac{\text{Sum of the product of marks obtained and corresponding frequency}}{\text{Sum of frequencies.}}$

$$\bar{X} = \frac{f_1x_1 + f_2x_2 + f_3x_3 + f_4x_4 + f_5x_5 + f_6x_6 + f_7x_7}{f_1 + f_2 + f_3 + f_4 + f_5 + f_6 + f_7}$$

$$= \frac{\sum f_i x_i}{\sum f_i}$$

$$= \frac{1341}{35}$$

$$\bar{X} = 38.31$$

Average marks in mathematics of Class-IX student is 38.31.

Now we will discuss about arithmetic mean of data where observation points are repeated and also the number of observation points is very large. In this case, we distribute the data into groups to calculate arithmetic mean.

Let us consider an example.

Example-1: There are 100 students in the village middle school. The distance in *km* between their houses and school is given below. Find the average distance between home and school using this data.

17	1	19	0	4	1	3	2	0	4
5	7	2	8	9	19	2	17	1	18
0	3	2	5	2	8	1	10	1	11
13	8	9	4	15	0	15	3	11	11
2	19	0	14	12	1	12	1	13	1
9	3	6	4	14	3	10	12	4	8
0	7	9	6	5	9	7	8	2	9
5	8	6	7	9	5	5	6	3	8
7	5	0	1	3	0	4	2	0	1
3	0	4	3	2	0	1	0	4	0

Solution: If we look at the data, we find that many observations are repeated and the minimum value is 0 and the maximum value is 19. We will have to divide the data into group, so that calculations become easy.

Let us divide the data into groups at equal intervals, 4 in this case. We find that number of students whose homes are at distance between 0-4 *km* is 39, number of students who comes from 4 to 8 *km* is 24 and so on. Find the number of students in the group 8-12 *km*, 12-16, and 16-20.

Distance of school from the home of student (<i>km</i>)	Number of students (<i>f</i>)	Midpoint (<i>x</i>)	<i>f</i> <i>x</i>
0-4	42	2	84
4-8	24	6	144
8-12	19	10	190
12-16	9	14	126
16-20	6	18	108
	$\sum f_i = 100$		$\sum f_i x_i = 652$

In the table above, we calculated the midpoint of each interval by adding the upper and lower limits of each interval and dividing by 2. Now we add the product of midpoint and number of students to get the average.

$$\begin{aligned}
 \text{Average} &= \frac{\text{Sum of products of number of students and midpoint}}{\text{Total Number of students}} \\
 &= \frac{84 + 144 + 190 + 126 + 108}{100} \\
 &= \frac{652}{100} \\
 &= 6.52 \text{ km}
 \end{aligned}$$

We can consider average as a number that represents a single feature of the entire group of observations. Obviously, average is greater than the minimum data value and smaller than the maximum value and it lies somewhere in the middle of the whole data. This is 'arithmetic mean'.

Calculation of arithmetic mean

Let us consider some more examples to understand arithmetic mean.

Data related to production of pulses in five years is given in the table below:

Years	2007–08	2008–09	2009–10	2010–11	2011–12
Production of pulses (in lacs ton)	14.8	14.6	14.7	18.2	17.2

Here, we have to find the arithmetic mean or average. To find this we have to add all observation points and after that divide the sum by the total number of years.

$$\begin{aligned}
 \text{Arithmetic mean} &= \frac{14.8 + 14.6 + 14.7 + 18.2 + 17.2}{5} \text{ lac tons} \\
 &= \frac{79.5}{5} = 15.9 \text{ lac tons}
 \end{aligned}$$

Average production of pulses is 15.9 lac tons. Actual value of pulses produced in each year is different from the average annual production. By using average, we can give one value to show the production of pulses of five years.

Let us consider one more example of average.

Example-2: The data for rainfall (in mm) in Dhamtari district are given. Find the average of this data.

880.5, 1474.9, 806.3, 1554.9, 1019.2, 1046.5, 1017.2

Solution : You know that

$$\text{Mean} = \frac{\text{Sum of observation} - \text{points}}{\text{Number of observation} - \text{points}}$$

$$\begin{aligned} \text{So, average} &= \frac{880.5 + 1474.9 + 806.9 + 1554.9 + 1019.2 + 1046.5 + 1017.2}{7} \\ &= \frac{7799.5}{7} = 1114.21 \text{ mm} \end{aligned}$$

So, arithmetic mean of rainfall is 1114.21 mm

Uses of Average in day-to-day life

Can you tell how much time do girls generally get to play at home? We know that daily playing time is not fixed; some days one can play for many hours and on some days we may get only a few hours or no time at all to play.

This means that if we only observe one girl for one day then we can't say how many hours are spent on play by all girls. If you collect the data of playing time over several days for several girls then you will have large quantities of data. It will not be easy to organise this data. To solve the given problem, we can consider the data over one month and find average daily playing time. Consider table-3. Here we are given the time spent playing of 50 girls. Can you tell how much time is spent per day by most girls on sports and games?

In table-3 you can see that on average, most girls get less than 2 hours to play. The maximum number of girls, 12, on an average play for at least 2 hours per day but the average daily playing time is not 2 hours for all the girls. To find the arithmetic mean in the given case, we first need to know the average daily playing time of all 50 girls individually.

Table-3

Average daily play time (in	Number of girls	Total play time for 50 girls hours)
x_i	f_i	$x_i f_i$
0	4	0
$\frac{1}{2}$	6	3
1	8	8
$1\frac{1}{2}$	9	$13\frac{1}{2}$
2	12	24
$2\frac{1}{2}$	7	$17\frac{1}{2}$
3	4	12
कुल	$\sum f_i = 50$	$\sum f_i x_i = 75$

$$\text{Average} = \frac{\sum f_i x_i}{\sum f_i}$$

$$\text{Average} = \frac{75}{50} \text{ hours}$$

$$= 1 \text{ hour } 50 \text{ minutes.}$$

If the frequency of observations $x_1, x_2, x_3, \dots, x_n$ are $f_1, f_2, f_3, \dots, f_n$, respectively then it means that observation x_1 occurs f_1 times, data x_2 comes f_2 time and so on.

For example, in this problem the number of girls who on an average play for 0 hours is 4 and the number of girls who on an average play $\frac{1}{2}$ hours is 6 and thus $x_1 = 0$, $f_1 = 4$ and $x_2 = \frac{1}{2}$, $f_2 = 6$

Now, sum of products of observations and their respective frequency

$$\Sigma(xf_i) = f_1x_1 + f_2x_2 + f_3x_3 + \dots + f_nx_n \text{ and}$$

$$\text{Total number of observations} = f_1 + f_2 + \dots + f_n$$

To find the mean we will divide the sum of products by the sum of frequencies. In this way, the mean is:

$$\text{Mean (Arithmetic mean)} = \frac{\sum f_i x_i}{\sum f_i} \text{ where the value of } i \text{ will from 1 to } n$$

Sum is represented by the Greek letter “ Σ ”, called sigma. This represents sum therefore sum of frequency is represented by “ f_i ” and sum of products of observations and frequency is represented by “ $x_i f_i$ ”.

It means that on an average every girl gets 1 hour 50 minutes to play each day. Now let compare this average with the rest of the data.

Can you tell how many girls play more than the average time and how many girls play less than the average time? You can see that 27 girls play more than the average time and 23 girls play less than the average time.

We find that, similar to this example, when we need to study data on a large scale then averages help us to organise the data; like in the examples of average play-time of girls or the average running speed of different persons.

Try These

1. Use the data given in previous example to find the average height of a student in a class of 50. Compare this height with your own height.
2. Use the data of 50 students given in table-2 to find the average speed. What conclusions we can draw from it?

In the previous example, you learnt how to find the average of given observations but suppose you are given the average then can you find the unknown observations?

Let consider the example given below:-

Example-3. Average of following observations - 25, 39, 35, f , 46 - is 36. Find the unknown data point, f .

Solution: You know that

$$\text{Average} = \frac{25 + 39 + 35 + f + 46}{5}$$

$$\text{Average} = \frac{145 + f}{5}$$

On putting value of average in the equation

$$36 = \frac{145 + f}{5}$$

$$36 \times 5 = 145 + f$$

$$180 = 145 + f$$

$$180 - 145 = f$$

$$35 = f$$

Therefore, value of f is 35. Thus the data points are 25, 39, 35, 35, 46.

Example-4. Find out the average height of students with the help of data given in the table.

Height (in cm)	158	159	160	161	162	163
Number of students	7	10	13	8	4	5

Solution : We know that mean (Arithmetic mean)

Height (in <i>cm</i>) (x_i)	Number of students (f_i)	($f_i x_i$)
158	7	1106
159	10	1590
160	13	2080
161	8	1288
162	4	648
163	5	815
	$\sum f_i = 47$	$\sum f_i x_i = 7527$

$$\begin{aligned} \text{So arithmetic mean} &= \frac{7527}{47} \\ &= 160.15 \text{ cm} \end{aligned}$$

So average height of student is 160.15 *cm*

Try These

- Find the average of first 15 natural numbers.
- Price of petrol (in Rupees) in Bhubaneswar (Orissa) during March-April, 2010 is given below. Find the mean of the data.
61.28, 62.08, 59.35, 56.28, 59.28
- Data (in lac tons) regarding rice production of a state over an 8 year period is given. Find the average of given data.
84.98, 93.34, 71.82, 88.53, 83.13, 91.79, 93.36, 96.69

What Averages Tell Us

We saw that average gives us some basic information that represents a property of the entire data. But does arithmetic mean give us the complete picture of the whole data?

Read the following statements:-

- This year, the average day-time temperature was 23°C in the month of February.
- Average cost of petrol over the last five years was Rs. 65.70.
- Average age of Class-X students is about 15 years.

You must have read or heard many more statements of this type. When we hear about average temperature of a day or month; or average price of petrol then we get some general idea and can draw some conclusions. But there are several pieces of information which we can't find from average.

For example, in Statement-1, in the month of February, the temperature would have been more than 23°C some times and other times less than 23°C. Average does not tell what the temperature was on a particular day; or what was the maximum temperature during the month or what was the minimum temperature; was there a lot of variation in day-to-day temperature or was it more or less constant?

In Statement-2 too, petrol prices must have varied from time to time. Average price of petrol could not have been 65.70 each year. From average, we can't say anything about the price of petrol today? But still, if we know that the price of petrol does not fluctuate daily or frequently then from average we are able to estimate that price of petrol per liter would have probably varied from about Rs. 64 to Rs. 66.

From statement-3, we know that age of some students will be less than 15 years and more than 15 years for others; we can't get any more information from this statement.

Let us consider one more example of average:

Example-5: The salaries of seven workers are given below:

1400 1500 8400 8700 9000 9200 9400

Let us calculate the average salary.

$$\begin{aligned} \text{You know that, Average} &= \frac{1400 + 1500 + 8400 + 8700 + 9000 + 9200 + 9400}{7} \\ &= \frac{47600}{7} = 6800 \text{ Rupees} \end{aligned}$$

Average salary as per data is Rs. 6800.

But, is average able to appropriately represent the center of the data? None of the seven data-points is approaching or close to the average. From this average, we can find out how money is spent each month on paying salaries but can't say how much a particular employee gets.

We conclude that average is not helpful in understanding distribution of data.

Median

When the values of data-points are very different from each other, then we are not able to draw many important conclusions from mean. In such cases, we will use a new numerical representative called median. Median is the data-point that comes exactly in the middle of organised data.

Let try to understand median with an example and then consider its utility.

Consider salary data given in Example-5 -

1400, 1500, 8400, 8700, 9000, 9200, 9400

What is the median of this data? There are 7 terms in data series which means that the fourth term is the middle term. Therefore median of this data is 8700. Middle term of the data given us median; sometimes, median is better able to represent data in appropriate manner because median value is not affected by extreme values in the data.

Try This

Find the median of the following data:

1. 25, 21, 23, 18, 20, 23, 24
2. 113, 102, 95, 85, 110, 109, 106, 110, 115

Let understand some more important uses of median.

Example-6. 21 people appear for interview for 10 posts in an office. They get following marks out of 50 in the interview:-

25, 23, 45, 40, 42, 38, 32, 43, 47, 36, 28, 37, 35, 34, 42, 21, 27, 18, 39, 41, 40

How will we select the 10 persons for the job? What should we do?

We know that those 10 will be selected from 21 people who get maximum marks. To make this process easy we arrange data in ascending order which will as follows:-

18, 21, 23, 25, 27, 28, 32, 34, 35, 36, 37, 38, 39, 40, 40, 41, 42, 42, 43, 45, 47

In this data, the 11th term i.e. 37 is median which lies between 10 people from the beginning and 10 people from the end. So, for job those who get more than 37 marks will be selected where 37 is median of data.

Thus, if total number of data is n

Then, median of data will be $\left(\frac{n+1}{2}\right)^{th}$ term.

You can see that in examples 4 and 5, the total number of data-points is odd. If the number of data-points is odd we can use the above formula to easily find the median.

But, if the total number of data-points is even then how can we get median? Let us try to understand this by an example.

Example-7. Height (in *cm*) of 10 students are following:-

117, 106, 123, 110, 125, 112, 115, 102, 100, 115

Find the median of this data.

Solution: To find the median, first arrange the data-points in ascending order

100, 102, 106, 110, 112, 115, 115, 117, 123, 125

Here, since the number of data-points is even therefore neither the fifth term nor the sixth term is right in the middle. The middle term of data i.e. the median will lie between fifth and sixth terms. So, the median of data in this situation is the average of the two middle terms. In this example-

Fifth term = 112 *cm*

Sixth term = 115 *cm*

$$\text{Median} = \frac{\text{Fifth term} + \text{Sixth term}}{2}$$

$$= \frac{112+115}{2} = 113.5 \text{ cm}$$

Median of this data is 113.5 *cm*

This means that when number of data-points is even then we can understand median as follows:

$$\text{Median} = \frac{\left(\frac{n}{2}\right)^{\text{th}} \text{ term} + \left(\frac{n}{2} + 1\right)^{\text{th}} \text{ term}}{2}$$

So far we have calculated median of given observations. Now we will use median to find missing observations.

Example-8. Median of the data series 7, 10, 12, *p*, *q*, 27, 31 arranged in ascending order is 17. If one more data-point 40 is included then median becomes 18. Find the value of *p* and *q*.

Solution : You know that median is always the middle term of a data series.

In the series 7, 10, 12, *p*, *q*, 27, 31 the fourth term lies in the middle and its value will be the median. We are given that the median is 17 and since the fourth term is *p*, so *p* = 17.

If one more observation 40 is included in the series then we get 7, 10, 12, *p*, *q*, 27, 31, 40. Now number of data-points becomes even so

$$\text{New Median} = \frac{\left(\frac{n}{2}\right)^{\text{th}} \text{ term} + \left(\frac{n}{2} + 1\right)^{\text{th}} \text{ term}}{2}$$

$$18 = \frac{p + q}{2}$$

$$18 = \frac{17 + q}{2}$$

$$36 = 17 + q$$

$$19 = q$$

So, the values of p and q are 17 and 19 respectively.

Mode

You read about average and median. One more method of to derive conclusions from any data is finding its 'mode'. Mode is the data point that occurs the maximum number of times in a series. For example, in a Class-X examination, marks obtained by 20 students are:-

40, 25, 40, 35, 36, 45, 45, 40, 35, 39, 41, 42, 40, 25, 40, 42, 35, 38, 40

After looking at the data we find that maximum number of students (6) got 40 marks so mode is 40. Let consider one more example:

Example-9. A shopkeeper sells shoes of different sizes (6, 7, 8, 9, 10) in his shop. Sales data in three months is as follows

Shoe size	6	7	8	9	10
Number of shoes sold	18	24	41	19	9

The shopkeeper saw that many shoes had been sold in three months. Now shopkeeper wanted to restock his shoes. Can he use mean and median to decide which shoe-size should be ordered from the shoe-company at the earliest to complete his stock? He can't find this from mean and median. He has to reorder the shoes in the size that is sold more frequently.

On considering above records, the shopkeeper decided to order shoes in size 8. For the time being, he decides not to buy shoes in other sizes. You can see that the maximum demand of shoes is in size 8 from the number of shoes sold.

Therefore, here mode is 8.

Try These

Find the mode of the following data:-

1. 25, 9, 69, 34, 70, 36, 90, 70, 56, 70, 71
2. 56, 39, 94, 36, 39, 15, 39, 40

Exercise - 1

1. To find the answers to the following questions will you use arithmetic mean or median? In which question(s), we can't use either of the two?
 - (i) Which is the most popular newspaper in the state?
 - (ii) What was the average rainfall in a month?
 - (iii) 100 students participated in an examination. Who are the top-performing 50 students among them depending on marks obtained?
 - (iv) What was the average price of petrol in the month of January?
 - (v) Which player has taken highest number of wickets in international cricket matches?
 - (vi) How will you decide the number of rotis to be cooked for 20 guests invited to a party?
 - (vii) In which month does maximum rainfall occur?

2. Data of rainfall (*mm*) in 10 months is as follows:-

243.50, 266.00, 347.70, 240.00, 325.20,
264.80, 356.30, 211.60, 246.90, 282.70

Find the average rainfall from the data.

3. Name the first 10 even numbers. Find their average.
4. Find the average price of rice in five different states from the given data-

City	A	B	C	D	E
Price (In Rupees)	25	28	30	31	32

5. The table below gives data for high jump in international games (Olympics). Find the mean, mode and median of the data.

Year	1960	1964	1968	1972	1976	1980	1984	1988	1992	1996	2000	2004
Height (in meter)	1.85	1.90	1.82	1.92	1.93	1.97	2.02	2.03	2.02	2.05	2.01	2.06

6. Weight (in kilograms) of eight students is as follows-
- 30, 32, 33, 38, 37, 41, 35, 40
- Find the average weight of the students.
7. Number of students enrolled in a school over five consecutive years is as follows-
- 1150, 1250, 1360, 1275, 1310
- What was the average number of students in the school in this five-year period?

Limitations of Arithmetic Mean, Median and Mode

To interpret data one representative value is the arithmetic mean. We saw that mean gives us a lot of information about the data, but many aspects remain unclear and mistakes can happen if we use mean blindly in all situations. For example, we cannot decide the height of doors in a house by taking the average height of all family members. Nor can we decide it by finding out the most common height of the family members.

Besides the limitations of using mean, we saw that median and mode are also unable to give answers to all our questions. These are helpful in understanding data but we should use these very carefully.

Measures of Central Tendency in Grouped Data

In most cases the number of observations is so large that to interpret and read it correctly we first have to reduce its complexity by making groups (by classifying it). After converting it into group data we can find mean, median and mode to interpret it.

In example-13, grouped data is given by taking class interval of 10. It should be remembered that while determining frequency of class interval, any data which is equal to upper limit of a class interval will be placed in the next class interval. For example, the year in which production of rice was 50 lacs ton is not placed in the interval 40-50 but in the class interval 50-60.

We saw that to calculate the mean of ungrouped data, we first sum all data-points. But what we will do for grouped data? Which value should we take from a group, which number should we choose? For class interval 40-50, should we take 40 or 50 or any other value?

So, we need values which will represent the different groups. We assume that frequencies of all class intervals are centred around the mid-point and mid-point of each class interval is representative of that class interval. We can also call these mid-points class marks.

Example-10. Data of weight of young and old groups of children of a senior secondary school is given below. Find the average weight per child.

Weight (In kg)	30–40	40–50	50–60	60–70	70–80
Number of students	11	29	6	3	1

Solution: First we find mid-point. To find mid-point we have to use class-limit. Mid-point is the average of upper limit and lower limit of class. Mid-point of the class (30-40) is 35, i.e.

$$\text{Mid-point} = \frac{\text{Lower Limit} + \text{Upper Limit}}{2} = \frac{30 + 40}{2} = 35$$

We denote mid-point by x_i . First mid-point x_1 is 35.

In the same manner we can also find mid-points of other classes and they are 45, 55, 65 and 75 respectively. Now, we multiply each mid-point with corresponding frequency and use it to calculate mean. The new table will be as follows:

Weight (kg)	Number of students (f_i)	Mid-point (x_i)	($f_i x_i$)
30–40	11	35	385
40–50	29	45	1305
50–60	6	55
60–70	3	65
70–80	1	75
योग	50		2290

Complete the table.

So, we find that the sum of $f_i x_i$ in the above table i.e. $\sum f_i x_i = 2290$.

So, the mean \bar{X} of the given data will be:

$$\bar{X} = \frac{\sum f_i x_i}{\sum f_i} = \frac{2290}{50} = 45.8 \text{ kg}$$

Thus, average weight per child is 45.8 kg.

Mode of Grouped Data

In the example given above, we found weight of children on an average. If we want to know how much most children weigh then we will have to find the mode.

You know that mode is that data value which is seen most frequently. In grouped data, we first find the group containing the mode. In given data, the frequency of class (40-50) is greatest so it is the mode class. This means that mode is present in this class interval. In such situations, we can find mode by putting the values in the following formula.

The more the difference between f_1 and f_0 greater is the mode than l . Similarly, lesser the difference between f_1 and f_2 , more is the distance between l and mode and closer is mode to $l+h$. If we think about what can be the maximum value of mode we will find that the maximum value can be the sum of l and h , which is the difference between f_2 and f_1 or between f_1 and f_0 . That is, the mode will lie between l and $l+h$.

The formula for finding mode is

$$\text{Mode} = l + \left[\frac{f_1 - f_0}{2f_1 - f_0 - f_2} \right] \times h$$

इस सूत्र में—

l = lower limit of mode class

f_0 = frequency of the class preceding the modal class.

f_1 = frequency of the modal class.

f_2 = frequency of the class succeeding the modal class.

h = size of the class interval.

Example-11. In the table of example 10, the modal class = 40–50, the lower limit of modal class (l) = 40

frequency of the modal class (f_1) = 29

frequency of the class immediately preceding the modal class (f_0) = 11

frequency of the class immediately succeeding the modal class (f_2) = 6

Size of the class interval (h) = 10

By putting these values in the formula

$$\begin{aligned} \text{Mode} &= 40 + \left[\frac{29-11}{2(29)-11-6} \right] \times 10 \\ &= 40 + \left[\frac{18}{58-17} \right] \times 10 = 40 + \frac{18}{41} \times 10 \\ &= 44.39 \text{ kg} \end{aligned}$$

This mode is near to $l+d$ because f_0 is big and f_2 is small.

In this way we can find mode of grouped data which is close to observations.

Median of Grouped Data

Example-12. Height of girls in X class of a school is as follow:-

Height (cm)	135–140	140–145	145–150	150–155	155–160
Number of Girls	1	2	11	9	7

Find the median of these data.

Solution: To find the median from given data we have to find cumulative frequency from frequency (you have learnt how to find cumulative frequency in class IX).

Height	Number of girls (Cumulative frequency)
less than 140	1
less than 145	$1 + 2 = 3$
less than 150	$3 + 11 = 14$
less than 155	$14 + 9 = 23$
less than 160	$23 + 7 = 30$

This cumulative frequency distribution is of the type 'less than' where 140, 145, 150, 155, 160 are the upper limits of the class.

We know that the mid-point observation of the given data will lie in some class interval. How do we find that class interval in which middle data point is present?

Height	Number of girls (f)	Cumulative frequency (cf)
135–140	1	1
140–145	2	3
145–150	11	14
150–155	9	23
155–160	7	30

To find median class we find cumulative frequency of each class and $\frac{n}{2}$. Now we find that class whose cumulative frequency is greater than or very near $\frac{n}{2}$. Here, this is $n = 30$ i.e. $\frac{n}{2} = 15$. Since, 150-155 is that class whose cumulative frequency, 23 is more than 15 therefore median class will be 150-155.

Thus, median class is 150-155. After finding median class we can find median by using the following formula-

$$\text{Median} = l + \left(\frac{\frac{n}{2} - cf}{f} \right) \times h$$

Where, l = lower limit of median class

n = number of observation

cf = cumulative frequency of class preceding the median class

f = frequency of median class

h = class size (assuming class sizes to be equal)

Now, $\frac{n}{2} = 15$, $l = 150$, $cf = 14$, $f = 9$, $h = 9$

$$\begin{aligned} \text{Median} &= 150 + \left(\frac{15 - 14}{9} \right) \times 5 \\ &= 150 + \frac{5}{9} \\ &= 150.55 \text{ cm} \end{aligned}$$

So, the height of about half of the girls is less than 150.55cm and the height of remaining half is more than or equal to 150.55cm .

In the same way we can also arrange data in the form of 'more than'. This is shown in the table. We can interpret many things from this table, for example, the height of 16 girls is more than 150cm etc.

Height	Number of girls
More than or equal to 135	30
More than or equal to 140	29
More than or equal to 145	27
More than or equal to 150	16
More than or equal to 155	7

What conclusion can you draw from this table? Discuss and find 3 conclusions.

Data Trends: Extrapolation and interpolation

We find that after organizing and interpreting data we get many types of information but not all. One more question that can be asked is whether we can say something about data beyond the data given in each class interval? Imagine that we have kept records of total rainfall in a city for certain number of years. But the data of rainfall of some years could not be collected and hence, is missing. So, can we figure out what these missing data are? Also, can we predict how much it will rain in the coming years on the basis of this data?

To answer these two questions, we consider the pattern shown by the data. Is there a pattern to the change of data? Can we see certain trends in the data? We will look at the few examples to understand this better and to also see where we can apply extrapolation and where we can't?

Suppose you heat a liquid for 40 minutes and record its temperature at four different times as shown in the table:-

Time (in minutes)	0	10	30	40
Temperature (in degree Celsius)	20	30	50	60

If we represent this data on graph we get some points. Draw a curve that joins all the points. We can say that in the beginning temperature was 20°C at 0 minute, 30°C after 10 minutes, 50°C after 30 minutes, and 60°C after 40 minutes but can we say something about the temperature after 20 minutes or 60 minutes by looking only at the data. Obviously not! Temperature is given only on minutes 0, 10, 30 and 40. 20 minutes come in the 10-30 interval. With the help of the graph we can determine the corresponding temperature at 20 minutes and that is 40°C (Graph-2).

Here, in the given data there are infinite points which lie within the given data range for which we can find the corresponding temperature on the graph. This is known as interpolation.

Notice that here range of data is between 0-40 (minutes). The time point 50 minutes falls after this range. To know the

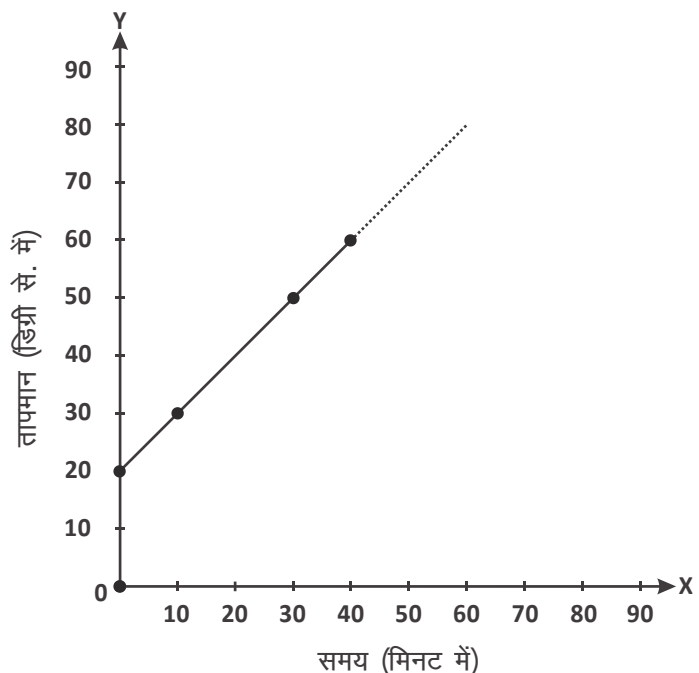

temperature at 50 minutes we will extend the graph lines in its direction. On extending the line we get the temperature 70°C at 50 minutes. Other corresponding temperatures can also be shown on extending the line in the same manner. This method in which we can find values beyond the data range by following the known trend is known as extrapolation. It is assumed that trend in change of data is uniform and there is no any unacceptable fluctuation in data within and beyond the range of data.

Limitations of Interpolation and extrapolation

In the above example, on the basis of graph we were able to find the temperature at 20 minutes which is between the data range 0 to 40 and on 50 minutes which was outside the range. Can you tell about temperature of liquid when it is boiled for 90 minutes? From the graph, we can see that temperature of the liquid increases by 10°C every ten minutes and on extrapolation the temperature will be 110°C at 90 minutes. Is it possible for water being boiled in an open vessel to reach this temperature? It is obvious that the trend of this graph will change slowly after some time and we can't extrapolate in an unlimited manner in this data.

Second question is whether we can do interpolation and extrapolation with any kind of data. Can we do interpolation and extrapolation in the following data? Let us consider-

Data of maximum high jump in Olympics is as follows-

Year	1960	1964	1972	1976	1980
Height (in meter)	1-85	1-90	1-92	1-93	1-97

On the basis of this data can you tell us what the record for high jump was in the year 1956?

It is not possible because there is no any trend in this data. This is data of the height of jumps which is recorded during the competition. In the same way if there is no trend in the population data, then we can't predict population for the following years or what the population was between the given years. It means there are limitations to interpolation and extrapolation of data due to trends of data and we cannot carry out interpolation and extrapolation on all types of data.

Think and Discuss

Result of Class-X exams are given in the table below:-

Years	2001	2002	2003	2005
Result	88%	80.5%	66%	55%

Can you figure out the results in the years 2004 and 2006?

Getting Data from Graphs

Try These

Collect height (cm) and age data of 40 boys and girls in different classes in your school and draw the graph between their ages and age-wise average height (be careful while taking data that each age group contains at least 3 to 5 children).

Answer the following on the basis of your graph-

1. Average height of 15 year old girls?
2. Average height of 10 year old girls?
3. What is the increase in the average height of the girls from the age of 13 years to 15 years?
4. Can you find the average height of 14 year old girls? How?
5. What is the average height of 16 years old girls?

How can we find the answers of questions 4 and 5?

Hint: Show 14 years on the X-axis. Draw a perpendicular from this point on the X-axis to a point on the graph. Draw a straight line from this point on the graph to the Y axis. The value on the y-axis where the line meets it will show the average height of 14 year old girls. The same method can be used to estimate the average height of girls or children of any age group from the graph.

6. Can you use the same graph to estimate the average height of 6 year old girls or 20 year old girls? Discuss and write your answer.

Example-13. Consider the following graph which is related to population and give the answers of the questions on the basis of this graph.

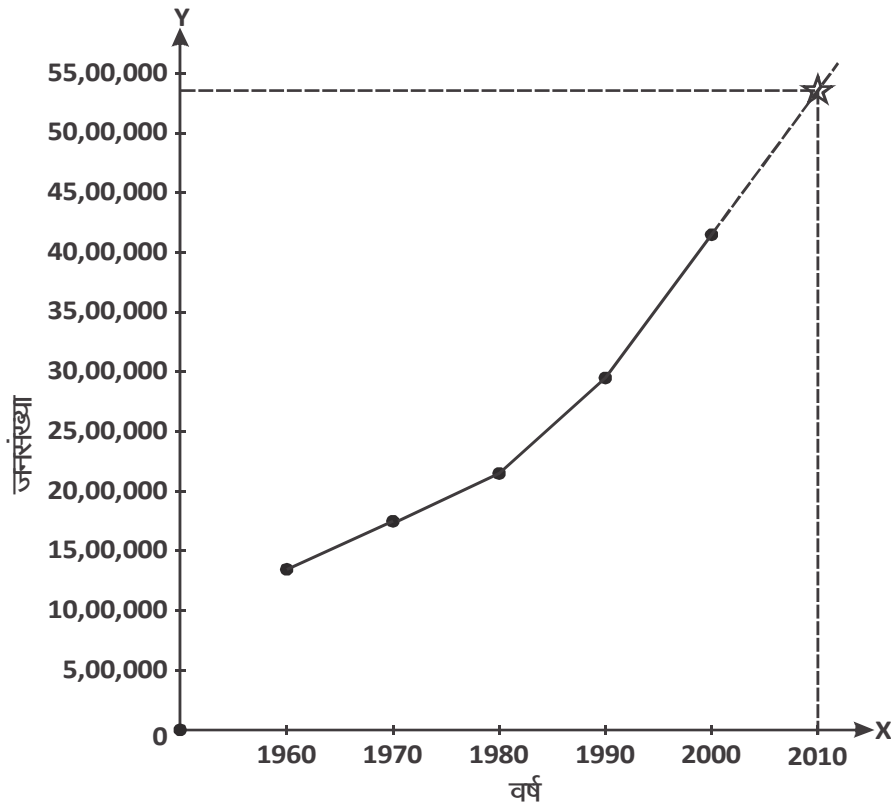

- What was the population in the year 1980?
- What is the growth in population from 1960 to 2000?
- What was the population in the year 1975?
- What was the population in the year 1995? Find out.
- Does on the basis of given data, can we estimate the population in the year 2010?

We can get the answers of questions (i) and (ii) directly from the graph. But the data related to questions (iii), (iv) and (v) will have to be extracted from the graph. If we consider the data in the graph it is continuously increasing. Besides showing years 1975, 1995 and 2010 on X-axis, we will also have to extend the scale from 4,500,000 to 5,500,000 on the Y-axis. Now if we join the points corresponding to years 1975, 1995 and 2010 on the graph to corresponding point on Y-axis, then we get estimated population data for the year (see graph). Thus, we get estimated data on the basis of recorded data.

Estimated data helps us plan for the future in the present. For example, population control can be planned in the present before it touches the estimated mark in reality.

Note:- It is supposed on the basis of estimated data for the year 2010 that the trend of increase in population will remain the same. It is not necessary that this will happen because many methods are being used to control population even now. How these efforts will affect the trend of data cannot be determined, we can only estimate on the basis of extrapolation.

Example-14. The population of a country over different years is shown in the graph. Analyze the graph and answer the following questions.

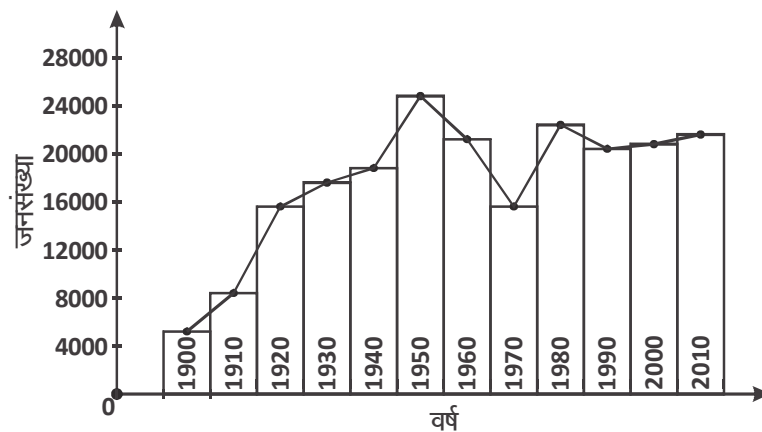

- In which year was the population maximum?
- What is the minimum population?
- In which years did population show an increase?
- In which years did the population fall?
- Was there a constant growth or fall in population in the initial five years?

Let us think more about this data.

If we consider data of first fifty years from 1900 to 1950 we see that population is continuously increasing. If we look at the population figures after this then population decreased from 1950 to 1970 and after that again recorded growth. The data from 1990 to 2010 also shows increasing population.

We find that the graph of population growth changed directions continuously. In different years the population sometimes increased and sometimes decreased and the direction of rate of growth changed – this is known as data trend. Data trends help us predict the value of data in the future.

Let us look at another example.

Example-15. The following graph shows figures related to production of fishes in a state.

Analyze the graph and answer the following questions:-

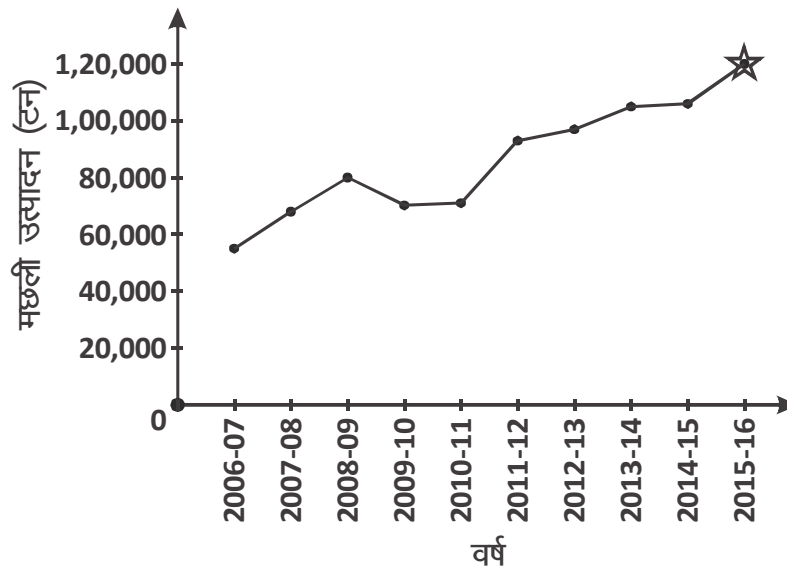

- How many ton of fish were produced in the year 2011-12?
- In which year was the production of fish maximum?
- Do we see a continuous increase in fish production?

In 2007, the state initiated a scheme called 'friend of fish' in which the ichthyology (fish) department tried to motivate the local community towards fish farming. Now, several thousand people from the community are involved with the department. They help the department identify suitable locations for cultivating fish and also play a role in collecting and maintaining important data about fish production.

Because of active involvement of the community, the state has seen a constant increase in production. If we extrapolate on the basis of previous figures, it is estimated that fish production will touch 1,20,000 ton mark in 2015-16.

Exercise - 2

1. Find the mean of the following data:-

Number of female teacher (in %)	15–25	25–35	35–45	45–55	55–65	65–75	75–85
No. of states	6	11	7	4	4	2	1

On the basis of this data draw 5 conclusions about female teachers.

2. Wickets taken by some bowlers in international cricket matches are given in the table. Find the mode of the data.

Number of wicket	0–50	50–100	100–150	150–200	200–250	250–300
Number of bowlers	4	5	16	12	3	2

Write 5 conclusions about this data.

3. Literacy rates (in percentage) of 35 cities are given in the following table. Find the mean of the data.

Literacy Rate (in %)	45–55	55–65	65–75	75–85	85–95
Number of Cities	3	10	11	8	3

Write 3 conclusions about this data.

4. The following table shows the ages of the patients admitted in a hospital during a year. Find the mean.

Age (in years)	5–15	15–25	25–35	35–45	45–55	55–65
Number of Patients	6	11	21	23	14	5

Write 3 conclusions about this data.

5. The following table shows marks obtained by the students in an examination-

Marks obtained	0-10	10-20	20-30	30-40	40-50	50-60
Number of students	1	12	24	32	10	5

Find the median of marks. Write 3 conclusions about the data.

What We Have Learnt

1. Bar graphs and tables are helpful in understanding data.
2. Observations are data-points under consideration in a particular situation.
3. Average is a number which is characteristic of the entire data.
4. Average lies between the maximum and the minimum value of the given data.
5. Average of data is known as arithmetic mean in statistics.
6. Mean, median and mode are representative values of data.
7. Median is the middle value of data organized in ascending or descending order.
8. Mode is the value that occurs maximum number of times in given data.
9. If there is lots of variation in data then mean of that data can be misleading.
10. To find median of series having individual observations we have to arrange data in ascending or descending order.
11. The difference between highest and lowest values (limits) of data is said to be its range. It shows the extent of variation in the data points.
12. The formula to find arithmetic mean in individual series is as follows:

$$\text{Arithmetic Mean} = \frac{\text{Sum of data}}{\text{Number of data}}$$

13. To find arithmetic mean of discrete and grouped series, the following formula is used:

$$\bar{X} = \frac{\sum f_i x_i}{\sum f_i}$$

14. To find median of individual series, if number of terms is odd then we use the following formula-

$$\text{Median} = \left(\frac{n+1}{2} \right)^{\text{th}} \text{ term}$$

And we use the following formula if number of data is even

$$\text{Median} = \frac{\left(\frac{n}{2} \right)^{\text{th}} \text{ term} + \left(\frac{n}{2} + 1 \right)^{\text{th}} \text{ term}}{2}$$

16. To find median of grouped data we use the following formula-

$$\text{Median} = \ell + \left(\frac{\frac{n}{2} - cf}{f} \right) \times h$$

17. To find mode of grouped data we use the following formula-

$$\text{Mode} = \ell + \left[\frac{f_1 - f_0}{2f_1 - f_0 - f_2} \right] \times h$$

18. With the help of a graph we can find data-points within the data range which are actually given. This is known as interpolation but it is not possible all data types.

19. In graphs, when we use the direction of increase or decrease of the curve to determine a value beyond the given data range, this is known as extrapolation. Extrapolation can be done only if the data shows a clear trend.

Answer Key - 1

1. (i) Mode (ii) Arithmetic Mean (iii) Median
(iv) Arithmetic mean (v) Mode (vi) Arithmetic mean
(vii) None of these
2. 278.47 mm 3. 11 4. Rupees 29.2
5. Arithmetic mean = 1.965 meter, median = 1.99 meter, mode = 2.02 meter
6. 35.75 kilogram

Answer Key - 2

1. 39.71% 2. 136.66 3. 69.42%
4. Mean = 35.37 5. 31.56

