



ಒಟ್ಟು ಮುದ್ರಿತ ಪುಟಗಳ ಸಂಖ್ಯೆ : 16]

Total No. of Printed Pages : 16]

ಒಟ್ಟು ಪ್ರಶ್ನೆಗಳ ಸಂಖ್ಯೆ : 38]

Total No. of Questions : 38]

ವಿಷಯ : ಗಣಿತ

Subject : MATHEMATICS

(ಇಂಗ್ಲಿಷ್ ಮಾಧ್ಯಮ / English Medium)

(ಶಾಲಾ ಅಭ್ಯರ್ಥಿ & ಪುನರಾವರ್ತಿತ ಶಾಲಾ ಅಭ್ಯರ್ಥಿ / Regular Fresh & Regular Repeater)

ದಿನಾಂಕ : 04. 04. 2022]

[Date : 04. 04. 2022

ಸಮಯ : ಬೆಳಿಗ್ಗೆ 10-30 ರಿಂದ ಮಧ್ಯಾಹ್ನ 1-45 ರವರೆಗೆ] [Time : 10-30 A.M. to 1-45 P.M.

ಗರಿಷ್ಠ ಅಂಕಗಳು : 80]

[Max. Marks : 80

General Instructions to the Candidate :

1. This question paper consists of objective and subjective types of 38 questions.
2. This question paper has been sealed by reverse jacket. You have to cut on the right side to open the paper at the time of commencement of the examination. Check whether all the pages of the question paper are intact.
3. Follow the instructions given against both the objective and subjective types of questions.
4. Figures in the right hand margin indicate maximum marks for the questions.
5. The maximum time to answer the paper is given at the top of the question paper. It includes 15 minutes for reading the question paper.



1. Four alternatives are given for each of the following questions / incomplete statements. Choose the correct alternative and write the complete answer along with its letter of alphabet.

 $8 \times 1 = 8$

1. The graphical representation of the pair of lines $x + 2y - 4 = 0$ and

$2x + 4y - 12 = 0$ is



- (A) intersecting lines
 (B) parallel lines
 (C) coincident lines
 (D) perpendicular lines.



2. The common difference of the Arithmetic progression $8, 5, 2, -1, \dots$

is



- (A) -3
 (B) -2
 (C) 3
 (D) 8 .





3. The standard form of $2x^2 = x - 7$ is

(A) $2x^2 - x = -7$



(B) $2x^2 + x - 7 = 0$

(C) $2x^2 - x + 7 = 0$



(D) $2x^2 + x + 7 = 0$

4. The value of $\cos (90^\circ - 30^\circ)$ is



(A) -1



(B) $\frac{1}{2}$

(C) 0



(D) 1



5. The distance of the point $P(x, y)$ from the origin is

(A) $\sqrt{x^2 + y^2}$

(B) $x^2 + y^2$

(C) $x^2 - y^2$

(D) $\sqrt{x^2 - y^2}$

6. In a circle, the angle between the tangent and the radius at the point of contact is

(A) 30°

(B) 60°

(C) 90°

(D) 180°

7. In the given figure, the volume of the frustum of a cone is

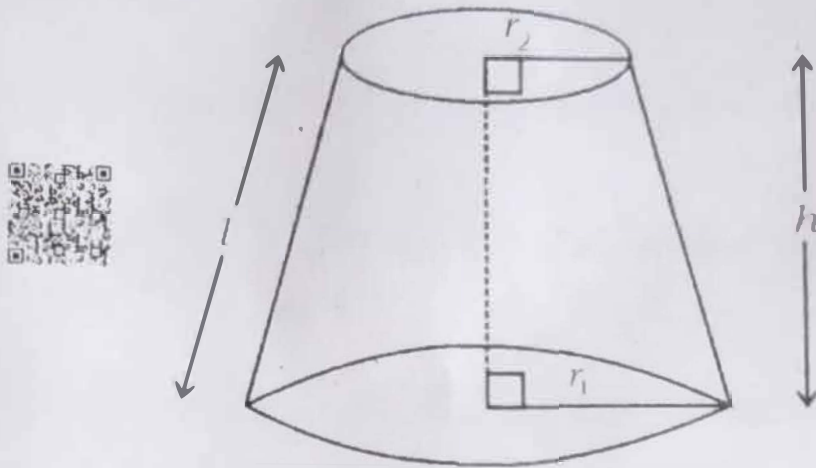

- (A) $\pi (r_1 + r_2) l$
- (B) $\pi (r_1 - r_2) l$
- (C) $\frac{1}{3} \pi h (r_1^2 - r_2^2 - r_1 r_2)$
- (D) $\frac{1}{3} \pi h (r_1^2 + r_2^2 + r_1 r_2)$

8. Surface area of a sphere of radius 'r' unit is

- (A) πr^2 sq. units
- (B) $2\pi r^2$ sq. units
- (C) $3\pi r^2$ sq. units
- (D) $4\pi r^2$ sq. units.



II. Answer the following questions :



$8 \times 1 = 8$

9. If the pair of linear equations in two variables are inconsistent, then

how many solutions do they have ?



10. In an Arithmetic progression if 'a' is the first term and 'd' is the

common difference, then write its n^{th} term.



11. Write the standard form of quadratic equation.

12. Write the value of $\frac{\sin 18^\circ}{\cos 72^\circ}$.



13. Write the distance of the point (4, 3) from x-axis.



14. Find the median of the scores 6, 4, 2, 10 and 7.



15. Write the statement of "Basic Proportionality" theorem (Thales theorem).

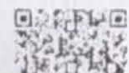



16. In the given figure, write the formula used to find the curved surface area of the cone.

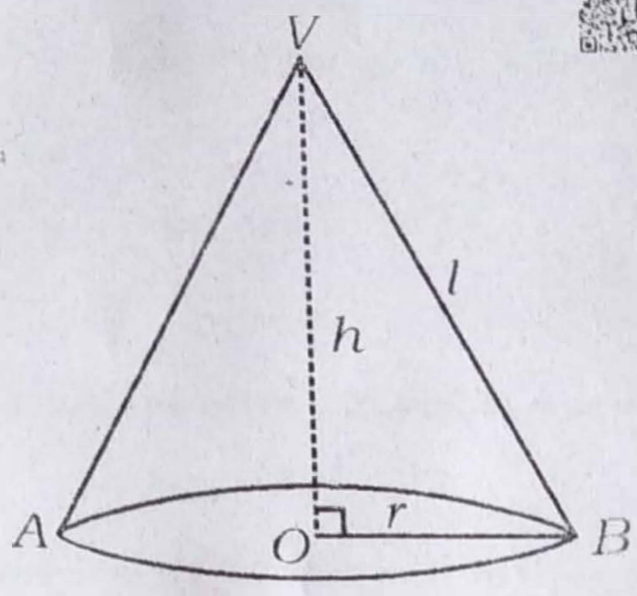

III. Answer the following questions :



8 × 2 = 16

17. Solve the given pair of linear equations by Elimination method :

$$2x + y = 8$$



$$x - y = 1$$



18. Find the 30th term of the arithmetic progression 5, 8, 11, by using formula.





19. Find the sum of first 20 terms of the Arithmetic progression

10, 15, 20, by using formula.



OR

Find the sum of first 20 positive integers using formula.



20. Find the roots of $x^2 + 5x + 2 = 0$ by using quadratic formula.

21. Find the value of the discriminant and hence write the nature of

roots of the quadratic equation $x^2 + 4x + 4 = 0$.



22. Find the distance between the points A (2, 6) and B (5, 10) by

using distance formula.



OR



Find the coordinates of the mid-point of the line segment joining the

points P (3, 4) and Q (5, 6) by using 'mid-point' formula.



23. Draw a line segment of length 10 cm and divide it in the ratio 2 : 3 by geometric construction.

24. In the given figure find the values of

i) $\sin \theta$

ii) $\tan \alpha$.

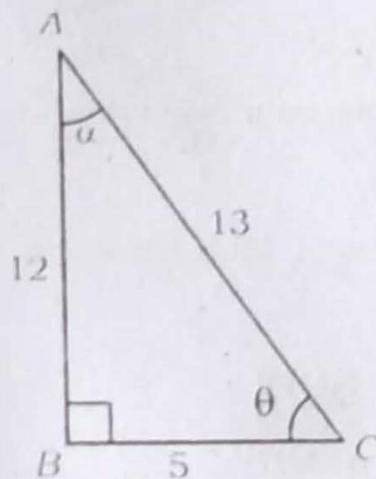

IV. Answer the following questions :

$$9 \times 3 = 27$$

25. The sum of first 9 terms of an Arithmetic progression is 144 and its 9th term is 28. Then find the first term and common difference of the Arithmetic progression.



26. The diagonal of a rectangular field is 60 m more than its shorter side. If the longer side is 30 m more than the shorter side, then find the sides of the field.



OR



- In a right angled triangle, the length of the hypotenuse is 13 cm. Among the remaining two sides, the length of one side is 7 cm more than the other side. Find the sides of the triangle.



27. Prove that



$$(\sin A + \operatorname{cosec} A)^2 + (\cos A + \sec A)^2 = 7 + \tan^2 A + \cot^2 A.$$



OR



Prove that $\sec \theta (1 - \sin \theta) (\sec \theta + \tan \theta) = 1.$



28. Find the coordinates of the point on the line segment joining the points $A(-1, 7)$ and $B(4, -3)$ which divides AB internally in the ratio $2 : 3$.

OR

- Find the area of triangle PQR with vertices $P(0, 4)$, $Q(3, 0)$ and $R(3, 5)$.

29. Find the mean for the following grouped data by Direct method :

<i>Class-interval</i>	<i>Frequency</i>
10 — 20	2
20 — 30	3
30 — 40	5
40 — 50	7
50 — 60	3

OR

Find the mode for the following grouped data :

<i>Class-interval</i>	<i>Frequency</i>
5 — 15	3
15 — 25	4
25 — 35	8
35 — 45	7
45 — 55	3

30. During a medical check-up of 50 students of a class, their heights were recorded as follows :

Draw "less than type" ogive for the given data :

<i>Height in cm</i>	<i>Number of students (Cumulative frequency)</i>
Less than 140	5
Less than 145	10
Less than 150	15
Less than 155	25
Less than 160	40
Less than 165	50



31. Prove that "the lengths of tangents drawn from an external point to a circle are equal".



32. Construct two tangents to a circle of radius 3 cm from a point 8 cm away from its centre.



33. The volume of a solid right circular cylinder is 2156 cm^3 . If the height of the cylinder is 14 cm, then find its curved surface area.

[Take $\pi = \frac{22}{7}$]



V. Answer the following questions :

4 × 4 = 16

34. Find the solution of the given pair of linear equations by graphical method :



$$x + 2y = 6$$



$$x + y = 5$$

35. The angle of elevation of the top of a building from the foot of a tower is 30° and the angle of elevation of the top of the tower from the foot of the building is 60° . Both the tower and building are on the same



level ground. If the height of the tower is 50 m, then find the height of the building.

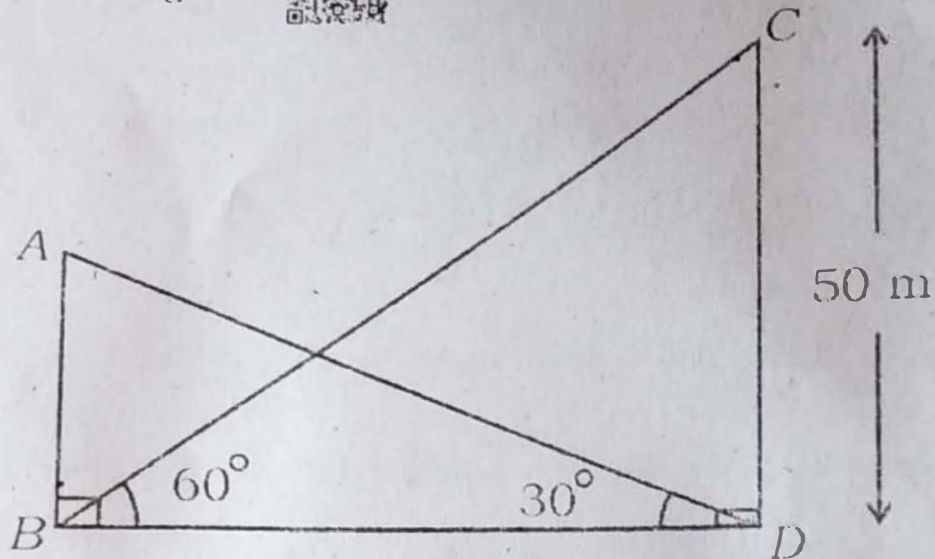

OR

As observed from the top of a 75 m high light house from the sea level, the angles of depression of two ships are 30° and 45° . If one ship is exactly behind the other on the same side of the light house then find the distance between the two ships.

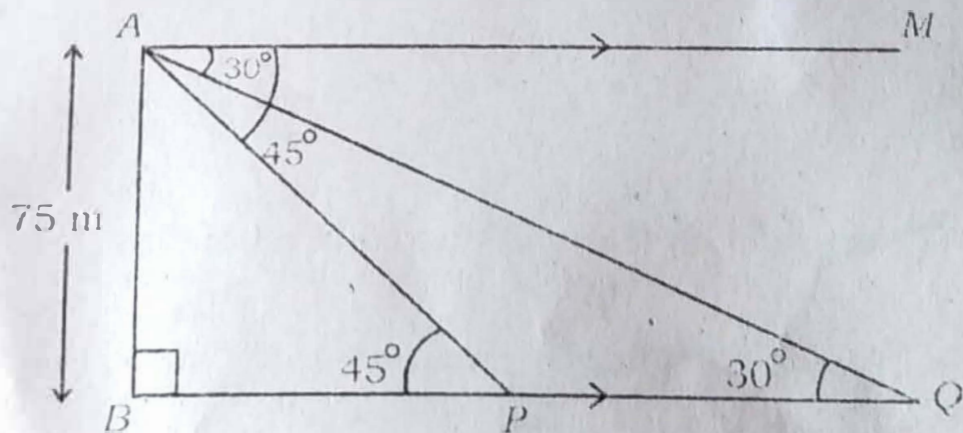

36. Construct a triangle with sides 4.5 cm, 6 cm and 8 cm. Then construct another triangle whose sides are $\frac{3}{4}$ of the corresponding sides of the first triangle.

37. In the figure AXB and CYD are the arcs of two concentric circles with centre O . The length of the arc AXB is 11 cm. If $OC = 7$ cm and $\angle AOB = 30^\circ$, then find the area of the shaded region.

[Take $\pi = \frac{22}{7}$]

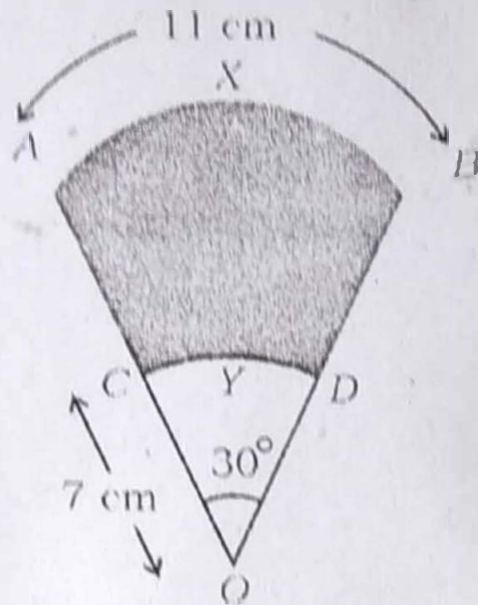

VI. Answer the following question :

$1 \times 5 = 5$

38. Prove that "the ratio of the areas of two similar triangles is equal to the square of the ratio of their corresponding sides".