

XE : ENGINEERING SCIENCES

Duration: Three Hours

Maximum Marks:100

Please read the following instructions carefully:

General Instructions:

1. Total duration of examination is 180 minutes (3 hours).
2. The clock will be set at the server. The countdown timer in the top right corner of screen will display the remaining time available for you to complete the examination. When the timer reaches zero, the examination will end by itself. You will not be required to end or submit your examination.
3. The Question Palette displayed on the right side of screen will show the status of each question using one of the following symbols:



You have not visited the question yet.



You have not answered the question.



You have answered the question.



You have NOT answered the question, but have marked the question for review.



You have answered the question, but marked it for review.

The Marked for Review status for a question simply indicates that you would like to look at that question again. ***If a question is answered and Marked for Review, your answer for that question will be considered in the evaluation.***

Navigating to a Question

4. To answer a question, do the following:
 - a. Click on the question number in the Question Palette to go to that question directly.
 - b. Select an answer for a multiple choice type question. Use the virtual numeric keypad to enter a number as answer for a numerical type question.
 - c. Click on **Save and Next** to save your answer for the current question and then go to the next question.
 - d. Click on **Mark for Review and Next** to save your answer for the current question, mark it for review, and then go to the next question.
 - e. **Caution: Note that your answer for the current question will not be saved, if you navigate to another question directly by clicking on its question number.**
5. You can view all the questions by clicking on the **Question Paper** button. Note that the options for multiple choice type questions will not be shown.

Answering a Question

6. Procedure for answering a multiple choice type question:
 - a. To select your answer, click on the button of one of the options
 - b. To deselect your chosen answer, click on the button of the chosen option again or click on the **Clear Response** button
 - c. To change your chosen answer, click on the button of another option
 - d. To save your answer, you MUST click on the **Save and Next** button

- e. To mark the question for review, click on the **Mark for Review and Next** button. *If an answer is selected for a question that is Marked for Review, that answer will be considered in the evaluation.*
7. Procedure for answering a numerical answer type question:
 - a. To enter a number as your answer, use the virtual numerical keypad
 - b. A fraction (eg., -0.3 or -.3) can be entered as an answer with or without '0' before the decimal point
 - c. To clear your answer, click on the **Clear Response** button
 - d. To save your answer, you **MUST** click on the **Save and Next** button
 - e. To mark the question for review, click on the **Mark for Review and Next** button. *If an answer is entered for a question that is Marked for Review, that answer will be considered in the evaluation.*
8. To change your answer to a question that has already been answered, first select that question for answering and then follow the procedure for answering that type of question.
9. Note that **ONLY** Questions for which answers are saved or marked for review after answering will be considered for evaluation.

Choosing an Optional Section

10. Sections in this question paper are displayed on the top bar of the screen. Questions in a Section can be viewed by clicking on the name of that Section. The Section you are currently viewing is highlighted.
11. A checkbox is displayed for every optional Section in the Question Paper. To select an optional Section for answering, click on the checkbox for that Section.
12. If the checkbox for an optional Section is not selected, the **Save and Next** button and the **Mark for Review and Next** button will **NOT** be enabled for that Section. You will be able to only see questions in the Section, but you will not be able to answer questions in the Section.
13. After clicking the **Save and Next** button for the last question in a Section, you will automatically be taken to the first question of the next Section in sequence.
14. You can move the mouse cursor over the name of a Section to view the answering status for that Section.

Changing the Optional Section

15. After answering the chosen optional Sections, partially or completely, you can change an optional Section by selecting a checkbox for a new Section that you want to attempt. A warning message will appear along with a table showing the number of questions answered in each of the previously chosen optional Sections and a checkbox against each of these Sections. Click on a checkbox against a Section that you want to reset and then click on the **RESET** button. **Note that RESETTING a Section will DELETE all the answers for questions in that Section. Hence, if you think that you may want to select this Section again later, you will have to note down your answers for questions in that Section.** If you do not want to reset any Section and want to continue answering the previously chosen optional Sections, then click on the **BACK** button.
16. If you deselect the checkbox for an optional Section in the top bar, the following warning message will appear: "Deselecting the checkbox will **DELETE** all the answers for questions in this Section. Do you want to deselect this Section?" If you want to deselect, click on the **RESET** button. If you do not want to deselect, click on the **BACK** button.
17. You can shuffle between different Sections any number of times. You can change the optional Sections any number of times.

Paper specific instructions:

1. There are a total of 65 questions carrying 100 marks. The question paper consists of questions of multiple choice type and numerical answer type. Multiple choice type questions will have four choices for the answer with only **one** correct choice. For numerical answer type questions, the answer is a number and no choices will be given. **A number as the answer should be entered** using the virtual keyboard on the monitor.
2. There are **Eight** sections: **GA** (General Aptitude), **A** (Engineering Mathematics), **B** (Fluid Mechanics), **C** (Materials Science), **D** (Solid Mechanics), **E** (Thermodynamics), **F** (Polymer Science & Engineering) and **G** (Food Technology).
3. Section **GA** (General Aptitude) and Section **A** (Engineering Mathematics) are compulsory. Attempt any **two** optional Sections **B** through **G**.
4. There are 10 questions carrying 15 marks in General Aptitude (**GA**) section, which is compulsory. Questions Q.1 – Q.5 carry 1 mark each, and questions Q.6 – Q.10 carry 2 marks each.
5. There are 11 questions carrying 15 marks in Section **A** (Engineering Mathematics), which is compulsory. Questions Q.1 - Q.7 carry 1 mark each and questions Q.8- Q.11 carry 2 marks each.
6. Each of the other sections (Sections **B** through **G**) contains 22 questions carrying 35 marks. Questions Q.1 - Q.9 carry 1 mark each and questions Q.10 - Q.22 carry 2 marks each. The 2 marks questions include two pairs of common data questions and one pair of linked answer questions. The answer to the second question of the linked answer questions depends on the answer to the first question of the pair. If the first question in the linked pair is wrongly answered or is not attempted, then the answer to the second question in the pair will not be evaluated
7. Questions not attempted will result in zero mark. Wrong answers for multiple choice type questions will result in **NEGATIVE** marks. For all 1 mark questions, $\frac{1}{3}$ mark will be deducted for each wrong answer. For all 2 marks questions, $\frac{2}{3}$ mark will be deducted for each wrong answer. However, in the case of the linked answer question pair, there will be negative marks only for wrong answer to the first question and no negative marks for wrong answer to the second question. There is no negative marking for questions of numerical answer type.
8. Calculator is allowed. Charts, graph sheets or tables are **NOT** allowed in the examination hall.
9. Do the rough work in the Scribble Pad provided.

General Aptitude (GA) Questions

Q. 1 – Q. 5 carry one mark each.

Q.1 If $3 \leq X \leq 5$ and $8 \leq Y \leq 11$ then which of the following options is TRUE?

(A) $\frac{3}{5} \leq \frac{X}{Y} \leq \frac{8}{5}$

(B) $\frac{3}{11} \leq \frac{X}{Y} \leq \frac{5}{8}$

(C) $\frac{3}{11} \leq \frac{X}{Y} \leq \frac{8}{5}$

(D) $\frac{3}{5} \leq \frac{X}{Y} \leq \frac{8}{11}$

Q.2 The Headmaster _____ to speak to you.

Which of the following options is incorrect to complete the above sentence?

(A) is wanting

(B) wants

(C) want

(D) was wanting

Q.3 Mahatma Gandhi was known for his humility as

(A) he played an important role in humiliating exit of British from India.

(B) he worked for humanitarian causes.

(C) he displayed modesty in his interactions.

(D) he was a fine human being.

Q.4 All engineering students should learn mechanics, mathematics and how to do computation.

I

II

III

IV

Which of the above underlined parts of the sentence is not appropriate?

(A) I

(B) II

(C) III

(D) IV

Q.5 Select the pair that best expresses a relationship similar to that expressed in the pair:

water: pipe::

(A) cart: road

(B) electricity: wire

(C) sea: beach

(D) music: instrument

Q. 6 to Q. 10 carry two marks each.

- Q.6 Velocity of an object fired directly in upward direction is given by $V = 80 - 32t$, where t (time) is in seconds. When will the velocity be between 32 m/sec and 64 m/sec?
- (A) (1, 3/2) (B) (1/2, 1)
 (C) (1/2, 3/2) (D) (1, 3)
- Q.7 In a factory, two machines M1 and M2 manufacture 60% and 40% of the autocomponents respectively. Out of the total production, 2% of M1 and 3% of M2 are found to be defective. If a randomly drawn autocomponent from the combined lot is found defective, what is the probability that it was manufactured by M2?
- (A) 0.35 (B) 0.45 (C) 0.5 (D) 0.4
- Q.8 Following table gives data on tourists from different countries visiting India in the year 2011.

Country	Number of Tourists
USA	2000
England	3500
Germany	1200
Italy	1100
Japan	2400
Australia	2300
France	1000

- Which two countries contributed to the one third of the total number of tourists who visited India in 2011?
- (A) USA and Japan
 (B) USA and Australia
 (C) England and France
 (D) Japan and Australia
- Q.9 If $|-2X + 9| = 3$ then the possible value of $|-X| - X^2$ would be:
- (A) 30 (B) -30 (C) -42 (D) 42
- Q.10 All professors are researchers
 Some scientists are professors
- Which of the given conclusions is logically valid and is inferred from the above arguments:
- (A) All scientists are researchers
 (B) All professors are scientists
 (C) Some researchers are scientists
 (D) No conclusion follows

A: ENGINEERING MATHEMATICS

Q. 1 – Q. 7 carry one mark each.

Q.1 The value of the integral $\int_0^1 \frac{dt}{\sqrt{(-\log_e t)}}$ is

- (A) $\frac{\sqrt{\pi}}{2}$ (B) $\sqrt{\pi}$ (C) $-\sqrt{\pi}$ (D) $-\frac{\sqrt{\pi}}{2}$

Q.2 Which one of the following partial differential equations **CAN NOT** be reduced to two ordinary differential equations by the method of separation of variables?

- (A) $\frac{\partial u}{\partial t} - \frac{\partial^2 u}{\partial x^2} = 0$ (B) $\frac{\partial^2 u}{\partial t^2} - \frac{\partial^2 u}{\partial x^2} = 0$
 (C) $\frac{\partial^2 u}{\partial t^2} + \frac{\partial^2 u}{\partial t \partial x} + \frac{\partial u}{\partial x} = 0$ (D) $\frac{\partial^2 u}{\partial t^2} + \frac{\partial^2 u}{\partial t \partial x} + \frac{\partial^2 u}{\partial x^2} = 0$

Q.3 The Fourier series of the periodic function

$$f(x) = |x|, \quad -1 < x < 1, \quad f(x+2) = f(x), \quad x \in \mathbb{R}$$

is given by

$$\frac{1}{2} - \sum_{n=1}^{\infty} \frac{4 \cos(2n-1)\pi x}{(2n-1)^2 \pi^2}.$$

Using the above, the sum of the infinite series $1 + \frac{1}{3^2} + \frac{1}{5^2} + \dots$ is

- (A) $\frac{\pi^2}{4}$ (B) $\frac{3\pi^2}{8}$ (C) $\frac{\pi^2}{8}$ (D) $\frac{\pi^2}{2}$

Q.4 Consider the function $f(z) = z^2 \bar{z}$, $z \in \mathbb{C}$. At $z = 0$, the function f

- (A) does not satisfy the Cauchy-Riemann equations
 (B) satisfies the Cauchy-Riemann equations but is not differentiable
 (C) is differentiable but not analytic
 (D) is analytic

Q.5 The integral $\oint_C \frac{(z+4)}{(z+1)(z-2)^3} dz$ along the contour $C: |z - (1 + i)| = 2$, oriented anti-clockwise, is equal to

- (A) 0 (B) $\frac{2\pi i}{9}$ (C) $-\frac{2\pi i}{9}$ (D) $\frac{4\pi i}{9}$

Q.6 The integral $\int_0^1 \int_{x^2}^x \left(\frac{x}{y}\right) e^{-x^2/y} dy dx$ equals

- (A) $\frac{e-2}{e}$ (B) $\frac{e-1}{2e}$ (C) $\frac{e-1}{2}$ (D) $\frac{e-2}{2e}$

Q.7 If the mean and variance of a binomial distribution are 6 and 2 respectively, then the probability of two failures is

- (A) $4\left(\frac{2}{3}\right)^7$ (B) $4\left(\frac{2^2}{3^7}\right)$ (C) $17\left(\frac{2}{3}\right)^7$ (D) $17\left(\frac{2^2}{3^7}\right)$

Q. 8 - Q. 11 carry two marks each.

Q.8 For the matrix $M = \begin{pmatrix} 1 & 0 & -1 \\ 0 & 1 & -1 \\ 1 & 1 & -2 \end{pmatrix}$, consider the following statements:

- (P) The characteristic equation of M is $\lambda^3 - \lambda = 0$.
 (Q) M^{-1} does not exist.
 (R) The matrix M is diagonalizable.

Which of the above statements are true?

- (A) P, Q and R (B) P and R but not Q
 (C) P and Q but not R (D) Q and R but not P

Q.9 The work done by the force $\vec{F} = (x + x^2)\hat{i} + (x^2 + y^3)\hat{j}$ in moving a particle once along the triangle with vertices $(0,0)$, $(1,0)$ and $(0,1)$ in the anti-clockwise direction is

- (A) 0 (B) 1/6 (C) 1/3 (D) 5/3

Q.10 The general solution of the differential equation

$$x^3 \frac{d^3y}{dx^3} + x^2 \frac{d^2y}{dx^2} + x \frac{dy}{dx} - y = 0, \quad x > 0$$

is

- (A) $C_1 e^x + e^{x/2} \left\{ C_2 \cos\left(\frac{\sqrt{3}}{2}x\right) + C_3 \sin\left(\frac{\sqrt{3}}{2}x\right) \right\}$
(B) $C_1 x + x^{-1/2} \left\{ C_2 \cos\left(\frac{\sqrt{3}}{2} \log_e x\right) + C_3 \sin\left(\frac{\sqrt{3}}{2} \log_e x\right) \right\}$
(C) $C_1 e^x + e^{-x/2} \left\{ C_2 \cos\left(\frac{\sqrt{3}}{2}x\right) + C_3 \sin\left(\frac{\sqrt{3}}{2}x\right) \right\}$
(D) $C_1 x + x^{1/2} \left\{ C_2 \cos\left(\frac{\sqrt{3}}{2} \log_e x\right) + C_3 \sin\left(\frac{\sqrt{3}}{2} \log_e x\right) \right\}$

Q.11 Using Euler's method to solve the differential equation

$$\frac{dy}{dx} = 2 \cos\left(\frac{4\pi x}{3}\right) - y, \quad y(0) = 1$$

with step-size $h = 0.25$, the value of $y(0.5)$ is

- (A) 1.3125 (B) 1.1875 (C) 1.125 (D) 1.0625

END OF SECTION - A

B:FLUID MECHANICS

Q. 1 – Q. 9 carry one mark each.

- Q.1 The gauge pressure inside a soap bubble of radius R , with σ denoting the surface tension between the soap solution and air, is.
- (A) $\frac{\sigma}{2\pi R}$ (B) $\frac{4\sigma}{R}$ (C) $\frac{2\sigma}{R}$ (D) $\frac{\sigma}{4\pi R}$
- Q.2 Let M , B and G represent respectively the metacentre, centre of buoyancy and the centre of mass of a floating buoy. Which of the following statements is correct?
- (A) M is above G ; Buoy unstable (B) B is above G ; Buoy stable
 (C) M is above G ; Buoy stable (D) B is above G ; Buoy unstable
- Q.3 A reservoir connected to a pipe line is being filled with water, as shown in the Figure. At any time t , the free surface level in the reservoir is h . Find the time in seconds for the reservoir to get filled up to a height of 1 m, if the initial level is 0.2 m. _____

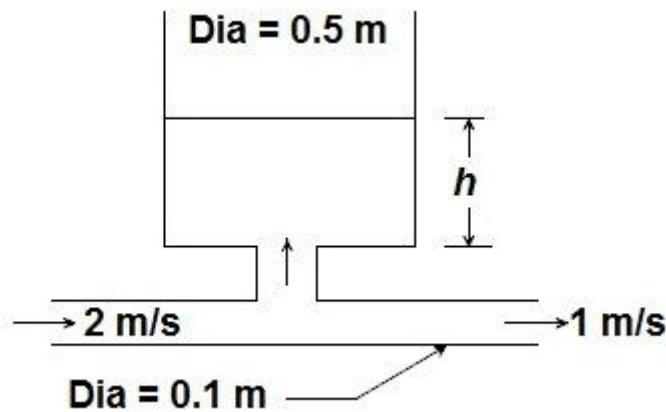

- Q.4 Bernoulli's equation is valid for the following type of flow:
- (A) Compressible, steady, inviscid (B) Incompressible, steady, viscous
 (C) Compressible, unsteady, viscous (D) Incompressible, steady, inviscid
- Q.5 If A is the area of a circle of radius r enclosing a plane forced vortex flow, with origin at the centre of the vortex and if ω is the angular velocity, ζ is the vorticity, \vec{V} is the velocity vector, then the circulation around the contour of the circle is given by
- (A) $2\omega A$ (B) $2\zeta A$ (C) $2\vec{V}A$ (D) 0
- Q.6 Flow past a circular cylinder can be produced by superposition of the following elementary potential flows:
- (A) Uniform flow, doublet (B) Uniform flow, vortex
 (C) Source, vortex (D) Sink, vortex
- Q.7 Let δ , δ_1 and δ_2 denote respectively the boundary-layer thickness, displacement thickness and the momentum thickness for laminar boundary layer flow of an incompressible fluid over a flat plate. The correct relation among these quantities is
- (A) $\delta < \delta_1 < \delta_2$ (B) $\delta > \delta_1 > \delta_2$ (C) $\delta > \delta_1 < \delta_2$ (D) $\delta < \delta_1 > \delta_2$

- Q.8 In the hydrodynamic entry region of a circular duct, the pressure forces balance the sum of
- (A) viscous and buoyancy forces (B) inertia and buoyancy forces
 (C) inertia and surface tension forces (D) inertia and viscous forces
- Q.9 Bodies with various cross-sectional shapes subjected to cross-flow of air are shown in the following figures. The characteristic dimension of all the shapes is the same. The cross-sectional shape with the largest coefficient of drag (i.e. sum of the pressure and skin-friction drags), at any moderately large Reynolds number, is

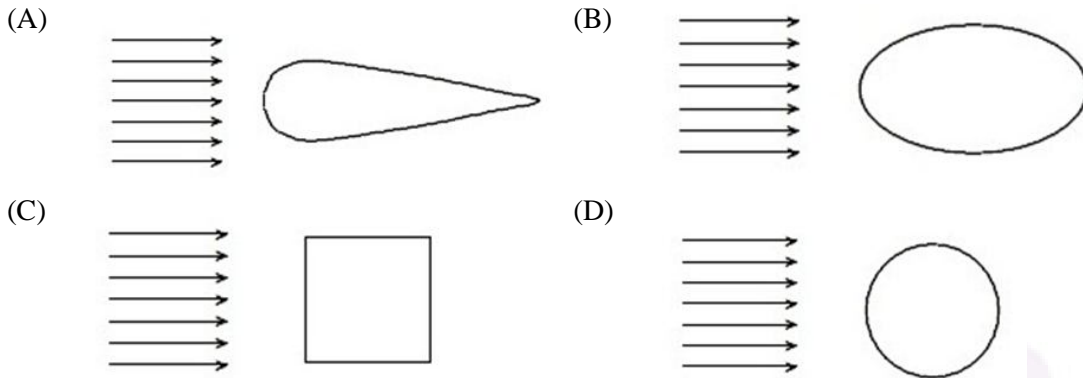

Q. 10 - Q. 22 carry two marks each.

- Q.10 A U-tube of a very small bore, with its limbs in a vertical plane and filled with a liquid of density ρ , up to a height of h , is rotated about a vertical axis, with an angular velocity of ω , as shown in the Figure. The radius of each limb from the axis of rotation is R . Let p_a be the atmospheric pressure and g , the gravitational acceleration. The angular velocity at which the pressure at the point O becomes half of the atmospheric pressure is given by

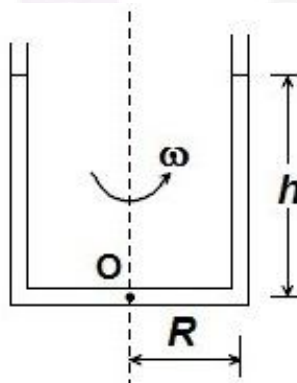

- (A) $\sqrt{\frac{p_a + 2\rho gh}{\rho R^2}}$ (B) $\sqrt{\frac{2(p_a + \rho gh)}{\rho R^2}}$
 (C) $\sqrt{\frac{p_a + 2\rho gh}{2\rho R^2}}$ (D) $\sqrt{\frac{p_a + \rho gh}{2\rho R^2}}$

- Q.11 An incompressible fluid at a pressure of 150 kPa (absolute) flows steadily through a two-dimensional channel with a velocity of 5 m/s as shown in the Figure. The channel has a 90° bend. The fluid leaves the channel with a pressure of 100 kPa (absolute) and linearly-varying velocity profile. v_{\max} is four times v_{\min} . The density of the fluid is 914.3 kg/m^3 . The velocity v_{\min} , in m/s, is

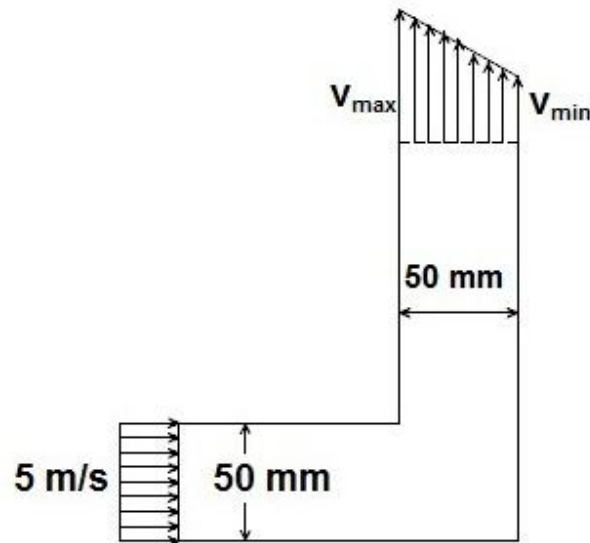

- (A) 25 (B) 2.5 (C) 2.0 (D) 0.2
- Q.12 The velocity vector corresponding to a flow field is given, with usual notation, by $\vec{V} = 3x \hat{i} + 4xy \hat{j}$. The magnitude of rotation at the point (2,2) in rad/s is
- (A) 0.75 (B) 1.33 (C) 2 (D) 4
- Q.13 The stream function for a potential flow field is given by $\psi = x^2 - y^2$. The corresponding potential function, assuming zero potential at the origin, is
- (A) $x^2 + y^2$ (B) $2xy$ (C) $x^2 - y^2$ (D) $x - y$
- Q.14 Fully developed flow of an oil takes place in a pipe of inner diameter 50 mm. The pressure drop per metre length of the pipe is 2 kPa. Determine the shear stress, in Pa, at the pipe wall. _____
- Q.15 The Darcy friction factor f for a smooth pipe is given by $f = 64/\text{Re}$ for laminar flow and by $f = 0.3/\text{Re}^{0.25}$ for turbulent flow, where Re is the Reynolds number based on the diameter. For fully developed flow of a fluid of density 1000 kg/m^3 and dynamic viscosity $0.001 \text{ Pa}\cdot\text{s}$ through a smooth pipe of diameter 10 mm with a velocity of 1 m/s, determine the Darcy friction factor. _____
- Q.16 Air flows steadily through a channel. The stagnation and static pressures at a point in the flow are measured by a Pitot tube and a wall pressure tap, respectively. The pressure difference is found to be 20 mm Hg. The densities of air, water and mercury, in kg/m^3 , are 1.18, 1000 and 13600, respectively. The gravitational acceleration is 9.81 m/s^2 . Determine the air speed in m/s. _____

Common Data Questions

Common Data for Questions 17 and 18:

The velocity field within a laminar boundary layer is given by the expression:

$$\vec{V} = \frac{Bu_{\infty}y}{x^{3/2}}\hat{i} + \frac{Bu_{\infty}y^2}{4x^{5/2}}\hat{j}$$

where $B = 100 \text{ m}^{1/2}$ and the free stream velocity $u_{\infty} = 0.1 \text{ m/s}$.

Q.17 Calculate the x -direction component of the acceleration in m/s^2 at the point $x = 0.5 \text{ m}$ and $y = 50 \text{ mm}$. _____

Q.18 Find the slope of the streamline passing through the point $x = 0.5 \text{ m}$ and $y = 50 \text{ mm}$. _____

Common Data for Questions 19 and 20:

The wave and eddy resistance of a sea-going vessel, 96 m in length, driven at a velocity of 12 m/s, is to be determined. For this purpose, a 1/16 th scale model is employed in fresh water and the coefficient of resistance C_{we} of the model is found to be 1.47×10^{-4} . The quantity C_{we} is defined as $F_{we}/(\rho V^2 L^2/2)$, where F_{we} is the wave and eddy resistance, ρ is the density, V is the velocity and L is the characteristic length. The density of sea water is 1026 kg/m^3 .

Q.19 The velocity in m/s, at which the model is towed, is

- (A) 0.75 (B) 1.33 (C) 3 (D) 192

Q.20 The resistance of the prototype, in kN, is

- (A) 6 (B) 25 (C) 26.9 (D) 100.1

Linked Answer Questions

Statement for Linked Answer Questions 21 and 22:

Water enters a symmetric forked pipe and discharges into atmosphere through the two branches as shown in the Figure. The cross-sectional area of section-1 is 0.2 m^2 and the velocity across section-1 is 3 m/s . The density of water may be taken as 1000 kg/m^3 . The viscous effects and elevation changes may be neglected.

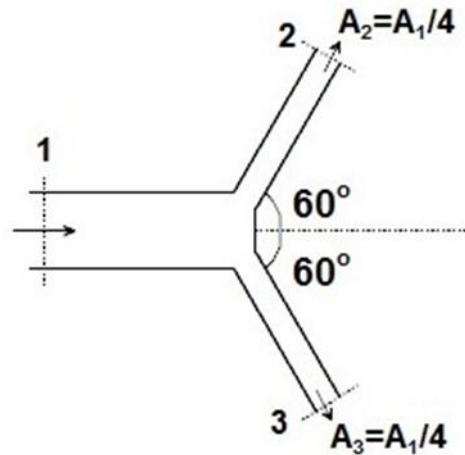

- Q.21 The gauge pressure at section-1, in kPa, is
(A) 0.6 (B) 13.5 (C) 135 (D) 600
- Q.22 The magnitude of the force, in kN, required to hold the pipe in place, is
(A) 2.7 (B) 5.4 (C) 19 (D) 27

END OF SECTION - B

C: MATERIALS SCIENCE

Useful Data:

Avogadro's Number	: $6.023 \times 10^{23} \text{ mol}^{-1}$
Boltzmann's constant, k	: $1.38 \times 10^{-23} \text{ J.K}^{-1}$
Electron Charge, e	: $1.6 \times 10^{-19} \text{ C}$
Electron rest mass, m_o	: $9.1 \times 10^{-31} \text{ kg}$
Gas Constant, R	: $8.314 \text{ J.mol}^{-1}\text{K}^{-1}$
Free Space Permittivity, ϵ_o	: $8.854 \times 10^{-12} \text{ F.m}^{-1}$
Free Space magnetic permeability, μ_o	: $4\pi \times 10^{-7} \text{ H.m}^{-1}$
Speed of light, c	: $3 \times 10^8 \text{ m.s}^{-1}$
Planck's constant, h	: $6.63 \times 10^{-34} \text{ J.s}^{-1}$
Bohr Magneton, μ_b	: $9.27 \times 10^{-24} \text{ A m}^2$
1 eV = $1.6 \times 10^{-19} \text{ J}$	
1 calorie = 4.2 J	

Q. 1 – Q. 9 carry one mark each.

- Q.1 As temperature increases, diffusivity of an atom in a solid material,
 (A) increases (B) decreases
 (C) remains constant (D) depends on the specific material
- Q.2 Which of the following is NOT correct?
 (A) Dislocations are thermodynamically unstable defects.
 (B) Dislocations can move inside a crystal under the action of an applied stress.
 (C) Screw dislocations can change the slip plane without climb
 (D) Burger's vector of an edge dislocation is parallel to the dislocation line.
- Q.3 At a constant atmospheric pressure, the number of phases, P which coexist in a chosen system at equilibrium, is related to the number of components, C in the system and the degree of freedom, F by
 (A) $P+F=C-2$ (B) $P+F=C+2$
 (C) $P+F=C+1$ (D) $P+F=C-1$
- Q.4 Which one of the following metals is commonly alloyed with iron to improve its corrosion resistance?
 (A) Co (B) Cr (C) Ti (D) Nb
- Q.5 The number of slip systems in a metal with FCC crystal structure is
 (A) 4 (B) 6 (C) 8 (D) 12
- Q.6 Upon recrystallization of a cold worked metal,
 (A) strength increases and ductility decreases
 (B) strength decreases but ductility increases
 (C) both strength and ductility increase
 (D) both strength and ductility decrease

- Q.7 In carbon fiber reinforced resin composites, for a given fiber volume content, Young's modulus depends on the orientation of the fiber with respect to the applied load. Which orientation of the fibers will give the maximum value of Young's modulus?
- (A) transverse (B) longitudinal
(C) random (D) both transverse and longitudinal
- Q.8 Vulcanization is related to
- (A) strengthening of rubber (B) extrusion
(C) injection moulding (D) addition polymerisation
- Q.9 Which one of the following oxides crystallizes into fluorite structure?
- (A) UO_2 (B) MgO (C) BaTiO_3 (D) MgAl_2O_4

Q. 10 - Q. 22 carry two marks each.

- Q.10 Match the conventional ceramic materials listed in **Column I** with their respective common applications in **Column II**

<u>Column I</u>	<u>Column II</u>
P. Lead Zirconate Titanate (PZT)	1. cutting tool
Q. Zinc Oxide (ZnO)	2. thermal barrier coating
R. Silicon Carbide (SiC)	3. actuator
S. Zirconia (ZrO_2)	4. varistor
	5. super conductor
(A) P-1, Q-2, R-3, S-5	(B) P-3, Q-2, R-1, S-5
(C) P-2, Q-1, R-5, S-3	(D) P-3, Q-4, R-1, S-2

- Q.11 Match the terminologies given in **Column I** with their relations listed in **Column II**

<u>Column I</u>	<u>Column II</u>
P. domain wall	1. superconductors
Q. Fick's law	2. mechanical properties
R. Matthiessen's rule	3. ferromagnetic materials
S. Hall-Petch relation	4. resistivity of impure metals
T. Meissner effect	5. diffusion
(A) P-1, Q-3, R-5, S-2, T-4	(B) P-3, Q-5, R-2, S-4, T-1
(C) P-3, Q-5, R-4, S-2, T-1	(D) P-3, Q-4, R-3, S-2, T-4

- Q.12 Match the microscopes listed in **Column I** with their principle of operation listed in **Column II**

<u>Column I</u>	<u>Column II</u>
P. Scanning Electron Microscope (SEM)	1. van der Waals forces between atoms
Q. Transmission Electron Microscope (TEM)	2. electrons to jump across a potential barrier
R. Scanning Tunnelling Microscope (STM)	3. diffraction of electrons
S. Atomic Force Microscope (AFM)	4. detection of secondary electrons
	5. photo emission of electrons
(A) P-2, Q-5, R-3, S-1	(B) P-3, Q-4, R-5, S-2
(C) P-4, Q-3, R-2, S-1	(D) P-4, Q-3, R-5, S-2

- Q.13 X-rays of unknown wavelength are diffracted by an FCC metal with a lattice parameter of 0.352 nm. The measured '2 θ ' angle for the {200} peak is 61.08°. Calculate the wavelength of the X-ray used, in nm. _____
- Q.14 A metal with HCP crystal structure has lattice constants $a = 0.30$ nm and $c = 0.56$ nm. Determine the volume of the unit cell of this metal, in nm³. _____
- Q.15 The band gap of a semiconducting material used to make an LED is 1.43 eV. What will be the minimum wavelength of the radiation emitted by this LED, in μm ? _____
- Q.16 For automatic control of household electric water heater a relay switch is activated by thermal expansion of a brass rod of length 50 cm as shown in the schematic below. The distance between the rod and the lever, x , is adjusted by moving the base of the rod. As the water gets heated the rod expands and as soon as the rod touches the lever, the circuit is broken disconnecting the heater from the power supply. Find the distance, x , in mm, to be set at water temperature of 20°C such that the circuit is broken at 70°C. The coefficient of linear thermal expansion of brass is $20 \times 10^{-6} \text{ } ^\circ\text{C}^{-1}$ _____

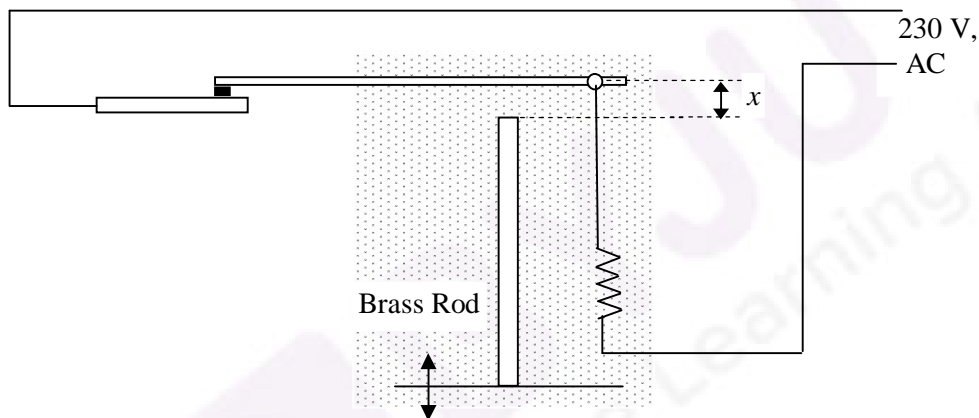

Common Data Questions

Common Data for Questions 17 and 18:

From tensile test of a particular alloy the following values were obtained. The material exhibits linear work hardening as shown in the figure given below.

	At Yield	At Fracture
Stress, GPa	0.7	0.8
Strain, %	1	4

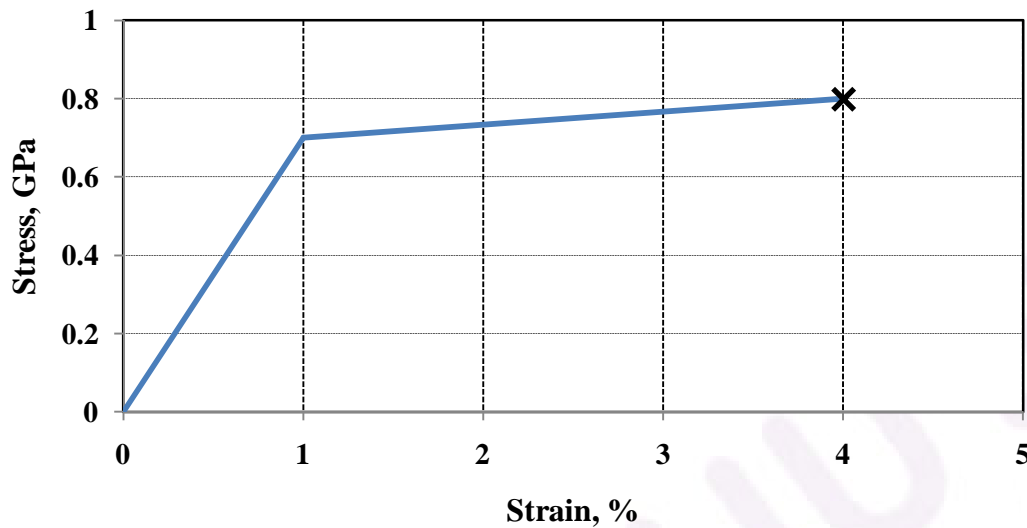

- Q.17 If the cylindrical specimen had a dimension of diameter 10 mm and length 50 mm, find the length of the specimen at the yield point, in mm. _____
- Q.18 Find the toughness of the material, in M J m^{-3} . _____

Common Data for Questions 19 and 20:

An isomorphous alloy system contains 47 wt% of A and 53 wt % of B and is at 1300° C. Referring to the figure given below, answer the following:

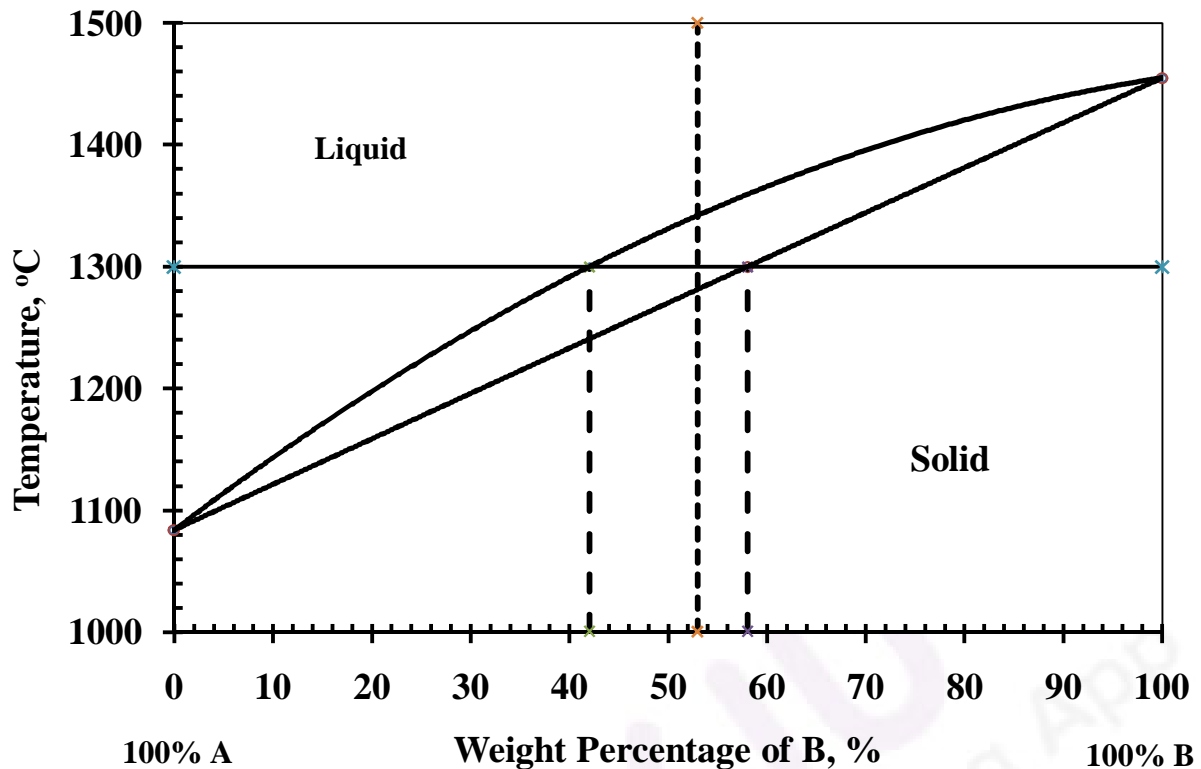

Q.19 What is the weight percentage of A in solid phase at this temperature? _____

Q.20 What weight percentage of this alloy is liquid? _____

Linked Answer Questions

Statement for Linked Answer Questions 21 and 22:

A stress of 10 MPa is applied to an elastomer to generate a strain of 50%. The strain is held constant at this value. After 40 days at 20°C, the stress decreases to 5 MPa.

Q.21 What is the relaxation time constant for this material? _____

Q.22 What will be the stress after 60 days at 20°C? _____

END OF SECTION - C

D :SOLID MECHANICS

Q. 1 – Q. 9 carry one mark each.

- Q.1 At a point in a body subjected to plane stress, the state of stress is as shown in the Figure. One of the principal stresses is 180 MPa. Find the unknown shear stress τ (in MPa). _____

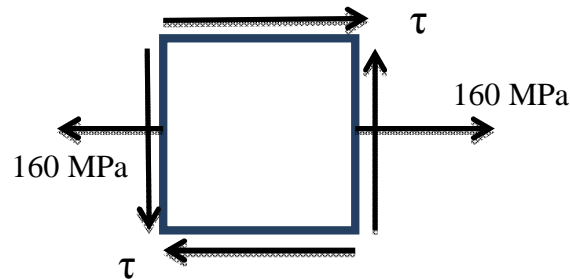

- Q.2 A point in a body is subjected to a hydrostatic pressure of 100 MPa. Find the maximum shear stress at this point in MPa. _____
- Q.3 A circular shaft of diameter 10 mm and length 3m is subjected to a torque of $T = \pi$ N-m at a location 2m away from the fixed end as shown in the Figure. Find out the angle of twist (in radians) at the free end. Shear modulus of the material of the shaft is 10 GPa. _____

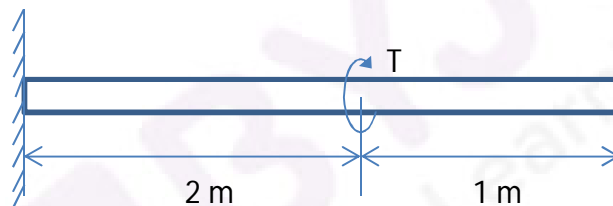

- Q.4 A rigid massless rod ABC is hinged at A and carries a point mass M (in kg) at C. Point B is connected to a linear spring with spring constant k (in N/m) as shown in the figure. The length AB and AC are a and L, respectively. Neglecting the effect of gravity, the natural frequency of this spring-mass system in rad/s is

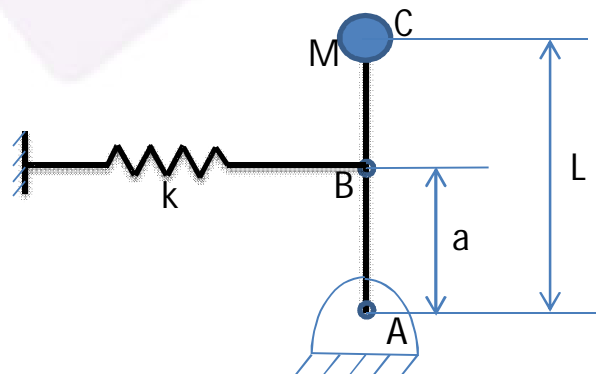

(A) $\sqrt{\frac{k L^2}{M a^2}}$

(B) $\sqrt{\frac{k a^2}{M L^2}}$

(C) $\sqrt{\frac{k L}{M a}}$

(D) $\sqrt{\frac{k a}{M L}}$

- Q.5 A two bar truss is shown in the Figure. The cross-sectional area and Young's modulus of bar 1 are 0.02 m^2 and 200 GPa , respectively. The cross-sectional area and Young's modulus of bar 2 are 0.01 m^2 and 80 GPa , respectively. The force F applied on the truss is 2 N . Find out the stress developed in bar 2 in Pa. _____

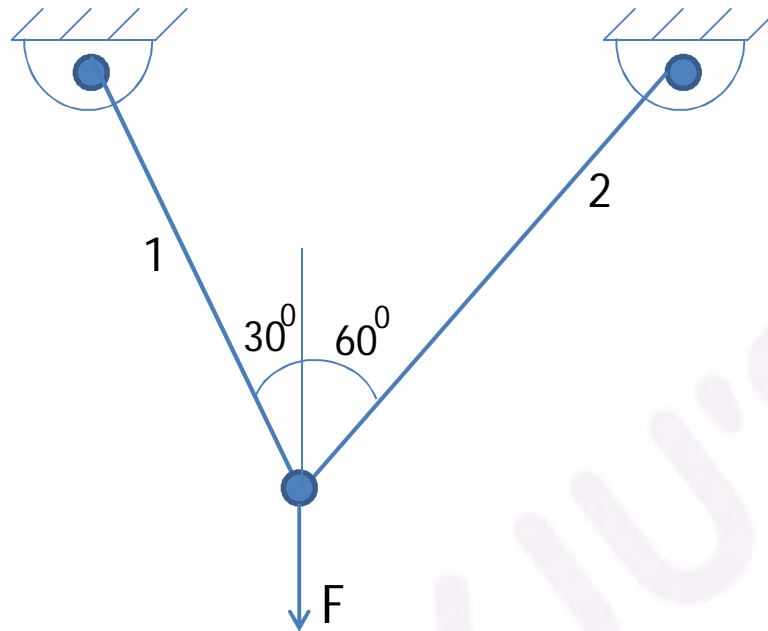

- Q.6 A spring balance reads 10 kg in a lift when the lift is stationary. When the lift starts moving with a constant acceleration, the new reading is 12.3 kg . If the upward acceleration is considered positive, what is the acceleration of the lift? Acceleration due to gravity may be taken as 10 m/s^2 downwards. _____
- Q.7 A force $F = 2 \text{ N}$ is applied on a block of mass $M = 0.5 \text{ kg}$ as shown in the figure. The block is constrained to move along the horizontal direction in a guideway. Find out the distance (in meters) travelled by the block in 2 s starting from rest. Neglect any friction between the block and the guideway. _____

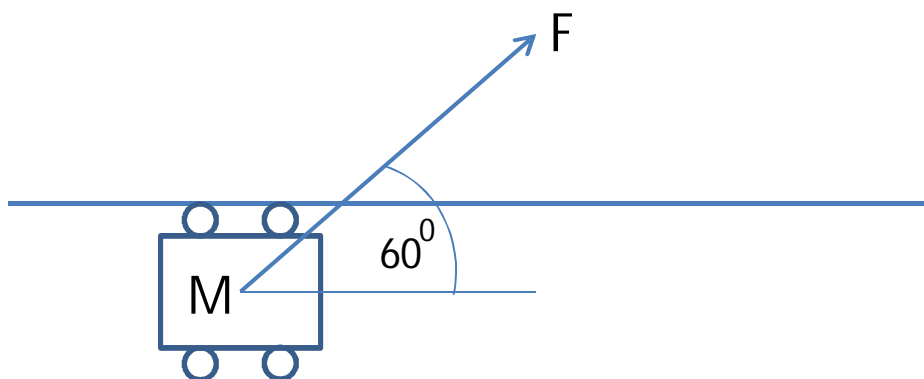

- Q.8 A man of mass 50 kg is walking on a long wooden board of mass 200 kg (as shown in the Figure). The wooden board is initially at rest on a frictionless ice surface. If the man walks with a velocity of $V = 1$ m/s in the positive x direction relative to the wooden board, find the velocity of the board in m/s. Velocity is positive in the positive x direction. _____

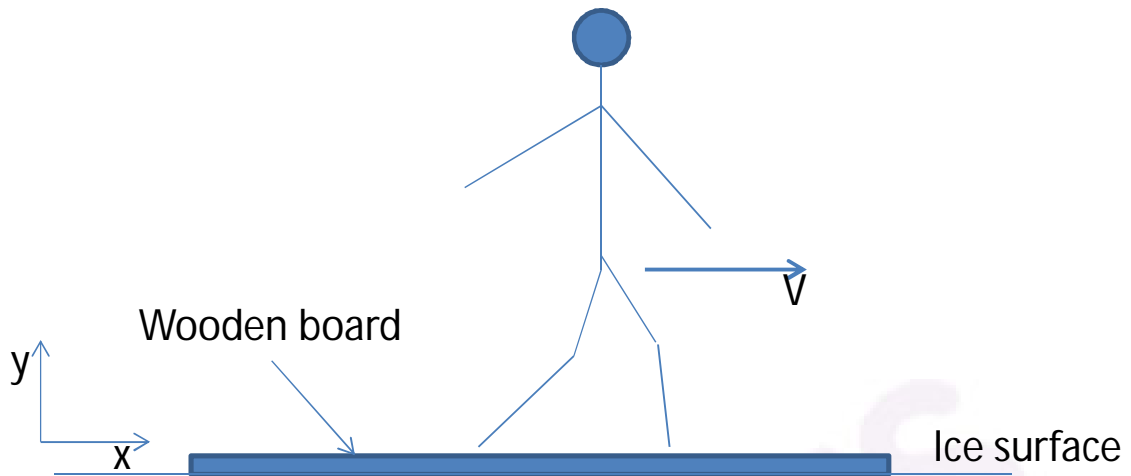

- Q.9 A rigid bar AB is hinged at B through a torsional spring with spring constant k_t . For small rotations of the bar AB about B, the critical load P_{cr} is given by

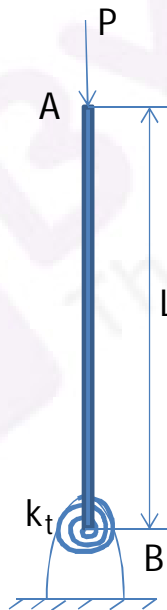

(A) $\frac{k_t}{2L}$

(B) $\frac{k_t}{L}$

(C) $\frac{2k_t}{L}$

(D) $\frac{4k_t}{L}$

Q. 10 - Q. 22 carry two marks each.

- Q.10 A disk of mass $M= 14\text{kg}$ and radius 1 m is attached to a spring which has a stiffness $k = 75\text{ N/m}$ and an unstretched length of 1m . If the disk is released from rest in the position shown in the Figure and the disk rolls without slipping, find its angular velocity (in rad/s) at the instant the center of mass is displaced by 3 m . _____

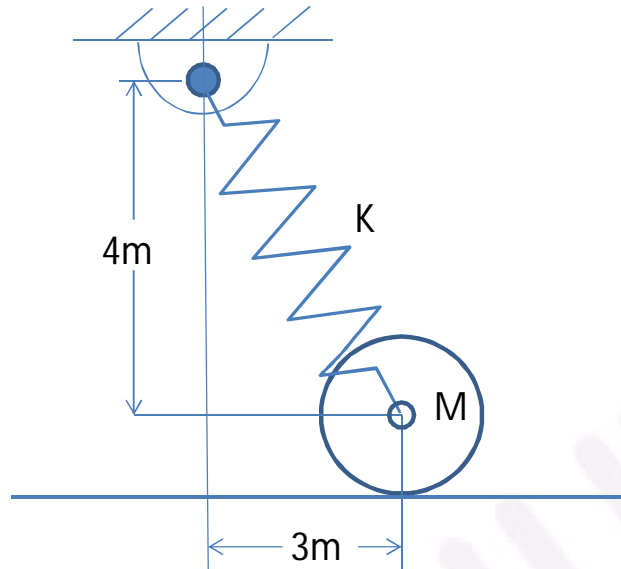

- Q.11 A strain gauge is mounted on the outer surface of a thin cylindrical pressure vessel in the circumferential direction. The mean diameter and thickness of the cylinder are 4.0 m and 20 mm , respectively. Young's modulus and Poisson's ratio of the material of the cylinder are 200 GPa and 0.25 , respectively. Find the pressure in MPa inside the cylindrical vessel when the strain gauge indicates a strain of 7.0×10^{-4} . _____
- Q.12 A solid shaft of diameter 100 mm is rotating at a constant angular speed of $(10/\pi)\text{ rad/s}$. The shaft carries three rigid pulleys A, B and C as shown in the Figure. Pulley B is connected to a motor supplying 10kW power. Pulley B and C are connected to two pumps consuming 5kW each. Find the maximum shear stress (in MPa) in the shaft due to torsion alone. _____

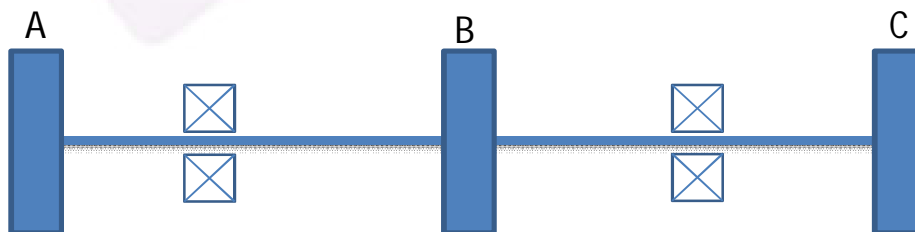

- Q.13 A beam is fixed at the left end and supported by a spring at the other end. The length of the beam is L and its flexural rigidity is EI . The spring constant of the spring is $k = \frac{3EI}{L^3}$. A vertical downward load P is applied at the right end. The deflection of the point under the load P is

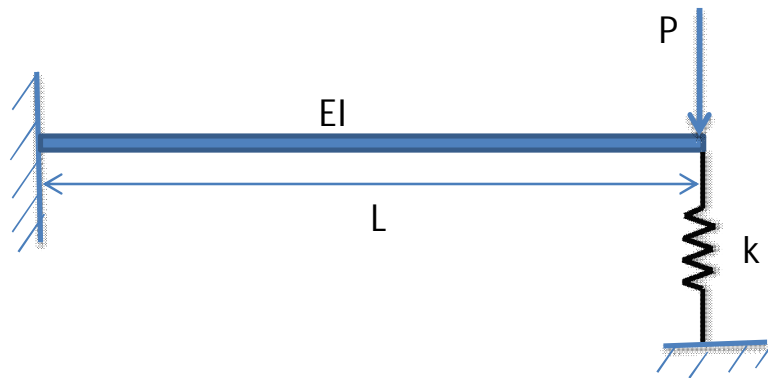

- (A) $\frac{P L^3}{9 EI}$ (B) $\frac{P L^3}{6 EI}$ (C) $\frac{2 P L^3}{9 EI}$ (D) $\frac{5 P L^3}{9 EI}$

- Q.14 Find the maximum bending moment (magnitude wise) in kN-m for the beam shown in the Figure.

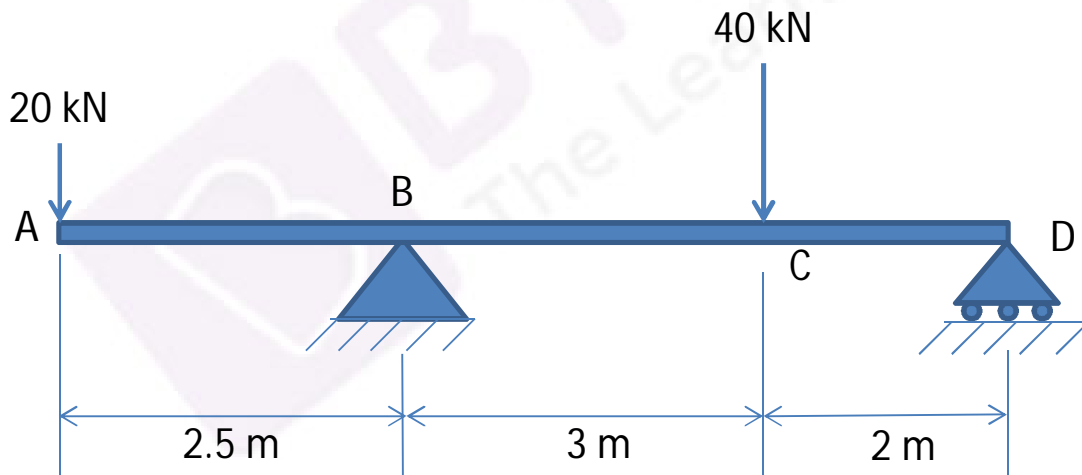

- Q.15 A projectile is fired with a velocity $V = 3\sqrt{2}$ m/s from a point at height $H = 0.8$ m at an angle of 45° with respect to the horizontal direction as shown in the Figure. Find the horizontal distance S in meters travelled by the projectile when it hits the ground. Take acceleration due to gravity as 10 m/s². _____

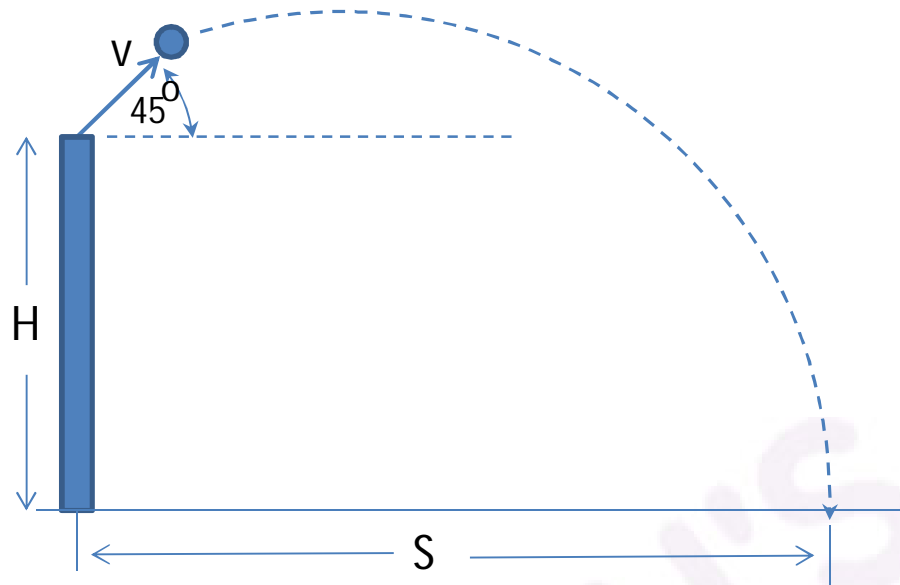

- Q.16 A particle P is moving on a circular path of radius $r = 1$ m. The angular location θ of the particle is measured as shown in the Figure. The motion of the particle is described by $\theta = 2 \sin(t)$. Find the magnitude of the total acceleration (in m/s²) of the particle at time $t = \pi/3$ seconds. _____

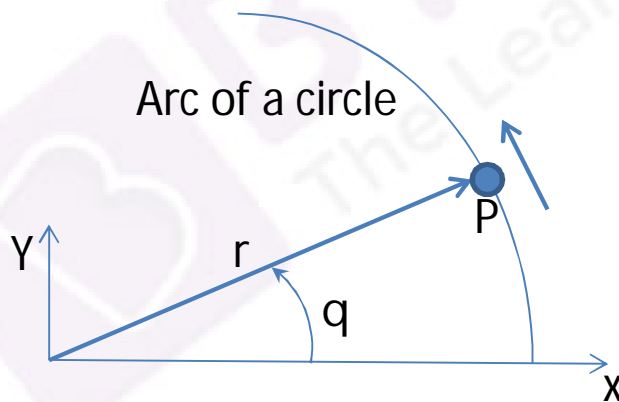

Common Data Questions

Common Data for Questions 17 and 18

A frame ABC is shown in the Figure. Members AB and BC both have a length of L , and Young's modulus E . Members AB and BC both have a square cross-section of side a . A load P is applied at point C as shown in the figure.

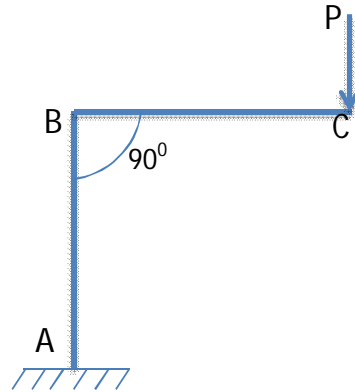

Q.17 Neglecting the axial compression of member AB, the deflection of point C in the direction of the load is

- (A) $\frac{2 P L^3}{E a^4}$ (B) $\frac{4 P L^3}{E a^4}$ (C) $\frac{8 P L^3}{E a^4}$ (D) $\frac{16 P L^3}{E a^4}$

Q.18 The maximum bending stress in the frame is

- (A) $\frac{3 P L}{a^3}$ (B) $\frac{6 P L}{a^3}$ (C) $\frac{9 P L}{a^3}$ (D) $\frac{12 P L}{a^3}$

Common Data for Questions 19 and 20

At a point in an object subjected to plane stress conditions, the state of stress is as shown in the Figure.

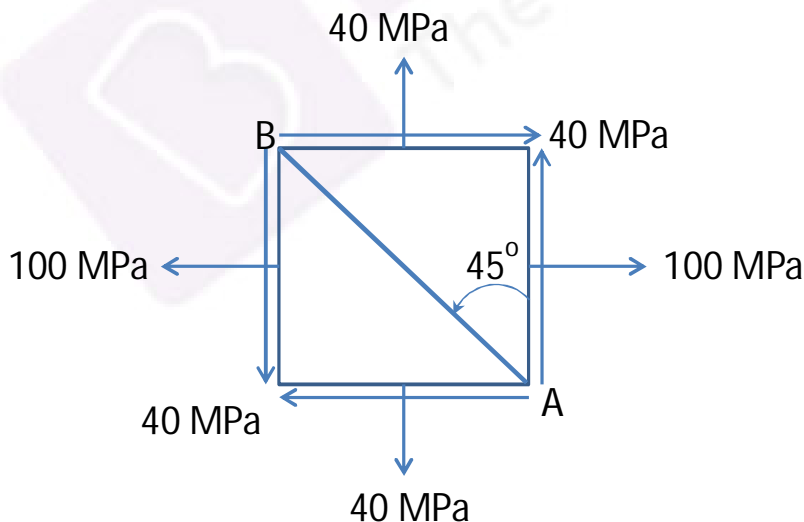

Q.19 One of the principal stresses (in MPa) is
 (A) 40 (B) 80 (C) 120 (D) 140

Q.20 The normal stress on the plane AB (in MPa) is
 (A) 30 (B) 70 (C) 100 (D) 110

Linked Answer Questions

Statement for linked answer questions 21 and 22

Two rods are joined together and the entire assembly is supported between two rigid walls, as shown in the Figure. The cross-sectional area and Young's modulus for both the rods are 0.01 m^2 and 10 GPa , respectively. The coefficients of thermal expansion for the two rods are $\alpha_1 = 4 \times 10^{-6} / ^\circ\text{C}$ and $\alpha_2 = 10^{-6} / ^\circ\text{C}$, respectively. The entire assembly is heated by 100°C . Neglect the effect of Poisson's ratio.

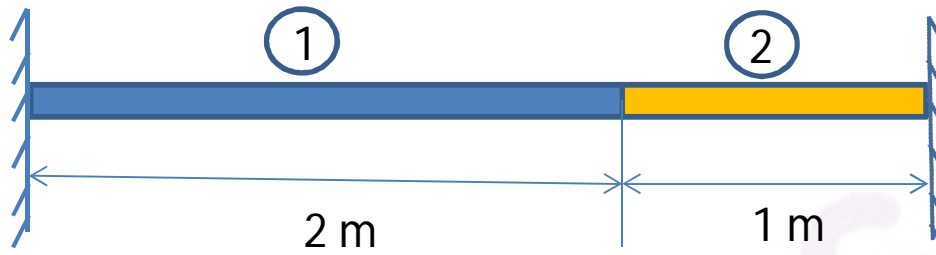

- Q.21 The stress in rod 1 (in MPa) is
- (A) -4.0 (B) -3.0 (C) -2.5 (D) -1.0
- Q.22 Considering the displacement to the right as positive, the displacement (in mm) of the interface between the two rods is
- (A) -0.2 (B) -0.1 (C) 0.1 (D) 0.2

END OF SECTION - D

E: THERMODYNAMICS

Notation used:

p -pressure, V - volume, T -temperature, S - entropy, H - enthalpy, U - internal energy G - Gibbs free energy.

Specific properties are designated by lower case symbols.

Useful data:

Universal gas constant (R)= 8.314 J/mol K

Acceleration due to gravity = 9.81 m/s²

Molecular masses in kg/kmol: $M_{air} = 29$, $M_{nitrogen}=28$, $M_{water}=18$, $M_{helium}=4$

Ratio of ideal gas specific heats $:\gamma_{ai}=1.4$

c_p for water = 4.186 kJ/kg K

Vapour pressure equation for water in the temperature range of 5 to 100 °C , with p in kPa and T in K

$$\ln(p) = 18.558 - \frac{5190}{T}$$

Q. 1 – Q. 9 carry one mark each.

- Q.1 The measured temperature of a system is 30°C. Its exact absolute temperature in K is
 (A) 303.00 (B) 303.10 (C) 303.15 (D) 303.16
- Q.2 The fuel air mixture in a petrol engine is ignited with a spark plug at the end of compression stroke. This process
 (A) increases the entropy of the fuel air mixture but decreases the entropy of the spark plug
 (B) decreases the entropy of the fuel air mixture but increases the entropy of the spark plug
 (C) decreases the entropy of the fuel air mixture and of the spark plug
 (D) increases the entropy of the fuel air mixture and of the spark plug
- Q.3 In the van der Waals equation of state given below:

$$\left(p + \frac{a}{v^2}\right)(v - b) = RT$$
 The constant a represents the effect of
 (A) attractive forces between molecules
 (B) repulsive forces between molecules
 (C) deviation from molecules being spherical
 (D) finite size of the molecule
- Q.4 For a reversible isothermal expansion of an ideal gas from a state 1 to a state 2,
 (A) $s_1 = s_2$ (B) $s_1 > s_2$ (C) $s_1 < s_2$ (D) $h_1 > h_2$
- Q.5 For a pure substance the critical isotherm on the p - v plane exhibits
 (A) a maximum (B) a minimum
 (C) a point of inflection (D) a discontinuity
- Q.6 For an ideal gas as a working fluid for a given heat input Q , the process that gives the maximum work among the following four processes is
 (A) isothermal (B) constant volume (C) constant pressure (D) isentropic

Q.7 An air standard Otto cycle has the following shape on a thermodynamic property plane.

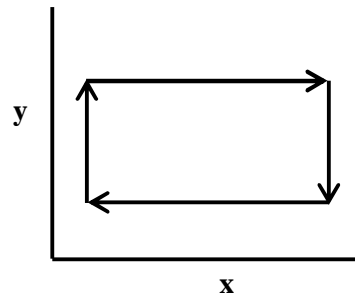

The x and y coordinates, respectively, are

- (A) v and p (B) s and v (C) v and T (D) s and p

Q.8 The specific volume of steam after expansion in a turbine is $12 \text{ m}^3/\text{kg}$. At this pressure the saturated liquid and saturated vapour specific volumes are 0.001 and $15.25 \text{ m}^3/\text{kg}$ respectively. What is the dryness fraction to second decimal place accuracy? _____

Q.9 Which of the following processes, shown in the figure below, represents the throttling of an ideal gas?

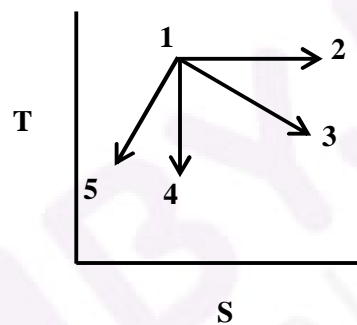

- (A) 1to2 (B) 1to 3 (C) 1to 4 (D) 1to 5

Q. 10 - Q. 22 carry two marks each.

Q.10 On a $\ln pvsh$ coordinate system, where $\ln p$ is the y -coordinate and h is the x coordinate, the slope of a constant entropy line is

- (A) $1/v$ (B) v (C) p/v (D) $1/(pv)$

Q.11 Starting from the definition of Gibbs free energy function $g=h-Ts$, the Maxwell relation that can be derived is

- (A) $\left. \frac{\partial p}{\partial T} \right|_s = \frac{v}{s}$ (B) $\left. \frac{\partial p}{\partial T} \right|_s = v$ (C) $\left. \frac{\partial v}{\partial s} \right|_T = -\left. \frac{\partial p}{\partial T} \right|_s$ (D) $\left. \frac{\partial v}{\partial T} \right|_p = -\left. \frac{\partial s}{\partial p} \right|_T$

- Q.12 A thermodynamic cycle operates between one source at a temperature of 600 K, another source at a temperature of 300 K and a sink at a temperature T as shown in the figure below

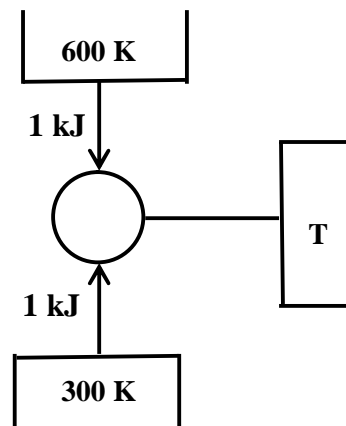

If the First and Second laws of thermodynamics are not violated, what should be the value of T in K? _____

- Q.13 A closed system containing an ideal gas undergoes a cycle as shown in the figure shown below. For the process 1-2, which one of the following statements is true?

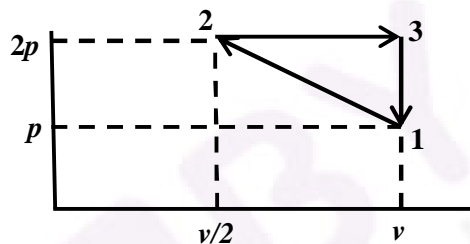

- (A) Heat added = $\frac{3}{4}pv$ (B) Heat rejected = $\frac{3}{4}pv$
 (C) Heat added = $\frac{1}{2}pv$ (D) Heat rejected = $\frac{1}{4}pv$

- Q.14 A well-insulated rigid hot water tank receives steady flow of water from two sources as shown in the figure below

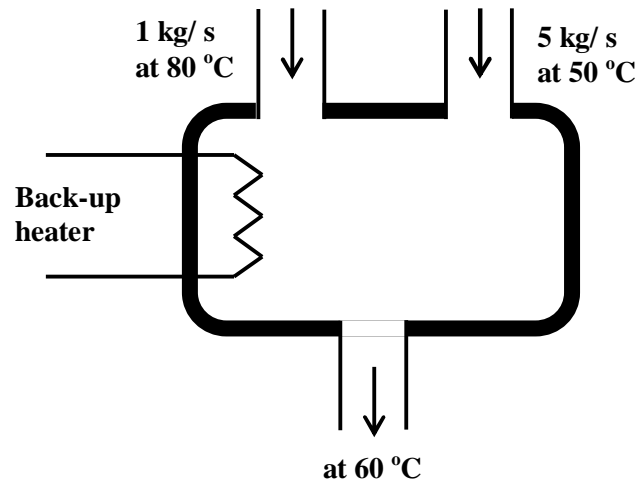

There is no accumulation of water in the tank. A back-up heater is provided to ensure a constant outflow temperature of water at 60 °C from the tank under steady state. What is the required capacity of the back-up heater to the nearest kW? _____

- Q.15 1 kg of air in an insulated rigid tank of volume 1 m³ is churned with a friction-less fan (see figure below) of 600 W capacity for 10 minutes. The fan efficiency is 100 %. Treating air as an ideal gas and neglecting kinetic and potential energy changes, what is the increase of pressure, to the nearest kPa? _____

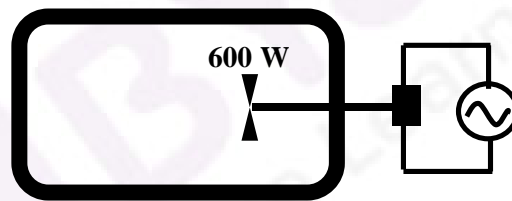

- Q.16 The isothermal compressibility of a liquid is 5×10^{-6} /kPa. If it is compressed at constant temperature from 5000 to 10000kPa, what is the ratio of final volume to initial volume, to second decimal place accuracy? _____

Common Data Questions

Common Data for Questions 17 and 18:

At a location where the atmospheric pressure is 98 kPa and the ambient temperature is 30°C, the humidity ratio is 0.01 kg/kg of dry air. A high pressure front moves over the location which changes only the atmospheric pressure to 102kPa, while the humidity ratio remains same.

- Q.17 What is the partial pressure of water vapour in kPa to the first decimal place accuracy before the high pressure front moves in? _____
- Q.18 What is the relative humidity of air under the influence of high pressure front to integer precision in %? _____

Common Data for Questions 19 and 20:

A rigid insulated cylinder is divided into two chambers A and B by a thin rigid insulating barrier as shown in the figure below

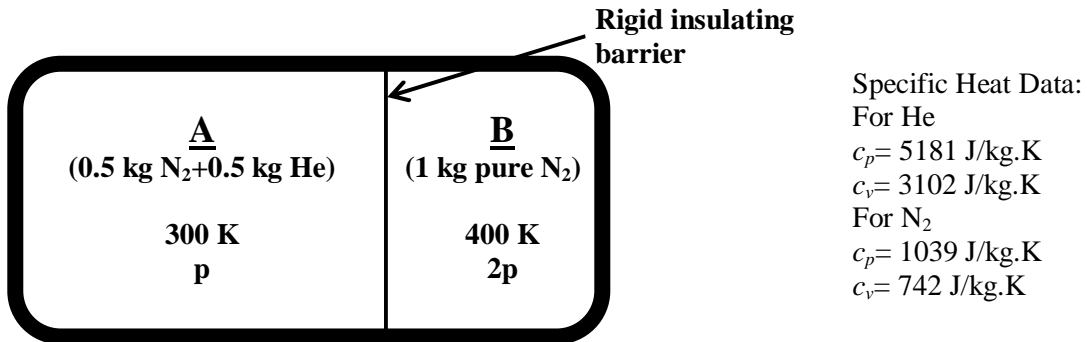

Initially, chamber A contains a mixture of 0.5 kg nitrogen and 0.5 kg helium at 300 K while chamber B contains 1 kg of pure nitrogen at 400 K. The pressure in chamber B is twice that in chamber A. The gases and gas mixtures are assumed to be ideal.

- Q.19 What is the ratio of the volumes of chambers A and B, i.e. V_A/V_B , to first decimal place accuracy?

- Q.20 If the barrier is removed and the gases are allowed to mix and reach thermodynamic equilibrium, what is the final temperature of the mixture, to the nearest K? _____

Linked Answer Questions

Statement for Linked Answer Questions 21 and 22:

A combined vapour compression-cum-Brayton cycle is shown below

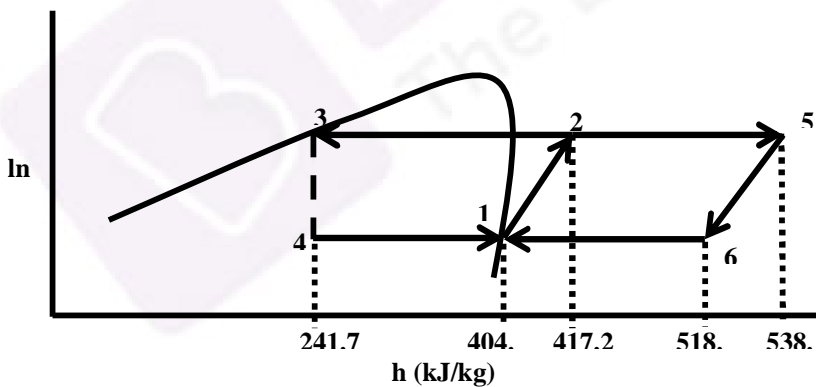

1-2: Isentropic compression, 5-6: isentropic expansion.

The refrigeration system has a cooling capacity of 30 kW and the turbine generates a power of 30 kW.

- Q.21 What is the mass flow rate of the working fluid through the turbine, in kg/s, to first decimal place accuracy? _____

- Q.22 What is the power required to drive the compressor, to the nearest kW? _____

END OF SECTION - E

F: POLYMER SCIENCE AND ENGINEERING**Q. 1 – Q. 9 carry one mark each.**

- Q.1 In free radical polymerization, one of the following techniques permits simultaneous increase in rate of polymerization and polymer molecular weight.
- (A) Solution polymerization.
(B) Suspension polymerization.
(C) Bulk polymerization.
(D) Emulsion polymerization.
- Q.2 The shear modulus, G , of plastic is related to the elastic modulus, E , and the Poisson ratio, ν , as
- (A) $E = 2(1 - \nu)G$ (B) $G = 2(1 + \nu)E$
(C) $E = 2(1 + \nu)G$ (D) $E = (1 + \nu)G$
- Q.3 LLDPE is obtained by
- (A) Ziegler-Natta polymerization of ethylene.
(B) free-Radical polymerization of ethylene.
(C) free-Radical polymerization of ethylene and alpha-olefins.
(D) Ziegler-Natta copolymerization of ethylene and alpha-olefins.
- Q.4 A hindered phenol is added to a polyolefin
- (A) to increase ozone resistance (B) to increase foamability
(C) to increase oxidation resistance (D) to increase crosslinkability
- Q.5 Stretching of rubber leads to
- (A) decrease in alignment of polymer chains
(B) increase in alignment of polymer chains
(C) no change in alignment of polymer chains
(D) decrease in strength of rubber
- Q.6 In a cone and plate viscometer, the rate of strain is related to the speed of rotation of the cone, ω (radian/second), and the angle between the cone and the plate, α (radian), by the following relation
- (A) $\omega\alpha$ (B) $\omega\cos\alpha$ (C) $\frac{\alpha}{\omega}$ (D) $\frac{\omega}{\alpha}$
- Q.7 The tensile breaking strength of polycarbonate (I), low density polyethylene (II), polystyrene (III) and polypropylene (IV) can be arranged as
- (A) $IV > II > I > III$ (B) $I > II > IV > III$ (C) $I > III > IV > II$ (D) $III > I > II > IV$
- Q.8 High molecular weight polymers could be obtained even at low monomer conversion in case of
- (A) Step growth polymerization (B) Living polymerization
(C) Chain growth polymerization (D) Solid state polymerization
- Q.9 A reinforced polymer composite is made by the incorporation of
- (A) elastomers into the polymer.
(B) fibers into the polymer.
(C) plasticizers into the polymer.
(D) gaseous additives into the polymer.

Q. 10 - Q. 22 carry two marks each.

- Q.10 Match the following for free-radical copolymerization of two monomers with reactivity ratios, r_1 and r_2 .

Reactivity Ratios

- P. $r_1 = r_2 = 0$
 Q. $r_1 = r_2 = 1$
 R. $r_1 > 1, r_2 > 1$
 S. $0 < r_1 r_2 < 1$

Copolymer Nature

1. Random copolymer
 2. Alternate copolymer
 3. Block copolymer
 4. Random-Block copolymer

- (A) P-2; Q-1; R-3; S-4
 (B) P-3; Q-1; R-2; S-4
 (C) P-2; Q-4; R-3; S-1
 (D) P-2; Q-3; R-1; S-4

- Q.11 The relative viscosity of a 1% solution (weight/volume) of a given polymer was found to be 1.1. The inherent viscosity of this polymer will be

- (A) 0.065 dl/g (B) 0.075 dl/g (C) 0.085 dl/g (D) 0.095 dl/g

- Q.12 Match the following in case of step-growth polymerization, where A reacts only with B, and B reacts only with A (Note: A—A is expressed as A_2 , and $A \begin{array}{l} \diagup B \\ \diagdown B \end{array}$ is expressed as AB_2).

Monomers

- P. $A_2 + AB_3$
 Q. AB_2
 R. $AB + B_3$
 S. $A_2 + B_2$

Polymer

1. Hyperbranched Polymer
 2. Crosslinked Polymer
 3. Star Polymer
 4. Linear Polymer

- (A) P-2; Q-3; R-1; S-4
 (B) P-2; Q-1; R-3; S-4
 (C) P-1; Q-2; R-3; S-4
 (D) P-2; Q-4; R-1; S-3

- Q.13 Match each of the following additives for plastics with its function

Additive

- P. α -Cellulose
 Q. Zinc chromate
 R. Alumina trihydrate
 S. Chlorinated paraffin wax

Function

1. Flame retarder
 2. Plasticizer extender
 3. Organic fibrous filler
 4. Colorant

- (A) P-1; Q-2; R-3; S-4
 (B) P-2; Q-3; R-4; S-1
 (C) P-3; Q-4; R-1; S-2
 (D) P-4; Q-1; R-2; S-3

- Q.14 The length of a glass fiber reinforced polymer increased by 0.03mm, from its initial length of 100mm, when the temperature was changed from -30°C to $+30^\circ\text{C}$. The coefficient of linear thermal expansion is

- (A) $1.03 \times 10^{-5} \text{ }^\circ\text{C}^{-1}$ (B) $9.82 \times 10^{-6} \text{ }^\circ\text{C}^{-1}$ (C) $5.00 \times 10^{-6} \text{ }^\circ\text{C}^{-1}$ (D) $14.4 \times 10^{-5} \text{ }^\circ\text{C}^{-1}$

- Q.15 A 40mm x 40mm square polymer composite sample with 5mm thickness (heat transfer distance) exhibited a heat flow rate of 60W, when the temperatures of the warm and cold surfaces were 90°C and 25°C respectively. The thermal conductivity of the sample in $\text{W}\cdot\text{m}^{-1}\cdot\text{K}^{-1}$ is

- (A) 5.67 (B) 15.3 (C) 2.88 (D) 0.667

- Q.16 An extruder is supplied with 40 kW of power. The mass flow rate of a polymer through the extruder is 240 kg h^{-1} and the specific heat capacity of the polymer is $4 \text{ kJ kg}^{-1} \text{ K}^{-1}$. The maximum possible temperature rise in the polymer is

- (A) 150 K (B) 100 K (C) 600 K (D) Zero

Common Data Questions

Common Data for Questions 17 and 18:

For a given free-radical polymerization, the only mode of termination is the bimolecular termination and there is no chain transfer. The final polymer produced was analyzed to contain an average of 1.60 initiator fragments per polymer chain.

- Q.17 Percentage of final polymer chains containing one initiator fragment per chain is
 (A) 40 % (B) 50 % (C) 60 % (D) 70 %
- Q.18 Percentage of polymer radicals terminated by coupling is
 (A) 65 % (B) 75 % (C) 85 % (D) 95 %

Common Data for Questions 19 and 20:

For the synthesis of polyester, 1.5 mole of pentaerythritol (tetra-ol) was reacted with 1.0 mole of a tricarboxylic acid.

- Q.19 The extent of reaction when the number average degree of polymerization of the reaction mixture approaches infinity is
 (A) 80.33% (B) 83.33% (C) 84.33% (D) 86.33%
- Q.20 The number average degree of polymerization of the reaction mixture when the polymerization was stopped at 80% conversion, is
 (A) 1000 (B) 100 (C) 50 (D) 25

Linked Answer Questions

Statement for Linked Answer Questions 21 and 22:

A viscoelastic fluid is modeled as a spring and two dashpots, all connected in series. The spring has elastic modulus G and the fluids in two dashpots have viscosities η_1 and η_2 .

- Q.21 The constitutive equation (relation between stress σ and strain γ in which overdot represents the time derivative) for the fluid is:
 (A) $\sigma = G\gamma + (\eta_1 + \eta_2)\dot{\gamma}$ (B) $\sigma = G\gamma + (\eta_1 - \eta_2)\dot{\gamma}$
 (C) $\dot{\gamma} = \frac{\dot{\sigma}}{G} + \left(\frac{1}{\eta_1} + \frac{1}{\eta_2}\right)\sigma$ (D) $\dot{\gamma} = \frac{\dot{\sigma}}{G} + \frac{\sigma}{\eta_1 + \eta_2}$
- Q.22 For a periodic stress $\sigma = \sigma_0 e^{i\omega t}$, the strain is given by
 (A) $\gamma = \sigma_0 \left[\frac{1}{G} + \frac{i}{\omega} \left(\frac{1}{\eta_1} + \frac{1}{\eta_2} \right) \right] e^{i\omega t}$ (B) $\gamma = \sigma_0 \left[\frac{1}{G} - \frac{i}{\omega} \left(\frac{1}{\eta_1} + \frac{1}{\eta_2} \right) \right] e^{i\omega t}$
 (C) $\gamma = [\sigma_0 + (\eta_1 + \eta_2)\omega i] \frac{e^{i\omega t}}{G}$ (D) $\gamma = [\sigma_0 - (\eta_1 + \eta_2)\omega i] \frac{e^{i\omega t}}{G}$

END OF SECTION - F

G:FOOD TECHNOLOGY**Q. 1 – Q. 9 carry one mark each.**

- Q.1 Kawashiorkor disease is caused due to the deficiency of
- (A) lysine (B) unsaturated fatty acids
(C) vitamin K (D) protein
- Q.2 Which of the following statements is TRUE in case of oxidative rancidity of vegetable oils and fats?
- (A) It is caused by the reaction of saturated fatty acids and oxygen
(B) It involves polymerization of fatty acids
(C) It is caused by the reaction of unsaturated fatty acids with oxygen
(D) It is caused by oxidative enzymes
- Q.3 The food borne disease, Q fever is caused by the organism,
- (A) *Clostridium perfringens* (B) *Coxiella burnetti*
(C) *Bacillus cereus* (D) *Staphylococcus aureus*
- Q.4 The primary bacterial spoilage of poultry meat at low temperature, with characteristic sliminess at outer surface, is caused by
- (A) *Pseudomonas spp.* (B) *Aspergillus spp.*
(C) *Bacillus spp.* (D) *Candida spp.*
- Q.5 The weight gain (in gram) per gram protein consumed is called
- (A) Net Protein Ratio (NPR) (B) Biological Value (BV)
(C) Protein Efficiency Ratio (PER) (D) Chemical Score (CS)
- Q.6 Which of the following carbohydrates is NOT classified as dietary fibre?
- (A) Agar (B) Pectin
(C) Sodium alginate (D) Tapioca starch
- Q.7 In the extruder barrel, the compression is achieved by back pressure created by the die and by
- (A) increasing pitch and decreasing diameter of the screw
(B) using the tapered barrel with constant pitch
(C) increase in the clearance between barrel surface and screw
(D) opening of the die
- Q.8 The brown colour of bread crust during baking is due to Maillard reaction between
- (A) aldehyde groups of sugars and amino groups of proteins
(B) aldehyde groups of sugars and vitamins
(C) aldehyde groups of sugars and salt
(D) starch and yeast
- Q.9 Blanching influences vegetable tissues in terms of
- (A) enzymes production
(B) alteration of cytoplasmic membrane
(C) stabilization of cytoplasmic proteins
(D) stabilization of nuclear proteins

Q. 10 - Q. 22 carry two marks each.

Q.10 Match the toxicants of plant foods in **Group I** with their main plant source given in **Group II**.

Group I

P) Gossypol

Q) Vicine

R) Glucosinolates

S) BOAA (beta-N- Oxalyl Amino L-Alanine)

Group II1) Khesari Dahl (*Lathyrus sativus*)

2) Cotton seeds

3) Fava beans

4) Rapeseeds

(A) P-2, Q-3, R-4, S-1

(B) P-2, Q-4, R-3, S-1

(C) P-3, Q-1, R-2, S-4

(D) P-4, Q-3, R-1, S-2

Q.11 Match the products in **Group I** with the enzymes used for their preparation given in **Group II**.

Group I

P) Aspartame

Q) Cocoa butter substitute

R) High fructose corn syrup

S) Lactose free milk

Group II

1) Lipase

2) Glucose isomerase

3) Thermolysin

4) Invertase

5) Beta galactosidase

(A) P-2, Q-1, R-4, S-3

(B) P-3, Q-1, R-2, S-5

(C) P-1, Q-3, R-2, S-4

(D) P-1, Q-2, R-4, S-5

Q.12 Match the food items in **Group I** with the type of colloidal dispersion given in **Group II**.

Group I

P) Mayonnaise

Q) Tomato ketchup

R) Cake

S) Curd

Group II

1) Sol

2) Emulsion

3) Gel

4) Solid foam

(A) P-4, Q-1, R-2, S-3

(B) P-3, Q-1, R-2, S-4

(C) P-2, Q-3, R-4, S-1

(D) P-2, Q-1, R-4, S-3

Q.13 [a] **Assertion:** In the presence of sucrose, the temperature and time for gelatinization of starch increases .

[r] **Reason:** Sucrose, due to its hygroscopic nature, competes with starch for water needed for gelatinization.

(A) Both [a] and [r] are true and [r] is the correct reason for [a]

(B) Both [a] and [r] are true but [r] is not the correct reason for [a]

(C) Both [a] and [r] are false

(D) [a] is true but [r] is false

Q.14 Thermal death of viable spores of *Bacillus subtilis* in a food sample follows a first order kinetics with a specific death rate constant of 0.23 min^{-1} at 100°C . The time (in minutes) required to kill 99% of spores in the food sample at 100°C will be

(A) 10

(B) 20

(C) 23

(D) 60

Q.15 How much skim milk (in kg) containing 0.1% fat should be added to 500 kg of cream containing 50% fat to produce standardized cream containing 36% fat?.

(A) 140

(B) 165

(C) 195

(D) 210

Q.16 Which of the following statements is NOT CORRECT in relation to muscle proteins ?

(A) Actin and myosin interact to form actomyosin which is responsible for muscle contraction

(B) Collagen contributes to the toughness of muscles due to its abundant presence

(C) Elastin, a constituent of ligaments, is tougher than collagen

(D) Actomyosin is not the main state of actin and myosin in post-mortem muscles

Common Data Questions

Common Data for Questions 17 and 18: A cold storage plant is used for storing 50 tonnes of apples in perforated plastic crates. During the storage, apples are cooled down from 28°C to storage temperature of 2°C. (Specific heat of the apple = 0.874 kCal kg⁻¹ °C⁻¹)

Q.17 If the required cooling is attained in 16 hours, the refrigeration plant capacity (in Tons) is

- (A) 19 (B) 24 (C) 29 (D) 32

Q.18 If the cooling is to be achieved in 8 hours, the power required (in Horse Power) to operate the plant having a Coefficient of Performance (COP) of 2.5 will be

- (A) 47 (B) 65 (C) 89 (D) 96

Common Data for Questions 19 and 20: An actively growing culture of *Acetobacter aceti* is added to the vigorously aerated fermented fruit juice medium containing 10 g l⁻¹ ethanol to produce vinegar. After some time, the ethanol concentration in the medium is 0.8 g l⁻¹ and acetic acid produced is 8.4 g l⁻¹.

Q.19 What is the conversion efficiency of the process with respect to theoretical yield?

- (A) 30 (B) 50 (C) 70 (D) 90

Q.20 The concentration of fermentable sugars (g l⁻¹) required in the fruit juice to produce 10 g l⁻¹ ethanol, based on 90% fermentation efficiency is

- (A) 20.0 (B) 21.7 (C) 22.8 (D) 25.1

Linked Answer Questions

Statement for Linked Answer Questions 21 and 22: An enzyme catalyzed reaction (following Michaelis-Menten kinetics) exhibits maximum reaction velocity (V_m) of 75 nmol l⁻¹ min⁻¹. The enzyme at a substrate concentration of 1.0x10⁻⁴ M shows the initial reaction velocity of 60 nmol l⁻¹min⁻¹.

Q.21 The K_m value of the enzyme in molar concentration (M) is

- (A) 2.5 x 10⁻⁵ (B) 5.0 x 10⁻⁵
(C) 2.5 x 10⁻⁴ (D) 5.0 x 10⁻⁴

Q.22 If the enzyme concentration for the reaction is doubled at a substrate concentration of 5.0 x 10⁻⁵ M, the initial reaction velocity in nmol l⁻¹ min⁻¹ will be

- (A) 37.5 (B) 50 (C) 60 (D) 100

END OF THE QUESTION PAPER