

Regd. Office : Aakash Tower, 8, Pusa Road, New Delhi-110005, Ph.011-47623456

JEE Mains Paper-2022

PHYSICS

1. Referring to the diagram

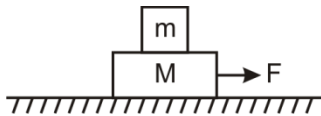

friction is present everywhere friction coefficient $\mu = 0.5$, $m = 2$ kg and $M = 8$ kg. The maximum value of F for which both of the block moves together.

- (1) 50 N (2) 100 N
(3) 150 N (4) 200 N

Sol. Answer (2)

As both the block move together

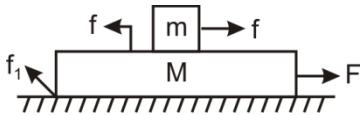

$$F - \mu(M+m)g = (M+m)a$$

$$a = \frac{F}{M+m} - \mu g$$

For upper block

$$f = ma$$

$$f = \frac{mF}{M+m} - \mu mg$$

$$f \leq \mu mg$$

$$\frac{mF}{M+m} \leq 2\mu mg$$

$$F \leq 2\mu(M+m)g$$

$$F_{\max} = 100\text{N}$$

2. Two columns are given below. Column 1 gives a range of electromagnetic spectrum while column 2 gives possible wave. Match column 1 with column 2.

Column -1

(P) UV

(Q) Microwaves

(R) Infra red

(S) X-rays

(1) P-C, Q-D, R-B, S-A

(2) P-A, Q-B, R-C, S-D

(3) P-D, Q-B, R-C, S-A

(4) P-C, Q-D, R-A, S-D

Column -2

(A) Study of crystal structure

(B) Greenhouse effect

(C) Sterilizing surgical instruments

(D) Radio signals

Sol. Answer (1)

- UV rays are used to sterilize surgical instruments
- Microwaves are used in Radio communication
- Infrared waves are sources of green house effect
- x-ray is used to study crystal structure.

3. Measurements of a wire yields the following results:

$$\text{Mass} = 0.6 \pm 0.006 \text{ g}$$

$$\text{Radius} = 0.5 \pm 0.005 \text{ mm}$$

$$\text{Length} = 4 \pm 0.04 \text{ cm}$$

Find the maximum % error in density of the wire.

- (1) 2 % (2) 3 %
(3) 4 % (4) 5 %

Sol. Answer (3)

$$\rho = \frac{M}{\pi r^2 L}$$

$$\left(\frac{\Delta\rho}{\rho}\right) \times 100 = \pm \left[\frac{\Delta M}{M} + 2\frac{\Delta r}{r} + \frac{\Delta L}{L} \right] \times 100$$

$$= \pm \left[\frac{0.006}{0.6} + 2 \times \frac{0.005}{0.5} + \frac{0.04}{4} \right] \times 100$$

$$= \pm 4\%$$

4. Two blocks 10 kg and 30 kg lies on x-axis at (0,0) and (x, 0) respectively. The block 10 kg is moved on the same line 6cm towards the other block. What distance should the other block move to keep the centre of mass of system unchanged

- (1) 3 cm away from 10 kg block
- (2) 3 cm towards 10 kg block
- (3) 2 cm away from 10 kg block
- (4) 2 cm towards 10 kg block

Sol. Answer (4)

We know,

$$\Delta x_{cm} = \frac{m_1 \Delta x_1 + m_2 \Delta x_2}{m_1 + m_2}$$

where $\Delta x_1 =$ shift of m_1 , $\Delta x_2 =$ shift of m_2

and $\Delta x_{cm} =$ shift of centre of mass of system

Given $\Delta x_1 = 6\text{cm}$ and $\Delta x_{cm} = 0$

$$10 \times 6 + 30 \times \Delta x_2 = 0$$

$$\therefore \Delta x_2 = -2\text{cm}$$

5. In an experiment of potentiometer if $R = 8\Omega$ then null point AC is equal to 3m and when $R = 4\Omega$ then $AC = 2\text{m}$. Then value of internal resistance r is

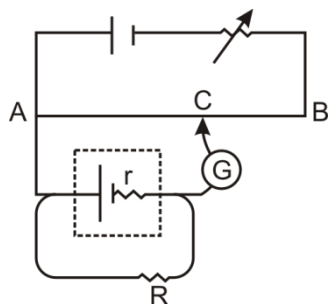

- (1) 3Ω
- (2) 4Ω
- (3) 6Ω
- (4) 8Ω

Sol. Answer (3)

$L_1 =$ balancing length when external resistor R is not connected across secondary cell.

$L_2 =$ balancing length when external resistor R is connected across secondary all.

$$r = R \left[\frac{L_1}{L_2} - 1 \right]$$

$$r = 8 \left[\frac{L_1}{3} - 1 \right] \quad \rightarrow (1)$$

$$r = 4 \left[\frac{L_1}{2} - 1 \right] \quad \rightarrow (2)$$

$$1 = \frac{2 \left[\frac{L_1}{3} - 1 \right]}{\left[\frac{L_1}{2} - 1 \right]} \quad \text{divide (1) and (2)}$$

$$L_1 = 6\text{m}$$

$$r = 8 \left[\frac{6}{3} - 1 \right] \quad \therefore r = 8$$

6. A projectile is projected (from the top of a tower) with velocity 20 m/s at an angle α with the horizontal. After 10 s, the inclination of velocity with the horizontal becomes β . Then the value of $\tan \alpha - \tan \beta$ is (use $g = 10 \text{ m/s}^2$)

- (1) $5 \cos \alpha$
- (2) $5 \sec \alpha$
- (3) $6 \sin \alpha$
- (4) $4 \cot \alpha$

Sol. Answer (2)

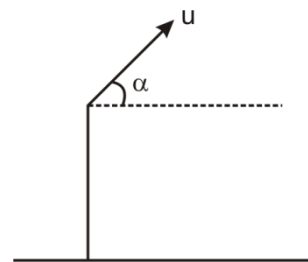

$$u_x = u \cos \alpha$$

$$u_y = u \sin \alpha$$

$$v_x = u_x = u \cos \alpha$$

$$v_y = u_y - gt$$

$$v_y = u \sin \alpha - gt$$

$$\tan \beta = \frac{v_y}{v_x} = \frac{u \sin \alpha - gt}{u \cos \alpha}$$

$$\tan\beta = \tan\alpha - \frac{gt}{u\cos\alpha}$$

$$\tan\alpha - \tan\beta = \frac{gt}{u}\sec\alpha = \frac{100}{20}\sec\alpha = 5\sec\alpha$$

7. A girl holds an umbrella at an angle of 45° against the rain. Suddenly she starts running at a speed of 25 m/sec. Now rain is falling vertically towards the girl. Then find the velocity of rain.

- (1) 30 m/sec (2) $25\sqrt{2}$ m/sec
 (3) 50 m/sec (4) $\frac{25}{\sqrt{2}}$ m/sec

Sol. Answer (2)

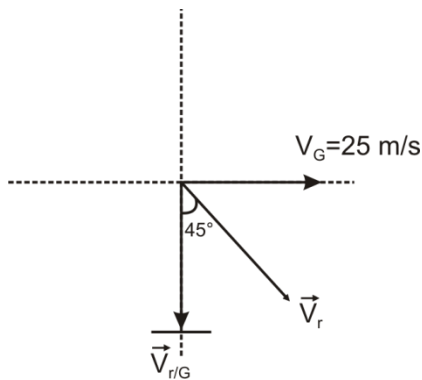

$$\vec{V}_{r/G} = \vec{V}_r + (-\vec{V}_G)$$

$$\vec{V}_r = \vec{V}_{r/G} + \vec{V}_G$$

$$\tan\theta = \frac{V_G}{V_{r/G}}$$

$$\tan\theta = 1$$

$$V_G = V_{r/G}$$

$$V_r = \sqrt{(V_{r/G})^2 + (V_G)^2}$$

$$= 25\sqrt{2} \text{ m/s}$$

8. A capacitor of capacitance C is connected to a source of voltage V . After long time it is disconnected and then connected to a capacitor of uncharged capacitor of same capacitance. The loss of energy in this process, after connecting with the capacitor is

- (1) $\frac{1}{2}CV^2$ (2) $\frac{1}{8}CV^2$
 (3) $\frac{1}{4}CV^2$ (4) CV^2

Sol. Answer (3)

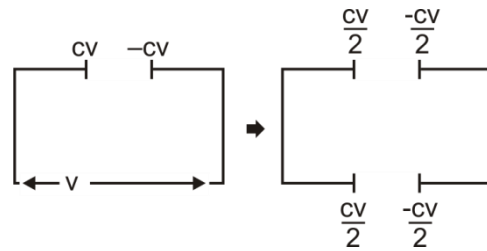

$$U_i = \frac{1}{2}CV^2$$

$$U_f = \frac{1}{2}C\left(\frac{V}{2}\right)^2 + \frac{1}{2}C\left(\frac{V}{2}\right)^2$$

$$U_f = \frac{1}{4}CV^2$$

$$\text{Loss of energy} = U_i - U_f = \frac{1}{4}CV^2$$

9. An α particle and C^{12} atom has same kinetic energy. Find the ratio of de-Broglie wavelength of α particle to that of C^{12} atom.

- (1) $\sqrt{2}$ (2) $\sqrt{3}$
 (3) $\sqrt{5}$ (4) $\sqrt{6}$

Sol. Answer (2)

Let $m_\alpha = 4 \text{ amu}$ and $m_c = 12 \text{ amu}$

Given $K_\alpha = K_c$

$$\text{We know, } \lambda = \frac{h}{\sqrt{2mK}}$$

$$\lambda \propto \frac{1}{\sqrt{m}}$$

$$\frac{\lambda_\alpha}{\lambda_c} = \sqrt{\frac{m_c}{m_\alpha}}$$

$$\frac{\lambda_\alpha}{\lambda_c} = \sqrt{3}$$

10. Two given inputs (A and B) are applied to an AND gate. Then choose the correct output waveform

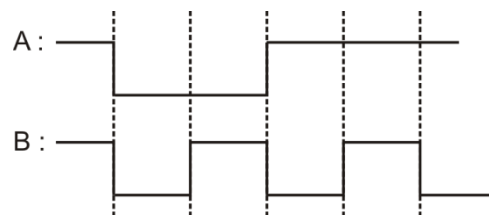

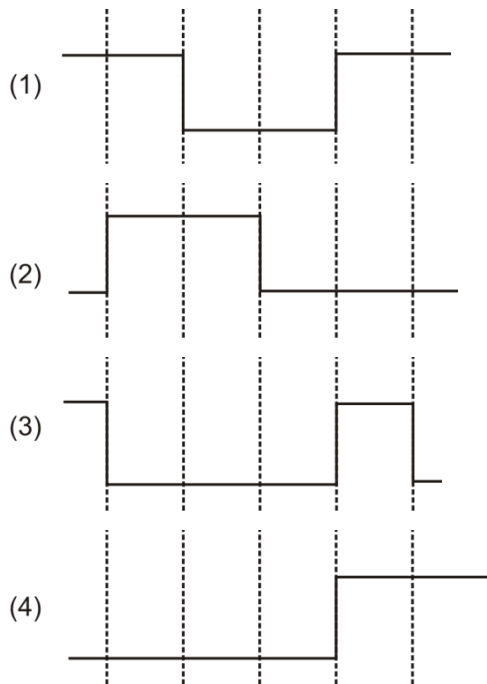

Sol. Answer (3)

Output, $Y = A.B$ for AND gate

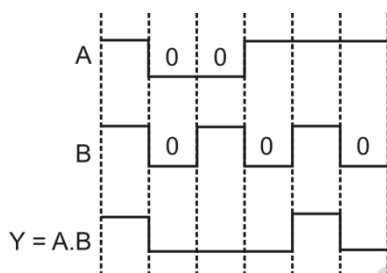

11. A bob is suspended by the means of a thread of length 2m. A bullet of mass 75 gm moving with velocity v penetrates through bob. After collision speed of bullet is $\frac{v}{3}$ and bob is just able to complete vertical circle. If the mass of bob is 50 gm, then the value of v is

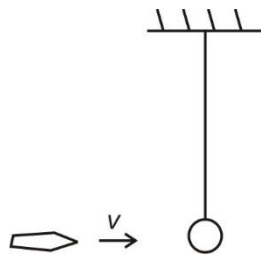

- (1) 7.5 m/s
 (2) 10 m/s
 (3) 15 m/s
 (4) 100 m/s

Sol. Answer (2)

Velocity of bullet immediately after collision
 $= \frac{v}{3}$

Velocity of bob immediately after collision
 $= \sqrt{5gL}$

Apply conservation of momentum

$$mv + 0 = \frac{mv}{3} + m' \sqrt{5gL}$$

$$m = 75 \times 10^{-3} \text{ kg}$$

$$m' = 50 \times 10^{-3} \text{ kg}$$

$$L = 2 \text{ m}$$

$$mv \left[\frac{2}{3} \right] = m' \sqrt{5gL}$$

$$(75 \times 10^{-3}) v \left[\frac{2}{3} \right] = 50 \times 10^{-3} \sqrt{5 \times 10 \times 2}$$

$$v = 10 \text{ m/s}$$

12. A ball of mass m moving with speed v collides head on and elastically with another ball of mass $5m$. Find the absolute % change in kinetic energy of the lighter ball.

- (1) 22.22%
 (2) 44.44%
 (3) 66.66%
 (4) 55.56%

Sol. Answer (4)

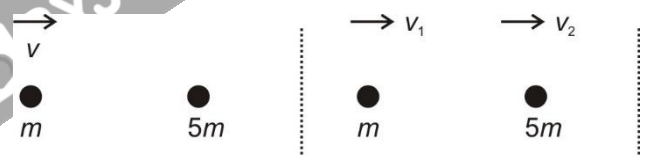

$$mv = mv_1 + 5mv_2$$

$$v = v_1 + 5v_2 \quad \dots\dots(i)$$

$$v = v_2 - v_1 \quad \dots\dots(ii)$$

From (i) and (ii)

$$v_2 = \frac{v}{3}$$

$$v_1 = -\frac{2v}{3}$$

For lighter ball

$$k_i = \frac{1}{2} mv^2$$

$$k_f = \frac{1}{2} m \left(-\frac{2v}{3} \right)^2 = \frac{4}{9} \cdot \frac{1}{2} mv^2$$

$$\% \Delta k = \frac{\Delta k}{k} \times 100$$

$$= \frac{5}{9} \times 100$$

$$= 55.56\%$$

13. For the refraction shown, $i = 2r$ then the value of angle of incidence is

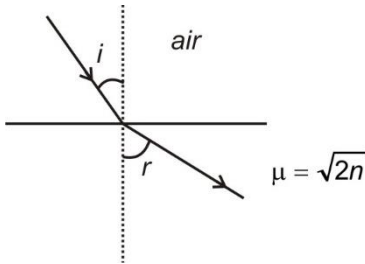

- (1) $\cos^{-1} \sqrt{\frac{n}{2}}$
 (2) $\cos^{-1} \sqrt{2n}$
 (3) $2 \cos^{-1} \sqrt{\frac{n}{2}}$
 (4) $2 \cos^{-1} \sqrt{2n}$

Sol. Answer (3)

Applying snell's law

$$1 \times \sin i = \sqrt{2n} \sin r$$

given $i = 2r$

$$2 \sin \frac{i}{2} \cos \frac{i}{2} = \sqrt{2n} \sin \frac{i}{2}$$

$$2 \cos \frac{i}{2} = \sqrt{2n}$$

$$\cos \frac{i}{2} = \frac{\sqrt{2n}}{2}$$

$$i = 2 \cos^{-1} \left[\sqrt{\frac{n}{2}} \right]$$

14. **Statement 1** : Law of gravitation is Applicable for all bodies in the universe

Statement 2 : Weight of body at earth's centre is zero

Choose the correct option regarding the above statements.

- (1) Both statements are true
 (2) Statement 1 is true and statement 2 is false
 (3) Statement 1 is false and statement 2 is true
 (4) Both statements are false

Sol. Answer (1)

Newton's law of gravitation is universal law and valid for all object in the universe.

At the centre of earth acceleration due to gravity is zero, so, weight of body at earth's centre is zero.

Both statements are correct.

15. Find the dimensional formula of self-inductance.

- (1) $[ML^2TA^{-1}]$
 (2) $[M^2LTA^{-2}]$
 (3) $[ML^2T^{-2}A^{-2}]$
 (4) $[M^2L^2TA^{-3}]$

Sol. Answer (3)

$$U = \frac{1}{2} LI^2$$

$$[L] = \frac{[U]}{[I]^2} = \frac{[M^1L^2T^{-2}]}{[A]^2} = [M^1L^2T^{-2}A^{-2}]$$

16. In a young's double slit setup, first minima is formed opposite to slit. Find the wavelength used if $d = 0.6 \text{ mm}$ and $D = 80 \text{ cm}$.

- (1) 450 nm
 (2) 350 nm
 (3) 500 nm
 (4) 650 nm

Sol. Answer (1)

$$\omega = d$$

$$\frac{\lambda D}{d} = d$$

$$\lambda = \frac{d^2}{D}$$

$$\lambda = \frac{(0.6 \times 10^{-3})^2}{80 \times 10^{-2}}$$

$$\lambda = \frac{36 \times 10^{-8}}{8 \times 10^{-1}}$$

$$\lambda = 4.5 \times 10^{-7} \text{ m}$$

$$\lambda = 450 \text{ nm}$$

17. A particle performs SHM with amplitude A . It is found at mean position at $t = 0$ and at half of the amplitude at $t = 3 \text{ s}$., Find the time period of the SHM.

- (1) 30 s
 (2) 42 s
 (3) 24 s

(4) 36 s

Sol. Answer (4)

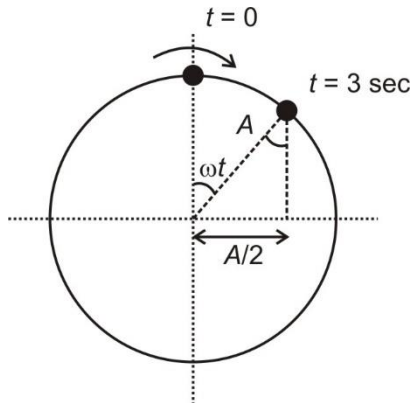

$$\sin \omega t = \frac{A}{2A}$$

$$\sin \omega t = \frac{1}{2}$$

$$\omega t = \frac{\pi}{6}$$

$$\omega(3) = \frac{\pi}{6}$$

$$\omega = \frac{\pi}{18}$$

$$T = \frac{2\pi}{\omega} = \frac{2\pi}{\frac{\pi}{18}} = 36 \text{ sec}$$

18. An observer is moving towards a stationary light source with the speed of $c/5$. What is the percentage change in the frequency?

- (1) 22.5%
- (2) 15.4%
- (3) 20%
- (4) 18.5%

Sol. Answer (1)

$$v_{app} = v_0 \sqrt{\frac{1 + \frac{v}{c}}{1 - \frac{v}{c}}}$$

$$= v_0 \sqrt{\frac{1 + \frac{1}{5}}{1 - \frac{1}{5}}} = v_0 \sqrt{\frac{3}{2}}$$

$$= 1.224 v_0$$

$$\% \Delta v_0 = \frac{\Delta v}{v_0} \times 100 = 22.4\%$$

$$\sim 22.5\%$$

19. The susceptibility of a material is 99. Then find the relative permeability of the material.

- (1) 98
- (2) 100
- (3) 199
- (4) 50

Sol. Answer (2)

$$\text{Given } X_m = 99$$

$$\mu_r = 1 + X_m$$

$$\mu_r = 100$$

20. A carnot cycle is operating between 527°C and 200 K . If work done in a cycle is $W = 12 \text{ KJ}$ then, heat absorbed in the cycle is

- (1) 8 KJ
- (2) 16 KJ
- (3) 9 KJ
- (4) 6 KJ

Sol. Answer (2)

$$\eta = 1 - \frac{T_2}{T_1}$$

$$\eta = 1 - \frac{200}{800}$$

$$\eta = \frac{3}{4}$$

$$\eta = \frac{W}{Q}$$

$$Q = \frac{W}{\eta} = \frac{12 \text{ KJ}}{\frac{3}{4}}$$

$$Q = 16 \text{ KJ}$$

21. Find the value of resistance R for which the bulb glows to its brightest intensity

25V, 5W

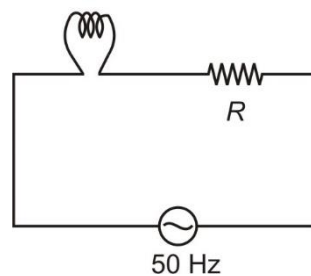

- (1) 50Ω
- (2) 125Ω
- (3) 100Ω

(4) $150\ \Omega$

Sol. Answer (2)

Given rated power = 5W

Rated voltage = 25 V

$$R' = \frac{(25)^2}{5} = 125\ \Omega$$

From power transfer theorem (if we assume that R is internal resistance of AC source)

$$R = R'$$

$$R = 125\ \Omega$$

22. A galvanometer of resistance $72\ \Omega$ is shunted by a resistance of $8\ \Omega$. Then find the percentage of total current which passes through the galvanometer.

Sol. Answer (10)

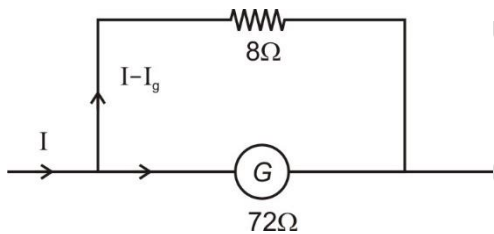

$$I_g = \left[\frac{8}{72 + 8} \right] I$$

$$\frac{I_g}{I} = \frac{1}{10} = 0.1$$

% of total current that passes through galvanometer = 10

23. Find λ of emitted photon for transition in Li^{+2} from 3rd orbit to 1st orbit in nm.

Sol. Answer (11.40)

$$\frac{1}{\lambda} = R(z^2) \left(\frac{1}{n_1^2} - \frac{1}{n_2^2} \right)$$

$$\frac{1}{\lambda} = 1.097 \times 10^7 \times 9 \left(\frac{1}{1} - \frac{1}{9} \right)$$

$$\frac{1}{\lambda} = 1.097 \times 1 \times 8 \times 10^7$$

$$\lambda = \frac{1}{8.776 \times 10^7}$$

$$\lambda = 0.114 \times 10^{-7} \text{ m}$$

$$\lambda = 1.14 \times 10^{-8} \text{ m} = 11.40 \text{ nm}$$

24. A body of mass m and density d_1 fall on liquid of density d_2 and attains terminal velocity. Find viscous force

(1) Mg

(2) $Mg \left(\frac{d_2}{d_1} \right)$

(3) $Mg \left(1 - \frac{d_2}{d_1} \right)$

(4) $Mg \left(1 + \frac{d_2}{d_1} \right)$

Sol. Answer (3)

When body attains terminal velocity

$$Mg = F_b + F_v$$

$$F_v = Mg - F_b$$

$$F_v = Mg - vd_2g$$

$$F_v = Mg - \frac{M}{d_1} d_2 g$$

$$F_v = Mg \left(1 - \frac{d_2}{d_1} \right)$$

25. A transmitter antenna has height of 49 m & receiver antenna has height 25 m find maximum distance through which signal can be transmitted in km is

Sol. Answer (42.93)

$$d = \sqrt{2Rh_T} + \sqrt{2Rh_R}$$

$$d = 7\sqrt{2R} + 5\sqrt{2R}$$

$$d = 12\sqrt{2R}$$

$$d = 12\sqrt{2 \times 6400 \times 10^3}$$

$$d = 42.93 \text{ km}$$

26. Force on a point charge placed between the plates of capacitor is 10 N. What will be force if one plate is removed

(1) Zero

(2) 5 N

(3) 10 N

(4) 20 N

Sol. Answer (2)

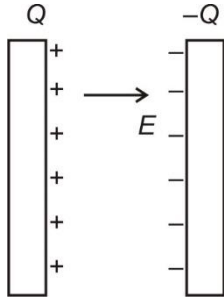

$$F = qE = 10$$

$$q \frac{\sigma}{\epsilon_0} = 10$$

$$q \frac{Q}{A \epsilon_0} = 10 \text{ N}$$

$$\sigma = \frac{Q}{A}$$

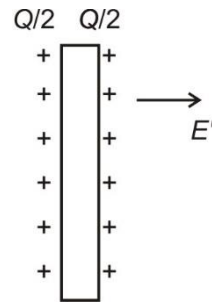

$$E' = \frac{\sigma'}{\epsilon_0}$$

$$F' = qE' = \frac{q\sigma'}{\epsilon_0} = 5 \text{ N} \quad \sigma' = \frac{Q}{2A}$$

$$= \frac{qQ}{2A \epsilon_0} = 5 \text{ N}$$

□□□□

