

STANDARD XII

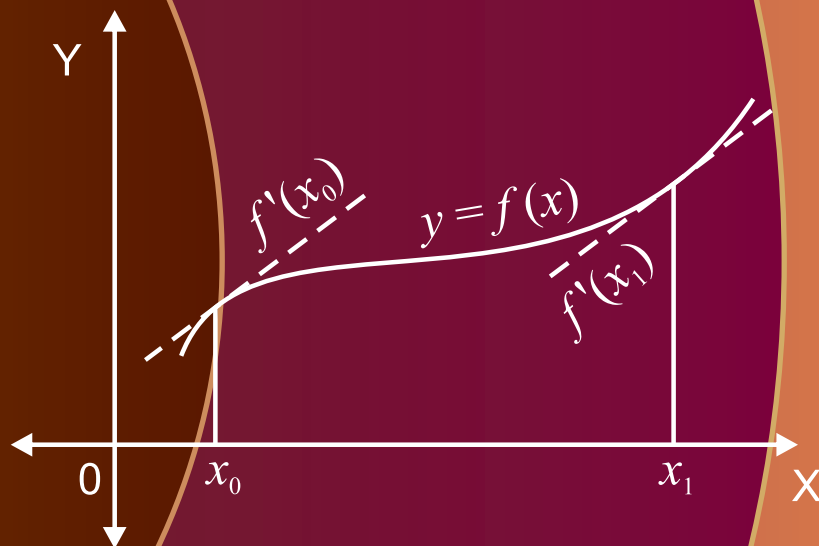

# Mathematics & Statistics

## Commerce Part 1

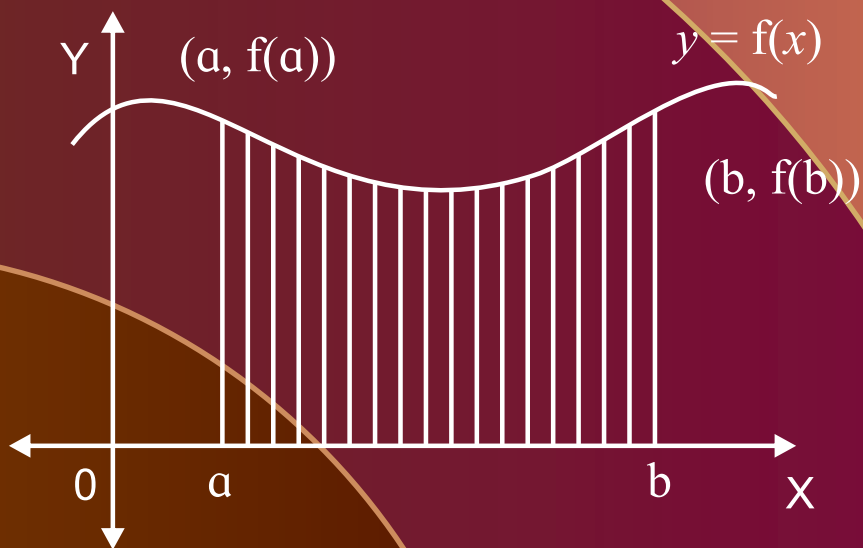

# The Constitution of India

## Chapter IV A

### Fundamental Duties

#### ARTICLE 51A

**Fundamental Duties- It shall be the duty of every citizen of India—**

- (a) to abide by the Constitution and respect its ideals and institutions, the National Flag and the National Anthem;
- (b) to cherish and follow the noble ideals which inspired our national struggle for freedom;
- (c) to uphold and protect the sovereignty, unity and integrity of India;
- (d) to defend the country and render national service when called upon to do so;
- (e) to promote harmony and the spirit of common brotherhood amongst all the people of India transcending religious, linguistic and regional or sectional diversities, to renounce practices derogatory to the dignity of women;
- (f) to value and preserve the rich heritage of our composite culture;
- (g) to protect and improve the natural environment including forests, lakes, rivers and wild life and to have compassion for living creatures;
- (h) to develop the scientific temper, humanism and the spirit of inquiry and reform;
- (i) to safeguard public property and to abjure violence;
- (j) to strive towards excellence in all spheres of individual and collective activity so that the nation constantly rises to higher levels of endeavour and achievement;
- (k) who is a parent or guardian to provide opportunities for education to his child or, as the case may be, ward between the age of six and fourteen years.

The Coordination Committee formed by GR No. Abhyas - 2116/(Pra.Kra.43/16) SD - 4  
Dated 25.4.2016 has given approval to prescribe this textbook in its meeting held on  
30.01.2020 and it has been decided to implement it from the educational year 2020-21.

# Mathematics and Statistics

## (Commerce)

### Part - I

#### STANDARD TWELVE



**Maharashtra State Bureau of Textbook Production and Curriculum Research,  
Pune - 411 004**



E6I4V2

Download DIKSHA App on your smartphone. If you scan the Q.R.Code on this page of your textbook, you will be able to access full text and the audio-visual study material relevant to each lesson provided as teaching and learning aids.

**First Edition : 2020 © Maharashtra State Bureau of Textbook Production  
First Reprint : 2021 and Curriculum Research, Pune- 411 004.**

Maharashtra State Bureau of Textbook Production and Curriculum  
Research reserves all rights relating to the book. No part of this book should  
be reproduced without the written permission of the Director, Maharashtra  
State Bureau of Textbook Production and curriculum Research, Pune.

### **Mathematics and Statistics (Commerce) Committee Members**

Dr. Sharad Gore	(Chairman)
Dr. Mangla Narlikar	(Member)
Shri. Milind Patil	(Member)
Shri. Pradip Bhavsar	(Member)
Smt. Prajkti Gokhale	(Member)
Shri. Pralhad Chippalagatti	(Member)
Shri. Prasad Kunte	(Member)
Shri. Sujit Shinde	(Member)
Shri. Ramakant Sarode	(Member)
Smt. Ujjwala Godbole	(Member-Secretary)

### **Mathematics and Statistics (Commerce) Study Group Members**

Dr. Ishwar Patil	Dr. Pradeep Mugale
Dr. Pradnyankumar Bhojekar	Smt. Pradnya Kashikar
Shri. Uday Mahindrakar	Shri. Balkrishna Mapari
Smt. Nileema Khaldkar	Shri. Devanand Bagul
Shri. Pravin Phalake	Shri. Swapnil Shinde
Shri. Pratap Kashid	Shri. Vilas Bagore
Smt. Rajashri Shinde	Smt. Gauri Prachand
Smt. Swati Powar	Smt. Mahadevi Mane
Shri. Dhananjay Panhalkar	Shri. Sachin Batwal
Shri. Sharadchandra Walagade	Smt. Supriya Abhyankar
Shri. Prafullchandra Pawar	Shri. Dilip Panchamia
Shri. Amit Totade	Smt. Deepti Kharapas
Shri. Pramod Deshpande	

### **Typesetter**

Baladev Computers, Mumbai

### **Cover, Illustrations and Computer Drawings**

Shri. Sandip Koli, Artist, Mumbai

### **Co-ordinator**

Ujjwala Shrikant Godbole  
I/C Special Officer for Mathematics

### **Production**

**Sachchitanand Aphale**

Chief Production Officer

**Sanjay Kamble**

Production Officer

**Prashant Harne**

Asst. Production Officer

### **Paper**

70 GSM Cream wove

**Print Order No.**

N/PB/2021-22/10,000

### **Printer**

SHREE OFFSET PRINTING, KOLHAPUR

### **Publisher**

**Vivek Uttam Gosavi, Controller**

Maharashtra State Textbook Bureau,  
Prabhadevi Mumbai- 400 025



## The Constitution of India

### Preamble

WE, THE PEOPLE OF INDIA, having solemnly resolved to constitute India into a SOVEREIGN SOCIALIST SECULAR DEMOCRATIC REPUBLIC and to secure to all its citizens:

JUSTICE, social, economic and political;  
LIBERTY of thought, expression, belief, faith and worship;  
EQUALITY of status and of opportunity;  
and to promote among them all  
FRATERNITY assuring the dignity of the individual and the unity and integrity of the Nation;

IN OUR CONSTITUENT ASSEMBLY this twenty-sixth day of November, 1949, do HEREBY ADOPT, ENACT AND GIVE TO OURSELVES THIS CONSTITUTION.

## NATIONAL ANTHEM

Jana-gana-mana-adhināyaka jaya hē  
Bhārata-bhāgya-vidhātā,

Panjāba-Sindhu-Gujarāta-Marāthā  
Drāvida-Utkala-Banga

Vindhya-Himāchala-Yamunā-Gangā  
uchchala-jaladhi-taranga

Tava subha nāmē jāgē, tava subha āsisa māgē,  
gāhē tava jaya-gāthā,

Jana-gana-mangala-dāyaka jaya hē  
Bhārata-bhāgya-vidhātā,

Jaya hē, Jaya hē, Jaya hē,  
Jaya jaya jaya, jaya hē.

## PLEDGE

India is my country. All Indians  
are my brothers and sisters.

I love my country, and I am proud  
of its rich and varied heritage. I shall  
always strive to be worthy of it.

I shall give my parents, teachers  
and all elders respect, and treat  
everyone with courtesy.

To my country and my people,  
I pledge my devotion. In their  
well-being and prosperity alone lies  
my happiness.

## PREFACE

Dear Students,

Welcome to Standard XII, an important milestone in your student life.

Standard XII or Higher Secondary Certificate opens the doors of higher education. After successfully completing the higher secondary education, you can pursue higher education for acquiring knowledge and qualification. Alternatively, you can pursue other career paths like joining the workforce. Either way, you will find that mathematics education helps you every day. Learning mathematics enables you to think logically, consistently, and rationally. The curriculum for Standard XII Commerce Mathematics and Statistics has been designed and developed keeping both of these possibilities in mind.

The curriculum of Mathematics and Statistics for Standard XII Commerce is divided in two parts. Part I deals with more theoretical topics like Mathematical Logic, Differentiation and Integration. Part II deals with application oriented topics in finance and management. Random Variables and Probability Distributions are introduced so that you will understand how uncertainty can be handled with the help of probability distributions.

The new text books have three types of exercises for focused and comprehensive practice. First, there are exercises on every important topic. Second, there are comprehensive exercises at end of all chapters. Third, every chapter includes activities that students must attempt after discussion with classmates and teachers. Textbooks cannot provide all the information that the student can find useful. Additional information has been provided on the E-balbharati website ([www.ebalbharati.in](http://www.ebalbharati.in)).

We are living in the age of the Internet. You can make use of the modern technology with help of the Q.R. code given on the title page. The Q.R. code will take you to websites that provide additional useful information. Your learning will be fruitful if you balance between reading the text books and solving exercises. Solving more problems will make you more confident and efficient.

The text books are prepared by a subject committee and a study group. The Bureau is grateful to the members of the subject committee, study group and review committee for sparing their valuable time while preparing these text books. The books are reviewed by experienced teachers and eminent scholars. The Bureau would like to thank all of them for their valuable contribution in the form of creative writing, constructive criticism and useful suggestions for making the text books valuable.

The Bureau wishes and hopes that students find the text book useful in their studies. Students, all the best wishes for happy learning and well deserved success.



**(Vivek Gosavi)**

**Director**

**Pune**

**Date : 21 February 2020**

**Bharatiya Saur: 2 Phalguna 1941**

Maharashtra State Bureau of Textbook  
Production and Curriculum Research, Pune.

## Competency statement

Sr. No.	Area/Topic	Competency statements
1	Mathematical Logic	<p>The student will be able to</p> <ul style="list-style-type: none"> <li>• identify statement in logic and its truth value</li> <li>• use connectives to combine two or more logical statements</li> <li>• identify tautology, contradiction and contingency by constructing a truth table</li> <li>• examine logical equivalence of statement patterns</li> <li>• find the dual of a statement pattern</li> <li>• form the negation of a statement pattern</li> </ul>
2	Matrices	<ul style="list-style-type: none"> <li>• identify the order of a matrix</li> <li>• identify types of matrices</li> <li>• perform fundamental matrix operations after verifying conformity</li> <li>• perform elementary transformation on rows and columns of a matrix</li> <li>• find the inverse of a matrix using elementary transformations and adjoint method</li> <li>• verify the conditions for a matrix to be Invertible</li> <li>• use matrix algebra to solve a system of linear equations</li> </ul>
3	Differentiation	<ul style="list-style-type: none"> <li>• state standard formulae of differentiation</li> <li>• state and use the chain rule of differentiation</li> <li>• find derivatives using logarithms</li> <li>• find derivatives of implicit functions</li> <li>• find derivatives of parametric functions</li> <li>• understand the notion of higher order derivatives and find second order derivatives</li> </ul>
4	Applications of Derivatives	<ul style="list-style-type: none"> <li>• determine whether a function is increasing or decreasing</li> <li>• apply differentiation in Economics</li> <li>• find maximum and minimum values of a function</li> <li>• solve optimization problems in Commerce and Economics</li> </ul>



5	Integration	<ul style="list-style-type: none"> <li>• understand the relationship between differentiation and integration</li> <li>• use standard formulae of integration</li> <li>• use fundamental rules of integration</li> <li>• use the method of substitution for integration</li> <li>• identify integrals of special types</li> <li>• find integrals using integration by parts</li> <li>• use important formulae of integration</li> <li>• use partial fraction in integration</li> </ul>
6	Definite Integration	<ul style="list-style-type: none"> <li>• understand the relationship between indefinite and definite integrals</li> <li>• remember fundamental theorems of integral calculus</li> <li>• remember properties of definite integrals and use them in solving problems</li> </ul>
7	Application of Definite Integration	<ul style="list-style-type: none"> <li>• find area bounded by specified lines and curves.</li> </ul>
8	Differential Equation and Applications	<ul style="list-style-type: none"> <li>• identify order and degree of a differential equation</li> <li>• form a differential equation</li> <li>• solve a differential equation</li> <li>• use variables separable and substitution methods to solve first order and first degree differential equations</li> <li>• solve homogeneous and linear differential equations</li> <li>• use differential equations to solve problems on growth and decay of populations and assets</li> </ul>

# INDEX

<b>Sr. No.</b>	<b>Chapter</b>	<b>Page No.</b>
1	Mathematical Logic	1
2	Matrices	35
3	Differentiation	89
4	Applications of Derivatives	103
5	Integration	116
6	Definite Integration	141
7	Application of Definite Integration	152
8	Differential Equation and Applications	160
	Answers	174



### Let's Study

- **Statement**
- **Logical connectives**
- **Quantifiers and quantified statements**
- **Statement patterns and logical equivalence**
- **Algebra of statements**
- **Venn diagrams**

### Introduction:

Mathematics is an exact science. Every statement must be precise. There has to be proper reasoning in every mathematical proof. Proper reasoning involves Logic. Logic related to mathematics has been developed over last 100 years or so. The axiomatic approach to logic was first propounded by the English philosopher and mathematician George Boole. Hence it is known as Boolean logic or mathematical logic or symbolic logic.

The word 'logic' is derived from the Greek word 'Logos' which means reason. Thus Logic deals with the method of reasoning. Aristotle (382-322 B.C.), the great philosopher and thinker laid down the foundations of study of logic in a systematic form. The study of logic helps in increasing one's ability of systematic and logical reasoning and develop the skill of understanding validity of statements.

### 1.1 Statement:

A statement is a declarative sentence which is either true or false but not both simultaneously. Statements are denoted by letters like p,q,r, ....

### For example:

- i) 2 is a prime number.
- ii) Every rectangle is a square.
- iii) The Sun rises in the West.
- iv) Mumbai is the capital of Maharashtra.

### Truth value of a statement:

A statement is either true or false. The truth value of a 'true' statement is denoted by T (TRUE) and that of a false statement is denoted by F (FALSE).

### Example 1:

- Observe the following sentences.
- i) The Sun rises in the East.
  - ii) The square of a real number is negative.
  - iii) Sum of two odd numbers is odd.
  - iv) Sum of opposite angles in a cyclic rectangle is  $180^\circ$ .

Here, the truth value of statements (i) and (iv) is T, and that of (ii) and (iii) is F.

**Note:** The sentences like exclamatory, interrogative, imperative are not considered as statements.

### Example 2:

- Observe the following sentences.
- i) May God bless you!
  - ii) Why are you so unhappy?
  - iii) Remember me when we are parted.
  - iv) Don't ever touch my phone.
  - v) I hate you!
  - vi) Where do you want to go today?

The above sentences cannot be assigned truth values, so none of them is a statement.

The sentences (i) and (v) are exclamatory.  
The sentences (ii) and (vi) are interrogative.  
The sentences (iii) and (iv) are imperative.

### Open sentences:

An open sentence is a sentence whose truth can vary according to some conditions which are not stated in the sentence.

**Example 3:** Observe the following.

- i)  $x + 4 = 8$
- ii) Chinese food is very tasty

Each of the above sentences is an open sentence, because truth of (i) depends on the value of  $x$ ; if  $x = 4$ , it is true and if  $x \neq 4$ , it is false and that of (ii) varies as degree of tasty food varies from individual to individual.

### Note:

- i) An open sentence is not considered a statement in logic.
- ii) Mathematical identities are true statements.

**For example:**

$$a + 0 = 0 + a = a, \text{ for any real number } a.$$

### Activity:

Determine whether the following sentences are statements in logic and write down the truth values of the statements.

Sr. No.	Sentence	Whether it is a statement or not (yes/No)	If 'No' then reason	Truth value of statement
1.	$\sqrt{-9}$ is a rational number	Yes	—	False 'F'.
2.	Can you speak in French?	No	Interrogative	—
3.	Tokyo is in Gujrat	Yes	—	False 'F'.
4.	Fantastic, let's go!	No	Exclamatory	—
5.	Please open the door quickly.	No	Imperative	—
6.	Square of an even number is even.	<input type="text"/>	<input type="text"/>	True 'T'
7.	$x + 5 < 14$	<input type="text"/>	<input type="text"/>	<input type="text"/>
8.	5 is a perfect square	<input type="text"/>	<input type="text"/>	<input type="text"/>
9.	West Bengal is capital of Kolkata.	<input type="text"/>	<input type="text"/>	<input type="text"/>
10.	$i^2 = -1$	<input type="text"/>	<input type="text"/>	<input type="text"/>

(Note: Complete the above table)

### EXERCISE 1.1

State which of the following sentences are statements. Justify your answer if it is a statement. Write down its truth value.

- i) A triangle has 'n' sides
- ii) The sum of interior angles of a triangle is  $180^\circ$
- iii) You are amazing!
- iv) Please grant me a loan.
- v)  $\sqrt{-4}$  is an irrational number.
- vi)  $x^2 - 6x + 8 = 0$  implies  $x = -4$  or  $x = -2$ .

- vii) He is an actor.
- viii) Did you eat lunch yet?
- ix) Have a cup of cappuccino.
- x)  $(x + y)^2 = x^2 + 2xy + y^2$  for all  $x, y \in \mathbb{R}$ .
- xi) Every real number is a complex number.
- xii) 1 is a prime number.
- xiii) With the sunset the day ends.
- xiv)  $1 \neq 0$
- xv)  $3 + 5 > 11$
- xvi) The number  $\Pi$  is an irrational number.
- xvii)  $x^2 - y^2 = (x + y)(x - y)$  for all  $x, y \in \mathbb{R}$ .
- xviii) The number 2 is the only even prime number.
- xix) Two co-planar lines are either parallel or intersecting.
- xx) The number of arrangements of 7 girls in a row for a photograph is  $7!$ .
- xxi) Give me a compass box.
- xxii) Bring the motor car here.
- xxiii) It may rain today.
- xxiv) If  $a + b < 7$ , where  $a \geq 0$  and  $b \geq 0$  then  $a < 7$  and  $b < 7$ .
- xxv) Can you speak in English?

## 1.2 Logical connectives:

A logical connective is also called a logical operator, sentential connective or sentential operator. It is a symbol or word used to connect two or more sentences in a grammatically valid way.

### Observe the following sentences.

- i) Monsoon is very good this year and the rivers are rising.
- ii) Sneha is fat or unhappy.
- iii) If it rains heavily, then the school will be closed.
- iv) A triangle is equilateral if and only if it is equiangular.

The words or group of words such as “and”, “or”, “if ... then”, “If and only if”, can be used to join or connect two or more simple sentences. These connecting words are called logical connectives.

**Note:** ‘not’ is a logical operator for a single statement. It changes the truth value from T to F and F to T.

### Compound Statement:

A compound statement is a statement which is formed by combining two or more simple statements with help of logical connectives.

The above four sentences are compound sentences.

### Note:

- i) Each of the statements that comprise a compound statement is called a sub-statement or a component statement.
- ii) Truth value of a compound statement depends on the truth values of the sub-statements i.e. constituent simple statements and connectives used. Every simple statement has its truth value either ‘T’ or ‘F’. Thus, while determining the truth value of a compound statement, we have to consider all possible combinations of truth values of the simple statements and connectives. This can be easily expressed with the help of a truth table.

**Table 1.1: Logical connectives**

Sr. No.	Connective	Symbol	Name of corresponding compound statement
1.	and	$\wedge$	conjunction
2.	or	$\vee$	disjunction
3.	not	$\sim$	Negation
4.	If ... then	$\rightarrow$ (or $\Rightarrow$ )	conditional or implication
5.	If and only if or iff	$\Leftrightarrow$ (or $\Leftrightarrow$ )	Biconditional or double implication

**A) Conjunction ( $\wedge$ ):**

If  $p$  and  $q$  are any two statements connected by the word “and”, then the resulting compound statement “ $p$  and  $q$ ” is called the conjunction of  $p$  and  $q$ , which is written in the symbolic form as ‘ $p \wedge q$ ’.

**For example:**

Let  $p : \sqrt{2}$  is a rational number  
 $q : 4 + 3i$  is a complex number

The conjunction of the above two statements is  $p \wedge q$  i.e.  $\sqrt{2}$  a rational number and  $4 + 3i$  is a complex number.

**Consider the following simple statements:**

- i)  $5 > 3$  ; Nagpur is in Vidarbha.  
 $p : 5 > 3$   
 $q : \text{Nagpur is in Vidarbha}$   
 The conjunction is  
 $p \wedge q : 5 > 3$  and Nagpur is in Vidarbha.
- ii)  $p : a+bi$  is irrational number for all  $a, b \in R$ ;  
 $q : 0 \neq 1$   
 The conjunction is  
 $p \wedge q : a + bi$  is irrational number,  
 for all  $a, b \in R$  and  $0 \neq 1$

**Truth table of conjunction ( $p \wedge q$ )**

**Table 1.2**

p	q	$p \wedge q$
T	T	T
T	F	F
F	T	F
F	F	F

From the last column, the truth values of above four combinations can be decided.

**Remark:**

- i) Conjunction is true if both sub-statements are true. Otherwise it is false.

- ii) Other English words such as “but”, “yet”, “though”, “still”, “moreover” are also used to join two simple statements instead of “and”.
- iii) Conjunction of two statements corresponds to the “intersection of two sets” in set theory.

**SOLVED EXAMPLES**

**Ex. 1:** Write the following statements in symbolic form.

- i) An angle is a right angle and its measure is  $90^\circ$ .
- ii) Jupiter is a planet and Mars is a star.
- iii) Every square is a rectangle and  $3 + 5 < 2$ .

**Solution:**

- i) Let  $p : \text{An angle is right angle.}$   
 $q : \text{Its measure is } 90^\circ.$   
 Then,  $p \wedge q$  is the symbolic form.
- ii) Let  $p : \text{Jupiter is planet}$   
 $q : \text{Mars is a star.}$   
 Then,  $p \wedge q$  is the symbolic form.
- iii) Let  $p : \dots\dots\dots$   
 $q : \dots\dots\dots$   
 Then,  $\dots\dots\dots$

**Ex. 2:** Write the truth value of each of the following statements.

- i) Patna is capital of Bihar and  $5i$  is an imaginary number.
- ii) Patna is capital of Bihar and  $5i$  is not an imaginary number.
- iii) Patna is not capital of Bihar and  $5i$  is an imaginary number.
- iv) Patna is not capital of Bihar and  $5i$  is not an imaginary number.

**Solution:** Let  $p : \text{Patna is capital of Bihar}$   
 $q : 5i$  is an imaginary number  
 $p$  is true;  $q$  is true.



## EXERCISE 1.2

**Ex. 1:** Express the following statements in symbolic form.

- i)  $e$  is a vowel or  $2 + 3 = 5$
- ii) Mango is a fruit but potato is a vegetable.
- iii) Milk is white or grass is green.
- iv) I like playing but not singing.
- v) Even though it is cloudy, it is still raining.

**Ex. 2:** Write the truth values of following statements.

- i) Earth is a planet and Moon is a star.
- ii) 16 is an even number and 8 is a perfect square.
- iii) A quadratic equation has two distinct roots or 6 has three prime factors.
- iv) The Himalayas are the highest mountains but they are part of India in the North East.

### C) Negation ( $\sim$ ):

The denial of an assertion contained in a statement is called its negation.

The negation of a statement is generally formed by inserting the word “not” at some proper place in the statement or by prefixing the statement with “it is not the case that” or “it is false that” or “it is not true that”.

The negation of a statement  $p$  is written as  $\sim p$  (read as “negation  $p$ ” or “not  $p$ ”) in symbolic form.

### For example:

Let  $p$  : 2 is an even number

$\sim p$  : 2 is not an even number.

or  $\sim p$  : It is not the case that 2 is an even number

or  $\sim p$  : It is false that 2 is an even number

- ii) In this sentence ‘or’ is used for indicating approximate number of students and not as a connective. Therefore, it is a simple statement and it is expressed as

$p$  : Four or five students did not attend the lectures.

**Ex. 2:** Write the truth values of the following statements.

- i) India is a democratic country or China is a communist country.
- ii) India is a democratic country or China is not a communist country.
- iii) India is not a democratic country or China is a communist country.
- iv) India is not a democratic country or China is not a communist country.

**Solution:**  $p$  : India is a democratic country.

$q$  : China is a communist country.

$p$  is true;  $q$  is true.

- i) True (T), since both the sub-statements are true i.e. both “India is a democratic country” and “China is a communist country” are true. (As  $T \vee T = T$ )
- ii) True (T), since first sub-statements “India is a democratic country” is true and second sub-statement “China is not a communist country” is false. (As  $T \vee F = T$ )
- iii) True (T), since first sub-statements “India is not a democratic country” is false and second sub-statement “China is a communist country” is true. (As  $F \vee T = T$ )
- iv) False (F), since both the sub-statements “India is not a democratic country” and “China is not a communist country” are false. (As  $F \vee F = F$ )



### The truth table of negation ( $\sim p$ )

Table 1.4

p	$\sim p$
T	F
F	T

**Note:** Negation of a statement is equivalent to the complement of a set in set theory.

#### SOLVED EXAMPLES

**Ex. 1:** Write the negation of the following statements.

- i)  $p$  : He is honest.
- ii)  $q$  :  $\pi$  is an irrational number.

**Solution:**

- i)  $\sim p$  : He is not honest  
or  $\sim p$  : It is not the case that he is honest  
or  $\sim p$  : It is false that he is honest.
- ii)  $\sim q$  :  $\pi$  is not an irrational number.  
or  $\sim q$  :   
or  $\sim q$  :

#### EXERCISE 1.3

1. Write the negation of each of the following statements.
  - i) All men are animals.
  - ii)  $-3$  is a natural number.
  - iii) It is false that Nagpur is capital of Maharashtra
  - iv)  $2 + 3 \neq 5$
2. Write the truth value of the negation of each of the following statements.
  - i)  $\sqrt{5}$  is an irrational number
  - ii) London is in England
  - iii) For every  $x \in \mathbb{N}$ ,  $x + 3 < 8$ .

### D) Conditional statement (Implication, $\rightarrow$ )

If two simple statements  $p$  and  $q$  are connected by the group of words “If ... then ...”, then the resulting compound statement “If  $p$  then  $q$ ” is called a conditional statement (implication) and is written in symbolic form as “ $p \rightarrow q$ ” (read as “ $p$  implies  $q$ ”).

**For example:**

- i) Let  $p$  : There is rain  
 $q$  : The match will be cancelled  
then,  $p \rightarrow q$  : If there is rain then the match will be cancelled.
- ii) Let  $p$  :  $r$  is a rational number.  
 $q$  :  $r$  is a real number.  
then,  $p \rightarrow q$  : If  $r$  is a rational number then  $r$  is a real number.

### The truth table for conditional statement

( $p \rightarrow q$ )

Table 1.5

p	q	$p \rightarrow q$
T	T	T
T	F	F
F	T	T
F	F	T

#### SOLVED EXAMPLES

**Ex. 1:** Express the following statements in the symbolic form.

- i) If the train reaches on time, then I can catch the connecting flight.
- ii) If price increases then demand falls.

**Solution:**

- i) Let  $p$  : The train reaches on time  
 $q$  : I can catch the connecting flight.  
Therefore,  $p \rightarrow q$  is symbolic form.

- ii) Let  $p$  : price increases  
 $q$  : demand falls  
 Therefore,  $p \rightarrow q$  is symbolic form.

**Ex. 2:** Write the truth value of each of the following statements.

- If Rome is in Italy then Paris is in France.
- If Rome is in Italy then Paris is not in France.
- If Rome is not in Italy then Paris is in France.
- If Rome is not in Italy then Paris not in France.

**Solution:**

$p$  : Rome is in Italy  
 $q$  : Paris is in France  
 $p$  is true ;  $q$  is true.

- True (T), since both the sub-statements are true. i.e. Rome is in Italy and Paris is in France are true. (As  $T \rightarrow T = T$ )
- False (F), since first sub-statement Rome is in Italy is true and second sub-statement Paris in not in France is false.  
 (As  $T \rightarrow F = F$ )
- True (T), since first sub-statement Rome is not in Italy is false and second sub-statement Paris is in France is true. (As  $F \rightarrow T = T$ )
- True (T), since both the sub-statements are false. i.e. Rome is not in Italy and Paris is not in France both are false. (As  $F \rightarrow F = T$ )

**E) Biconditional (Double implication) ( $\leftrightarrow$ ) or ( $\Leftrightarrow$ ):**

If two statements  $p$  and  $q$  are connected by the group of words “If and only if” or “iff”, then the resulting compound statement “ $p$  if and only if  $q$ ” is called biconditional of  $p$  and  $q$ , is written in symbolic form as  $p \leftrightarrow q$  and read as “ $p$  if and only if  $q$ ”.

**For example:**

- Let  $p$  : Milk is white  
 $q$  : the sky is blue  
 Therefore,  $p \leftrightarrow q$  : Milk is white if and only if the sky is blue.
- Let  $p$  :  $3 < 5$   
 $q$  :  $4\sqrt{2}$  is an irrational number.  
 Therefore,  $p \leftrightarrow q$  :  $3 < 5$  if and only if  $4\sqrt{2}$  is an irrational number.

**Truth table for biconditional ( $p \leftrightarrow q$ )**

**Table 1.6**

$p$	$q$	$p \leftrightarrow q$
T	T	T
T	F	F
F	T	F
F	F	T

**SOLVED EXAMPLES**

**Ex. 1:** Translate the following statements (verbal form) to symbolic form.

- Price increases if and only if demand falls.
- $5 + 4 = 9$  if and only if  $3 + 2 = 7$

**Solution:**

- Let  $p$  : Price increases  
 $q$  : demand falls  
 Therefore,  $p \leftrightarrow q$  is the symbolic form.
- Let  $p$  :  $5 + 4 = 9$   
 $q$  :  $3 + 2 = 7$   
 Therefore,  $p \leftrightarrow q$  is the symbolic form.

**Ex. 2:** Write the truth value of each of the following statements.

- The Sun rises in the East if and only if  $4 + 3 = 7$
- The Sun rises in the East if and only if  $4 + 3 = 10$

- iii) The Sun rises in the West if and only if  $4 + 3 = 7$
- iv) The Sun rises in the West if and only if  $4 + 3 = 10$

**Solution:**

$p$  : The Sun rises in the East;  
 $q$  :  $4 + 3 = 7$ ;  
 $p$  is true,  $q$  is true.

The truth value of each statement is given by

- i) True (T), since both the sub-statements (i.e. “The Sun rises in the East” and “ $4 + 3 = 7$ ”) are true. (As  $T \leftrightarrow T = T$ )
  - ii) False (F), since both the sub-statements have opposite truth values (i.e. “The Sun rises in the East” is true but “ $4 + 3 = 10$ ” is false.). (As  $T \leftrightarrow F = F$ )
  - iii) False (F), since both the sub-statements have opposite truth values (i.e. “The Sun rises in the East” is false but “ $4 + 3 = 7$ ” is true.). (As  $F \leftrightarrow T = F$ )
  - iv) True (T), since both the sub-statements have same truth values (i.e. they are false.) (As  $F \leftrightarrow F = T$ )
- Therefore,  $p \leftrightarrow q$  is the symbolic form.

**Note:**

- i) The biconditional statement  $p \leftrightarrow q$  is the compound statement “ $p \rightarrow q$ ” and “ $q \rightarrow p$ ” of two compound statements.
- ii)  $p \leftrightarrow q$  can also be read as –
  - a)  $q$  if and only if  $p$ .
  - b)  $p$  is necessary and sufficient for  $q$ .
  - c)  $q$  is necessary and sufficient for  $p$ .
  - d)  $p$  implies  $q$  and  $q$  implies  $p$ .
  - e)  $p$  implies and is implied by  $q$ .

**Ex. 1:** Express the following in symbolic form using logical connectives.

- i) If a quadrilateral is a square then it is not a rhombus.

- ii) It is false that Nagpur is capital of India iff  $3 + 2 = 4$
- iii) ABCD is a parallelogram but it is not a quadrilateral.
- iv) It is false that  $3^2 + 4^2 = 5^2$  or  $\sqrt{2}$  is not a rational number but  $3^2 + 4^2 = 5^2$  and  $8 > 3$ .

**Solution:**

- i) Let  $p$  : quadrilateral is a square  
 $q$  : quadrilateral is a rhombus.  
 Then,  $p \rightarrow \sim q$  is symbolic form.
- ii) Let  $p$  : Nagpur is capital of India  
 $q$  :  $3 + 2 = 4$   
 Then,  $\sim p \leftrightarrow q$  is the symbolic form.
- iii) Let  $p$  : ABCD is a parallelogram  
 $q$  : ABCD is a quadrilateral  
 Then,  $p \wedge \sim q$  is the symbolic form.
- iv) Let  $p$  :  $3^2 + 4^2 = 5^2$   
 $q$  :  $\sqrt{2}$  is a rational number  
 $r$  :  $8 > 3$ .

Therefore,  $(\sim p \vee \sim q) \wedge (p \wedge r)$  is the symbolic form of the required statement.

**Ex. 2:** Express the following statements in symbolic form and write their truth values.

- i) It is not true that  $\sqrt{2}$  is a rational number.
- ii) 4 is an odd number iff 3 is not a prime factor of 6.
- iii) It is not true that  $i$  is a real number.

**Solution:**

- i) Let  $p$  :  $\sqrt{2}$  is a rational number.  
 Then  $\sim p$  is the symbolic form.  
 Given statement,  $p$  is false F.  
 $\therefore \sim p \equiv T$   
 $\therefore$  the truth value of given statement is T.
- ii) Let  $p$  : 4 is an odd number.  
 $q$  : 3 is a prime factor of 6.  
 $\sim q$  : 3 is not a prime factor of 6.

Therefore,  $p \leftrightarrow (\sim q)$  is the symbolic form.  
 Given statement,  $p$  is false F.

$q$  is true T.

$\therefore \sim q$  is false F.

$\therefore p \leftrightarrow (\sim q) \equiv F \leftrightarrow F \equiv T$

$\therefore$  the truth value of given statement is T.

iii) Let  $p : i$  is a real number.

$\therefore \sim p$  : It is not true that  $i$  is a real number.

Therefore,  $\sim p$  : is the symbolic form.

$p$  is false F.

$\therefore \sim p$  : is true T.

$\therefore$  the truth value of the given statement is T.

### Construct truth table

Table 1.7

$p$	$q$	$r$	$s$	$\sim q$	$\sim s$	$p \leftrightarrow \sim q$	$r \leftrightarrow \sim s$	$(p \leftrightarrow \sim q) \wedge (r \leftrightarrow \sim s)$
T	T	F	F	F	T	F	F	F

ii) Without truth table :

$$\begin{aligned} (p \rightarrow r) \vee (q \rightarrow s) &= (T \rightarrow F) \vee (T \rightarrow F) \\ &= F \vee F \\ &= F \end{aligned}$$

### Construct truth table

Table 1.8

$p$	$q$	$r$	$s$	$p \rightarrow r$	$q \rightarrow s$	$(p \rightarrow r) \vee (q \rightarrow s)$
T	T	F	F	F	F	F

ii) Without truth table : (Activity)

$$\begin{aligned} &\sim [(p \wedge \sim s) \vee (q \wedge \sim r)] \\ &= \sim [(\square \wedge \sim \square) \vee (\square \wedge \square)] \\ &= \sim [(\square \wedge T) \vee (T \wedge T)] \\ &= \sim (\square \vee \square) \\ &= \sim (\square) \\ &= \square \end{aligned}$$

**Ex. 3:** If  $p$  and  $q$  are true and  $r$  and  $s$  are false, find the truth value of each of the following.

i)  $(p \leftrightarrow \sim q) \wedge (r \leftrightarrow \sim s)$

ii)  $(p \rightarrow r) \vee (q \rightarrow s)$

iii)  $\sim [(p \wedge \sim s) \vee (q \wedge \sim r)]$

### Solution:

i) Without truth table :  $(p \leftrightarrow \sim q) \wedge (r \leftrightarrow \sim s)$   
 $= (T \leftrightarrow \sim T) \wedge (F \leftrightarrow \sim F)$   
 $= (T \leftrightarrow F) \wedge (F \leftrightarrow T)$   
 $= F \wedge F$   
 $= F$

### Construct truth table

Table 1.9

(Note: Construct truth table and complete your solution)

## EXERCISE 1.4

**Ex. 1:** Write the following statements in symbolic form.

- If triangle is equilateral then it is equiangular.
- It is not true that “ $i$ ” is a real number.
- Even though it is not cloudy, it is still raining.
- Milk is white if and only if the sky is not blue.
- Stock prices are high if and only if stocks are rising.
- If Kutub-Minar is in Delhi then Taj-Mahal is in Agra.

**Ex. 2:** Find truth value of each of the following statements.

- i) It is not true that  $3 - 7i$  is a real number.
- ii) If a joint venture is a temporary partnership, then discount on purchase is credited to the supplier.
- iii) Every accountant is free to apply his own accounting rules if and only if machinery is an asset.
- iv) Neither 27 is a prime number nor divisible by 4.
- v) 3 is a prime number and an odd number.

**Ex. 3:** If  $p$  and  $q$  are true and  $r$  and  $s$  are false, find the truth value of each of the following compound statements.

- i)  $p \wedge (q \wedge r)$
- ii)  $(p \rightarrow q) \vee (r \wedge s)$
- iii)  $\sim [(\sim p \vee s) \wedge (\sim q \wedge r)]$
- iv)  $(p \rightarrow q) \leftrightarrow \sim (p \vee q)$
- v)  $[(p \vee s) \rightarrow r] \vee \sim [\sim (p \rightarrow q) \vee s]$
- vi)  $\sim [p \vee (r \wedge s)] \wedge \sim [(r \wedge \sim s) \wedge q]$

**Ex. 4:** Assuming that the following statements are true,

$p$  : Sunday is holiday,

$q$  : Ram does not study on holiday,

find the truth values of the following statements.

- i) Sunday is not holiday or Ram studies on holiday.
- ii) If Sunday is not holiday then Ram studies on holiday.
- iii) Sunday is a holiday and Ram studies on holiday.

**Ex. 5:** If  $p$  : He swims

$q$  : Water is warm

Give the verbal statements for the following symbolic statements.

- i)  $p \leftrightarrow \sim q$
- ii)  $\sim (p \vee q)$
- iii)  $q \rightarrow p$
- iv)  $q \wedge \sim p$

## 1.2.1 Quantifiers and Quantified statements:

- i) For every  $x \in \mathbb{R}$ ,  $x^2$  is non negative. We shall now see how to write this statement using symbols. ' $\forall x$ ' is used to denote "For all  $x$ ".

Thus, the above statement may be written in mathematical notation  $\forall z \in \mathbb{R}, z^2 \geq 0$ . The symbol ' $\forall$ ' stands for "For all values of". This is known as **universal quantifier**.

- ii) Also we can get  $x \in \mathbb{N}$  such that  $x + 4 = 7$ . To write this in symbols we use the symbol  $\exists x$  to denote "there exists  $x$ ". Thus, we have  $\exists x \in \mathbb{N}$  such that  $x + 4 = 7$ .

The symbol  $\exists$  stands for "there exists". This symbol is known as **existential quantifier**.

Thus, there are two types of quantifiers.

- a) Universal quantifier ( $\forall$ )
- b) Existential quantifier ( $\exists$ )

### Quantified statement:

An open sentence with a quantifier becomes a statement and is called a quantified statement.

## SOLVED EXAMPLES

**Ex. 1:** Use quantifiers to convert each of the following open sentences defined on  $\mathbb{N}$ , into a true statement.

- i)  $2x + 3 = 11$
- ii)  $x^3 < 64$
- iii)  $x + 5 < 9$

### Solution:

- i)  $\exists x \in \mathbb{N}$  such that  $2x + 3 = 11$ . It is a true statement, since  $x = 4 \in \mathbb{N}$  satisfies  $2x + 3 = 11$ .
- ii)  $x^3 < 64 \quad \exists x \in \mathbb{N}$  such that it is a true statement, since  $x = 1$  or  $2$  or  $3 \in \mathbb{N}$  satisfies  $x^3 < 64$ .
- iii)  $\exists x \in \mathbb{N}$  such that  $x + 5 < 9$ . It is a true statement for  $x = 1$  or  $2$  or  $3 \in \mathbb{N}$  satisfies  $x + 5 < 9$ .

**Ex. 2:** If  $A = \{1, 3, 5, 7\}$  determine the truth value of each of the following statements.

- i)  $\exists x \in A$ , such that  $x^2 < 1$ .
- ii)  $\exists x \in A$ , such that  $x + 5 \leq 10$
- iii)  $\forall x \in A$ ,  $x + 3 < 9$

**Solution:**

- i) No number in set  $A$  satisfies  $x^2 < 1$ , since the square of every natural number is 1 or greater than 1.  
 $\therefore$  the given statement is false, hence its truth value is F.
- ii) Clearly,  $x = 1, 3$  or  $5$  satisfies  $x + 5 \leq 10$ . So the given statement is true, hence truth value is T.
- iii) Since  $x = 7 \in A$  does not satisfy  $x + 3 < 9$ , the given statement is false. Hence its truth value is F.

### EXERCISE 1.5

**Ex. 1:** Use quantifiers to convert each of the following open sentences defined on  $\mathbb{N}$ , into a true statement.

- i)  $x^2 + 3x - 10 = 0$
- ii)  $3x - 4 < 9$
- iii)  $n^2 \geq 1$
- iv)  $2n - 1 = 5$
- v)  $Y + 4 > 6$
- vi)  $3y - 2 \leq 9$

**Ex. 2:** If  $B = \{2, 3, 5, 6, 7\}$  determine the truth value of each of the following.

- i)  $\forall x \in B$  such that  $x$  is prime number.
- ii)  $\exists n \in B$ , such that  $n + 6 > 12$
- iii)  $\exists n \in B$ , such that  $2n + 2 < 4$
- iv)  $\forall y \in B$  such that  $y^2$  is negative
- v)  $\forall y \in B$  such that  $(y - 5) \in \mathbb{N}$

### 1.3 Statement Patterns and Logical Equivalence:

#### A) Statement Patterns:

Let  $p, q, r, \dots$  be simple statements. A compound statement obtained from these simple statements by using one or more of the connectives  $\wedge, \vee, \rightarrow, \leftrightarrow$ , is called a statement pattern.

**For example:**

- i)  $(p \vee q) \rightarrow r$
- ii)  $p \wedge (q \wedge r)$
- iii)  $\sim (p \vee q)$  are statement patterns

**Note:** While preparing truth tables of the given statement patterns, the following points should be noted.

- i) If a statement pattern involves  $n$  component statements  $p, q, r, \dots$  and each of  $p, q, r, \dots$  has 2 possible truth values namely T and F, then the truth table of the statement pattern consists of  $2^n$  rows.
- ii) If a statement pattern contains “ $m$ ” connectives and “ $n$ ” component statements then the truth table of the statement pattern consists of  $(m + n)$  columns.
- iii) Parentheses must be introduced whenever necessary.

**For example:**

$\sim (p \rightarrow q)$  and  $\sim p \rightarrow q$  are not the same.

### SOLVED EXAMPLES

**Ex. 1:** Prepare the truth table for each of the following statement patterns.

- i)  $[(p \rightarrow q) \vee p] \rightarrow p$
- ii)  $\sim [p \vee q] \rightarrow \sim (p \wedge q)$
- iii)  $(\sim p \vee q) \vee \sim q$
- iv)  $(p \wedge r) \vee (q \wedge r)$

**Solution:**

- i)  $[(p \rightarrow q) \vee p] \rightarrow p$

**Truth table 1.10**

$p$	$q$	$p \rightarrow q$	$(p \rightarrow q) \vee p$	$[(p \rightarrow q) \vee p] \rightarrow p$
T	T	T	T	T
T	F	F	T	T
F	T	T	T	F
F	F	T	T	F

- ii)  $\sim (p \vee q) \rightarrow \sim (p \wedge q)$

**Truth table 1.11**

$p$	$q$	$p \vee q$	$\sim(p \vee q)$	$(p \wedge q)$	$\sim(p \wedge q)$	$\sim(p \vee q) \rightarrow \sim(p \wedge q)$
T	T	T	F	T	F	T
T	F	T	F	F	T	T
F	T	T	F	F	T	T
F	F	F	T	F	T	T

iii)  $(\sim p \vee q) \vee \sim q$

**Truth table 1.12**

$p$	$q$	$\sim p$	$\sim q$	$\sim p \vee q$	$(\sim p \vee q) \vee \sim q$
T	T	F	F	T	T
T	F	F	T	F	T
F	T	T	F	T	T
F	F	T	T	T	T

iv)  $(p \wedge r) \vee (q \wedge r)$

Complete the following truth table :

**Truth table 1.13**

$p$	$q$	$r$	$p \wedge r$	$q \wedge r$	$(p \wedge r) \vee (q \wedge r)$
T	<input type="checkbox"/>	T	T	<input type="checkbox"/>	T
T	<input type="checkbox"/>	<input type="checkbox"/>	F	F	<input type="checkbox"/>
<input type="checkbox"/>	F	T	T	<input type="checkbox"/>	<input type="checkbox"/>
<input type="checkbox"/>	<input type="checkbox"/>	<input type="checkbox"/>	F	F	<input type="checkbox"/>
F	<input type="checkbox"/>	T	<input type="checkbox"/>	<input type="checkbox"/>	F
<input type="checkbox"/>	T	F	<input type="checkbox"/>	<input type="checkbox"/>	F
<input type="checkbox"/>	<input type="checkbox"/>	T	<input type="checkbox"/>	<input type="checkbox"/>	<input type="checkbox"/>
F	<input type="checkbox"/>	F	F	<input type="checkbox"/>	<input type="checkbox"/>

**B) Logical Equivalence:**

Two or more statement patterns are said to be logically equivalent if and only if the truth values in their respective columns in the joint truth table are identical.

If  $s_1, s_2, s_3, \dots$  are logically equivalent statement patterns, we write  $s_1 \equiv s_2 \equiv s_3 \equiv \dots$

**For example:** Using a truth table, verify that

i)  $\sim(p \wedge q) \equiv \sim p \vee \sim q$

ii)  $\sim(p \vee q) \equiv \sim p \wedge \sim q$

iii)  $p \vee (q \vee r) \equiv (p \vee q) \vee (p \vee r)$

iv)  $\sim r \rightarrow \sim(p \wedge q) \equiv \sim(q \rightarrow r) \rightarrow \sim p$

**Solution:**

i)  $\sim(p \wedge q) \equiv \sim p \vee \sim q$

**Truth table 1.14**

$p$	$q$	$\sim p$	$\sim q$	$p \wedge q$	$\sim(p \wedge q)$	$\sim p \vee \sim q$
1	2	3	4	5	6	7
T	T	F	F	T	F	F
T	F	F	T	F	T	T
F	T	T	F	F	T	T
F	F	T	T	F	T	T

From the truth table 1.14, we observe that all entries in 6<sup>th</sup> and 7<sup>th</sup> columns are identical.

$\therefore \sim(p \wedge q) \equiv \sim p \vee \sim q$

ii)  $\sim(p \vee q) \equiv \sim p \wedge \sim q$

**Truth table 1.15**

$p$	$q$	$\sim p$	$\sim q$	$p \vee q$	$\sim(p \vee q)$	$\sim p \wedge \sim q$
1	2	3	4	5	6	7
T	T	F	F	T	F	F
T	F	F	T	T	F	F
F	T	T	F	T	F	F
F	F	T	T	F	T	T

From the truth table 1.15, we observe that all entries in 6<sup>th</sup> and 7<sup>th</sup> columns are identical.

$\therefore \sim(p \vee q) \equiv \sim p \wedge \sim q$

iii) **Activity**

$$p \vee (q \vee r) \equiv (p \vee q) \vee (p \vee r)$$

**Truth table 1.16**

$p$	$q$	$r$	$q \vee r$	$P \vee (q \vee r)$	$p \vee q$	$p \vee r$	$(p \vee q) \vee (p \vee r)$
1	2	3	4	5	6	7	8
T	T	<input type="checkbox"/>	T	<input type="checkbox"/>	T	<input type="checkbox"/>	<input type="checkbox"/>
T	T	<input type="checkbox"/>	T	<input type="checkbox"/>	<input type="checkbox"/>	T	<input type="checkbox"/>
<input type="checkbox"/>	F	T	<input type="checkbox"/>	T	<input type="checkbox"/>	<input type="checkbox"/>	T
<input type="checkbox"/>	F	F	<input type="checkbox"/>	<input type="checkbox"/>	T	T	T
F	<input type="checkbox"/>	<input type="checkbox"/>	T	T	<input type="checkbox"/>	<input type="checkbox"/>	<input type="checkbox"/>
F	<input type="checkbox"/>	<input type="checkbox"/>	T	T	T	F	T
<input type="checkbox"/>	<input type="checkbox"/>	<input type="checkbox"/>	T	<input type="checkbox"/>	F	T	T
<input type="checkbox"/>	<input type="checkbox"/>	F	<input type="checkbox"/>	<input type="checkbox"/>	<input type="checkbox"/>	<input type="checkbox"/>	F

From the truth table 1.16, we observe that all entries in 5th and 8th columns are identical.

$$\therefore p \vee (q \vee r) \equiv (p \vee q) \vee (p \vee r)$$

iv) **Activity**

$$\sim r \rightarrow \sim (p \wedge q) \equiv \sim (q \rightarrow r) \rightarrow \sim p$$

**Prepare the truth table 1.17**

$p$	$q$	$r$	$\sim p$	$\sim r$	$p \wedge q$	$\sim (p \wedge q)$	$\sim r \rightarrow \sim (p \wedge q)$	$q \rightarrow r$	$\sim (q \rightarrow r)$	$\sim (q \rightarrow r) \rightarrow \sim p$

**C) Tautology, contradiction, contingency:**

component statements is called a tautology.

**Tautology:**

**For example:**

A statement pattern always having the truth value 'T', irrespective of the truth values of its

Consider  $(p \wedge q) \rightarrow (p \vee q)$



**Truth table 1.18**

$p$	$q$	$p \wedge q$	$p \vee q$	$(p \wedge q) \rightarrow (p \vee q)$
T	T	T	T	T
T	F	F	T	T
F	T	F	T	T
F	F	F	F	T

In the above table, all the entries in the last column are T. Therefore, the given statement pattern is a tautology.

**Contradiction:**

A statement pattern always having the truth value 'F' irrespective of the truth values of its component statements is called a contradiction.

**For example:**

Consider  $p \wedge \sim p$

**Truth table 1.19**

$p$	$\sim p$	$p \wedge \sim p$
T	F	F
F	T	F

In the above truth table, all the entries in the last column are F. Therefore, the given statement pattern is a contradiction.

**Contingency:**

A statement pattern which is neither a tautology nor a contradiction is called a contingency.

**For example:**

Consider  $(p \rightarrow q) \wedge (q \rightarrow p)$

**Truth table 1.20**

$p$	$q$	$p \rightarrow q$	$q \rightarrow p$	$(p \rightarrow q) \wedge (q \rightarrow p)$
T	T	T	T	T
T	F	F	T	F
F	T	T	F	F
F	F	T	T	T

In the table 1.20, the entries in the last column are not all T and not all F. Therefore, the given statement pattern is a contingency.

**SOLVED EXAMPLES**

**Ex. 1:** Using the truth table, examine whether the following statement patterns are tautology, contradictions or contingency.

- i)  $(p \wedge q) \rightarrow p$
- ii)  $(\sim p \vee \sim q) \leftrightarrow \sim (p \wedge q)$
- iii)  $(\sim q \wedge p) \wedge q$
- iv)  $p \rightarrow (\sim q \vee r)$

**Solution:**

- i) The truth table for  $(p \wedge q) \rightarrow p$

**Truth table 1.21**

$p$	$q$	$p \wedge q$	$(p \wedge q) \rightarrow p$
T	T	T	T
T	F	F	T
F	T	F	T
F	F	F	T

In the table 1.21, all the entries in the last column are T. Therefore, the given statement pattern is a tautology.

- ii) **Activity:**

Prepare the truth table for  $(\sim p \vee \sim q) \leftrightarrow \sim (p \wedge q)$

**Truth table 1.22**

$p$	$q$	$\sim p$	$\sim q$	$p \wedge q$	$\sim (p \wedge q)$	$(\sim p \vee \sim q)$	$(\sim p \vee \sim q) \leftrightarrow \sim (p \wedge q)$

- iii) The truth table for  $(\sim q \wedge p) \wedge q$

**Truth table 1.23**

$p$	$q$	$\sim q$	$\sim q \wedge p$	$(\sim q \wedge p) \wedge q$
T	T	F	F	F
T	F	T	T	F
F	T	F	F	F
F	F	T	F	F

In the table 1.23, all the entries in the last column are F.

Therefore, the given statement pattern is a contradiction.

iv) The truth table for  $p \rightarrow (\sim q \vee r)$

**Truth table 1.24**

$p$	$q$	$r$	$\sim q$	$\sim q \vee r$	$p \rightarrow (\sim q \vee r)$
T	T	T	F	T	T
T	T	F	F	F	F
T	F	T	T	T	T
T	F	F	T	T	T
F	T	T	F	T	T
F	T	F	F	F	T
F	F	T	T	T	T
F	F	F	T	T	T

In the table 1.24, the entries in the last column are neither all T nor all F.

Therefore, the given statement pattern is a contingency.

**EXERCISE 1.6**

1. Prepare truth tables for the following statement patterns.

- i)  $p \rightarrow (\sim p \vee q)$
- ii)  $(\sim p \vee q) \wedge (\sim p \vee \sim q)$
- iii)  $(p \wedge r) \rightarrow (p \vee \sim q)$
- iv)  $(p \wedge q) \vee \sim r$

2. Examine whether each of the following statement patterns is a tautology, a contradiction or a contingency

- i)  $q \vee [\sim (p \wedge q)]$
- ii)  $(\sim q \wedge p) \wedge (p \wedge \sim p)$
- iii)  $(p \wedge \sim q) \rightarrow (\sim p \wedge \sim q)$
- iv)  $\sim p \rightarrow (p \rightarrow \sim q)$

3. Prove that each of the following statement pattern is a tautology.

- i)  $(p \wedge q) \rightarrow q$
- ii)  $(p \rightarrow q) \leftrightarrow (\sim q \rightarrow \sim p)$
- iii)  $(\sim p \wedge \sim q) \rightarrow (p \rightarrow q)$
- iv)  $(\sim p \vee \sim q) \leftrightarrow \sim (p \wedge q)$

4. Prove that each of the following statement pattern is a contradiction.

- i)  $(p \vee q) \wedge (\sim p \wedge \sim q)$
- ii)  $(p \wedge q) \wedge \sim p$
- iii)  $(p \wedge q) \wedge (\sim p \vee \sim q)$
- iv)  $(p \rightarrow q) \wedge (p \wedge \sim q)$

5. Show that each of the following statement pattern is a contingency.

- i)  $(p \wedge \sim q) \rightarrow (\sim p \wedge \sim q)$
- ii)  $(p \rightarrow q) \leftrightarrow (\sim p \vee q)$
- iii)  $p \wedge [(p \rightarrow \sim q) \rightarrow q]$
- iv)  $(p \rightarrow q) \wedge (p \rightarrow r)$

6. Using the truth table, verify

- i)  $p \vee (q \wedge r) \equiv (p \vee q) \wedge (p \vee r)$
- ii)  $p \rightarrow (p \rightarrow q) \equiv \sim q \rightarrow (p \rightarrow q)$
- iii)  $\sim (p \rightarrow \sim q) \equiv p \wedge \sim (\sim q) \equiv p \wedge q$
- iv)  $\sim (p \vee q) \vee (\sim p \wedge q) \equiv \sim p$

7. Prove that the following pairs of statement patterns are equivalent.

- i)  $p \vee (q \wedge r)$  and  $(p \vee q) \wedge (p \vee r)$
- ii)  $p \leftrightarrow q$  and  $(p \rightarrow q) \wedge (q \rightarrow p)$
- iii)  $p \rightarrow q$  and  $\sim q \rightarrow \sim p$  and  $\sim p \vee q$
- iv)  $\sim (p \wedge q)$  and  $\sim p \vee \sim q$ .

## D) Duality:

Two compound statements  $s_1$  and  $s_2$  are said to be duals of each other, if one can be obtained from the other by replacing  $\wedge$  by  $\vee$  and  $\vee$  by  $\wedge$ , and  $c$  by  $t$  and  $t$  by  $c$ , where  $t$  denotes tautology and  $c$  denotes contradiction.

### Note:

- Dual of a statement is unique.
- The symbol  $\sim$  is not changed while finding the dual.
- Dual of the dual is the original statement itself.
- The connectives  $\wedge$  and  $\vee$ , the special statements  $t$  and  $c$  are duals of each other.
- T is changed to F and vice-versa.

### For example:

- Consider the distributive laws,  
$$p \wedge (q \vee r) \equiv (p \wedge q) \vee (p \wedge r) \dots (1)$$
$$p \vee (q \wedge r) \equiv (p \vee q) \wedge (p \vee r) \dots (2)$$

Observe that (2) can be obtained from (1) by replacing  $\wedge$  by  $\vee$  and  $\vee$  by  $\wedge$  i.e. interchanging  $\wedge$  and  $\vee$ .

Hence (1) is the dual of (2).

Similarly, (1) can be obtained from (2) by replacing  $\vee$  by  $\wedge$  and  $\wedge$  by  $\vee$ . Hence, (2) is the dual of (1).

Therefore, statements (1) and (2) are called duals of each other.

- Consider De-Morgan's laws :

$$\sim (p \wedge q) \equiv \sim p \vee \sim q \dots (1)$$

$$\sim (p \vee q) \equiv \sim p \wedge \sim q \dots (2)$$

Statements, (1) and (2) are duals of each other.

## SOLVED EXAMPLES

**Ex. 1:** Write the duals of the following statements:

- $\sim (p \wedge q) \vee (\sim q \wedge \sim p)$
- $(p \vee q) \wedge (r \vee s)$
- $[(p \wedge q) \vee r] \wedge [(q \wedge r) \vee s]$

**Solution:** The duals are given by

- $\sim (p \vee q) \wedge (\sim q \vee \sim p)$
- $(p \wedge q) \vee (r \wedge s)$
- $[(p \vee q) \wedge r] \vee [(q \vee r) \wedge s]$

**Ex. 2:** Write the duals of the following statements:

- All natural numbers are integers or rational numbers.
- Some roses are red and all lillies are white.

**Solution:** The duals are given by

- All natural numbers are integers and rational numbers.
- Some roses are red or all lillies are white.

## EXERCISE 1.7

- Write the dual of each of the following :

- $(p \vee q) \vee r$
- $\sim (p \vee q) \wedge [p \vee \sim (q \wedge \sim r)]$
- $p \vee (q \vee r) \equiv (p \vee q) \vee r$
- $\sim (p \wedge q) \equiv \sim p \vee \sim q$

- Write the dual statement of each of the following compound statements.

- 13 is prime number and India is a democratic country.
- Karina is very good or every body likes her.
- Radha and Sushmita can not read Urdu.
- A number is real number and the square of the number is non negative.

### E) Negation of a compound statement:

We have studied the negation of simple statements. Negation of a simple statement is obtained by inserting “not” at the appropriate place in the statement e.g. the negation of “Ram is tall” is “Ram is not tall”. But writing negations of compound statements involving conjunction, disjunction, conditional, biconditional etc. is not straight forward.

#### 1) Negation of conjunction:

In section 1.3(B) we have seen that  $\sim(p \wedge q) \equiv \sim p \vee \sim q$ . It means that negation of the conjunction of two simple statements is the disjunction of their negation.

Consider the following conjunction.

“Parth plays cricket and chess.”

Let  $p$  : Parth plays cricket.

$q$  : Parth plays chess.

Given statement is  $p \wedge q$ .

You know that  $\sim(p \wedge q) \equiv \sim p \vee \sim q$

$\therefore$  negation is Parth doesn't play cricket or he doesn't play chess.

#### 2) Negation of disjunction:

In section 1.3(B) we have seen that  $\sim(p \vee q) \equiv \sim p \wedge \sim q$ . It means that negation of the disjunction of two simple statements is the conjunction of their negation.

**For ex:** The number 2 is an even number or the number 2 is a prime number.

Let  $p$  : The number 2 is an even number.

$q$  : The number 2 is a prime number.

$\therefore$  given statement :  $p \vee q$ .

You know that  $\sim(p \vee q) \equiv \sim p \wedge \sim q$

$\therefore$  negation is “The number 2 is not an even number and the number 2 is not a prime number”.

### 3) Negation of negation:

Let  $p$  be a simple statement.

**Truth table 1.25**

$p$	$\sim p$	$\sim(\sim p)$
T	F	T
F	T	F

From the truth table 1.25, we see that

$$\sim(\sim p) \equiv p$$

Thus, the negation of negation of a statement is the original statement -  $\sim(\sim p) \equiv p$ .

#### For example:

Let  $p : \sqrt{5}$  is an irrational number.

The negation of  $p$  is given by

$\sim p : \sqrt{5}$  is not an irrational number.

$\sim(\sim p) : \sqrt{5}$  is an irrational number.

Therefore, negation of negation of  $p$  is  $\sim(\sim p)$  i.e. it is not the case that  $\sqrt{5}$  is not an irrational number.

OR it is false that  $\sqrt{5}$  is not an irrational number.

OR  $\sqrt{5}$  is an irrational number.

#### 4) Negation of Conditional (Implication):

You know that  $p \rightarrow q \equiv \sim p \vee q$

$$\therefore \sim(p \rightarrow q) \equiv \sim(\sim p \vee q)$$

$$\equiv \sim(\sim p) \wedge \sim q \quad \dots \text{by De-Morgan's law}$$

$$\therefore \sim(p \rightarrow q) \equiv p \wedge \sim q$$

We can also prove this result by truth table.

**Truth table 1.26**

$p$	$q$	$p \rightarrow q$	$\sim(p \rightarrow q)$	$\sim q$	$p \wedge \sim q$
1	2	3	4	5	6
T	T	T	F	F	F
T	F	F	T	T	T
F	T	T	F	F	F
F	F	T	F	F	F

All the entries in the columns 4 and 6 of table 1.26 are identical.

$$\therefore \sim(p \rightarrow q) \equiv p \wedge \sim q$$

e.g. If every planet moves around the Sun then every Moon of the planet moves around the Sun.

Negation of the given statement is, Every planet moves around the Sun but (and) every Moon of the planet does not move around the Sun.

### Method 2:

We also prove this by using truth table 1.27.

**Truth Table 1.27**

$p$	$q$	$p \leftrightarrow q$	$\sim(p \leftrightarrow \sim q)$	$\sim p$	$\sim q$	$p \wedge \sim q$	$q \wedge \sim p$	$(p \wedge \sim q) \vee (q \wedge \sim p)$
1	2	3	4	5	6	7	8	9
T	T	T	F	F	F	F	F	F
T	F	F	T	F	T	T	F	T
F	T	F	T	T	F	F	T	T
F	F	T	F	T	T	F	F	F

Since all the entries in the columns 4 and 9 of truth table 1.27 are identical.

$$\therefore \sim(p \leftrightarrow q) \equiv (p \wedge \sim q) \vee (q \wedge \sim p).$$

**For example:**  $2n$  is divisible by 4 if and only if  $n$  is an even integer.

Let  $p$  :  $2n$  is divisible by 4

$q$  :  $n$  is an even integer.

Therefore, negation of the given statement is “ $2n$  is divisible by 4 and  $n$  is not an even integer or  $n$  is an even integer and  $2n$  is not divisible by 4”.

### Note:

Negation of a statement pattern involving one or more of the simple statements  $p, q, r, \dots$  and one or more of the three connectives  $\wedge, \vee, \sim$  can be obtained by replacing  $\wedge$  by  $\vee, \vee$  by  $\wedge$  and replaicng  $p, q, r \dots$  by  $\sim p, \sim q, \sim r. \dots$

## 5) Negation of Biconditional (Double implication):

Consider the biconditional  $p \leftrightarrow q$ .

### Method 1:

We have seen that

$$(p \leftrightarrow q) \equiv (p \rightarrow q) \wedge (q \rightarrow p)$$

$$\therefore \sim(p \leftrightarrow q) \equiv \sim[(p \rightarrow q) \wedge (q \rightarrow p)]$$

$$\equiv \sim(p \rightarrow q) \vee \sim(q \rightarrow p)$$

... by De-Morgans law

$$\equiv (p \wedge \sim q) \vee (q \wedge \sim p)$$

... by negation of the conditional statement

$$\therefore \sim(p \leftrightarrow q) \equiv (p \wedge \sim q) \vee (q \wedge \sim p)$$

**For example:** Consider the statement pattern  $(\sim p \wedge q) \vee (p \vee \sim q)$ . Its negation is given by :

$$\text{i.e. } \sim[(\sim p \wedge q) \vee (p \vee \sim q)]$$

$$\equiv (p \vee \sim q) \wedge (\sim p \wedge q)$$

## 6) Negation of a quantified statement:

While forming negation of a quantified statement, we replace the word ‘all’ by ‘some’, “for every” by “there exists” and vice versa.

### SOLVED EXAMPLES

**Ex. 1:** Write negation of each of the following statements :

- i) All girls are sincere

- ii) If India is playing world cup and Rohit is the captain, then we are sure to win.
- iii) Some bureaucrats are efficient.

**Solution:**

- i) The negation is,  
Some girls are not sincere  
OR, There exists a girl, who is not sincere.

- ii) Let  $p$  : India is playing world cup  
 $q$  : Rohit is the captain  
 $r$  : We win.

The given compound statement is

$$(p \wedge q) \rightarrow r$$

Therefore, the negation is,

$$\sim [(p \wedge q) \rightarrow r] \equiv (p \wedge q) \wedge \sim r$$

India is playing world cup and Rohit is the captain and we are not sure to win.

- iii) The negation is, all bureaucrats are not efficient.

**Converse, Inverse and contrapositive:**

Let  $p$  and  $q$  be simple statements and let  $p \rightarrow q$  be the implication of  $p$  and  $q$ .

Then, i) The converse of  $p \rightarrow q$  is  $q \rightarrow p$ .

ii) Inverse of  $p \rightarrow q$  is  $\sim p \rightarrow \sim q$ .

iii) Contrapositive of  $p \rightarrow q$  is  $\sim q \rightarrow \sim p$ .

**For example:** Write the converse, inverse and contrapositive of the following compound statements.

- i) If a man is rich then he is happy.
- ii) If the train reaches on time then I can catch the connecting flight.

**Solution:**

- i) Let  $p$  : A man is rich.  
 $q$  : He is happy.

Therefore, the symbolic form of the given statement is  $p \rightarrow q$ .

**Converse:**  $q \rightarrow p$  i.e. If a man is happy then he is rich.

**Inverse:**  $\sim p \rightarrow \sim q$  i.e. If a man is not rich then he is not happy.

**Contrapositive:**  $\sim q \rightarrow \sim p$  i.e. If a man is not happy then he is not rich.

- ii) Let  $p$  : The train reaches on time.

$q$  : I can catch the connecting flight.

Therefore, the symbolic form of the given statement is  $p \rightarrow q$ .

Converse,  $q \rightarrow p$  i.e.

Inverse  i.e.

Contrapositive  i.e.

**Ex. 3:** Using the rules of negation, write the negation of the following :

- i)  $(\sim p \wedge r) \vee (p \vee \sim r)$
- ii)  $(p \vee \sim r) \wedge \sim q$
- iii) The crop will be destroyed if there is a flood.

**Solution:**

- i) The negation of  $(\sim p \wedge r) \vee (p \vee \sim r)$  is  $\sim [(\sim p \wedge r) \vee (p \vee \sim r)]$

$$\equiv \sim (\sim p \wedge r) \wedge \sim (p \vee \sim r)$$

... by De-Morgan's law

$$\equiv (p \vee \sim r) \wedge (\sim p \wedge r)$$

... by De-Morgan's law and

$$\sim (\sim p) \equiv p \text{ and } \sim (\sim r) \equiv r.$$

- ii) The negation of  $(p \vee \sim r) \wedge \sim q$  is

$$\sim [(p \vee \sim r) \wedge \sim q]$$

$$\equiv \sim (p \vee \sim r) \vee \sim (\sim q)$$

... by De Morgan's law

$$\equiv (\sim p \wedge r) \vee q$$

... by De Morgan's law and

$$\sim (\sim q) \equiv q.$$

iii) Let  $p$  : The crop will be destroyed.

$q$  : There is a flood.

Therefore, the given statement is  $q \rightarrow p$   
and its negation is  $\sim (q \rightarrow p) \equiv q \wedge \sim p$

i.e. the crop will not be destroyed and there is a flood.

2. Using the rules of negation, write the negations of the following :

i)  $(p \rightarrow r) \wedge q$

ii)  $\sim (p \vee q) \rightarrow r$

iii)  $(\sim p \wedge q) \wedge (\sim q \vee \sim r)$

3. Write the converse, inverse and contrapositive of the following statements.

i) If it snows, then they do not drive the car.

ii) If he studies, then he will go to college.

1. Write negation of each of the following statements.

i) All the stars are shining if it is night.

ii)  $\forall n \in \mathbb{N}, n + 1 > 0$

iii)  $\exists n \in \mathbb{N}, (n^2 + 2)$  is odd number

iv) Some continuous functions are differentiable.

4. With proper justification, state the negation of each of the following.

i)  $(p \rightarrow q) \vee (p \rightarrow r)$

ii)  $(p \leftrightarrow q) \vee (\sim q \rightarrow \sim r)$

iii)  $(p \rightarrow q) \wedge r$

### 1.4 Algebra of statements:

The statement patterns, under the relation of logical equivalence, satisfy various laws. We have already proved a majority of them and the rest are obvious. Now, we list these laws for ready reference.

1.	$p \vee p \equiv p$	Idempotent laws	$p \wedge p \equiv p$
2.	$p \vee (q \vee r)$ $\equiv (p \vee q) \vee r$ $\equiv p \vee q \vee r$	Associative laws	$p \wedge (q \wedge r)$ $\equiv (p \wedge q) \wedge r$ $\equiv (p \wedge q) \wedge r$
3.	$(p \vee q) \equiv q \vee p$	Commutative laws	$p \wedge q \equiv q \wedge p$
4.	$p \vee (q \wedge r)$ $\equiv (p \vee q) \wedge (p \vee r)$	Distributive laws	$p \wedge (q \vee r)$ $\equiv (p \wedge q) \vee (p \wedge r)$
5.	$p \vee c \equiv p$ $p \vee t \equiv t$	Identity laws	$p \wedge c \equiv c$ $p \wedge t \equiv p$
6.	$p \vee \sim p \equiv t$ $\sim t \equiv c$	Complement laws	$p \wedge \sim p \equiv c$ $\sim c \equiv t$
7.	$\sim(\sim p) \equiv p$	Involution law (law of double negation)	
8.	$\sim(p \vee q)$ $\equiv \sim p \wedge \sim q$	DeMorgan's laws	$\sim(p \wedge q)$ $\equiv \sim p \vee \sim q$
9.	$p \rightarrow q$ $\equiv \sim q \rightarrow \sim p$	Contrapositive law	

**Note:** In case of three simple statements p,q,r, we note the following :

- i)  $p \wedge q \wedge r$  is true if and only if  $p, q, r$  are all true and  $p \wedge q \wedge r$  is false even if any one of  $p, q, r$  is false.
- ii)  $p \vee q \vee r$  is false if and only if  $p, q, r$  are all false, otherwise it is true.

### SOLVED EXAMPLES

**Ex. 1:** Without using truth table, show that

- i)  $p \vee (q \wedge \sim q) \equiv p$
- ii)  $\sim (p \vee q) \vee (\sim p \wedge q) \equiv \sim p$
- iii)  $p \vee (\sim p \wedge q) \equiv p \vee q$

**Solution:**

- i)  $p \vee (q \wedge \sim q)$   
 $\equiv p \vee c$  ... by complement law  
 $\equiv p$  ... by Identity law
- ii)  $\sim (p \vee q) \vee (\sim p \wedge q)$   
 $\equiv (\sim p \wedge \sim q) \vee (\sim p \wedge q)$   
... by De Morgans law  
 $\equiv \sim p \wedge (\sim q \vee q)$   
... by Distributive law  
 $\equiv \sim p \wedge t$   
... by Complement law  
 $\equiv \sim p$  ... by Identity law
- iii)  $p \vee (\sim p \wedge q)$   
 $\equiv (p \vee \sim p) \wedge (p \vee q)$   
... by Distributive law  
 $\equiv t \wedge (p \vee q)$  ... by Complement law  
 $\equiv p \vee q$  ... by Identity law

**Ex. 2:** Without using truth table, prove that  $[(p \vee q) \wedge \sim p] \rightarrow q$  is a tautology.

**Solution:**

$$[(p \vee q) \wedge \sim p] \rightarrow q$$

$$\begin{aligned} &\equiv [(p \wedge \sim p) \vee (q \wedge \sim p)] \rightarrow q \\ &\quad \dots \text{ by Distributive law} \\ &\equiv [(c \vee (q \wedge \sim p))] \rightarrow q \\ &\quad \dots \text{ by Complement law} \\ &\equiv (\sim p \wedge q) \rightarrow q \quad \dots \text{ by Commutative law} \\ &\equiv \sim (\sim p \wedge q) \vee q \\ &\quad \dots \text{ by } \sim \sim (p \rightarrow q) \equiv \sim (p \wedge \sim q) \equiv \sim p \vee q \\ &\equiv [(p \vee \sim q) \vee q] \quad \dots \text{ by De Morgan's law} \\ &\equiv p \vee (\sim q \vee q) \quad \dots \text{ by Associative law} \\ &\equiv p \vee t \\ &\equiv t \end{aligned}$$

### EXERCISE 1.9

1. Without using truth table, show that
  - i)  $p \leftrightarrow q \equiv (p \wedge q) \vee (\sim p \wedge \sim q)$
  - ii)  $p \wedge [(\sim p \vee q) \vee \sim q] \equiv p$
  - iii)  $\sim [(p \wedge q) \rightarrow \sim q] \equiv p \wedge q$
  - iv)  $\sim r \rightarrow \sim (p \wedge q) \equiv [(q \rightarrow r)] \rightarrow \sim p$
  - v)  $(p \vee q) \rightarrow r \equiv (p \rightarrow r) \wedge (q \rightarrow r)$
2. Using the algebra of statement, prove that
  - i)  $[p \wedge (q \vee r)] \vee [\sim r \wedge \sim q \wedge p] \equiv p$
  - ii)  $(p \wedge q) \vee (p \wedge \sim q) \vee (\sim p \wedge \sim q) \equiv p \vee \sim q$
  - iii)  $(p \vee q) \wedge (\sim p \vee \sim q) \equiv (p \vee \sim q) \wedge (\sim p \vee q)$

### 1.5 Venn Diagrams:

We have already studied Venn Diagrams while studying set theory. Now we try to investigate the similarity between rules of logical connectives and those of various operations on sets.

The rules of logic and rules of set theory go hand in hand.



- i) Disjunction in logic is equivalent to the union of sets in set theory.
- ii) Conjunction in logic is equivalent to the intersection of sets in set theory.
- iii) Negation of a statement in logic is equivalent to the complement of a set in set theory.
- iv) Implication of two statements in logic is equivalent to ‘subset’ in set theory.
- v) Biconditional of two statements in logic is equivalent to “equality of two sets” in set theory.

Main object of this discussion is actually to give analogy between algebra of statements in logic and operations on sets in set theory.

Let A and B be two nonempty sets

- i) The union of A and B is defined as  
 $A \cup B = \{x / x \in A \text{ or } x \in B\}$
- ii) The intersection of A and B is defined as  
 $A \cap B = \{x / x \in A \text{ and } x \in B\}$
- iii) The difference of A and B (relative complement of B in set A) is defined as  
 $A - B = \{x / x \in A, x \notin B\}$

**Note:** One of the possible relationships between two sets A and B holds .

- i)  $A \subset B$
- ii)  $B \subset A$
- iii)  $A = B$
- iv)  $A \not\subset B, B \not\subset A$  and  $A \cap B \neq \phi$
- v)  $A \not\subset B, B \not\subset A$  and  $A \cap B = \phi$

**Figure:**

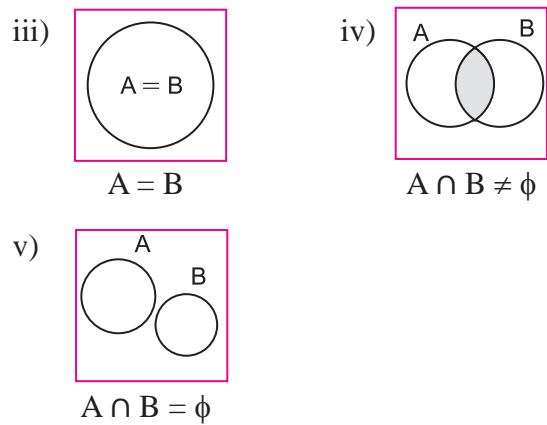
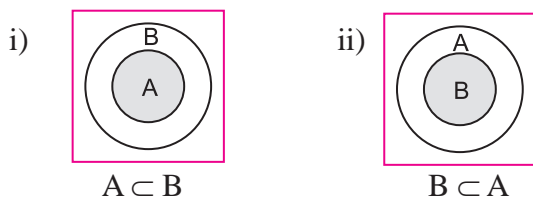

**Fig. 1.1**

**Observe the following four statements**

- i) a) All professors are educated.  
b) Equiangular triangles are precisely equilateral triangles.
- ii) No policeman is a thief.
- iii) Some doctors are rich.
- iv) Some students are not scholars.

These statements can be generalized respectively as

- a) All x’s are y’s                      c) Some x’s are y’s
- b) No x’s are y’s                      d) Some x’s are not y’s

a) Diagram for “All x’s are y’s”

There are two possibilities

- i) All x’s are y’s    i.e.  $x \subset y$
- ii) x’s are precisely y’s    i.e.  $x = y$

**For example:**

i) Consider the statement

“All professors are educated”

Let  $p$  : The set of all professors.

$E$  : The set of all educated people.

Let us choose the universal set as

$u$  : The set of all human beings.

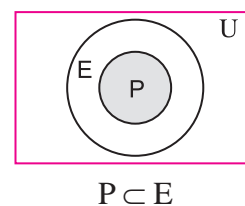

**Fig. 1.2**

The Venn diagram (fig. 1.2) represents the truth of the statement i.e.  $P \subset E$ .

ii) Consider the statement

India will be prosperous if and only if its citizens are hard working.

Let P : The set of all prosperous Indians.

H : The set of all hard working Indians.

U : The set of all human beings.

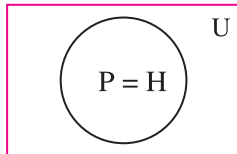

**Fig. 1.3**

The Venn diagram (fig. 1.3) represents the truth of the statement i.e.  $P = H$ .

b) Diagram for “No X’s are Y’s”

i) Consider the statement

No naval person is an airforce person.

Let N : The set of all naval persons.

A : The set of all airforce persons.

Let us choose the universal set as

U : The set all human beings.

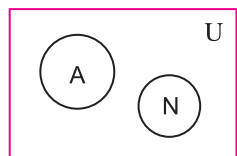

$$N \cap A = \phi$$

**Fig. 1.4**

The Venn diagram (fig. 1.4) represents the truth of the statement i.e.  $N \cap A = \phi$ .

ii) Consider the statement

No even number is an odd numbers.

Let E : The set of all even numbers.

O : The set of all odd numbers.

Let us choose the universal set as

U : The set of all numbers.

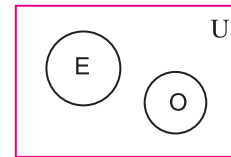

$$E \cap O = \phi$$

**Fig. 1.5**

The Venn diagram (fig. 1.5) represents the truth of the statement i.e.  $E \cap O = \phi$ .

**c) Diagram for “Some X’s are Y’s”**

i) Consider the statement

Some even numbers are multiple of seven.

Let E : The set of all even numbers.

M : The set of all numbers which are multiple of seven.

Let us choose the universal set as

U : The set of all natural numbers.

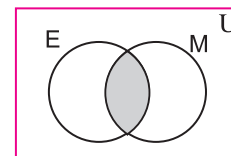

$$E \cap M \neq \phi$$

**Fig. 1.6**

The Venn diagram represents the truth of the statement i.e.  $E \cap M \neq \phi$

ii) Consider the statement

Some real numbers are integers.

Let R : The set of all real numbers.

I : The set of all integers.

Let us choose the universal set as

U : The set of all complex numbers.

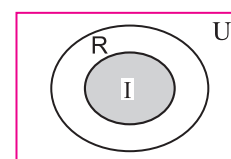

$$I \subset R$$

**Fig. 1.7**

The Venn diagram (fig. 1.7) represents the truth of the statement i.e.  $I \subset R$ .

**d) Diagram for “Some X’s are not Y’s”**

- i) Consider the statement  
Some squares of integers are not odd numbers.

Let S : The set of all squares of integers.

O : The set of all odd numbers.

Let us choose the universal set as

U : The set of all integers.

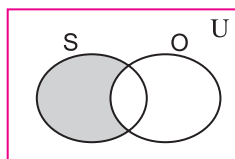

$$S - O \neq \phi$$

**Fig. 1.8**

The Venn diagram (fig. 1.8) represents the truth of the statement i.e.  $S - O \neq \phi$ .

- ii) Consider the statement  
Some rectangles are not squares.

Let R : The set of all rectangles.

S : The set of all squares.

Let us choose the universal set as

U : The set of all quadrilaterals.

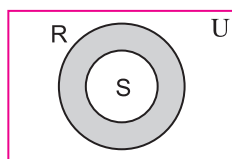

$$R - S \neq \phi$$

**Fig. 1.9**

The Venn diagram (fig. 1.9) represents the truth of the statement i.e.  $R - S \neq \phi$ .

**SOLVED EXAMPLES**

**Ex. 1:** Express the truth of each of the following statement by Venn diagram.

- i) Equilateral triangles are isosceles.
- ii) Some rectangles are squares.
- iii) No co-operative industry is a proprietary firm.
- iv) All rational numbers are real numbers.
- v) Many servants are not graduates.
- vi) Some rational numbers are not integers.
- vii) Some quadratic equations have equal roots.
- viii) All natural numbers are real numbers and  $x$  is not a natural number.

**Solution:**

- i) Let us choose the universal set.  
U : The set of all triangles.  
Let I : The set of all isosceles triangles.  
E : The set of all equilateral triangles.

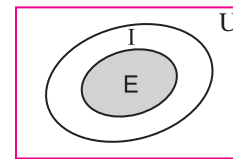

$$E \subset I$$

**Fig. 1.10**

The Venn diagram (fig. 1.10) represents the truth of the given statement i.e.  $E \subset I$ .

- ii) Let us choose the universal set.  
U : The set of all quadrilaterals.  
Let R : The set of all rectangles.  
S : The set of all squares.

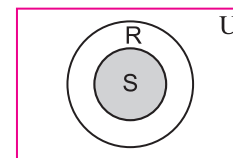

$$R \cap S \neq \phi$$

**Fig. 1.11**

The Venn diagram (fig. 1.11) represents the truth of the given statement i.e.  $R \cap S \neq \phi$ .

- iii) Let us choose the universal set.  
 U : The set of all industries.  
 Let C : The set of all co-operative industries.  
 P : The set of all proprietary firms.

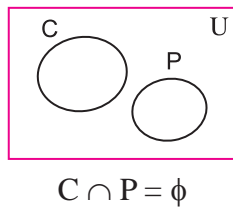

**Fig. 1.12**

The Venn diagram (fig. 1.12) represents the truth of the given statement i.e.  $C \cap P = \phi$ .

- iv) Let us choose the universal set.  
 U : The set of all complex numbers.  
 Let A : The set of all rational numbers.  
 B : The set of all real numbers.

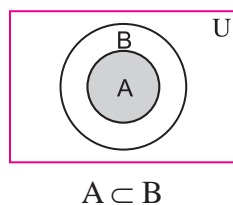

**Fig. 1.13**

The Venn diagram (fig. 1.13) represents truth of the given statement i.e.  $A \subset B$ .

- v) Let us choose the universal set.  
 U : The set of all human beings.  
 Let G : The set of all servants.  
 C : The set of all graduate people.

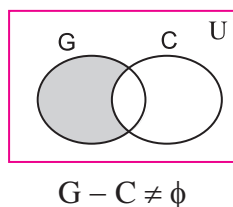

**Fig. 1.14**

The Venn diagram (fig. 1.14) represents truth of the given statement i.e.  $G - C \neq \phi$ .

- vi) Let us choose the universal set.  
 U : The set of all real numbers.  
 Let Q : The set of all rational numbers.  
 I : The set of all integers.

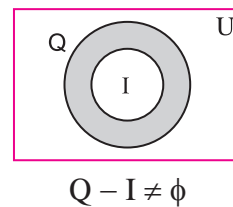

**Fig. 1.15**

The Venn diagram (fig. 1.15) represents truth of the given statement i.e.  $Q - I \neq \phi$  shaded portion.

- vii) Let us choose the universal set.  
 U : The set of all equations.  
 Let A : The set of all quadratic equations.  
 B : The set of all quadratic equations having equal roots.

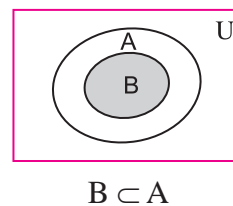

**Fig. 1.16**

The Venn diagram (fig. 1.16) represents the truth of the given statement i.e.  $B \subset A$ .

- viii) Let us choose the universal set.  
 U : The set of all complex numbers.  
 Let N : The set of all natural numbers.  
 R : The set of all real numbers.

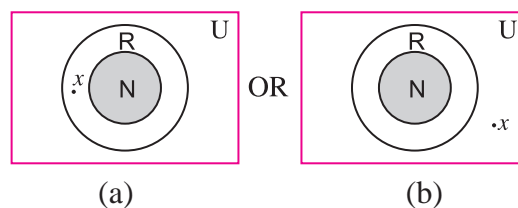

**Fig. 1.17**

The Venn diagram (fig. 1.17) represents the truth of the given statement.

**Ex. 2:** Draw the Venn diagram for the truth of the following statements.

- i) There are students who are not scholars.
- ii) There are scholars who are students.
- iii) There are persons who are students and scholars.

**Solution:**

Let us choose the universal set.

U : The set of all human beings.

Let S : The set of all scholars.

T : The set of all students.

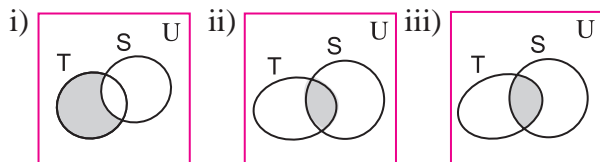

**Fig. 1.18**

We observe that (by Venn diagram) truth set of statements (ii) and (iii) are equal. Hence, statements (ii) and (iii) are logically equivalent.

**Ex. 3:** Using the Venn diagram, examine the logical equivalence of the following statements.

- i) Some politicians are actors.
- ii) There are politicians who are actors.
- iii) There are politicians who are not actors.

**Solution:**

Let us choose the universal set.

U : The set of all human beings.

Let P : The set of all politicians.

A : The set of all actors.

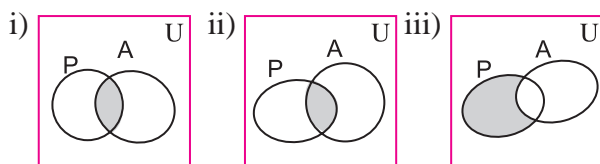

**Fig. 1.19**

By Venn diagrams (fig. 1.19), we observe that truth set of statements (i) and (ii) are equal.

Hence, statements (i) and (ii) are logically equivalent.

### EXERCISE 1.10

1. Represent the truth of each of the following statements by Venn diagrams.
  - i) Some hardworking students are obedient.
  - ii) No circles are polygons.
  - iii) All teachers are scholars and scholars are teachers.
  - iv) If a quadrilateral is a rhombus, then it is a parallelogram.
2. Draw a Venn diagram for the truth of each of the following statements.
  - i) Some sharebrokers are chartered accountants.
  - ii) No wicket keeper is bowler, in a cricket team.
3. Represent the following statements by Venn diagrams.
  - i) Some non resident Indians are not rich.
  - ii) No circle is rectangle.
  - iii) If  $n$  is a prime number and  $n \neq 2$ , then it is odd.



### Let's Remember

1. **Statement:** Declarative sentence which is either true or false, but not both simultaneously.
  - \* Imperative, exclamatory, interrogative and open sentences are not statements.
  - \* The symbol ' $\forall$ ' stands for "all values of". It is universal quantifier.
  - \* The symbol ' $\exists$ ' stands for "there exists". It is known as existential quantifier.
  - \* An open sentence with a quantifier becomes a quantified statement.

## 2. Logical connectives:

Sr. No.	Name of the Compound statement	Connective	Symbolic form	Negation
1.	Conjunction	and	$p \wedge q$	$\sim p \vee \sim q$
2.	Disjunction	or	$p \vee q$	$\sim p \wedge \sim q$
3.	Negation	not	$\sim p$	$\sim(\sim p)$ $= p$
4.	Conditional or implication	If ... then	$p \rightarrow q$ or $p \Rightarrow q$	$p \wedge \sim q$
5.	Biconditional or double implication	If and only if ... iff ...	$p \leftrightarrow q$ (or $p \Leftrightarrow q$ )	$(p \wedge \sim q) \vee$ $(\sim p \wedge q)$

**3. Tautology:** A statement pattern which is always true (T) is called a tautology (t).

**Contradiction:** A statement pattern which is always false (F) is called a contradiction (c).

**Contingency :** A statement pattern which is neither a tautology nor contradiction is called a contingency.

## 4. Algebra of statements :

(Some standard equivalent statements)

1.	$p \vee p \equiv p$	Idempotent laws	$p \wedge p \equiv p$
2.	$p \vee (q \vee r)$ $\equiv (p \vee q) \vee r$ $\equiv p \vee q \vee r$	Associative laws	$p \wedge (q \wedge r)$ $\equiv (p \wedge q) \wedge r$ $\equiv p \wedge q \wedge r$
3.	$p \vee q \equiv q \vee p$	Commutative laws	$p \wedge q \equiv q \wedge p$
4.	$p \vee (q \wedge r)$ $\equiv (p \vee q) \wedge (p \vee r)$	Distributive laws	$p \wedge (q \vee r)$ $\equiv (p \wedge q) \vee (p \wedge r)$
5.	$p \vee c \equiv p$ $p \vee t \equiv t$	Identity laws	$p \wedge c \equiv c$ $p \wedge t \equiv p$
6.	$p \vee \sim p \equiv t$ $\sim t \equiv c$	Complement laws	$p \wedge \sim p \equiv c$ $\sim c \equiv t$
7.	$\sim(\sim p) \equiv p$	Involution law (law of double negation)	
8.	$\sim(p \vee q)$ $\equiv \sim p \wedge \sim q$	DeMorgan's laws	$\sim(p \wedge q)$ $\equiv \sim p \vee \sim q$
9.	$p \rightarrow q$ $\equiv \sim q \rightarrow \sim p$	Contrapositive law	

- i)  $p \rightarrow q \equiv \sim q \rightarrow \sim p \equiv \sim p \vee q$   
 ii)  $p \leftrightarrow q \equiv (p \rightarrow q) \wedge (q \rightarrow p) \equiv (\sim p \vee q) \wedge (\sim q \vee p)$

**5. Venn-diagrams :**

- i) All x's are y's

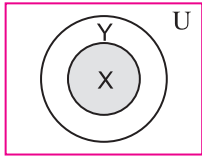

$X \cap Y = X \neq \phi$

- ii) "No x's are y's"

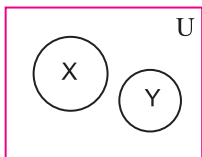

or

$X \cap Y = \phi$

- iii) "Some x's are y's"

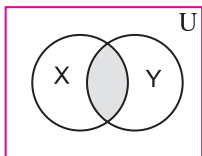

$X \cap Y \neq \phi$

or

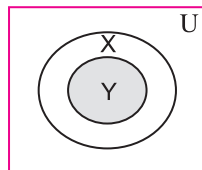

$X \cap Y = Y \neq \phi$

- iv) "Some x's are not y's"

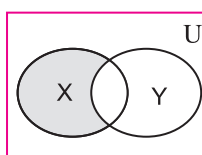

$X - Y \neq \phi$

or

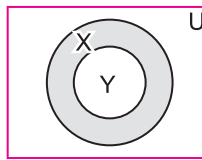

$X - Y \neq \phi$

**MISCELLANEOUS EXERCISE - 1**

**I) Choose the correct alternative.**

1. Which of the following is not a statement?  
 a) Smoking is injurious to health.  
 b)  $2 + 2 = 4$ .  
 c) 2 is the only even prime number.  
 d) Come here.

2. Which of the following is an open statement?  
 a)  $x$  is a natural number.  
 b) Give me a glass of water.  
 c) Wish you best of luck.  
 d) Good morning to all.

3. Let  $p \wedge (q \vee r) \equiv (p \wedge q) \vee (p \wedge r)$ . Then, this law is known as.  
 a) commutative law  
 b) associative law  
 c) De-Morgan's law  
 d) distributive law.

4. The false statement in the following is  
 a)  $p \wedge (\sim p)$  is contradiction  
 b)  $(p \rightarrow q) \leftrightarrow (\sim q \rightarrow \sim p)$  is a contradiction.  
 c)  $\sim(\sim p) \leftrightarrow p$  is a tautology  
 d)  $p \vee (\sim p) \leftrightarrow p$  is a tautology

5. For the following three statements  
 $p$  : 2 is an even number.  
 $q$  : 2 is a prime number.  
 $r$  : Sum of two prime numbers is always even.

Then, the symbolic statement  $(p \wedge q) \rightarrow \sim r$  means.

- a) 2 is an even and prime number and the sum of two prime numbers is always even.  
 b) 2 is an even and prime number and the sum of two prime numbers is not always even.  
 c) If 2 is an even and prime number, then the sum of two prime numbers is not always even.  
 d) If 2 is an even and prime number, then the sum of two prime numbers is also even.

6. If  $p$  : He is intelligent.  
 $q$  : He is strong  
 Then, symbolic form of statement “It is wrong that, he is intelligent or strong” is
- a)  $\sim p \vee \sim p$       b)  $\sim (p \wedge q)$   
 c)  $\sim (p \vee q)$       d)  $p \vee \sim q$
7. The negation of the proposition “If 2 is prime, then 3 is odd”, is
- a) If 2 is not prime, then 3 is not odd.  
 b) 2 is prime and 3 is not odd.  
 c) 2 is not prime and 3 is odd.  
 d) If 2 is not prime, then 3 is odd.
8. The statement  $(\sim p \wedge q) \vee \sim q$  is
- a)  $p \vee q$       b)  $p \wedge q$   
 c)  $\sim (p \vee q)$       d)  $\sim (p \wedge q)$
9. Which of the following is always true?
- a)  $(p \rightarrow q) \equiv \sim q \rightarrow \sim p$   
 b)  $\sim (p \vee q) \equiv \sim p \vee \sim q$   
 c)  $\sim (p \rightarrow q) \equiv p \wedge \sim q$   
 d)  $\sim (p \vee q) \equiv \sim p \wedge \sim q$
10.  $\sim (p \vee q) \vee (\sim p \wedge q)$  is logically equivalent to
- a)  $\sim p$       b)  $p$   
 c)  $q$       d)  $\sim q$
11. If  $p$  and  $q$  are two statements then  $(p \rightarrow q) \leftrightarrow (\sim q \rightarrow \sim p)$  is
- a) contradiction  
 b) tautology  
 c) Neither (i) nor (ii)  
 d) None of these
12. If  $p$  is the sentence ‘This statement is false’ then
- a) truth value of  $p$  is T  
 b) truth value of  $p$  is F  
 c)  $p$  is both true and false  
 d)  $p$  is neither true nor false.
13. Conditional  $p \rightarrow q$  is equivalent to
- a)  $p \rightarrow \sim q$   
 b)  $\sim p \vee q$   
 c)  $\sim p \rightarrow \sim q$   
 d)  $p \vee \sim q$
14. Negation of the statement “This is false or That is true” is
- a) That is true or This is false  
 b) That is true and This is false  
 c) That is true and That is false  
 d) That is false and That is true
15. If  $p$  is any statement then  $(p \vee \sim p)$  is a
- a) contingency  
 b) contradiction  
 c) tautology  
 d) None of them.

## II) Fill in the blanks:

- i) The statement  $q \rightarrow p$  is called as the \_\_\_\_\_ of the statement  $p \rightarrow q$ .
- ii) Conjunction of two statement  $p$  and  $q$  is symbolically written as \_\_\_\_\_.
- iii) If  $p \vee q$  is true then truth value of  $\sim p \vee \sim q$  is \_\_\_\_\_.
- iv) Negation of “some men are animal” is \_\_\_\_\_.
- v) Truth value of if  $x = 2$ , then  $x^2 = -4$  is \_\_\_\_\_.
- vi) Inverse of statement pattern  $p \leftrightarrow q$  is given by \_\_\_\_\_.
- vii)  $p \leftrightarrow q$  is false when  $p$  and  $q$  have \_\_\_\_\_ truth values.



- viii) Let  $p$  : the problem is easy.  $r$  : It is not challenging then verbal form of  $\sim p \rightarrow r$  is \_\_\_\_\_.
- ix) Truth value of  $2 + 3 = 5$  if and only if  $-3 > -9$  is \_\_\_\_\_.

### III) State whether each is True or False:

- i) Truth value of  $2 + 3 < 6$  is F.
- ii) There are 24 months in year is a statement.
- iii)  $p \vee q$  has truth value F if both  $p$  and  $q$  has truth value F.
- iv) The negation of  $10 + 20 = 30$  is, it is false that  $10 + 20 \neq 30$ .
- v) Dual of  $(p \wedge \sim q) \vee t$  is  $(p \vee \sim q) \vee C$ .
- vi) Dual of "John and Ayub went to the forest" is "John and Ayub went to the forest".
- vii) "His birthday is on 29<sup>th</sup> February" is not a statement.
- viii)  $x^2 = 25$  is true statement.
- ix) Truth value of  $\sqrt{5}$  is not an irrational number is T.
- x)  $p \wedge t = p$ .

### IV) Solve the following:

1. State which of the following sentences are statements in logic.
- i) Ice cream Sundaes are my favourite.
- ii)  $x + 3 = 8$  ;  $x$  is variable.
- iii) Read a lot to improve your writing skill.
- iv)  $z$  is a positive number.
- v)  $(a + b)^2 = a^2 + 2ab + b^2$  for all  $a, b \in \mathbb{R}$ .
- vi)  $(2 + 1)^2 = 9$ .
- vii) Why are you sad?
- viii) How beautiful the flower is!
- ix) The square of any odd number is even.
- x) All integers are natural numbers.

- xi) If  $x$  is real number then  $x^2 \geq 0$ .
- xii) Do not come inside the room.
- xiii) What a horrible sight it was!

2. Which of the following sentences are statements? In case of a statement, write down the truth value.

- i) What is happy ending?
- ii) The square of every real number is positive.
- iii) Every parallelogram is a rhombus.
- iv)  $a^2 - b^2 = (a + b)(a - b)$  for all  $a, b \in \mathbb{R}$ .
- v) Please carry out my instruction.
- vi) The Himalayas is the highest mountain range.
- vii)  $(x - 2)(x - 3) = x^2 - 5x + 6$  for all  $x \in \mathbb{R}$ .
- viii) What are the causes of rural unemployment?
- ix)  $0! = 1$
- x) The quadratic equation  $ax^2 + bx + c = 0$  ( $a \neq 0$ ) always has two real roots.

3. Assuming the first statement  $p$  and second as  $q$ . Write the following statements in symbolic form.

- i) The Sun has set and Moon has risen.
- ii) Mona likes Mathematics and Physics.
- iii) 3 is prime number iff 3 is perfect square number.
- iv) Kavita is brilliant and brave.
- v) If Kiran drives the car, then Sameer will walk.
- vi) The necessary condition for existence of a tangent to the curve of the function is continuity.
- vii) To be brave is necessary and sufficient condition to climb the Mount Everest.
- viii)  $x^3 + y^3 = (x + y)^3$  iff  $xy = 0$ .
- ix) The drug is effective though it has side effects.

- x) If a real number is not rational, then it must be irrational.
- xi) It is not true that Ram is tall and handsome.
- xii) Even though it is not cloudy, it is still raining.
- xiii) It is not true that intelligent persons are neither polite nor helpful.
- xiv) If the question paper is not easy then we shall not pass.
4. If  $p$  : Proof is lengthy.  
 $q$  : It is interesting.  
 Express the following statements in symbolic form.
- i) Proof is lengthy and it is not interesting.
- ii) If proof is lengthy then it is interesting.
- iii) It is not true that the proof is lengthy but it is interesting.
- iv) It is interesting iff the proof is lengthy.
5. Let  $p$  : Sachin wins the match.  
 $q$  : Sachin is a member of Rajya Sabha.  
 $r$  : Sachin is happy.  
 Write the verbal statement for each of the followings.
- i)  $(p \wedge q) \vee r$       ii)  $p \rightarrow r$
- iii)  $\sim p \vee q$       iv)  $p \rightarrow (p \wedge r)$
- v)  $p \rightarrow q$       vi)  $(p \wedge q) \wedge \sim r$
- vii)  $\sim (p \vee q) \wedge r$
6. Determine the truth value of the following statements.
- i)  $4 + 5 = 7$  or  $9 - 2 = 5$
- ii) If  $9 > 1$  then  $x^2 - 2x + 1 = 0$  for  $x = 1$
- iii)  $x + y = 0$  is the equation of a straight line if and only if  $y^2 = 4x$  is the equation of the parabola.
- iv) It is not true that  $2 + 3 = 6$  or  $12 + 3 = 5$
7. Assuming the following statements.  
 $p$  : Stock prices are high.  
 $q$  : Stocks are rising.  
 to be true, find the truth value of the following.
- i) Stock prices are not high or stocks are rising.
- ii) Stock prices are high and stocks are rising if and only if stock prices are high.
- iii) If stock prices are high then stocks are not rising.
- iv) It is false that stocks are rising and stock prices are high.
- v) Stock prices are high or stocks are not rising iff stocks are rising.
8. Rewrite the following statements without using conditional –  
 (Hint :  $p \rightarrow q \equiv \sim p \vee q$ )
- i) If price increases, then demand falls.
- ii) If demand falls, then price does not increase.
9. If  $p, q, r$  are statements with truth values T, T, F respectively determine the truth values of the following.
- i)  $(p \wedge q) \rightarrow \sim p$
- ii)  $p \leftrightarrow (q \rightarrow \sim p)$
- iii)  $(p \wedge \sim q) \vee (\sim p \wedge q)$
- iv)  $\sim (p \wedge q) \rightarrow \sim (q \wedge p)$
- v)  $\sim [(p \rightarrow q) \leftrightarrow (p \wedge \sim q)]$
10. Write the negation of the following.
- i) If  $\Delta ABC$  is not equilateral, then it is not equiangular.
- ii) Ramesh is intelligent and he is hard working.
- iii) An angle is a right angle if and only if it is of measure  $90^\circ$ .

- iv) Kanchanganga is in India and Everest is in Nepal.
- v) If  $x \in A \cap B$ , then  $x \in A$  and  $x \in B$ .
11. Construct the truth table for each of the following statement pattern.
- $(p \wedge \sim q) \leftrightarrow (q \rightarrow p)$
  - $(\sim p \vee q) \wedge (\sim p \wedge \sim q)$
  - $(p \wedge r) \rightarrow (p \vee \sim q)$
  - $(p \vee r) \rightarrow \sim (q \wedge r)$
  - $(p \vee \sim q) \rightarrow (r \wedge p)$
12. What is tautology? What is contradiction? Show that the negation of a tautology is a contradiction and the negation of a contradiction is a tautology.
13. Determine whether following statement pattern is a tautology, contradiction, or contingency.
- $[(p \wedge q) \vee (\sim p)] \vee [p \wedge (\sim q)]$
  - $[(\sim p \wedge q) \wedge (q \wedge r)] \vee (\sim q)$
  - $[\sim (p \vee q) \rightarrow p] \leftrightarrow [(\sim p) \wedge (\sim q)]$
  - $[\sim (p \wedge q) \rightarrow p] \leftrightarrow [(\sim p) \wedge (\sim q)]$
  - $[p \rightarrow (\sim q \vee r)] \leftrightarrow \sim [p \rightarrow (q \rightarrow r)]$
14. Using the truth table, prove the following logical equivalences.
- $p \wedge (q \vee r) \equiv (p \wedge q) \vee (p \wedge r)$
  - $[\sim (p \vee q) \vee (p \vee q)] \wedge r \equiv r$
  - $p \wedge (\sim p \vee q) \equiv p \wedge q$
  - $p \leftrightarrow q \equiv \sim (p \wedge \sim q) \wedge \sim (q \wedge \sim p)$
  - $\sim p \wedge q \equiv (p \vee q) \wedge \sim p$
15. Write the converse, inverse, contrapositive of the following statements.
- If  $2 + 5 = 10$ , then  $4 + 10 = 20$ .
  - If a man is bachelor, then he is happy.
  - If I do not work hard, then I do not prosper.
16. State the dual of each of the following statements by applying the principle of duality.
- $(p \wedge \sim q) \vee (\sim p \wedge q) \equiv (p \vee q) \wedge \sim (p \wedge q)$
  - $p \vee (q \vee r) \equiv \sim [(p \wedge q) \vee (r \vee s)]$
  - 2 is even number or 9 is a perfect square.
17. Rewrite the following statements without using the connective 'If ... then'.
- If a quadrilateral is rhombus then it is not a square.
  - If  $10 - 3 = 7$  then  $10 \times 3 \neq 30$ .
  - If it rains then the principal declares a holiday.
18. Write the dual of each of the following.
- $(\sim p \wedge q) \vee (p \wedge \sim q) \vee (\sim p \wedge \sim q)$
  - $(p \wedge q) \wedge r \equiv p \wedge (q \wedge r)$
  - $p \vee (q \wedge r) \equiv (p \vee q) \wedge (q \vee r)$
  - $\sim (p \vee q) \equiv \sim p \wedge \sim q$
19. Consider the following statements.
- If D is dog, then D is very good.
  - If D is very good, then D is dog.
  - If D is not very good, then D is not a dog.
  - If D is not a dog, then D is not very good.
- Identify the pairs of statements having the same meaning. Justify.
20. Express the truth of each of the following statements by Venn diagrams.
- All men are mortal.
  - Some persons are not politician.
  - Some members of the present Indian cricket are not committed.
  - No child is an adult.

21. If  $A = \{2, 3, 4, 5, 6, 7, 8\}$ , determine the truth value of each of the following statements.

- i)  $\exists x \in A$ , such that  $3x + 2 > 9$ .
- ii)  $\forall x \in A$ ,  $x^2 < 18$ .
- iii)  $\exists x \in A$ , such that  $x + 3 < 11$ .
- iv)  $\forall x \in A$ ,  $x^2 + 2 \geq 5$ .

22. Write the negation of the following statements.

- i) 7 is prime number and Tajmahal is in Agra.
- ii)  $10 > 5$  and  $3 < 8$ .
- iii) I will have tea or coffee.
- iv)  $\forall n \in \mathbb{N}$ ,  $n + 3 > 9$ .
- v)  $\exists x \in A$ , such that  $x + 5 < 11$ .

### Activities

1 : Complete truth table for  $\sim[p \vee (\sim q)] \equiv \sim p \wedge q$ ; Justify it.

$p$	$q$	$\sim p$	$\sim q$	$p \vee \sim q$	$\sim [p \vee (\sim q)]$	$\sim p \wedge q$
1	2	3	4	5	6	7
T	T	<input type="checkbox"/>	F	<input type="checkbox"/>	<input type="checkbox"/>	F
<input type="checkbox"/>	F	F	<input type="checkbox"/>	<input type="checkbox"/>	<input type="checkbox"/>	<input type="checkbox"/>
F	<input type="checkbox"/>	<input type="checkbox"/>	F	<input type="checkbox"/>	<input type="checkbox"/>	F
F	F	T	<input type="checkbox"/>	T	<input type="checkbox"/>	<input type="checkbox"/>

Justification : -----

2: If  $p \leftrightarrow q$  and  $p \rightarrow q$  both are true then find truth values of following with the help of activity.

- i)  $p \vee q$
- ii)  $p \wedge q$

$p \leftrightarrow q$  and  $p \rightarrow q$  are true if  $p$  and  $q$  has truth values ,  or ,

- i)  $p \vee q$ 
  - a) If both  $p$  and  $q$  are true, then  $p \vee q = \text{} \vee \text{} = \text{}$
  - b) If both  $p$  and  $q$  are false, then  $p \vee q = \text{} \vee \text{} = \text{}$
- ii)  $p \wedge q$ 
  - a) -----
  - b) -----

3 : Represent following statement by Venn diagram.

- i) Many students are not hard working.

- ii) Some students are hard working.
- iii) Sunday implies holiday.

4: You have given following statements.

$p : 9 \times 5 = 45$

$q : \text{Pune is in Maharashtra.}$

$r : 3 \text{ is smallest prime number.}$

Then write truth values by activity.

- i)  $(p \wedge q) \wedge r = (\text{} \wedge \text{}) \wedge \text{}$   
 $= \text{} \wedge \text{}$   
 $= \text{}$
- ii)  $\sim [p \wedge r] = \sim (\text{} \wedge \text{})$   
 $= \sim \text{}$   
 $= \text{}$
- iii)  $p \rightarrow q = \text{} \rightarrow \text{}$   
 $= \text{}$
- iv)  $p \leftrightarrow r = \text{} \leftrightarrow \text{}$   
 $= \text{}$





### Let's Study

- Types of Matrices
- Algebra of Matrices
- Properties of Matrices
- Elementary Transformation
- Inverse of Matrix
- Application of Matrices



### Let's Recall

#### 2.1 Introduction:

The theory of matrices was developed by the mathematician Arthur Cayley. Matrices are useful in expressing numerical information in a compact form. They are effectively used in expressing different operations. Hence they are essential in economics, finance, business and statistics.

**Definition:** A rectangular arrangement of  $mn$  numbers in  $m$  rows and  $n$  columns, enclosed in [ ] or ( ) is called a matrix of order  $m$  by  $n$ . A matrix by itself does not have a value or any special meaning.

The order of a matrix is denoted by  $m \times n$ , read as  $m$  by  $n$ .

Each member of a matrix is called an element of the matrix.

Matrices are generally denoted by capital letters like A, B, C, .... and their elements are denoted by small letters like  $a_{ij}$ ,  $b_{ij}$ ,  $c_{ij}$ , ..... etc. where  $a_{ij}$  is the element in  $i^{\text{th}}$  row and  $j^{\text{th}}$  column of the matrix A.

**For example:** i)  $A = \begin{bmatrix} 2 & -3 & 9 \\ 1 & 0 & -7 \\ 4 & -2 & 1 \end{bmatrix}$  here  $a_{32} = -2$

A is a matrix having 3 rows and 3 columns. The order of A is  $3 \times 3$ . There are 9 elements in the matrix A.

ii)  $B = \begin{bmatrix} -1 & -5 \\ 2 & 6 \\ 0 & 9 \end{bmatrix}$

B is a matrix having 3 rows and 2 columns. The order of B is  $3 \times 2$ . There are 6 elements in the matrix B.

In general, a matrix of order  $m \times n$  is represented by

$$A = [a_{ij}]_{m \times n} = \begin{bmatrix} a_{11} & a_{12} & \dots & a_{1j} & \dots & a_{1n} \\ a_{21} & a_{22} & \dots & a_{2j} & \dots & a_{2n} \\ a_{31} & a_{32} & \dots & a_{3j} & \dots & a_{3n} \\ \dots & \dots & \dots & \dots & \dots & \dots \\ \dots & \dots & \dots & \dots & \dots & \dots \\ a_{m1} & a_{m2} & \dots & a_{mj} & \dots & a_{mn} \end{bmatrix}$$

Here  $a_{ij}$  = The element in  $i^{\text{th}}$  row and  $j^{\text{th}}$  column.

Ex. In matrix  $A = \begin{bmatrix} 2 & -3 & 9 \\ 1 & 0 & -7 \\ 4 & -2 & 1 \end{bmatrix} = \begin{bmatrix} a_{11} & a_{12} & a_{13} \\ a_{21} & a_{22} & a_{23} \\ a_{31} & a_{32} & a_{33} \end{bmatrix}$

$a_{11} = 2, a_{12} = -3, a_{13} = 9, a_{21} = 1, a_{22} = 0, a_{23} = -7, a_{31} = 4, a_{32} = -2, a_{33} = 1$

## 2.2 Types of Matrices:

1) **Row Matrix** : A matrix that has only one row is called a row matrix. It is of order  $1 \times n$ , where  $n \geq 1$ .

**For example:** i)  $[-1 \ 2]_{1 \times 2}$  ii)  $[9 \ 0 \ -3]_{1 \times 3}$

2) **Column Matrix**: A matrix that has only one column is called a column matrix. It is of order  $m \times 1$ , where  $m \geq 1$ .

**For example:** i)  $\begin{bmatrix} 1 \\ 0 \end{bmatrix}_{2 \times 1}$  ii)  $\begin{bmatrix} 5 \\ -9 \\ -3 \end{bmatrix}_{3 \times 1}$

**Note:** A real number can be treated as a matrix of order  $1 \times 1$ . It is called a singleton matrix.

3) **Zero or Null Matrix** : A matrix in which every element is zero is called a zero or null matrix. It is denoted by O.

**For example:**  $O = \begin{bmatrix} 0 & 0 \\ 0 & 0 \\ 0 & 0 \end{bmatrix}_{3 \times 2}$

4) **Square Matrix** : A matrix with the number of rows equal to the number of columns is called a square matrix. If a square matrix is of order  $n \times n$  then  $n$  is called the order of the square matrix.

**For example:**  $A = \begin{bmatrix} 5 & -3 & i \\ 1 & 0 & -7 \\ 2i & -8 & 9 \end{bmatrix}_{3 \times 3}$

**Let's Note:** Let  $A = [a_{ij}]_{n \times n}$  be a square matrix of order  $n$ , Then

- (i) the elements  $a_{11}, a_{22}, a_{33}, \dots, a_{ii}, \dots, a_{nn}$  are called the diagonal elements of the matrix A. Note that the diagonal elements are defined only for a square matrix;
- (ii) elements  $a_{ij}$ , where  $i \neq j$  are called non diagonal elements of the matrix A;

(iii) elements  $a_{ij}$ , where  $i < j$ , are called elements above the diagonal;

(iv) elements  $a_{ij}$ , where  $i > j$ , are called elements below the diagonal.

Statements iii) and iv) are to be verified by looking at matrices of different orders.

**5) Diagonal Matrix:** A square matrix in which every non-diagonal element is zero, is called a diagonal matrix.

**For example:** i)  $A = \begin{bmatrix} 5 & 0 & 0 \\ 0 & 0 & 0 \\ 0 & 0 & 0 \end{bmatrix}_{3 \times 3}$       ii)  $B = \begin{bmatrix} -1 & 0 \\ 0 & -5 \end{bmatrix}_{2 \times 2}$

**Note :** If  $a_{11}$ ,  $a_{22}$ ,  $a_{33}$  are diagonal elements of a diagonal matrix A of order 3, then we write the matrix A as  $A = \text{Diag}[a_{11}, a_{22}, a_{33}]$ .

**6) Scalar Matrix:** A diagonal matrix in which all the diagonal elements are same is called a scalar matrix.

**For example:**  $A = \begin{bmatrix} 5 & 0 & 0 \\ 0 & 5 & 0 \\ 0 & 0 & 5 \end{bmatrix}_{3 \times 3}$

**7) Unit or Identity Matrix :** A scalar matrix in which all the diagonal elements are 1 (unity), is called a Unit Matrix or an Identity Matrix. Identity Matrix of order n is denoted by  $I_n$ .

**For example:**  $I_3 = \begin{bmatrix} 1 & 0 & 0 \\ 0 & 1 & 0 \\ 0 & 0 & 1 \end{bmatrix}$

**Note :**

1. Every Identity Matrix is a scalar matrix but every scalar matrix need not be Identity Matrix. However a scalar matrix is a scalar multiple of the identity matrix.
2. Every scalar matrix is diagonal matrix but every diagonal matrix need not be scalar matrix.

**8) Upper Triangular Matrix:** A square matrix in which every element below the diagonal is zero is called an upper triangular matrix.

Matrix  $A = [a_{ij}]_{n \times n}$  is upper triangular if  $a_{ij} = 0$  for all  $i > j$ .

**For example:** i)  $A = \begin{bmatrix} 4 & -1 & 2 \\ 0 & 0 & 3 \\ 0 & 0 & 9 \end{bmatrix}_{3 \times 3}$

**9) Lower Triangular Matrix:** A square matrix in which every element above the diagonal is zero, is called a lower triangular matrix.

Matrix  $A = [a_{ij}]_{n \times n}$  is lower triangular if  $a_{ij} = 0$  for all  $i < j$ .

**For example:**  $A = \begin{bmatrix} 2 & 0 & 0 \\ -1 & 0 & 0 \\ -5 & 1 & 9 \end{bmatrix}_{3 \times 3}$

**10) Triangular Matrix:** A square matrix is called a triangular matrix if it is an upper triangular or a lower triangular matrix.

**Note:** The diagonal, scalar, unit and square null matrices are also triangular matrices.

**(11) Determinant of a Matrix:** Determinant of a matrix is defined only for a square matrix.

If A is a square matrix, then the same arrangement of the elements of A also gives us a determinant. It is denoted by  $|A|$  or  $\det(A)$ .

If  $A = [a_{ij}]_{n \times n}$  then  $|A|$  is of order n.

**For example:** i) If  $A = \begin{bmatrix} 1 & 3 \\ -5 & 4 \end{bmatrix}_{2 \times 2}$  then  $|A| = \begin{vmatrix} 1 & 3 \\ -5 & 4 \end{vmatrix}$

ii) If  $B = \begin{bmatrix} 2 & -1 & 3 \\ -4 & 1 & 5 \\ 7 & -5 & 0 \end{bmatrix}_{3 \times 3}$  then  $|B| = \begin{vmatrix} 2 & -1 & 3 \\ -4 & 1 & 5 \\ 7 & -5 & 0 \end{vmatrix}$

**12) Singular Matrix :** A square matrix A is said to be a singular matrix if

$|A| = \det(A) = 0$ . Otherwise, it is said to be a non-singular matrix.

**For example:** i) If  $B = \begin{bmatrix} 2 & 3 & 4 \\ 3 & 4 & 5 \\ 4 & 5 & 6 \end{bmatrix}_{3 \times 3}$  then  $|B| = \begin{vmatrix} 2 & 3 & 4 \\ 3 & 4 & 5 \\ 4 & 5 & 6 \end{vmatrix}$

$$\begin{aligned} |B| &= 2(24 - 25) - 3(18 - 20) + 4(15 - 16) \\ &= -2 + 6 - 4 \\ &= 0 \end{aligned}$$

$$|B| = 0$$

Therefore B is a singular matrix.

ii)  $A = \begin{bmatrix} 2 & -1 & 3 \\ -7 & 4 & 5 \\ -2 & 1 & 6 \end{bmatrix}_{3 \times 3}$  Then  $|A| = \begin{vmatrix} 2 & -1 & 3 \\ -7 & 4 & 5 \\ -2 & 1 & 6 \end{vmatrix}$

$$\begin{aligned} |A| &= 2(24 - 5) - (-1)(-42 + 10) + 3(-7 + 8) \\ &= 38 - 32 + 3 \\ &= 9 \end{aligned}$$

$$|A| = 9$$

As  $|A| \neq 0$ , A is a non-singular matrix.



## SOLVED EXAMPLES

**Ex.** 1) Show that the matrix  $\begin{bmatrix} x+y & y+z & z+x \\ 1 & 1 & 1 \\ z & x & y \end{bmatrix}$  is a singular matrix.

Solution : Let  $A = \begin{bmatrix} x+y & y+z & z+x \\ 1 & 1 & 1 \\ z & x & y \end{bmatrix}$

$$\therefore |A| = \begin{vmatrix} x+y & y+z & z+x \\ 1 & 1 & 1 \\ z & x & y \end{vmatrix}$$

$$\begin{aligned} \text{Now } |A| &= (x+y)(y-x) - (y+z)(y-z) + (z+x)(x-z) \\ &= y^2 - x^2 - y^2 + z^2 + x^2 - z^2 \\ &= 0 \end{aligned}$$

$\therefore A$  is a singular matrix.

## EXERCISE 2.1

(1) Construct a matrix  $A = [a_{ij}]_{3 \times 2}$  whose element  $a_{ij}$  is given by

(i)  $a_{ij} = \frac{(i-j)^2}{5-i}$       (ii)  $a_{ij} = i - 3j$       (iii)  $a_{ij} = \frac{(i+j)^3}{5}$

(2) Classify each of the following matrices as a row, a column, a square, a diagonal, a scalar, a unit, an upper triangular, a lower triangular matrix.

(i)  $\begin{bmatrix} 3 & -2 & 4 \\ 0 & 0 & -5 \\ 0 & 0 & 0 \end{bmatrix}$       (ii)  $\begin{bmatrix} 5 \\ 4 \\ -3 \end{bmatrix}$       (iii)  $\begin{bmatrix} 9 & \sqrt{2} & -3 \end{bmatrix}$       (iv)  $\begin{bmatrix} 6 & 0 \\ 0 & 6 \end{bmatrix}$

(v)  $\begin{bmatrix} 2 & 0 & 0 \\ 3 & -1 & 0 \\ -7 & 3 & 1 \end{bmatrix}$       (vi)  $\begin{bmatrix} 3 & 0 & 0 \\ 0 & 5 & 0 \\ 0 & 0 & \frac{1}{3} \end{bmatrix}$       (vii)  $\begin{bmatrix} 1 & 0 & 0 \\ 0 & 1 & 0 \\ 0 & 0 & 1 \end{bmatrix}$

(3) Which of the following matrices are singular or non singular?

(i)  $\begin{bmatrix} a & b & c \\ p & q & r \\ 2a-p & 2b-q & 2c-r \end{bmatrix}$       (ii)  $\begin{bmatrix} 5 & 0 & 5 \\ 1 & 99 & 100 \\ 6 & 99 & 105 \end{bmatrix}$

$$(iii) \begin{bmatrix} 3 & 5 & 7 \\ -2 & 1 & 4 \\ 3 & 2 & 5 \end{bmatrix}$$

$$(iv) \begin{bmatrix} 7 & 5 \\ -4 & 7 \end{bmatrix}$$

(4) Find K if the following matrices are singular.

$$(i) \begin{bmatrix} 7 & 3 \\ -2 & K \end{bmatrix}$$

$$(ii) \begin{bmatrix} 4 & 3 & 1 \\ 7 & K & 1 \\ 10 & 9 & 1 \end{bmatrix}$$

$$(iii) \begin{bmatrix} K-1 & 2 & 3 \\ 3 & 1 & 2 \\ 1 & -2 & 4 \end{bmatrix}$$

### 2.3 Algebra of Matrices:

(1) Transpose of a Matrix (2) Determinant of a Matrix (3) Equality of Matrices (4) Addition of Matrices (5) Scalar Multiplication of a Matrix and (6) Multiplication of two matrices.

**(1) Transpose of a Matrix:** A is a matrix of order  $m \times n$ . The matrix obtained by interchanging rows and columns of matrix A is called the transpose of the matrix A. It is denoted by  $A'$  or  $A^T$ . The order of  $A^T$  is  $n \times m$ .

**For example:** i) If  $A = \begin{bmatrix} -1 & 5 \\ 3 & -2 \\ 4 & 7 \end{bmatrix}_{3 \times 2}$  then  $A^T = \begin{bmatrix} -1 & 3 & 4 \\ 5 & -2 & 7 \end{bmatrix}_{2 \times 3}$

ii) If  $B = \begin{bmatrix} 1 & 0 & -2 \\ 8 & -1 & 2 \\ 4 & 3 & 5 \end{bmatrix}_{3 \times 3}$  then  $B^T = \begin{bmatrix} 1 & 8 & 4 \\ 0 & -1 & 3 \\ -2 & 2 & 5 \end{bmatrix}_{3 \times 3}$

**i) Symmetric Matrix:** A square matrix  $A = [a_{ij}]_{n \times n}$  in which  $a_{ij} = a_{ji}$ , for all i and j, is called a symmetric matrix.

**For example:**  $A = \begin{bmatrix} a & h & g \\ h & b & f \\ g & f & c \end{bmatrix}_{3 \times 3}$

**Let's Note:** The diagonal matrices are symmetric. Null square matrix is symmetric.

**ii) Skew-Symmetric Matrix:** A square matrix  $A = [a_{ij}]_{n \times n}$  in which  $a_{ij} = -a_{ji}$ , for all i and j, is called a skew symmetric matrix.

Here for  $i = j$ ,  $a_{ij} = -a_{ji}$ ,  $\therefore 2a_{ii} = 0 \quad \therefore a_{ii} = 0$  for all  $i = 1, 2, 3, \dots, n$ .

In a skew symmetric matrix, each diagonal element is zero.

**For example:**  $B = \begin{bmatrix} 0 & 4 & -7 \\ -4 & 0 & 5 \\ 7 & -5 & 0 \end{bmatrix}_{3 \times 3}$

**Let's Note:**

- 1)  $(A^T)^T = A$
- 2) If A is a symmetric matrix then  $A = A^T$
- 3) If B is a skew symmetric matrix then  $B = -B^T$
- 4) A null square matrix is also skew symmetric.
- 5)  $|A| = |A^T|$

**(3) Equality of Two matrices:** Two matrices A and B are said to be equal if (i) order of A = order of B and (ii) corresponding elements of A and B are same. That is  $a_{ij} = b_{ij}$  for all i, j. Symbolically, this is written as  $A=B$ .

**For example:** i) If  $A = \begin{bmatrix} 2 & 4 & 1 \\ -1 & 0 & 0 \end{bmatrix}_{2 \times 3}$  and  $B = \begin{bmatrix} 2 & -1 \\ 4 & 0 \\ 1 & 0 \end{bmatrix}_{3 \times 2}$

Here  $B^T = \begin{bmatrix} 2 & 4 & 1 \\ -1 & 0 & 0 \end{bmatrix}_{2 \times 3}$  In matrices A and B,  $A \neq B$ , but  $A = B^T$ .

**For example:** ii) If  $\begin{bmatrix} 2a-b & 4 \\ -7 & 2 \end{bmatrix} = \begin{bmatrix} 1 & 4 \\ -7 & a+3b \end{bmatrix}$ , then find a and b.

Using definition of equality of matrices, we have

$$2a - b = 1 \dots\dots (1) \text{ and}$$

$$a + 3b = 2 \dots\dots (2)$$

Solving equation (1) and (2), we get  $a = \frac{5}{7}$  and  $b = \frac{3}{7}$

**Let's note:** If  $A = B$ , then  $B = A$

**(4) Addition of Two Matrices:** A and B are two matrices of same order. Their addition, denoted by  $A + B$ , is a matrix obtained by adding the corresponding elements of A and B. Note that orders of A, B and  $A + B$  are same.

Thus if  $A = [a_{ij}]_{m \times n}$  and  $B = [b_{ij}]_{m \times n}$  then  $A + B = [a_{ij} + b_{ij}]_{m \times n}$

**For example:** i) If  $A = \begin{bmatrix} 2 & 3 & 1 \\ -1 & -2 & 0 \end{bmatrix}_{2 \times 3}$  and  $B = \begin{bmatrix} -4 & 3 & 1 \\ 5 & 7 & -8 \end{bmatrix}_{2 \times 3}$  find  $A + B$ .

**Solution:** Since A and B have same order,  $A + B$  is defined and

$$A + B = \begin{bmatrix} 2+(-4) & 3+3 & 1+1 \\ -1+5 & -2+7 & 0+(-8) \end{bmatrix}_{2 \times 3} = \begin{bmatrix} -2 & 6 & 2 \\ 4 & 5 & -8 \end{bmatrix}_{2 \times 3}$$

**Let's Note:** If A and B are two matrices of same order then subtraction of two matrices is defined as,  $A - B = A + (-B)$ , where  $-B$  is the negative of matrix B.

**For example:** i) If  $A = \begin{bmatrix} -1 & 4 \\ 3 & -2 \\ 0 & 5 \end{bmatrix}_{3 \times 2}$  and  $B = \begin{bmatrix} -1 & 5 \\ 2 & -6 \\ 4 & 9 \end{bmatrix}_{3 \times 2}$ , Find  $A - B$ .

**Solution:** Since A and B have same order,  $A - B$  is defined and

$$A - B = A + (-B) = \begin{bmatrix} -1 & 4 \\ 3 & -2 \\ 0 & 5 \end{bmatrix}_{3 \times 2} - \begin{bmatrix} -1 & 5 \\ 2 & -6 \\ 4 & 9 \end{bmatrix}_{3 \times 2} = \begin{bmatrix} -1+1 & 4+(-5) \\ 3+(-2) & -2+6 \\ 0+(-4) & 5+(-9) \end{bmatrix} = \begin{bmatrix} 0 & -1 \\ 1 & 4 \\ -4 & -4 \end{bmatrix}$$

**(5) Scalar Multiplication of a Matrix:** If A is any matrix and k is a scalar, then the matrix obtained by multiplying each element of A by the scalar k is called the scalar multiple of the matrix A and is denoted by  $kA$ .

Thus if  $A = [a_{ij}]_{m \times n}$  and k is any scalar then  $kA = [ka_{ij}]_{m \times n}$ .

Here the orders of matrices A and  $kA$  are same.

**For example:** i) If  $A = \begin{bmatrix} -1 & 5 \\ 3 & -2 \\ 4 & 7 \end{bmatrix}_{3 \times 2}$  and  $k = \frac{3}{2}$ , then  $kA$ .

$$\frac{3}{2} A = \frac{3}{2} \begin{bmatrix} -1 & 5 \\ 3 & -2 \\ 4 & 7 \end{bmatrix}_{3 \times 2} = \begin{bmatrix} -\frac{3}{2} & \frac{15}{2} \\ \frac{9}{2} & -3 \\ 6 & \frac{21}{2} \end{bmatrix}_{3 \times 2}$$

**Properties of addition and scalar multiplication:** If A, B, C are three matrices conformable for addition and  $\alpha, \beta$  are scalars, then

- (i)  $A + B = B + A$ , that is, the matrix addition is commutative.
- (ii)  $(A + B) + C = A + (B + C)$ , that is, the matrix addition is associative.
- (iii) For matrix A, we have  $A + O = O + A = A$ , that is, zero matrix is conformable for addition and it is the identity for matrix addition.
- (iv) For a matrix A, we have  $A + (-A) = (-A) + A = O$ , where O is zero matrix conformable with the matrix A for addition.
- (v)  $\alpha(A \pm B) = \alpha A \pm \alpha B$
- (vi)  $(\alpha \pm \beta)A = \alpha A \pm \beta B$
- (vii)  $\alpha(\beta \cdot A) = (\alpha \cdot \beta) \cdot A$
- (viii)  $OA = O$

## SOLVED EXAMPLES

**Ex.** 1) If  $A = \begin{bmatrix} 5 & -3 \\ 1 & 0 \\ -4 & -2 \end{bmatrix}$  and  $B = \begin{bmatrix} 2 & 7 \\ -3 & 1 \\ 2 & -2 \end{bmatrix}$ , find  $2A - 3B$ .

**Solution:** Let  $2A - 3B = 2 \begin{bmatrix} 5 & -3 \\ 1 & 0 \\ -4 & -2 \end{bmatrix} - 3 \begin{bmatrix} 2 & 7 \\ -3 & 1 \\ 2 & -2 \end{bmatrix}$

$$= \begin{bmatrix} 10 & -6 \\ 2 & 0 \\ -8 & -4 \end{bmatrix} + \begin{bmatrix} -6 & -21 \\ 9 & -3 \\ -6 & 6 \end{bmatrix}$$

$$= \begin{bmatrix} 10-6 & -6-21 \\ 2+9 & 0-3 \\ -8-6 & -4+6 \end{bmatrix}$$

$$= \begin{bmatrix} 4 & -27 \\ 11 & -3 \\ -14 & 2 \end{bmatrix}$$

**Ex.** 2) If  $A = \text{diag}(2, -5, 9)$ ,  $B = \text{diag}(-3, 7, -14)$  and  $C = \text{diag}(1, 0, 3)$ , find  $B - A - C$ .

**Solution:**  $B - A - C = B - (A + C)$

Now,  $A + C = \text{diag}(2, -5, 9) + \text{diag}(1, 0, 3) = \text{diag}(3, -5, 12)$

$B - A - C = B - (A + C) = \text{diag}(-3, 7, -14) - \text{diag}(3, -5, 12)$

$= \text{diag}(-6, 12, -26)$

$$= \begin{bmatrix} -6 & 0 & 0 \\ 0 & 12 & 0 \\ 0 & 0 & -26 \end{bmatrix}$$

**Ex.** 3) If  $A = \begin{bmatrix} 2 & 3 & -1 \\ 4 & 7 & 5 \end{bmatrix}$ ,  $B = \begin{bmatrix} 1 & 3 & 2 \\ 4 & 6 & -1 \end{bmatrix}$  and  $C = \begin{bmatrix} 1 & -1 & 6 \\ 0 & 2 & -5 \end{bmatrix}$ , find the matrix X such that

$3A - 2B + 4X = 5C$ .

**Solution:** Since  $3A - 2B + 4X = 5C$

$\therefore 4X = 5C - 3A + 2B$

$$\therefore 4X = 5 \begin{bmatrix} 1 & -1 & 6 \\ 0 & 2 & -5 \end{bmatrix} - 3 \begin{bmatrix} 2 & 3 & -1 \\ 4 & 7 & 5 \end{bmatrix} + 2 \begin{bmatrix} 1 & 3 & 2 \\ 4 & 6 & -1 \end{bmatrix}$$

$$= \begin{bmatrix} 5 & -5 & 30 \\ 0 & 10 & -25 \end{bmatrix} + \begin{bmatrix} -6 & -9 & 3 \\ -12 & -21 & -15 \end{bmatrix} + \begin{bmatrix} 2 & 6 & 4 \\ 8 & 12 & -2 \end{bmatrix}$$

$$= \begin{bmatrix} 5-6+2 & -5-9+6 & 30+3+4 \\ 0-12+8 & 10-21+12 & -25-15-2 \end{bmatrix}$$

$$= \begin{bmatrix} 1 & -8 & 37 \\ -4 & 1 & -42 \end{bmatrix}$$

$$\therefore X = \frac{1}{4} \begin{bmatrix} 1 & -8 & 37 \\ -4 & 1 & -42 \end{bmatrix}$$

$$X = \begin{bmatrix} \frac{1}{4} & -2 & \frac{37}{4} \\ -1 & \frac{1}{4} & -\frac{21}{2} \end{bmatrix}$$

**Ex.** 4) If  $\begin{bmatrix} 2x+1 & -1 \\ 3 & 4y \end{bmatrix} + \begin{bmatrix} -1 & 6 \\ 3 & 0 \end{bmatrix} = \begin{bmatrix} 4 & 5 \\ 6 & 12 \end{bmatrix}$ , find  $x$  and  $y$ .

**Solution:** Given  $\begin{bmatrix} 2x+1 & -1 \\ 3 & 4y \end{bmatrix} + \begin{bmatrix} -1 & 6 \\ 3 & 0 \end{bmatrix} = \begin{bmatrix} 4 & 5 \\ 6 & 12 \end{bmatrix}$

$$\therefore \begin{bmatrix} 2x & 5 \\ 6 & 4y \end{bmatrix} = \begin{bmatrix} 4 & 5 \\ 6 & 12 \end{bmatrix}$$

$\therefore$  Using definition of equality of matrices, we have  $2x = 4$ ,  $4y = 12$

$$\therefore x = 2, \quad y = 3$$

**Ex.** 5) Find  $a$ ,  $b$ ,  $c$  if the matrix  $A = \begin{bmatrix} 2 & a & 3 \\ -7 & 4 & 5 \\ c & b & 6 \end{bmatrix}$  is a symmetric matrix.

**Solution:** Given that  $A = \begin{bmatrix} 2 & a & 3 \\ -7 & 4 & 5 \\ c & b & 6 \end{bmatrix}$  is a symmetric matrix.

$$\therefore a_{ij} = a_{ji} \text{ for all } i \text{ and } j$$

$$\therefore a = -7, \quad b = 5, \quad c = 3$$

**Ex. 6)** If  $A = \begin{bmatrix} -1 & -5 \\ 2 & 0 \\ 3 & -4 \end{bmatrix}_{3 \times 2}$  Find  $(A^T)^T$ .

**Solution:** Let  $A = \begin{bmatrix} -1 & -5 \\ 2 & 0 \\ 3 & -4 \end{bmatrix}_{3 \times 2}$

$$\therefore A^T = \begin{bmatrix} -1 & 2 & 3 \\ -5 & 0 & -4 \end{bmatrix}_{2 \times 3}$$

$$\begin{aligned} \text{Now } (A^T)^T &= \begin{bmatrix} -1 & -5 \\ 2 & 0 \\ 3 & -4 \end{bmatrix}_{3 \times 2} \\ &= A \end{aligned}$$

**Ex. 7)** If  $X + Y = \begin{bmatrix} 2 & -1 \\ 1 & 3 \\ -3 & -2 \end{bmatrix}$  and  $X - 2Y = \begin{bmatrix} -2 & 1 \\ 3 & -1 \\ 4 & -2 \end{bmatrix}$  then find X, Y.

**Solution:** Let  $A = \begin{bmatrix} 2 & -1 \\ 1 & 3 \\ -3 & -2 \end{bmatrix}$  and  $B = \begin{bmatrix} -2 & 1 \\ 3 & -1 \\ 4 & -2 \end{bmatrix}$

$X + Y = A$  ..... (1),  $X - 2Y = B$  ..... (2), Solving (1) and (2) for X and Y

Consider (1) - (2),  $3Y = A - B$ ,

$$\therefore Y = \frac{1}{3} (A - B)$$

$$\therefore Y = \frac{1}{3} \left\{ \begin{bmatrix} 2 & -1 \\ 1 & 3 \\ -3 & -2 \end{bmatrix} - \begin{bmatrix} -2 & 1 \\ 3 & -1 \\ 4 & -2 \end{bmatrix} \right\}$$

$$= \frac{1}{3} \begin{bmatrix} 4 & -2 \\ -2 & 4 \\ -7 & 0 \end{bmatrix}$$

$$= \begin{bmatrix} \frac{4}{3} & -\frac{2}{3} \\ -\frac{2}{3} & \frac{4}{3} \\ -\frac{7}{3} & 0 \end{bmatrix}$$

From (1)  $X + Y = A$ ,

$$\therefore X = A - Y,$$
$$\therefore X = \begin{bmatrix} 2 & -1 \\ 1 & 3 \\ -3 & -2 \end{bmatrix} - \begin{bmatrix} \frac{4}{3} & -\frac{2}{3} \\ -\frac{2}{3} & \frac{4}{3} \\ -\frac{7}{3} & 0 \end{bmatrix}$$

$$X = \begin{bmatrix} \frac{2}{3} & -\frac{1}{3} \\ \frac{5}{3} & \frac{5}{3} \\ -\frac{2}{3} & -2 \end{bmatrix}$$

### EXERCISE 2.2

(1) If  $A = \begin{bmatrix} 2 & -3 \\ 5 & -4 \\ -6 & 1 \end{bmatrix}$ ,  $B = \begin{bmatrix} -1 & 2 \\ 2 & 2 \\ 0 & 3 \end{bmatrix}$  and  $C = \begin{bmatrix} 4 & 3 \\ -1 & 4 \\ -2 & 1 \end{bmatrix}$

Show that (i)  $A + B = B + A$

(ii)  $(A + B) + C = A + (B + C)$

(2) If  $A = \begin{bmatrix} 1 & -2 \\ 5 & 3 \end{bmatrix}$ ,  $B = \begin{bmatrix} 1 & -3 \\ 4 & -7 \end{bmatrix}$ , then find the matrix  $A - 2B + 6I$ , where  $I$  is the unit matrix of order 2.

(3) If  $A = \begin{bmatrix} 1 & 2 & -3 \\ -3 & 7 & -8 \\ 0 & -6 & 1 \end{bmatrix}$ ,  $B = \begin{bmatrix} 9 & -1 & 2 \\ -4 & 2 & 5 \\ 4 & 0 & -3 \end{bmatrix}$  then find the matrix  $C$  such that  $A + B + C$  is a zero matrix.

(4) If  $A = \begin{bmatrix} 1 & -2 \\ 3 & -5 \\ -6 & 0 \end{bmatrix}$ ,  $B = \begin{bmatrix} -1 & -2 \\ 4 & 2 \\ 1 & 5 \end{bmatrix}$  and  $C = \begin{bmatrix} 2 & 4 \\ -1 & -4 \\ -3 & 6 \end{bmatrix}$ , find the matrix  $X$  such that

$$3A - 4B + 5X = C.$$

(5) If  $A = \begin{bmatrix} 5 & 1 & -4 \\ 3 & 2 & 0 \end{bmatrix}$ , find  $(A^T)^T$ .

(6) If  $A = \begin{bmatrix} 7 & 3 & 1 \\ -2 & -4 & 1 \\ 5 & 9 & 1 \end{bmatrix}$ , find  $(A^T)^T$ .



(7) Find  $a, b, c$  if  $\begin{bmatrix} 1 & \frac{3}{5} & a \\ b & -5 & -7 \\ -4 & c & 0 \end{bmatrix}$  is a symmetric matrix.

(8) Find  $x, y, z$  if  $\begin{bmatrix} 0 & -5i & x \\ y & 0 & z \\ \frac{3}{2} & -\sqrt{2} & 0 \end{bmatrix}$  is a skew symmetric matrix.

(9) For each of the following matrices, find its transpose and state whether it is symmetric, skew-symmetric or neither.

(i)  $\begin{bmatrix} 1 & 2 & -5 \\ 2 & -3 & 4 \\ -5 & 4 & 9 \end{bmatrix}$       (ii)  $\begin{bmatrix} 2 & 5 & 1 \\ -5 & 4 & 6 \\ -1 & -6 & 3 \end{bmatrix}$       (iii)  $\begin{bmatrix} 0 & 1+2i & i-2 \\ -1-2i & 0 & -7 \\ 2-i & 7 & 0 \end{bmatrix}$

(10) Construct the matrix  $A = [a_{ij}]_{3 \times 3}$  where  $a_{ij} = i - j$ . State whether  $A$  is symmetric or skew symmetric.

(11) Solve the following equations for  $X$  and  $Y$ , if  $3X - Y = \begin{bmatrix} 1 & -1 \\ -1 & 1 \end{bmatrix}$  and  $X - 3Y = \begin{bmatrix} 0 & -1 \\ 0 & -1 \end{bmatrix}$

(12) Find matrices  $A$  and  $B$ , if  $2A - B = \begin{bmatrix} 6 & -6 & 0 \\ -4 & 2 & 1 \end{bmatrix}$  and  $A - 2B = \begin{bmatrix} 3 & 2 & 8 \\ -2 & 1 & -7 \end{bmatrix}$

(13) Find  $x$  and  $y$ , if  $\begin{bmatrix} 2x+y & -1 & 1 \\ 3 & 4y & 4 \end{bmatrix} + \begin{bmatrix} -1 & 6 & 4 \\ 3 & 0 & 3 \end{bmatrix} = \begin{bmatrix} 3 & 5 & 5 \\ 6 & 18 & 7 \end{bmatrix}$

(14) If  $\begin{bmatrix} 2a+b & 3a-b \\ c+2d & 2c-d \end{bmatrix} = \begin{bmatrix} 2 & 3 \\ 4 & -1 \end{bmatrix}$ , find  $a, b, c$  and  $d$ .

(15) There are two book shops own by Suresh and Ganesh. Their sales ( in Rupees) for books in three subject - Physics, Chemistry and Mathematics for two months, July and August 2017 are given by two matrices  $A$  and  $B$ .

July sales ( in Rupees),    Physics    Chemistry    Mathematics

$$A = \begin{bmatrix} 5600 & 6750 & 8500 \\ 6650 & 7055 & 8905 \end{bmatrix} \text{ First Row Suresh / Second Row Ganesh}$$

August sales ( in Rupees),    Physics    Chemistry    Mathematics

$$B = \begin{bmatrix} 6650 & 7055 & 8905 \\ 7000 & 7500 & 10200 \end{bmatrix} \text{ First Row Suresh / Second Row Ganesh}$$

then, (i) Find the increase in sales in Rupees from July to August 2017.

(ii) If both book shops get 10% profit in the month of August 2017, find the profit for each book seller in each subject in that month.

**(6) Multiplication of Two Matrices:**

Two Matrices A and B are said to be conformable for multiplication if the number of columns in A is equal to the number of rows in B. For example, A is of order  $m \times n$  and B is of order  $n \times p$ .

In this case the elements of the product AB form a matrix defined as follows:

$$A_{m \times n} \times B_{n \times p} = C_{m \times p}, \quad \text{where } C_{ij} = \sum_{k=1}^n a_{ik} b_{kj}$$

$$\text{If } A = [a_{jk}]_{m \times n} = \begin{bmatrix} a_{11} & a_{12} & \dots & a_{1k} & \dots & a_{1n} \\ a_{21} & a_{22} & \dots & a_{2k} & \dots & a_{2n} \\ a_{31} & a_{32} & \dots & a_{3k} & \dots & a_{3n} \\ \dots & \dots & \dots & \dots & \dots & \dots \\ \dots & \dots & \dots & \dots & \dots & \dots \\ a_{m1} & a_{m2} & \dots & a_{mk} & \dots & a_{mn} \end{bmatrix} \rightarrow \text{i}^{\text{th}} \text{ row}$$

$$B = [b_{kj}]_{n \times p} = \begin{bmatrix} b_{11} & b_{12} & \dots & b_{1j} & \dots & b_{1p} \\ b_{21} & b_{22} & \dots & b_{2j} & \dots & b_{2p} \\ b_{31} & b_{32} & \dots & b_{3j} & \dots & b_{3p} \\ \dots & \dots & \dots & \dots & \dots & \dots \\ \dots & \dots & \dots & \dots & \dots & \dots \\ b_{n1} & b_{n2} & \dots & b_{nj} & \dots & b_{np} \end{bmatrix} \text{ then}$$

↓  
j<sup>th</sup> column

$$\text{then } c_{ij} = a_{i1}b_{1j} + a_{i2}b_{2j} + a_{i3}b_{3j} + \dots + a_{in}b_{nj}$$

**SOLVED EXAMPLES**

**Ex.1:** Let  $A = [a_{11} \ a_{12} \ a_{13}]_{1 \times 3}$  and  $B = \begin{bmatrix} b_{11} \\ b_{21} \\ b_{31} \end{bmatrix}_{3 \times 1}$  Find AB.

**Solution:** Since number of columns of A = number of rows of B = 3

Therefore product AB is defined and its order is 1.

$$AB = [a_{11} \times b_{11} + a_{12} \times b_{21} + a_{13} \times b_{31}]$$

**Ex.2:** Let  $A = [1 \ 3 \ 2]_{1 \times 3}$  and  $B = \begin{bmatrix} 3 \\ 2 \\ 1 \end{bmatrix}_{3 \times 1}$ , find AB. Does BA exist? If yes, find it.

**Solution:** Product AB is defined and order of AB is 1.

$$\therefore AB = \begin{bmatrix} 1 & 3 & 2 \end{bmatrix} \begin{bmatrix} 3 \\ 2 \\ 1 \end{bmatrix} = [1 \times 3 + 3 \times 2 + 2 \times 1] = [11]_{1 \times 1}$$

Again, number of column of B = number of rows of A = 1.

$\therefore$  product BA is also defined and the order of BA is 3.

$$\begin{aligned} BA &= \begin{bmatrix} 3 \\ 2 \\ 1 \end{bmatrix}_{3 \times 1} \begin{bmatrix} 1 & 3 & 2 \end{bmatrix}_{1 \times 3} \\ &= \begin{bmatrix} 3 \times 1 & 3 \times 3 & 3 \times 2 \\ 2 \times 1 & 2 \times 3 & 2 \times 2 \\ 1 \times 1 & 1 \times 3 & 1 \times 2 \end{bmatrix}_{3 \times 3} = \begin{bmatrix} 3 & 9 & 6 \\ 2 & 6 & 4 \\ 1 & 3 & 2 \end{bmatrix}_{3 \times 3} \end{aligned}$$

**Remark:** Here AB and BA both are defined but they are different matrices.

**Ex.3:**  $A = \begin{bmatrix} -1 & -2 \\ -3 & 2 \\ 1 & 0 \end{bmatrix}_{3 \times 2}$ ,  $B = \begin{bmatrix} 1 & 2 \\ -1 & -2 \end{bmatrix}_{2 \times 2}$  Find AB and BA if they exist.

**Solution:** Here A is order of  $3 \times 2$  and B is order of  $2 \times 2$ . By conformability of product, AB is defined but BA is not defined.

$$\begin{aligned} \therefore AB &= \begin{bmatrix} -1 & -2 \\ -3 & 2 \\ 1 & 0 \end{bmatrix} \begin{bmatrix} 1 & 2 \\ -1 & -2 \end{bmatrix} \\ &= \begin{bmatrix} -1+2 & -2+4 \\ -3-2 & -6-4 \\ 1+0 & 2+0 \end{bmatrix} \\ &= \begin{bmatrix} 1 & 2 \\ -5 & -10 \\ 1 & 2 \end{bmatrix} \end{aligned}$$

**Ex.4:** Let  $A = \begin{bmatrix} 3 & 2 & -1 \\ -2 & 5 & 4 \end{bmatrix}_{2 \times 3}$ ,  $B = \begin{bmatrix} 3 & -3 \\ -4 & 2 \end{bmatrix}_{2 \times 2}$  Find AB and BA whichever exists.

**Solution:** Since number of columns of A  $\neq$  number of rows of B

$\therefore$  Product of AB is not defined. But number of columns of B = number of rows of A=2, the product BA is exists,

$$\therefore BA = \begin{bmatrix} 3 & -3 \\ -4 & 2 \end{bmatrix} \begin{bmatrix} 3 & 2 & -1 \\ -2 & 5 & 4 \end{bmatrix}$$

$$\begin{aligned}
&= \begin{bmatrix} 9+6 & 6-15 & -3-12 \\ -12-4 & -8+10 & 4+8 \end{bmatrix} \\
&= \begin{bmatrix} 15 & -9 & -15 \\ -16 & 2 & 12 \end{bmatrix}
\end{aligned}$$

**Ex.5:** Let  $A = \begin{bmatrix} 4 & -3 \\ 5 & 2 \end{bmatrix}$  and  $B = \begin{bmatrix} -1 & 3 \\ 4 & -2 \end{bmatrix}$ , Find  $AB$  and  $BA$  which ever exist.

**Solution:** Since  $A$  and  $B$  are two matrices of same order  $2 \times 2$ .

$\therefore$  Both the products  $AB$  and  $BA$  exist and both the products are of same order  $2 \times 2$ .

$$\begin{aligned}
AB &= \begin{bmatrix} 4 & -3 \\ 5 & 2 \end{bmatrix} \begin{bmatrix} -1 & 3 \\ 4 & -2 \end{bmatrix} \\
&= \begin{bmatrix} -4-12 & 12+6 \\ -5+8 & 15-4 \end{bmatrix} \\
&= \begin{bmatrix} -16 & 18 \\ 3 & 11 \end{bmatrix}
\end{aligned}$$

$$\begin{aligned}
BA &= \begin{bmatrix} -1 & 3 \\ 4 & -2 \end{bmatrix} \begin{bmatrix} 4 & -3 \\ 5 & 2 \end{bmatrix} \\
&= \begin{bmatrix} -4+15 & 3+6 \\ 16-10 & -12-4 \end{bmatrix} \\
&= \begin{bmatrix} 11 & 9 \\ 6 & -16 \end{bmatrix}
\end{aligned}$$

Here again  $AB \neq BA$

**Remark:** 1) If  $AB$  exists,  $BA$  may or may not exist.

2) If  $BA$  exists,  $AB$  may or may not exist.

3) If  $AB$  and  $BA$  both exist they may or may not be equal.

## 2.4 Properties of Matrix Multiplication:

- 1) For matrices  $A$  and  $B$ , matrix multiplication is not commutative, that is, in general  $AB \neq BA$ .
- 2) For three matrices  $A, B, C$ , matrix multiplication is associative. That is  $(AB)C = A(BC)$  if orders of matrices are suitable for multiplication.

**For example:** Let  $A = \begin{bmatrix} 1 & 2 \\ 4 & 3 \end{bmatrix}$ ,  $B = \begin{bmatrix} 1 & -1 & 2 \\ 0 & -1 & 3 \end{bmatrix}$ ,  $C = \begin{bmatrix} -2 & 1 \\ 3 & -1 \\ 0 & 2 \end{bmatrix}$

$$\text{Then } AB = \begin{bmatrix} 1 & 2 \\ 4 & 3 \end{bmatrix} \begin{bmatrix} 1 & -1 & 2 \\ 0 & -1 & 3 \end{bmatrix}$$

$$\begin{aligned}
&= \begin{bmatrix} 1 & -1-2 & 2+6 \\ 4 & -4-3 & 8+9 \end{bmatrix} \\
&= \begin{bmatrix} 1 & -3 & 8 \\ 4 & -7 & 17 \end{bmatrix} \\
(AB)C &= \begin{bmatrix} 1 & -3 & 8 \\ 4 & -7 & 17 \end{bmatrix} \begin{bmatrix} -2 & 1 \\ 3 & -1 \\ 0 & 2 \end{bmatrix} \\
&= \begin{bmatrix} -2-9 & 1+3+16 \\ -8-21 & 4+7+34 \end{bmatrix} \\
&= \begin{bmatrix} -11 & 20 \\ -29 & 45 \end{bmatrix} \quad \dots (1)
\end{aligned}$$

$$\begin{aligned}
\therefore BC &= \begin{bmatrix} 1 & -1 & 2 \\ 0 & -1 & 3 \end{bmatrix} \begin{bmatrix} -2 & 1 \\ 3 & -1 \\ 0 & 2 \end{bmatrix} \\
&= \begin{bmatrix} -2-3 & 1+1+4 \\ -3 & 1+6 \end{bmatrix} \\
&= \begin{bmatrix} -5 & 6 \\ -3 & 7 \end{bmatrix}
\end{aligned}$$

$$\begin{aligned}
\text{Now, } A(BC) &= \begin{bmatrix} 1 & 2 \\ 4 & 3 \end{bmatrix} \begin{bmatrix} -5 & 6 \\ -3 & 7 \end{bmatrix} \\
&= \begin{bmatrix} -5-6 & 6+14 \\ -20-9 & 24+21 \end{bmatrix} \\
&= \begin{bmatrix} -11 & 20 \\ -29 & 45 \end{bmatrix} \quad \dots (2)
\end{aligned}$$

From (1) and (2),  $(AB)C = A(BC)$

3) For three matrices A, B, C, matrix multiplication is distributive over addition.

- i)  $A(B + C) = AB + AC$  (left distributive law)
- ii)  $(B + C)A = BA + CA$  (right distributive law)

These laws can be verified by examples.

4) For a given square matrix A, there exists a unit matrix I of the same order as that of A, such that  $AI = IA = A$ . I is called Identity matrix for matrix multiplication.

**For example:** Let  $A = \begin{bmatrix} 3 & -2 & -1 \\ 2 & 0 & 4 \\ 1 & 3 & 2 \end{bmatrix}$ ,  $I = \begin{bmatrix} 1 & 0 & 0 \\ 0 & 1 & 0 \\ 0 & 0 & 1 \end{bmatrix}$

$$\begin{aligned}
\text{Then AI} &= \begin{bmatrix} 3 & -2 & -1 \\ 2 & 0 & 4 \\ 1 & 3 & 2 \end{bmatrix} \begin{bmatrix} 1 & 0 & 0 \\ 0 & 1 & 0 \\ 0 & 0 & 1 \end{bmatrix} \\
&= \begin{bmatrix} 3+0+0 & 0-2+0 & 0+0-1 \\ 2+0+0 & 0+0+0 & 0+0+4 \\ 1+0+0 & 0+3+0 & 0+0+2 \end{bmatrix} \\
&= \begin{bmatrix} 3 & -2 & -1 \\ 2 & 0 & 4 \\ 1 & 3 & 2 \end{bmatrix} \\
&= \text{IA}
\end{aligned}$$

- 5) For any matrix A, there exists a null matrix O such that a)  $AO = O$  and b)  $OA = O$ .  
6) The products of two non zero matrices can be a zero matrix. That is  $AB = O$  but  $A \neq O, B \neq O$ .

**For example:** Let  $A = \begin{bmatrix} 1 & 0 \\ 2 & 0 \end{bmatrix}$ ,  $B = \begin{bmatrix} 0 & 0 \\ -1 & 1 \end{bmatrix}$ ,

$$\text{Here } A \neq O, B \neq O \text{ but } AB = \begin{bmatrix} 1 & 0 \\ 2 & 0 \end{bmatrix} \begin{bmatrix} 0 & 0 \\ -1 & 1 \end{bmatrix} = \begin{bmatrix} 0 & 0 \\ 0 & 0 \end{bmatrix}, \text{ that is } AB = O$$

- 7) Positive integer powers of a square matrix A are obtained by repeated multiplication of A by itself. That is  $A^2 = AA, A^3 = AAA, \dots, A^n = AA \dots n \text{ times}$

### SOLVED EXAMPLES

**Ex.1:** If  $A = \begin{bmatrix} 1 & -1 & 2 \\ 0 & -1 & 3 \end{bmatrix}$ ,  $B = \begin{bmatrix} -2 & 1 \\ 3 & -1 \\ 0 & 2 \end{bmatrix}$ , show that the matrix AB is non singular,

$$\begin{aligned}
\text{Solution: let } AB &= \begin{bmatrix} 1 & -1 & 2 \\ 0 & -1 & 3 \end{bmatrix} \begin{bmatrix} -2 & 1 \\ 3 & -1 \\ 0 & 2 \end{bmatrix} \\
&= \begin{bmatrix} -2-3+0 & 1+1+4 \\ 0-3+0 & 0+1+6 \end{bmatrix} \\
&= \begin{bmatrix} -5 & 6 \\ -3 & 7 \end{bmatrix},
\end{aligned}$$

$$\therefore |AB| = \begin{vmatrix} -5 & 6 \\ -3 & 7 \end{vmatrix} = -35 + 18 = -17 \neq 0$$

$\therefore$  By definition, matrix AB is non singular.

**Ex. 2:** If  $A = \begin{bmatrix} 1 & 3 & 3 \\ 3 & 1 & 3 \\ 3 & 3 & 1 \end{bmatrix}$  find  $A^2 - 5A$ . What is your conclusion?

**Solution :** Let  $A^2 = A.A$

$$= \begin{bmatrix} 1 & 3 & 3 \\ 3 & 1 & 3 \\ 3 & 3 & 1 \end{bmatrix} \begin{bmatrix} 1 & 3 & 3 \\ 3 & 1 & 3 \\ 3 & 3 & 1 \end{bmatrix}$$

$$= \begin{bmatrix} 1+9+9 & 3+3+9 & 3+9+3 \\ 3+3+9 & 9+1+9 & 9+3+3 \\ 3+9+3 & 9+3+3 & 9+9+1 \end{bmatrix}$$

$$= \begin{bmatrix} 19 & 15 & 15 \\ 15 & 19 & 15 \\ 15 & 15 & 19 \end{bmatrix}$$

$$\therefore A^2 - 5A = \begin{bmatrix} 19 & 15 & 15 \\ 15 & 19 & 15 \\ 15 & 15 & 19 \end{bmatrix} - 5 \begin{bmatrix} 1 & 3 & 3 \\ 3 & 1 & 3 \\ 3 & 3 & 1 \end{bmatrix}$$

$$= \begin{bmatrix} 19 & 15 & 15 \\ 15 & 19 & 15 \\ 15 & 15 & 19 \end{bmatrix} - \begin{bmatrix} 5 & 15 & 15 \\ 15 & 5 & 15 \\ 15 & 15 & 5 \end{bmatrix}$$

$$\therefore A^2 - 5A = \begin{bmatrix} 14 & 0 & 0 \\ 0 & 14 & 0 \\ 0 & 0 & 14 \end{bmatrix} = 14 \begin{bmatrix} 1 & 0 & 0 \\ 0 & 1 & 0 \\ 0 & 0 & 1 \end{bmatrix} = 14I$$

$\therefore$  By definition of scalar matrix,  $A^2 - 5A$  is a scalar matrix.

**Ex. 3:** If  $A = \begin{bmatrix} 3 & -2 \\ 4 & -2 \end{bmatrix}$ , find  $k$ , so that  $A^2 - kA + 2I = O$ , where  $I$  is a  $2 \times 2$  the identify matrix and  $O$  is null matrix of order 2.

**Solution:** Given  $A^2 - kA + 2I = O$

$\therefore$  Here,  $A^2 = AA$

$$= \begin{bmatrix} 3 & -2 \\ 4 & -2 \end{bmatrix} \begin{bmatrix} 3 & -2 \\ 4 & -2 \end{bmatrix}$$

$$= \begin{bmatrix} 9-8 & -6+4 \\ 12-8 & -8+4 \end{bmatrix}$$

$$= \begin{bmatrix} 1 & -2 \\ 4 & -4 \end{bmatrix}$$

$$\therefore A^2 - kA + 2I = O$$

$$\therefore \begin{bmatrix} 1 & -2 \\ 4 & -4 \end{bmatrix} - k \begin{bmatrix} 3 & -2 \\ 4 & -2 \end{bmatrix} + 2 \begin{bmatrix} 1 & 0 \\ 0 & 1 \end{bmatrix} = O$$

$$\therefore \begin{bmatrix} 1 & -2 \\ 4 & -4 \end{bmatrix} - \begin{bmatrix} 3k & -2k \\ 4k & -2k \end{bmatrix} + \begin{bmatrix} 2 & 0 \\ 0 & 2 \end{bmatrix} = \begin{bmatrix} 0 & 0 \\ 0 & 0 \end{bmatrix}$$

$$\therefore \begin{bmatrix} 1-3k+2 & -2+2k \\ 4-4k & -4+2k+2 \end{bmatrix} = \begin{bmatrix} 0 & 0 \\ 0 & 0 \end{bmatrix}$$

$\therefore$  Using definition of equality of matrices, we have

$$\left. \begin{array}{l} 1-3k+2=0 \\ -2+2k=0 \\ 4-4k=0 \\ -4+2k+2=0 \end{array} \right\} \begin{array}{l} \therefore 3k=3 \\ \therefore 2k=2 \\ \therefore 4k=4 \\ \therefore 2k=2 \end{array} \quad k=1$$

**Ex. 4:** Find  $x$  and  $y$ , if  $\begin{bmatrix} 2 & 0 & 3 \end{bmatrix} \left\{ 3 \begin{bmatrix} 6 & 3 \\ -1 & 2 \\ 5 & 4 \end{bmatrix} + 2 \begin{bmatrix} -4 & -1 \\ 1 & 0 \\ -3 & -4 \end{bmatrix} \right\} = \begin{bmatrix} x & y \end{bmatrix}$

**Solution:** Given  $\begin{bmatrix} 2 & 0 & 3 \end{bmatrix} \left\{ 3 \begin{bmatrix} 6 & 3 \\ -1 & 2 \\ 5 & 4 \end{bmatrix} + 2 \begin{bmatrix} -4 & -1 \\ 1 & 0 \\ -3 & -4 \end{bmatrix} \right\} = \begin{bmatrix} x & y \end{bmatrix}$

$$\therefore \begin{bmatrix} 2 & 0 & 3 \end{bmatrix} \left\{ \begin{bmatrix} 18 & 9 \\ -3 & 6 \\ 15 & 12 \end{bmatrix} + \begin{bmatrix} -8 & -2 \\ 2 & 0 \\ -6 & -8 \end{bmatrix} \right\} = \begin{bmatrix} x & y \end{bmatrix}$$

$$\therefore \begin{bmatrix} 2 & 0 & 3 \end{bmatrix} \begin{bmatrix} 10 & 7 \\ -1 & 6 \\ 9 & 4 \end{bmatrix} = \begin{bmatrix} x & y \end{bmatrix}$$

$$\therefore \begin{bmatrix} 20+27 & 14+12 \end{bmatrix} = \begin{bmatrix} x & y \end{bmatrix}$$

$$\therefore \begin{bmatrix} 47 & 26 \end{bmatrix} = \begin{bmatrix} x & y \end{bmatrix}$$

$\therefore x = 47, y = 26$  by definition of equality of matrices.

$$(A + B)(A - B) = A^2 - AB + BA - B^2$$

### Let's Note :

Using the distributive laws discussed earlier, we can derive the following results. If  $A$  and  $B$  are square matrices of the same order, then

i)  $(A + B)^2 = A^2 + AB + BA + B^2$

ii)  $(A - B)^2 = A^2 - AB - BA + B^2$



**Ex 5:** A School purchased 8 dozen Mathematics books, 7 dozen physics books and 10 dozen chemistry books of standard XI. The price of one book of Mathematics, Physics and Chemistry are Rs.50, Rs.40 and Rs.60 respectively. Use matrix multiplication to find the total amount that the school pays the book seller.

**Solution:** Let A be the column matrix of books of different subjects and let B be the row matrix of prices of one book of each subject.

$$A = \begin{bmatrix} 8 \times 12 \\ 7 \times 12 \\ 10 \times 12 \end{bmatrix} = \begin{bmatrix} 96 \\ 84 \\ 120 \end{bmatrix} \quad B = [50 \quad 40 \quad 60]$$

$\therefore$  The total amount received by the bookseller is obtained by the matrix BA.

$$\begin{aligned} \therefore BA &= [50 \quad 40 \quad 60] \begin{bmatrix} 96 \\ 84 \\ 120 \end{bmatrix} \\ &= [50 \times 96 + 40 \times 84 + 60 \times 120] \\ &= [4800 + 3360 + 7200] \\ &= [15360] \end{aligned}$$

Thus the amount received by the bookseller from the school is Rs. 15360.

### EXERCISE 2.3

- 1) Evaluate i)  $\begin{bmatrix} 3 \\ 2 \\ 1 \end{bmatrix} [2 \quad -4 \quad 3]$  ii)  $[2 \quad -1 \quad 3] \begin{bmatrix} 4 \\ 3 \\ 1 \end{bmatrix}$
- 2) If  $A = \begin{bmatrix} -1 & 1 & 1 \\ 2 & 3 & 0 \\ 1 & -3 & 1 \end{bmatrix}$ ,  $B = \begin{bmatrix} 2 & 1 & 4 \\ 3 & 0 & 2 \\ 1 & 2 & 1 \end{bmatrix}$ . State whether  $AB = BA$ ? Justify your answer.
- 3) Show that  $AB = BA$  where,  $A = \begin{bmatrix} -2 & 3 & -1 \\ -1 & 2 & -1 \\ -6 & 9 & -4 \end{bmatrix}$ ,  $B = \begin{bmatrix} 1 & 3 & -1 \\ 2 & 2 & -1 \\ 3 & 0 & -1 \end{bmatrix}$
- 4) Verify  $A(BC) = (AB)C$ , if  $A = \begin{bmatrix} 1 & 0 & 1 \\ 2 & 3 & 0 \\ 0 & 4 & 5 \end{bmatrix}$ ,  $B = \begin{bmatrix} 2 & -2 \\ -1 & 1 \\ 0 & 3 \end{bmatrix}$  and  $C = \begin{bmatrix} 3 & 2 & -1 \\ 2 & 0 & -2 \end{bmatrix}$
- 5) Verify that  $A(B+C) = AB + AC$ , if  $A = \begin{bmatrix} 4 & -2 \\ 2 & 3 \end{bmatrix}$ ,  $B = \begin{bmatrix} -1 & 1 \\ 3 & -2 \end{bmatrix}$  and  $C = \begin{bmatrix} 4 & 1 \\ 2 & -1 \end{bmatrix}$

- 6) If  $A = \begin{bmatrix} 4 & 3 & 2 \\ -1 & 2 & 0 \end{bmatrix}$ ,  $B = \begin{bmatrix} 1 & 2 \\ -1 & 0 \\ 1 & -2 \end{bmatrix}$  show that matrix  $AB$  is non singular.
- 7) If  $A + I = \begin{bmatrix} 1 & 2 & 0 \\ 5 & 4 & 2 \\ 0 & 7 & -3 \end{bmatrix}$ , find the product  $(A + I)(A - I)$ .
- 8) If  $A = \begin{bmatrix} 1 & 2 & 2 \\ 2 & 1 & 2 \\ 2 & 2 & 1 \end{bmatrix}$ , show that  $A^2 - 4A$  is a scalar matrix.
- 9) If  $A = \begin{bmatrix} 1 & 0 \\ -1 & 7 \end{bmatrix}$ , find  $k$  so that  $A^2 - 8A - kI = O$ , where  $I$  is a  $2 \times 2$  unit and  $O$  is null matrix of order 2.
- 10) If  $A = \begin{bmatrix} 3 & 1 \\ -1 & 2 \end{bmatrix}$ , prove that  $A^2 - 5A + 7I = 0$ , where  $I$  is  $2 \times 2$  unit matrix.
- 11) If  $A = \begin{bmatrix} 1 & 2 \\ -1 & -2 \end{bmatrix}$ ,  $B = \begin{bmatrix} 2 & a \\ -1 & b \end{bmatrix}$  and if  $(A + B)^2 = A^2 + B^2$ , find value of  $a$  and  $b$ .
- 12) Find  $k$ , If  $A = \begin{bmatrix} 3 & -2 \\ 4 & -2 \end{bmatrix}$  and  $A^2 = kA - 2I$ .
- 13) Find  $x$  and  $y$ , If  $\left\{ 4 \begin{bmatrix} 2 & -1 & 3 \\ 1 & 0 & 2 \end{bmatrix} - \begin{bmatrix} 3 & -3 & 4 \\ 2 & 1 & 1 \end{bmatrix} \right\} \begin{bmatrix} 2 \\ -1 \\ 1 \end{bmatrix} = \begin{bmatrix} x \\ y \end{bmatrix}$
- 14) Find  $x, y, z$  if  $\left\{ 3 \begin{bmatrix} 2 & 0 \\ 0 & 2 \\ 2 & 2 \end{bmatrix} - 4 \begin{bmatrix} 1 & 1 \\ -1 & 2 \\ 3 & 1 \end{bmatrix} \right\} \begin{bmatrix} 1 \\ 2 \end{bmatrix} = \begin{bmatrix} x-3 \\ y-1 \\ 2z \end{bmatrix}$
- 15) Jay and Ram are two friends. Jay wants to buy 4 pens and 8 notebooks, Ram wants to buy 5 pens and 12 notebooks. The price of One pen and one notebook was Rs. 6 and Rs.10 respectively. Using matrix multiplication, find the amount each one of them requires for buying the pens and notebooks.

• **Properties of the transpose of a matrix:**

- (i) If  $A$  and  $B$  are two matrices of same order, then  $(A + B)^T = A^T + B^T$
- (ii) If  $A$  is a matrix and  $k$  is a constant, then  $(kA)^T = kA^T$
- (iii) If  $A$  and  $B$  are conformable for the product  $AB$ , then  $(AB)^T = B^T A^T$

**For example:** Let  $A = \begin{bmatrix} 1 & 2 & 1 \\ 3 & 1 & 3 \end{bmatrix}$ ,  $B = \begin{bmatrix} 2 & 3 \\ 1 & 2 \\ 1 & 2 \end{bmatrix}$ ,  $\therefore AB$  is defined and

$$AB = \begin{bmatrix} 2+2+1 & 3+4+2 \\ 6+1+3 & 9+2+6 \end{bmatrix} = \begin{bmatrix} 5 & 9 \\ 10 & 17 \end{bmatrix} \quad \therefore (AB)^T = \begin{bmatrix} 5 & 10 \\ 9 & 17 \end{bmatrix} \dots\dots\dots (1)$$

$$\text{Now } A^T = \begin{bmatrix} 1 & 3 \\ 2 & 1 \\ 1 & 3 \end{bmatrix}, B^T = \begin{bmatrix} 2 & 1 & 1 \\ 3 & 2 & 2 \end{bmatrix}, \quad \therefore B^T A^T = \begin{bmatrix} 2 & 1 & 1 \\ 3 & 2 & 2 \end{bmatrix} \begin{bmatrix} 1 & 3 \\ 2 & 1 \\ 1 & 3 \end{bmatrix}$$

$$\therefore B^T A^T = \begin{bmatrix} 2+2+1 & 6+1+3 \\ 3+4+2 & 9+2+6 \end{bmatrix} = \begin{bmatrix} 5 & 10 \\ 9 & 17 \end{bmatrix} \dots\dots\dots (2)$$

$\therefore$  From (1) and (2) we have proved that,  $(AB)^T = B^T A^T$

In general  $(A_1 A_2 A_3 \dots\dots\dots A_n)^T = A_n^T \dots\dots\dots A_3^T A_2^T A_1^T$

(iv) If  $A$  is a symmetric matrix, then  $A^T = A$ .

**For example:** Let  $A = \begin{bmatrix} 2 & -3 & 4 \\ -3 & 5 & -2 \\ 4 & -2 & 1 \end{bmatrix}$  be a symmetric matrix.

$$A^T = \begin{bmatrix} 2 & -3 & 4 \\ -3 & 5 & -2 \\ 4 & -2 & 1 \end{bmatrix} = A$$

(v) If  $A$  is a skew symmetric matrix, then  $A^T = -A$ .

**For example:** Let  $A = \begin{bmatrix} 0 & 5 & 4 \\ -5 & 0 & -2 \\ -4 & 2 & 0 \end{bmatrix}$  be a skew symmetric matrix.

$$\therefore A^T = \begin{bmatrix} 0 & -5 & -4 \\ 5 & 0 & 2 \\ 4 & -2 & 0 \end{bmatrix} = - \begin{bmatrix} 0 & 5 & 4 \\ -5 & 0 & -2 \\ -4 & 2 & 0 \end{bmatrix} = -A, \quad \therefore A^T = -A.$$

(vi) If  $A$  is a square matrix, then (a)  $A + A^T$  is symmetric.

(b)  $A - A^T$  is skew symmetric.

**For example:** (a) Let  $A = \begin{bmatrix} 3 & 5 & 7 \\ 2 & 4 & -6 \\ 3 & 8 & -5 \end{bmatrix}$ ,  $\therefore A^T = \begin{bmatrix} 3 & 2 & 3 \\ 5 & 4 & 8 \\ 7 & -6 & -5 \end{bmatrix}$

$$\text{Now } A + A^T = \begin{bmatrix} 3 & 5 & 7 \\ 2 & 4 & -6 \\ 3 & 8 & -5 \end{bmatrix} + \begin{bmatrix} 3 & 2 & 3 \\ 5 & 4 & 8 \\ 7 & -6 & -5 \end{bmatrix} = \begin{bmatrix} 6 & 7 & 10 \\ 7 & 8 & 2 \\ 10 & 2 & -10 \end{bmatrix}$$

$\therefore A + A^T$  is a symmetric matrix, by definition.

$$(b) \quad \text{Let } A - A^T = \begin{bmatrix} 3 & 5 & 7 \\ 2 & 4 & -6 \\ 3 & 8 & -5 \end{bmatrix} - \begin{bmatrix} 3 & 2 & 3 \\ 5 & 4 & 8 \\ 7 & -6 & -5 \end{bmatrix} = \begin{bmatrix} 0 & 3 & 4 \\ -3 & 0 & -14 \\ -4 & 14 & 0 \end{bmatrix}$$

$\therefore A - A^T$  is a skew symmetric matrix, by definition.

**Let's Note:** A square matrix  $A$  can be expressed as the sum of a symmetric and a skew symmetric matrix as follows.

$$A = \frac{1}{2} (A + A^T) + \frac{1}{2} (A - A^T)$$

**For example:** Let  $A = \begin{bmatrix} 4 & -5 & 3 \\ -6 & 2 & 1 \\ 7 & 8 & -9 \end{bmatrix}$ ,  $\therefore A^T = \begin{bmatrix} 4 & -6 & 7 \\ -5 & 2 & 8 \\ 3 & 1 & -9 \end{bmatrix}$

$$A + A^T = \begin{bmatrix} 4 & -5 & 3 \\ -6 & 2 & 1 \\ 7 & 8 & -9 \end{bmatrix} + \begin{bmatrix} 4 & -6 & 7 \\ -5 & 2 & 8 \\ 3 & 1 & -9 \end{bmatrix} = \begin{bmatrix} 8 & -11 & 10 \\ -11 & 4 & 9 \\ 10 & 9 & -18 \end{bmatrix}$$

$$\text{Let } P = \frac{1}{2} (A + A^T) = \frac{1}{2} \begin{bmatrix} 8 & -11 & 10 \\ -11 & 4 & 9 \\ 10 & 9 & -18 \end{bmatrix} = \begin{bmatrix} 4 & -\frac{11}{2} & 5 \\ -\frac{11}{2} & 2 & \frac{9}{2} \\ 5 & \frac{9}{2} & -18 \end{bmatrix}$$

The matrix  $P$  is a symmetric matrix.

$$\text{Also } A - A^T = \begin{bmatrix} 4 & -5 & 3 \\ -6 & 2 & 1 \\ 7 & 8 & -9 \end{bmatrix} - \begin{bmatrix} 4 & -6 & 7 \\ -5 & 2 & 8 \\ 3 & 1 & -9 \end{bmatrix} = \begin{bmatrix} 0 & 1 & -4 \\ -1 & 0 & -7 \\ 4 & 7 & 0 \end{bmatrix}$$

$$\text{Let } Q = \frac{1}{2} (A - A^T) = \frac{1}{2} \begin{bmatrix} 0 & 1 & -4 \\ -1 & 0 & -7 \\ 4 & 7 & 0 \end{bmatrix} = \begin{bmatrix} 0 & \frac{1}{2} & -2 \\ -\frac{1}{2} & 0 & -\frac{7}{2} \\ 2 & \frac{7}{2} & 0 \end{bmatrix}$$

The matrix  $Q$  is a skew symmetric matrix.

Since  $P + Q =$  symmetric matrix + skew symmetric matrix.

Thus  $A = P + Q$ .

### EXERCISE 2.4

- (1) Find  $A^T$ , if (i)  $A = \begin{bmatrix} 1 & 3 \\ -4 & 5 \end{bmatrix}$       (ii)  $A = \begin{bmatrix} 2 & -6 & 1 \\ -4 & 0 & 5 \end{bmatrix}$
- (2) If  $A = [a_{ij}]_{3 \times 3}$  where  $a_{ij} = 2(i - j)$ . Find  $A$  and  $A^T$ . State whether  $A$  and  $A^T$  both are symmetric or skew symmetric matrices ?
- (3) If  $A = \begin{bmatrix} 5 & -3 \\ 4 & -3 \\ -2 & 1 \end{bmatrix}$ , Prove that  $(A^T)^T = A$ .
- (4) If  $A = \begin{bmatrix} 1 & 2 & -5 \\ 2 & -3 & 4 \\ -5 & 4 & 9 \end{bmatrix}$ , Prove that  $A^T = A$ .
- (5) If  $A = \begin{bmatrix} 2 & -3 \\ 5 & -4 \\ -6 & 1 \end{bmatrix}$ ,  $B = \begin{bmatrix} 2 & 1 \\ 4 & -1 \\ -3 & 3 \end{bmatrix}$ ,  $C = \begin{bmatrix} 1 & 2 \\ -1 & 4 \\ -2 & 3 \end{bmatrix}$  then show that
- (i)  $(A + B)^T = A^T + B^T$       (ii)  $(A - C)^T = A^T - C^T$
- (6) If  $A = \begin{bmatrix} 5 & 4 \\ -2 & 3 \end{bmatrix}$  and  $B = \begin{bmatrix} -1 & 3 \\ 4 & -1 \end{bmatrix}$ , then find  $C^T$ , such that  $3A - 2B + C = I$ , where  $I$  is the unit matrix of order 2.
- (7) If  $A = \begin{bmatrix} 7 & 3 & 0 \\ 0 & 4 & -2 \end{bmatrix}$ ,  $B = \begin{bmatrix} 0 & -2 & 3 \\ 2 & 1 & -4 \end{bmatrix}$  then find
- (i)  $A^T + 4B^T$       (ii)  $5A^T - 5B^T$
- (8) If  $A = \begin{bmatrix} 1 & 0 & 1 \\ 3 & 1 & 2 \end{bmatrix}$ ,  $B = \begin{bmatrix} 2 & 1 & -4 \\ 3 & 5 & -2 \end{bmatrix}$  and  $C = \begin{bmatrix} 0 & 2 & 3 \\ -1 & -1 & 0 \end{bmatrix}$ , verify that
- $(A + 2B + 3C)^T = A^T + 2B^T + 3C^T$
- (9) If  $A = \begin{bmatrix} -1 & 2 & 1 \\ -3 & 2 & -3 \end{bmatrix}$  and  $B = \begin{bmatrix} 2 & 1 \\ -3 & 2 \\ -1 & 3 \end{bmatrix}$ , prove that  $(A + B^T)^T = A^T + B$ .
- (10) Prove that  $A + A^T$  is a symmetric and  $A - A^T$  is a skew symmetric matrix, where
- (i)  $A = \begin{bmatrix} 1 & 2 & 4 \\ 3 & 2 & 1 \\ -2 & -3 & 2 \end{bmatrix}$       (ii)  $A = \begin{bmatrix} 5 & 2 & -4 \\ 3 & -7 & 2 \\ 4 & -5 & -3 \end{bmatrix}$
- (11) Express each of the following matrix as the sum of a symmetric and a skew symmetric matrix.
- (i)  $\begin{bmatrix} 4 & -2 \\ 3 & -5 \end{bmatrix}$       (ii)  $\begin{bmatrix} 3 & 3 & -1 \\ -2 & -2 & 1 \\ -4 & -5 & 2 \end{bmatrix}$

(12) If  $A = \begin{bmatrix} 2 & -1 \\ 3 & -2 \\ 4 & 1 \end{bmatrix}$  and  $B = \begin{bmatrix} 0 & 3 & -4 \\ 2 & -1 & 1 \end{bmatrix}$ , verify that

(i)  $(AB)^T = B^T A^T$                       (ii)  $(BA)^T = A^T B^T$

## 2.5 Elementary Transformations:

Let us understand the meaning and application of elementary transformations. There are three elementary transformations of a matrix. They can be used on rows and columns.

**a) Interchange of any two rows or any two columns:** If we interchange the  $i^{\text{th}}$  row and the  $j^{\text{th}}$  row of a matrix then, after this interchange, the original matrix is transformed to a new matrix.

This transformation is symbolically denoted as  $R_i \leftrightarrow R_j$  or  $R_{ij}$

The same transformation can be applied to two columns, say  $C_i \leftrightarrow C_j$  or  $C_{ij}$

### For Example:

If  $A = \begin{bmatrix} 5 & 7 \\ 3 & 2 \end{bmatrix}$  then  $R_1 \leftrightarrow R_2$  gives new matrix  $\begin{bmatrix} 3 & 2 \\ 5 & 7 \end{bmatrix}$

and  $C_1 \leftrightarrow C_2$  gives new matrix  $\begin{bmatrix} 7 & 5 \\ 2 & 3 \end{bmatrix}$

**b) Multiplication of the elements of any row or column by a non zero scalar:** If  $k$  is a non zero scalar and the row  $R_i$  is to be multiplied by a Scalar  $k$ , then we multiply every element of  $R_i$  by the Scalar  $k$ . Symbolically the transformation is denoted by  $kR_i$  or  $R_i(k)$

**For example:** If  $A = \begin{bmatrix} 1 & 2 & 3 \\ 2 & 5 & 0 \\ 4 & 1 & 3 \end{bmatrix}$  then  $4R_2$  gives  $\begin{bmatrix} 1 & 2 & 3 \\ 8 & 20 & 0 \\ 4 & 1 & 3 \end{bmatrix}$

Similarly, if any column of the matrix is multiplied by a constant then we multiply every element of the column by the constant. It is denoted by  $kC_i$  or  $C_i(k)$

If  $B = \begin{bmatrix} 2 & 3 \\ -5 & 1 \end{bmatrix}$  then  ${}^3C_2$  gives  $\begin{bmatrix} 2 & 9 \\ -5 & 3 \end{bmatrix}$

**c) Adding the scalar multiples of all the elements of any row (column) to corresponding elements of any other row (column):** If  $k$  is a non-zero scalar and the  $k$ -multiples of the elements of  $R_j(C_j)$  are to be added to the elements of  $R_i(C_i)$  then the transformation is symbolically denoted as  $R_i + kR_j$  or  $C_i + kC_j$

### For example:

1) If  $A = \begin{bmatrix} 2 & 5 \\ 7 & 8 \end{bmatrix}$  then  $R_2 + 2R_1$  gives  $= \begin{bmatrix} 2 & 5 \\ 7+2(2) & 8+2(5) \end{bmatrix}$   
 $= \begin{bmatrix} 2 & 5 \\ 11 & 18 \end{bmatrix}$

$$2) \text{ If } B = \begin{bmatrix} 3 & -2 \\ 1 & 4 \end{bmatrix} \text{ then } C_1 - 2C_2 = \begin{bmatrix} 3 - 2(-2) & -2 \\ 1 - 2(4) & 4 \end{bmatrix} \\ = \begin{bmatrix} 7 & -2 \\ -7 & 4 \end{bmatrix}$$

**Let's Note:**

- 1) After transformation  $R_i + kR_j$ ,  $R_j$  remains same as in the original matrix. Similarly with the transformation  $C_i + kC_j$ ,  $C_j$  remains same as in the original matrix.
- 2) The elements of a row or multiples of the element of a row can not be added to the elements of a column or conversely.
- 3) When any elementary row transformations are applied on both the sides of  $AB = C$ , the prefactor A changes and B remains unchanged. The same row transformations are applied on C.

**For Example:**

$$\text{If } A = \begin{bmatrix} 1 & 2 \\ 3 & 4 \end{bmatrix}, B = \begin{bmatrix} -1 & 0 \\ 1 & 5 \end{bmatrix} \text{ then } AB = \begin{bmatrix} 1 & 10 \\ 1 & 20 \end{bmatrix} = C \text{ say}$$

Now if we require C to be transformed to a new matrix by  $R_1 \leftrightarrow R_2$

$$C \rightarrow \begin{bmatrix} 1 & 20 \\ 1 & 10 \end{bmatrix}$$

If the same transformation used for A then  $A \rightarrow \begin{bmatrix} 3 & 4 \\ 1 & 2 \end{bmatrix}$  and B remains unchanged then product

$$AB = \begin{bmatrix} 3 & 4 \\ 1 & 2 \end{bmatrix} \begin{bmatrix} -1 & 0 \\ 1 & 5 \end{bmatrix} \\ = \begin{bmatrix} -3+4 & 0+20 \\ -1+2 & 0+10 \end{bmatrix} \\ = \begin{bmatrix} 1 & 20 \\ 1 & 10 \end{bmatrix} \\ = C$$

**SOLVED EXAMPLES**

- 1) If  $A = \begin{bmatrix} 2 & 4 \\ 1 & 7 \end{bmatrix}$  then apply the transformation  $R_1 \leftrightarrow R_2$  on A.

**Solution:** As  $A = \begin{bmatrix} 2 & 4 \\ 1 & 7 \end{bmatrix}$   $R_1 \leftrightarrow R_2$  gives  $R_{12} = \begin{bmatrix} 1 & 7 \\ 2 & 4 \end{bmatrix}$

- 2) If  $B = \begin{bmatrix} 1 & 2 & 3 \\ 4 & 7 & 1 \\ 3 & 2 & 1 \end{bmatrix}$  then apply the transformation  $C_2 - 2C_1$ .

**Solution:** As  $B = \begin{bmatrix} 1 & 2 & 3 \\ 4 & 7 & 1 \\ 3 & 2 & 1 \end{bmatrix}$   $C_2 - 2C_1 = \begin{bmatrix} 1 & 2-2(1) & 3 \\ 4 & 7-2(4) & 1 \\ 3 & 2-2(3) & 1 \end{bmatrix}$

$$= \begin{bmatrix} 1 & 2-2 & 3 \\ 4 & 7-8 & 1 \\ 3 & 2-6 & 1 \end{bmatrix}$$

$$= \begin{bmatrix} 1 & 0 & 3 \\ 4 & -1 & 1 \\ 3 & -4 & 1 \end{bmatrix}$$

3) If  $A = \begin{bmatrix} 1 & -2 & -7 \\ -2 & 1 & 5 \\ 3 & 2 & 1 \end{bmatrix}$  then apply the transformation  $R_2 + 2R_1$ .

**Solution:** As  $A = \begin{bmatrix} 1 & -2 & -7 \\ -2 & 1 & 5 \\ 3 & 2 & 1 \end{bmatrix}$   $R_2 + 2R_1$ ,

$$= \begin{bmatrix} 1 & -2 & -7 \\ -2+2(1) & 1+2(-2) & 5+2(-7) \\ 3 & 2 & 1 \end{bmatrix}$$

$$= \begin{bmatrix} 1 & -2 & -7 \\ -2+2 & 1-4 & 5-14 \\ 3 & 2 & 1 \end{bmatrix}$$

$$= \begin{bmatrix} 1 & -2 & -7 \\ 0 & -3 & -9 \\ 3 & 2 & 1 \end{bmatrix}$$

4) Convert  $\begin{bmatrix} 2 & 3 \\ 1 & 6 \end{bmatrix}$  into identity matrix by suitable row transformations.

**Solution:** Given  $A = \begin{bmatrix} 2 & 3 \\ 1 & 6 \end{bmatrix}$   $R_1 \leftrightarrow R_2$

$$= \begin{bmatrix} 1 & 6 \\ 2 & 3 \end{bmatrix} \quad \text{By } R_2 - 2R_1 \quad \begin{bmatrix} 1 & 6 \\ 0 & -9 \end{bmatrix}$$

$$\frac{-1}{9} R_2, A = \begin{bmatrix} 1 & 6 \\ 0 & 1 \end{bmatrix}$$

$$\text{By } R_1 - 6R_2 = \begin{bmatrix} 1 & 0 \\ 0 & 1 \end{bmatrix} = I$$



## 2.6 Inverse of a matrix :

If  $A$  is a square matrix of order  $m$  and if there exists another square matrix  $B$  of the same order such that  $AB = BA = I$ , where  $I$  is the unit matrix of order  $m$  then  $B$  is called the inverse of  $A$  and is denoted by  $A^{-1}$  (read as  $A$  inverse)

Using the notation  $A^{-1}$  for  $B$  we write the above equations as  $AA^{-1} = A^{-1}A = I$

**Let's Note:** For the existence of inverse of matrix  $A$ , it is necessary that  $|A| \neq 0$ , that is  $A$  is a non singular matrix.

- **Uniqueness of the inverse of a matrix:**

It can be proved that if  $A$  is a square matrix where  $|A| \neq 0$ , then its inverse, say  $A^{-1}$ , is unique.

**Theorem:** Prove that, if  $A$  is a square matrix and its inverse exists then the inverse is unique.

**Proof:** Let  $A$  be a square matrix of order  $m$  and let its inverse exist.

Let, if possible,  $B$  and  $C$  be two inverses of  $A$

Then, by definition of the inverse matrix,

$$AB = BA = I \text{ and } AC = CA = I$$

Now consider  $B = BI$

$$= B(AC)$$

$$= (BA)C$$

$$= IC$$

$$B = C$$

Hence  $B = C$ , that is, the inverse of a matrix is unique.

Inverse of a matrix (if it exists) can be obtained by any of the two methods:

(1) Elementary Transformations                      (2) Adjoint Method.

### 1) Inverse of a non singular matrix by elementary transformations:

By the definition of inverse of a matrix  $A$ , if  $A^{-1}$  exists, then  $AA^{-1} = A^{-1}A = I$ .

To find  $A^{-1}$ , we first convert  $A$  into  $I$ . This can be done by using elementary transformations.

Hence the equation  $AA^{-1} = I$  can be transformed into an equation of the type  $A^{-1} = B$ , by applying the same series of row transformations on both sides of the above equation. Similarly, if we start with the equation  $A^{-1}A = I$  then the transformations should be applied to the columns of  $A$ . Apply column transformations to post factor and the other side, whereas prefactor remains unchanged.

$AA^{-1} = I$  (Row transformation)

$A^{-1}A = I$  (column transformation)

Now if  $A = \begin{bmatrix} a_{11} & a_{12} & a_{13} \\ a_{21} & a_{22} & a_{23} \\ a_{31} & a_{32} & a_{33} \end{bmatrix}$  is a non singular matrix then reduce  $A$  into  $I$

$$\begin{bmatrix} 1 & 0 & 0 \\ 0 & 1 & 0 \\ 0 & 0 & 1 \end{bmatrix}$$

The suitable row transformation are as follows

- 1) Reduce  $a_{11}$  to 1
- 2) Then reduce  $a_{21}$  and  $a_{31}$  to 0
- 3) Reduce  $a_{22}$  to 1
- 4) Then reduce  $a_{12}$  and  $a_{32}$  to 0
- 5) Reduce  $a_{33}$  to 1
- 6) Then reduce  $a_{13}$  and  $a_{23}$  to 0

Remember that the similar working rule (but not the same) can be used if you are using column transformations

$$\begin{array}{ll} a_{11} \rightarrow 1 & a_{12} \text{ and } a_{13} \rightarrow 0 \\ a_{22} \rightarrow 1 & a_{21} \text{ and } a_{23} \rightarrow 0 \\ a_{33} \rightarrow 1 & a_{31} \text{ and } a_{32} \rightarrow 0 \end{array}$$

### SOLVED EXAMPLES

- 1) Find which of the following matrix is invertible

$$\text{(i)} \begin{bmatrix} 1 & 2 \\ 5 & 7 \end{bmatrix} \qquad \text{(ii)} \begin{bmatrix} 2 & 4 \\ 3 & 6 \end{bmatrix} \qquad \text{(iii)} \begin{bmatrix} 1 & 2 & 3 \\ 2 & 4 & 5 \\ 2 & 4 & 6 \end{bmatrix}$$

**Solution:** i)  $A = \begin{bmatrix} 1 & 2 \\ 5 & 7 \end{bmatrix}$

$$\begin{aligned} |A| &= \begin{vmatrix} 1 & 2 \\ 5 & 7 \end{vmatrix} \\ &= 7 - 10 \\ &= -3 \neq 0 \end{aligned}$$

$\therefore A^{-1}$  exists.  $\therefore A$  is invertible matrix.

ii)  $B = \begin{bmatrix} 2 & 4 \\ 3 & 6 \end{bmatrix}$

$$\begin{aligned} |B| &= \begin{vmatrix} 2 & 4 \\ 3 & 6 \end{vmatrix} \\ &= 12 - 12 = 0 \end{aligned}$$

$\therefore B$  is singular matrix and hence  $B^{-1}$  does not exist.

$\therefore B$  is not invertible matrix.

$$\text{iii) } A = \begin{bmatrix} 1 & 2 & 3 \\ 2 & 4 & 5 \\ 2 & 4 & 6 \end{bmatrix}$$

$$|A| = \begin{vmatrix} 1 & 2 & 3 \\ 2 & 4 & 5 \\ 2 & 4 & 6 \end{vmatrix}$$

$$|A| = 2 \begin{vmatrix} 1 & 2 & 3 \\ 2 & 4 & 5 \\ 1 & 2 & 3 \end{vmatrix} \quad (\text{By property of determinant})$$

$$|A| = 2(0) \quad (\text{Row } R_1 \text{ and } R_3 \text{ are identical})$$

$\therefore$  A is singular matrix and hence  $A^{-1}$  does not exist.

$\therefore$  A is not invertible matrix.

2) Find the inverse of  $A = \begin{bmatrix} 2 & 5 \\ 1 & 3 \end{bmatrix}$  by elementary transformation.

**Solution:**  $A = \begin{bmatrix} 2 & 5 \\ 1 & 3 \end{bmatrix}$

$$|A| = \begin{vmatrix} 2 & 5 \\ 1 & 3 \end{vmatrix}$$

$$= 6 - 5 = 1 \neq 0$$

$\therefore A^{-1}$  is exist.

(I)  $AA^{-1} = I$  By Row transformation

$$\begin{bmatrix} 2 & 5 \\ 1 & 3 \end{bmatrix} A^{-1} = \begin{bmatrix} 1 & 0 \\ 0 & 1 \end{bmatrix}$$

Using  $R_1 \leftrightarrow R_2$

$$\begin{bmatrix} 1 & 3 \\ 2 & 5 \end{bmatrix} A^{-1} = \begin{bmatrix} 0 & 1 \\ 1 & 0 \end{bmatrix}$$

Using  $R_2 \rightarrow R_2 - 2R_1$

$$\begin{bmatrix} 1 & 3 \\ 0 & -1 \end{bmatrix} A^{-1} = \begin{bmatrix} 0 & 1 \\ 1 & -2 \end{bmatrix}$$

Using  $R_1 \rightarrow R_1 + 3R_2$

$$\begin{bmatrix} 1 & 0 \\ 0 & -1 \end{bmatrix} A^{-1} = \begin{bmatrix} 3 & -5 \\ 1 & -2 \end{bmatrix}$$

$$\begin{aligned} \therefore R_2 &\rightarrow (-1)R_2 \\ \begin{bmatrix} 0 & 1 \\ 1 & 0 \end{bmatrix} A^{-1} &= \begin{bmatrix} 3 & -5 \\ -1 & 2 \end{bmatrix} \\ IA^{-1} &= \begin{bmatrix} 3 & -5 \\ -1 & 2 \end{bmatrix} \\ \therefore A^{-1} &= \begin{bmatrix} 3 & -5 \\ -1 & 2 \end{bmatrix} \quad \dots\dots\dots (I) \end{aligned}$$

(II)  $A^{-1}A = I$  By column transformations we get,

$${}^{-1}A \begin{bmatrix} 2 & 5 \\ 1 & 3 \end{bmatrix} = \begin{bmatrix} 1 & 0 \\ 0 & 1 \end{bmatrix}$$

$$C_1 \rightarrow \left(\frac{1}{2}\right) C_1$$

$${}^{-1}A \begin{bmatrix} 1 & 5 \\ \frac{1}{2} & 3 \end{bmatrix} = \begin{bmatrix} \frac{1}{2} & 0 \\ 0 & 1 \end{bmatrix}$$

Using  $C_2 \rightarrow C_2 - 5C_1$

$${}^{-1}A \begin{bmatrix} 1 & 0 \\ \frac{1}{2} & \frac{1}{2} \end{bmatrix} = \begin{bmatrix} \frac{1}{2} & \frac{-5}{2} \\ 0 & 1 \end{bmatrix}$$

Using  $C_2 \rightarrow 2C_2$

$${}^{-1}A \begin{bmatrix} 1 & 0 \\ \frac{1}{2} & 1 \end{bmatrix} = \begin{bmatrix} \frac{1}{2} & -5 \\ 0 & 2 \end{bmatrix}$$

Using  $C_1 \rightarrow C_1 - \left(\frac{1}{2}\right) C_2$

$$A^{-1} \begin{bmatrix} 1 & 0 \\ 0 & 1 \end{bmatrix} = \begin{bmatrix} 3 & -5 \\ -1 & 2 \end{bmatrix}$$

$$A^{-1}I = \begin{bmatrix} 3 & -5 \\ -1 & 2 \end{bmatrix}$$

$$A^{-1} = \begin{bmatrix} 3 & -5 \\ -1 & 2 \end{bmatrix} \quad \dots\dots\dots (II)$$

From I and II

$A^{-1}$  is unique.

3) Find the inverse of  $A = \begin{bmatrix} 2 & 0 & -1 \\ 5 & 1 & 0 \\ 0 & 1 & 3 \end{bmatrix}$  by using elementary row transformation.

**Solution:** Let  $A = \begin{bmatrix} 2 & 0 & -1 \\ 5 & 1 & 0 \\ 0 & 1 & 3 \end{bmatrix}$

$$\begin{aligned}
 |A| &= \begin{vmatrix} 2 & 0 & -1 \\ 5 & 1 & 0 \\ 0 & 1 & 3 \end{vmatrix} \\
 &= 2(3 - 0) - 0(15 - 0) - 1(5 - 0) \\
 &= 6 - 0 - 5 \\
 &= 1 \neq 0
 \end{aligned}$$

$\therefore A^{-1}$  is exist.

Consider  $AA^{-1} = I$

$$\begin{bmatrix} 2 & 0 & -1 \\ 5 & 1 & 0 \\ 0 & 1 & 3 \end{bmatrix} A^{-1} = \begin{bmatrix} 1 & 0 & 0 \\ 0 & 1 & 0 \\ 0 & 0 & 1 \end{bmatrix}$$

$$\text{By } R_1 \rightarrow 3R_1 \quad \begin{bmatrix} 6 & 0 & -3 \\ 5 & 1 & 0 \\ 0 & 1 & 3 \end{bmatrix} A^{-1} = \begin{bmatrix} 3 & 0 & 0 \\ 0 & 1 & 0 \\ 0 & 0 & 1 \end{bmatrix}$$

$$\text{By } R_1 \rightarrow R_1 - R_2 \quad \begin{bmatrix} 1 & -1 & -3 \\ 5 & 1 & 0 \\ 0 & 1 & 3 \end{bmatrix} A^{-1} = \begin{bmatrix} 3 & -1 & 0 \\ 0 & 1 & 0 \\ 0 & 0 & 1 \end{bmatrix}$$

$$\text{By } R_2 \rightarrow R_2 - 5R_1 \quad \begin{bmatrix} 1 & -1 & -3 \\ 0 & 6 & 15 \\ 0 & 1 & 3 \end{bmatrix} A^{-1} = \begin{bmatrix} 3 & -1 & 0 \\ -15 & 6 & 0 \\ 0 & 0 & 1 \end{bmatrix}$$

$$\text{By } R_2 \leftrightarrow R_3 \quad \begin{bmatrix} 1 & -1 & -3 \\ 0 & 1 & 3 \\ 0 & 6 & 16 \end{bmatrix} A^{-1} = \begin{bmatrix} 3 & -1 & 0 \\ 0 & 0 & 1 \\ -15 & 6 & 0 \end{bmatrix}$$

$$\text{By } R_1 \rightarrow R_1 + R_2 \text{ and } R_3 \rightarrow R_3 - 6R_2 \quad \begin{bmatrix} 1 & 0 & 0 \\ 0 & 1 & 3 \\ 0 & 0 & -3 \end{bmatrix} A^{-1} = \begin{bmatrix} -3 & -1 & 1 \\ 0 & 0 & 1 \\ -15 & 6 & -6 \end{bmatrix}$$

$$\text{By } R_3 \rightarrow \left(\frac{1}{3}\right) R_3 \quad A^{-1} = \begin{bmatrix} 1 & 0 & 0 \\ 0 & 1 & 3 \\ 0 & 0 & 1 \end{bmatrix} = \begin{bmatrix} 3 & -1 & 1 \\ 0 & 0 & 1 \\ 5 & -2 & 2 \end{bmatrix}$$

$$\text{By } R_2 \rightarrow R_2 - R_3 \quad A^{-1} = \begin{bmatrix} 1 & 0 & 0 \\ 0 & 1 & 0 \\ 0 & 0 & 1 \end{bmatrix} = \begin{bmatrix} 3 & -1 & 1 \\ -15 & 6 & -5 \\ 5 & -2 & 2 \end{bmatrix}$$

$$IA^{-1} = \begin{bmatrix} 3 & -1 & 1 \\ -15 & 6 & -5 \\ 5 & -2 & 2 \end{bmatrix}$$

$$A^{-1} = \begin{bmatrix} 3 & -1 & 1 \\ -15 & 6 & -5 \\ 5 & -2 & 2 \end{bmatrix}$$

2) **Inverse of a non singular matrix by Adjoint Method:** This method can be directly used for finding the inverse. However, for understanding this method we should know the definitions of minor and co-factor.

**Definition:** Minor of an element  $a_{ij}$  of matrix is the determinant obtained by ignoring  $i^{\text{th}}$  row and  $j^{\text{th}}$  column in which the element  $a_{ij}$  lies. Minor of an element  $a_{ij}$  is denoted by  $M_{ij}$ .

**Definition:** Cofactor of an element  $a_{ij}$  of matrix is given by  $A_{ij} = (-1)^{i+j}M_{ij}$ , where  $M_{ij}$  is minor of the element  $a_{ij}$ . Cofactor of an element  $a_{ij}$  is denoted  $A_{ij}$ .

### Adjoint of a Matrix:

The adjoint of a square matrix is defined as the transpose of the cofactor matrix of A.

The adjoint of a matrix A is denoted by  $\text{adj}A$ .

**For Example:** If A is a square matrix of order 3 then the matrix of its cofactors is

$$\begin{bmatrix} A_{11} & A_{12} & A_{13} \\ A_{21} & A_{22} & A_{23} \\ A_{31} & A_{32} & A_{33} \end{bmatrix}$$

and the required adjoint of A is the transpose of the above matrix. Hence

$$\text{adj}A = \begin{bmatrix} A_{11} & A_{21} & A_{31} \\ A_{12} & A_{22} & A_{32} \\ A_{13} & A_{23} & A_{33} \end{bmatrix}$$

If  $A = [a_{ij}]_{m \times m}$  is non singular square matrix then the inverse of matrix exists and given by

$$A^{-1} = \frac{1}{|A|} \text{adj}(A)$$

## SOLVED EXAMPLES

1) Find the cofactor matrix of  $A = \begin{bmatrix} 2 & 4 \\ -1 & 7 \end{bmatrix}$

**Solution:** Here  $a_{11} = 2, a_{12} = 4, a_{21} = -1, a_{22} = 7$

Minor of  $a_{11}$  i.e.,  $M_{11} \quad \therefore A_{11} = (-1)^{1+1}M_{11} = (-1)^2 7 = 7$

Similarly we can find  $M_{12} = -1$ , and  $A_{12} = (-1)^{1+2}M_{12} = -1(-1) = 1$

$M_{21} = 4$ , and  $A_{21} = (-1)^{2+1}M_{21} = -1(4) = -4$

$M_{22} = 2$ , and  $A_{22} = (-1)^{2+2}M_{22} = 1(2) = 2$

$\therefore$  Required cofactors are 7, 1, -4, 2

$\therefore$  Cofactor Matrix  $= [A_{ij}]_{2 \times 2} = \begin{bmatrix} 7 & 1 \\ -4 & 2 \end{bmatrix}$

2) Find the adjoint of  $A = \begin{bmatrix} 2 & -3 \\ 4 & -6 \end{bmatrix}$

**Solution:** Minor of  $a_{11} = M_{11} = -6$

$\therefore A_{11} = (-1)^{1+1}M_{11} = 1(-6) = -6$

Minor of  $a_{12} = M_{12} = 4$

$\therefore A_{12} = (-1)^{1+2}M_{12} = -1(4) = -4$

Minor of  $a_{21} = M_{21} = -3$

$\therefore A_{21} = (-1)^{2+1}M_{21} = -1(-3) = 3$

Minor of  $a_{22} = M_{22} = 2$

$\therefore A_{22} = (-1)^{2+2}M_{22} = 1(2) = 2$

$\therefore$  Cofactor of matrix  $[A_{ij}]_{2 \times 2} = \begin{bmatrix} -6 & -4 \\ 3 & 2 \end{bmatrix}$

$\text{adj}(A) = [A_{ij}]^T = \begin{bmatrix} -6 & 3 \\ -4 & 2 \end{bmatrix}$

3) If  $A = \begin{bmatrix} 2 & -2 \\ 4 & 3 \end{bmatrix}$  then find  $A^{-1}$  by the adjoint method.

**Solution:** Given  $A = \begin{bmatrix} 2 & -2 \\ 4 & 3 \end{bmatrix}$

$$|A| = \begin{vmatrix} 2 & -2 \\ 4 & 3 \end{vmatrix} = 6 + 8 = 14 \neq 0$$

$\therefore A^{-1}$  is exist.

$M_{11} = 3 \quad \therefore A_{11} = (-1)^{1+1}M_{11} = 1(3) = 3$

$$M_{12} = 4, \quad \therefore A_{12} = (-1)^{1+2}M_{12} = -1(4) = -4$$

$$M_{21} = -2, \quad \therefore A_{21} = (-1)^{2+1}M_{21} = -1(-2) = 2$$

$$M_{22} = 2, \quad \therefore A_{22} = (-1)^{2+2}M_{22} = 1(2) = 2$$

$$\therefore \text{Cofactor matrix } [A_{ij}]_{2 \times 2} = \begin{bmatrix} 3 & -4 \\ 2 & 2 \end{bmatrix}$$

$$\text{adj}(A) = [A_{ij}]^T = \begin{bmatrix} 3 & 2 \\ -4 & 2 \end{bmatrix}$$

$$A^{-1} = \frac{1}{|A|} \text{adj}(A)$$

$$A^{-1} = \frac{1}{14} \begin{bmatrix} 3 & 2 \\ -4 & 2 \end{bmatrix}$$

4) If  $A = \begin{bmatrix} 2 & -1 & 1 \\ -1 & 2 & -1 \\ 1 & -1 & 2 \end{bmatrix}$  then find  $A^{-1}$  by the adjoint method.

**Solution:** Given  $A = \begin{bmatrix} 2 & -1 & 1 \\ -1 & 2 & -1 \\ 1 & -1 & 2 \end{bmatrix}$

$$|A| = \begin{vmatrix} 2 & -1 & 1 \\ -1 & 2 & -1 \\ 1 & -1 & 2 \end{vmatrix} = 2(4 - 1) + 1(-2 + 1) + 1(1 - 2)$$

$$= 6 - 1 - 1 = 4 \neq 0$$

$$\therefore A^{-1} \text{ exists.}$$

For the given matrix A

$$\therefore A_{11} = (-1)^{1+1} \begin{vmatrix} 2 & -1 \\ -1 & 2 \end{vmatrix} = 1(4 - 1) = 3$$

$$\therefore A_{12} = (-1)^{1+2} \begin{vmatrix} -1 & -1 \\ 1 & 2 \end{vmatrix} = -1(-2 + 1) = 1$$

$$\therefore A_{13} = (-1)^{1+3} \begin{vmatrix} -1 & 2 \\ 1 & -1 \end{vmatrix} = 1(1 - 2) = -1$$

$$\therefore A_{21} = (-1)^{2+1} \begin{vmatrix} -1 & 1 \\ -1 & 2 \end{vmatrix} = -1(-2 + 1) = 1$$



$$\therefore A_{22} = (-1)^{2+2} \begin{vmatrix} 2 & 1 \\ 1 & 2 \end{vmatrix} = 1(4 - 1) = 3$$

$$\therefore A_{23} = (-1)^{2+3} \begin{vmatrix} 2 & -1 \\ 1 & -1 \end{vmatrix} = -1(-2 + 1) = 1$$

$$\therefore A_{31} = (-1)^{3+1} \begin{vmatrix} -1 & 1 \\ 2 & -1 \end{vmatrix} = 1(1 - 2) = -1$$

$$\therefore A_{32} = (-1)^{3+2} \begin{vmatrix} 2 & 1 \\ -1 & -1 \end{vmatrix} = -1(-2 + 1) = 1$$

$$\therefore A_{33} = (-1)^{3+3} \begin{vmatrix} 2 & -1 \\ -1 & 2 \end{vmatrix} = 1(4 - 1) = 3$$

$$\therefore \text{Cofactor matrix } [A_{ij}]_{3 \times 3} = \begin{bmatrix} 3 & 1 & -1 \\ 1 & 3 & 1 \\ -1 & 1 & 3 \end{bmatrix}$$

$$\text{adj}(A) = [A_{ij}]^T = \begin{bmatrix} 3 & 1 & -1 \\ 1 & 3 & 1 \\ -1 & 1 & 3 \end{bmatrix}$$

$$A^{-1} = \frac{1}{|A|} \text{adj } A$$

$$A^{-1} = \frac{1}{4} \begin{bmatrix} 3 & 1 & -1 \\ 1 & 3 & 1 \\ -1 & 1 & 3 \end{bmatrix}$$

### EXERCISE 2.5

1) Apply the given elementary transformation on each of the following matrices.

i)  $\begin{bmatrix} 3 & -4 \\ 2 & 2 \end{bmatrix}$ ,  $R_1 \leftrightarrow R_2$

ii)  $\begin{bmatrix} 2 & 4 \\ 1 & -5 \end{bmatrix}$ ,  $C_1 \leftrightarrow C_2$

iii)  $\begin{bmatrix} 3 & 1 & -1 \\ 1 & 3 & 1 \\ -1 & 1 & 3 \end{bmatrix}$   $3R_2$  and  $C_2 \rightarrow C_2 - 4C_1$

2) Transform  $\begin{bmatrix} 1 & -1 & 2 \\ 2 & 1 & 3 \\ 3 & 2 & 4 \end{bmatrix}$  into an upper triangular matrix by suitable row transformations.

3) Find the cofactor of the following matrices

i)  $\begin{bmatrix} 1 & 2 \\ 5 & -8 \end{bmatrix}$       ii)  $\begin{bmatrix} 5 & 8 & 7 \\ -1 & -2 & 1 \\ -2 & 1 & 1 \end{bmatrix}$

4) Find the adjoint of the following matrices

i)  $\begin{bmatrix} 2 & -3 \\ 3 & 5 \end{bmatrix}$       ii)  $\begin{bmatrix} 1 & -1 & 2 \\ -2 & 3 & 5 \\ -2 & 0 & -1 \end{bmatrix}$

5) Find the inverse of the following matrices by the adjoint method

i)  $\begin{bmatrix} 3 & -1 \\ 2 & -1 \end{bmatrix}$       ii)  $\begin{bmatrix} 2 & -2 \\ 4 & 5 \end{bmatrix}$       iii)  $\begin{bmatrix} 1 & 2 & 3 \\ 0 & 2 & 4 \\ 0 & 0 & 5 \end{bmatrix}$

6) Find the inverse of the following matrices by the transformation method.

i)  $\begin{bmatrix} 1 & 2 \\ 2 & -1 \end{bmatrix}$       ii)  $\begin{bmatrix} 2 & 0 & -1 \\ 5 & 1 & 0 \\ 0 & 1 & 3 \end{bmatrix}$

7) Find the inverse  $A = \begin{bmatrix} 1 & 0 & 1 \\ 0 & 2 & 3 \\ 1 & 2 & 1 \end{bmatrix}$  by elementary column transformation.

8) Find the inverse  $\begin{bmatrix} 1 & 2 & 3 \\ 1 & 1 & 5 \\ 2 & 4 & 7 \end{bmatrix}$  of by the elementary row transformation.

9) If  $A = \begin{bmatrix} 1 & 0 & 1 \\ 0 & 2 & 3 \\ 1 & 2 & 1 \end{bmatrix}$  and  $B = \begin{bmatrix} 1 & 2 & 3 \\ 1 & 1 & 5 \\ 2 & 4 & 7 \end{bmatrix}$  then find matrix X such that  $XA = B$

10) Find matrix X, If  $AX = B$  where  $A = \begin{bmatrix} 1 & 2 & 3 \\ -1 & 1 & 2 \\ 1 & 2 & 4 \end{bmatrix}$  and  $B = \begin{bmatrix} 1 \\ 2 \\ 3 \end{bmatrix}$

## 2.7 Applications of Matrices:

To find a solution of simultaneous linear equations.

Consider the following pair of simultaneous linear equations in two variables.

$$\left. \begin{array}{l} a_1x + b_1y = c_1 \\ a_2x + b_2y = c_2 \end{array} \right\} \dots\dots\dots (i)$$

Now consider the  $2 \times 2$  matrix formed by coefficient of  $x$  and  $y$

$$A = \begin{bmatrix} a_1 & b_1 \\ a_2 & b_2 \end{bmatrix}, \quad X = \begin{bmatrix} x \\ y \end{bmatrix}, \quad B = \begin{bmatrix} c_1 \\ c_2 \end{bmatrix}$$

Now consider the following matrix equation  $AX = B$

$$\begin{bmatrix} a_1 & b_1 \\ a_2 & b_2 \end{bmatrix} \begin{bmatrix} x \\ y \end{bmatrix} = \begin{bmatrix} c_1 \\ c_2 \end{bmatrix}$$

$$\begin{bmatrix} a_1x + b_1y \\ a_2x + b_2y \end{bmatrix} = \begin{bmatrix} c_1 \\ c_2 \end{bmatrix} \quad \dots\dots\dots (ii)$$

$$\therefore a_1x + b_1y = c_1$$

$$a_2x + b_2y = c_2$$

Hence the matrix equation (ii) is equivalent to pair of simultaneous linear equations given by (i)

$$\therefore \text{Matrix form of } a_1x + b_1y = c_1$$

$$a_2x + b_2y = c_2 \text{ is}$$

$$\begin{bmatrix} a_1 & b_1 \\ a_2 & b_2 \end{bmatrix} \begin{bmatrix} x \\ y \end{bmatrix} = \begin{bmatrix} c_1 \\ c_2 \end{bmatrix}$$

Similarly suppose we have three simultaneous equations in three variables

$$a_1x + b_1y + c_1z = d_1$$

$$a_2x + b_2y + c_2z = d_2$$

$$a_3x + b_3y + c_3z = d_3$$

This can be summarized by the matrix equation

$$\begin{bmatrix} a_1 & b_1 & c_1 \\ a_2 & b_2 & c_2 \\ a_3 & b_3 & c_3 \end{bmatrix} \begin{bmatrix} x \\ y \\ z \end{bmatrix} = \begin{bmatrix} d_1 \\ d_2 \\ d_3 \end{bmatrix}$$

**For example:** Write the following linear equations in the form of a matrix equation.

1)  $3x + 5y = 2$

$$-2x + y = 5$$

**Solution :**  $A = \begin{bmatrix} 3 & 5 \\ -2 & 1 \end{bmatrix}, B = \begin{bmatrix} 2 \\ 5 \end{bmatrix}, X = \begin{bmatrix} x \\ y \end{bmatrix}$

$$AX = B$$

$$\begin{bmatrix} 3 & 5 \\ -2 & 1 \end{bmatrix} \begin{bmatrix} x \\ y \end{bmatrix} = \begin{bmatrix} 2 \\ 5 \end{bmatrix}$$

2)  $3x + 2y - z = 4$

$$7x - 2y - 2z = 3$$

$$2x - 3y + 5z = 4$$

**Solution:**  $A = \begin{bmatrix} 3 & 2 & -1 \\ 7 & -2 & -2 \\ 2 & -3 & 5 \end{bmatrix}$ ,  $X = \begin{bmatrix} x \\ y \\ z \end{bmatrix}$ ,  $B = \begin{bmatrix} 4 \\ 3 \\ 4 \end{bmatrix}$

$$AX = B$$

$$\begin{bmatrix} 3 & 2 & -1 \\ 7 & -2 & -2 \\ 2 & -3 & 5 \end{bmatrix} \begin{bmatrix} x \\ y \\ z \end{bmatrix} = \begin{bmatrix} 4 \\ 3 \\ 4 \end{bmatrix}$$

There are two methods for solving linear equations (I) Method of Inversion (II) Method of Reduction

**(I) Method of Inversion:** Consider a system of linear equations. Suppose we express it in the matrix form  $AX=B$ , where  $A$  is non singular ( $|A| \neq 0$ ). Then  $A$  has a unique inverse  $A^{-1}$ .

Pre multiplying  $AX=B$  by  $A^{-1}$ , we get

$$A^{-1}(AX) = A^{-1}B$$

$$(A^{-1}A)X = A^{-1}B$$

$$IX = A^{-1}B$$

$\therefore X = A^{-1}B$ . Thus, there is a unique solution to the given system of linear equations.

### SOLVED EXAMPLES

1) Solve the following equations by inversion matrix of inversion method

$$2x + 3y = 5$$

$$6x - 2y = 4$$

**Solution:**  $A = \begin{bmatrix} 2 & 3 \\ 6 & -2 \end{bmatrix}$ ,  $X = \begin{bmatrix} x \\ y \end{bmatrix}$ ,  $B = \begin{bmatrix} 5 \\ 4 \end{bmatrix}$ ,

Given equations can be written in matrix form as

$$AX = B$$

Pre-multiplying  $AX = B$  by  $A^{-1}$  we get

$$A^{-1}(AX) = A^{-1}B$$

$$(A^{-1}A)X = A^{-1}B$$

$$IX = A^{-1}B$$

$$X = A^{-1}B$$

First we find the inverse by  $A$  by row transformation

We write  $AA^{-1} = I$

$$\begin{bmatrix} 2 & 3 \\ 6 & -2 \end{bmatrix} A^{-1} = \begin{bmatrix} 1 & 0 \\ 0 & 1 \end{bmatrix}$$

$$\text{Using } R_1 \rightarrow \left(\frac{1}{2}\right) R_1 \quad \begin{bmatrix} 1 & \frac{3}{2} \\ 6 & -2 \end{bmatrix} \quad A^{-1} = \begin{bmatrix} \frac{1}{2} & 0 \\ 0 & 1 \end{bmatrix}$$

$$\text{Using } R_2 \rightarrow R_2 - 6R_1 \quad \begin{bmatrix} 1 & \frac{3}{2} \\ 0 & -11 \end{bmatrix} \quad A^{-1} = \begin{bmatrix} \frac{1}{2} & 0 \\ -3 & 1 \end{bmatrix}$$

$$\text{Using } R_2 \rightarrow \left(\frac{-1}{11}\right) R_2 \quad \begin{bmatrix} 1 & \frac{3}{2} \\ 0 & 1 \end{bmatrix} \quad A^{-1} = \begin{bmatrix} \frac{1}{2} & 0 \\ \frac{3}{11} & \frac{-1}{11} \end{bmatrix}$$

$$\text{Using } R_1 \rightarrow R_1 - \frac{3}{2} R_2 \quad \begin{bmatrix} 1 & 0 \\ 0 & 1 \end{bmatrix} \quad A^{-1} = \begin{bmatrix} \frac{2}{22} & \frac{3}{22} \\ \frac{3}{11} & \frac{-1}{11} \end{bmatrix}$$

$$A^{-1} = \frac{1}{11} \begin{bmatrix} 1 & \frac{3}{2} \\ 3 & -1 \end{bmatrix}$$

$$\therefore X = A^{-1}B = \frac{1}{11} \begin{bmatrix} 1 & \frac{3}{2} \\ 3 & -1 \end{bmatrix} \begin{bmatrix} 5 \\ 4 \end{bmatrix}$$

$$X = \frac{1}{11} \begin{bmatrix} 5+6 \\ 15-4 \end{bmatrix} = \frac{1}{11} \begin{bmatrix} 11 \\ 11 \end{bmatrix} = \begin{bmatrix} \frac{11}{11} \\ \frac{11}{11} \end{bmatrix}$$

$$\begin{bmatrix} x \\ y \end{bmatrix} = \begin{bmatrix} 1 \\ 1 \end{bmatrix}$$

$$\therefore x = 1, y = 1$$

Hence the solution of given linear equations are  $x = 1, y = 1$ .

2) Solve the following equations by the inversion method

$$x - y + z = 4$$

$$2x + y - 3z = 0$$

$$x + y + z = 2$$

**Solution:** The matrix equation is

$$\begin{bmatrix} 1 & -1 & 1 \\ 2 & 1 & -3 \\ 1 & 1 & 1 \end{bmatrix} \begin{bmatrix} x \\ y \\ z \end{bmatrix} = \begin{bmatrix} 4 \\ 0 \\ 2 \end{bmatrix}$$

$$AX=B$$

Pre-multiplying  $AX = B$  by  $A^{-1}$  we get

$$A^{-1}(AX) = A^{-1}B$$

$$(A^{-1}A)X = A^{-1}B$$

$$IX = A^{-1}B$$

$$X = A^{-1}B$$

First we find the inverse of A by adjoint method

$$|A| = \begin{vmatrix} 1 & -1 & 1 \\ 2 & 1 & -3 \\ 1 & 1 & 1 \end{vmatrix}$$

$$|A| = 1(1 + 3) + 1(2 + 3) + 1(2 - 1)$$

$$= 4 + 5 + 1$$

$$= 10 \neq 0$$

$A^{-1}$  is exist

$$A = \begin{bmatrix} 1 & -1 & 1 \\ 2 & 1 & -3 \\ 1 & 1 & 1 \end{bmatrix}$$

$$M_{11} = \begin{vmatrix} 1 & -3 \\ 1 & 1 \end{vmatrix} = 1 + 3 = 4 \quad \therefore A_{11} = (-1)^2 M_{11} = 1(4) = 4$$

$$M_{12} = \begin{vmatrix} 2 & -3 \\ 1 & 1 \end{vmatrix} = 2 + 3 = 5 \quad \therefore A_{12} = (-1)^3 M_{12} = (-1)(5) = -5$$

$$M_{13} = \begin{vmatrix} 2 & 1 \\ 1 & 1 \end{vmatrix} = 2 - 1 = 1 \quad \therefore A_{13} = (-1)^4 M_{13} = 1(1) = 1$$

$$M_{21} = \begin{vmatrix} -1 & 1 \\ 1 & 1 \end{vmatrix} = -1 - 1 = -2 \quad \therefore A_{21} = (-1)^3 M_{21} = (-1)(-2) = 2$$

$$M_{22} = \begin{vmatrix} 1 & 1 \\ 1 & 1 \end{vmatrix} = 1 - 1 = 0 \quad \therefore A_{22} = (-1)^4 M_{22} = 1(0) = 0$$

$$M_{23} = \begin{vmatrix} 1 & -1 \\ 1 & 1 \end{vmatrix} = 1 + 1 = 2 \quad \therefore A_{23} = (-1)^5 M_{23} = (-1)(2) = -2$$

$$M_{31} = \begin{vmatrix} -1 & 1 \\ 1 & -3 \end{vmatrix} = 3 - 1 = 2 \quad \therefore A_{31} = (-1)^4 M_{31} = 1(2) = 2$$

$$M_{32} = \begin{vmatrix} 1 & 1 \\ 2 & -3 \end{vmatrix} = -3 - 2 = -5 \quad \therefore A_{32} = (-1)^5 M_{32} = (-1)(-5) = 5$$

$$M_{33} = \begin{vmatrix} 1 & -1 \\ 2 & 1 \end{vmatrix} = 1 + 2 = 3 \quad \therefore A_{33} = (-1)^6 M_{33} = 1(3) = 3$$

$$\therefore [A_{ij}] = \begin{bmatrix} 4 & -5 & 1 \\ 2 & 0 & -2 \\ 2 & 5 & 3 \end{bmatrix}$$

$$\begin{aligned} \text{adj}(A) &= [A_{ij}]^T \\ &= \begin{bmatrix} 4 & 2 & 2 \\ -5 & 0 & 5 \\ 1 & -2 & 3 \end{bmatrix} \end{aligned}$$

$$\begin{aligned} A^{-1} &= \frac{1}{|A|} \text{Adj}(A) \\ &= \frac{1}{10} \begin{bmatrix} 4 & 2 & 2 \\ -5 & 0 & 5 \\ 1 & -2 & 3 \end{bmatrix} \end{aligned}$$

$$\begin{aligned} X &= A^{-1}B \\ &= \frac{1}{10} \begin{bmatrix} 4 & 2 & 2 \\ -5 & 0 & 5 \\ 1 & -2 & 3 \end{bmatrix} \begin{bmatrix} 4 \\ 0 \\ 2 \end{bmatrix} \\ &= \frac{1}{10} \begin{bmatrix} 16+0+4 \\ -20+0+10 \\ 4+0+6 \end{bmatrix} \\ &= \frac{1}{10} \begin{bmatrix} 20 \\ -10 \\ 10 \end{bmatrix} = \begin{bmatrix} 2 \\ -1 \\ 1 \end{bmatrix} \\ &= \begin{bmatrix} x \\ y \\ z \end{bmatrix} = \begin{bmatrix} 2 \\ -1 \\ 1 \end{bmatrix} \end{aligned}$$

$$\therefore x = 2, y = -1, z = 1$$

## (II) Method of Reduction:

Here we start by writing the given linear equations as the matrix equation  $AX = B$ . Then we perform suitable row transformations on the matrix  $A$ . Using the row transformations, we reduce matrix  $A$  into an upper triangular matrix or lower triangular matrix. The same row transformations are performed simultaneously on matrix  $B$ .

After this, we rewrite the equations in the form of a system of linear equations. Now they are in such a form that they can be easily solved by elimination method. The required solution is obtained in this way.

**Solved Examples**

1) Solve the equations  $2x - y = -2$  and  $3x + 4y = 3$  by the method of reduction.

**Solution:** The given equations can be write as

$$2x - y = -2$$

$$3x + 4y = 3$$

Hence the matrix equation is  $AX = B$

$$\begin{bmatrix} 2 & -1 \\ 3 & 4 \end{bmatrix} \begin{bmatrix} x \\ y \end{bmatrix} = \begin{bmatrix} -2 \\ 3 \end{bmatrix}$$

By  $R_1 \leftrightarrow R_2$

$$\begin{bmatrix} 3 & 4 \\ 2 & -1 \end{bmatrix} \begin{bmatrix} x \\ y \end{bmatrix} = \begin{bmatrix} 3 \\ -2 \end{bmatrix}$$

By  $R_1 \leftrightarrow R_1 - R_2$

$$\begin{bmatrix} 1 & 5 \\ 2 & -1 \end{bmatrix} \begin{bmatrix} x \\ y \end{bmatrix} = \begin{bmatrix} 5 \\ -2 \end{bmatrix}$$

By  $R_2 \leftrightarrow R_2 - 2R_1$

$$\begin{bmatrix} 1 & 5 \\ 0 & -11 \end{bmatrix} \begin{bmatrix} x \\ y \end{bmatrix} = \begin{bmatrix} 5 \\ -12 \end{bmatrix}$$

We write equations as

$$x + 5y = 5 \quad \text{----- (1)}$$

$$-11y = -12 \quad \text{----- (2)}$$

$$\text{from (2), } y = \frac{12}{11} \quad \text{----- (3)}$$

Put  $y = \frac{12}{11}$  in equation (1) to get

$$x + 5 \times \left(\frac{12}{11}\right) = 5$$

$$x = 5 - \frac{60}{11} = \frac{55 - 60}{11} = \frac{-5}{11}$$

$$\therefore x = \frac{-5}{11}, y = \frac{12}{11}$$



2) Express the following equations in matrix form and solve them by the method of reduction

$$x - y + z = 1, 2x - y = 1, 3x + 3y - 4z = 2.$$

**Solution:** The given equations can be write as

$$x - y + z = 1$$

$$2x - y = 1$$

$$3x + 3y - 4z = 2$$

Hence the matrix equation is  $AX = B$

$$\therefore \begin{bmatrix} 1 & -1 & 1 \\ 2 & -1 & 0 \\ 3 & 3 & -4 \end{bmatrix} \begin{bmatrix} x \\ y \\ z \end{bmatrix} = \begin{bmatrix} 1 \\ 1 \\ 2 \end{bmatrix}$$

$$\text{By } R_2 \rightarrow R_2 - 2R_1 \quad \begin{bmatrix} 1 & -1 & 1 \\ 0 & 1 & -2 \\ 3 & 3 & -4 \end{bmatrix} \begin{bmatrix} x \\ y \\ z \end{bmatrix} = \begin{bmatrix} 1 \\ -1 \\ 2 \end{bmatrix}$$

$$\text{By } R_3 \rightarrow R_3 - 3R_1 \quad \begin{bmatrix} 1 & -1 & 1 \\ 0 & 1 & -2 \\ 0 & 6 & -7 \end{bmatrix} \begin{bmatrix} x \\ y \\ z \end{bmatrix} = \begin{bmatrix} 1 \\ -1 \\ -1 \end{bmatrix}$$

$$\text{By } R_3 \rightarrow R_3 - 6R_2 \quad \begin{bmatrix} 1 & -1 & 1 \\ 0 & 1 & -2 \\ 0 & 0 & 5 \end{bmatrix} \begin{bmatrix} x \\ y \\ z \end{bmatrix} = \begin{bmatrix} 1 \\ -1 \\ 5 \end{bmatrix}$$

We write equations as

$$x - y + z = 1 \text{ ----- (1)}$$

$$y - 2z = -1 \text{ ----- (2)}$$

$$5z = 5 \text{ ----- (3)}$$

From (3),  $z = 1$

$$\text{Put } z = 1 \text{ in equation (2) } y - 2(1) = -1 \quad \therefore y = 2 - 1 = 1$$

$$\text{Put } y = 1, z = 1 \text{ in equation (1) } x - 1 + 1 = 1, \quad \therefore x = 1$$

$$\therefore x = 1, y = 1, z = 1$$

### EXERCISE 2.6

1) Solve the following equations by method of inversion.

i)  $x + 2y = 2, 2x + 3y = 3$

ii)  $2x + y = 5, 3x + 5y = -3$

iii)  $2x - y + z = 1, x + 2y + 3z = 8$  and  $3x + y - 4z = 1$

iv)  $x + y + z = 1, x - y + z = 2$  and  $x + y - z = 3$

- 2) Express the following equations in matrix form and solve them by method of reduction.
- i)  $x + 3y = 2, 3x + 5y = 4$   
 ii)  $3x - y = 1, 4x + y = 6$   
 iii)  $x + 2y + z = 8, 2x + 3y - z = 11$  and  $3x - y - 2z = 5$   
 iv)  $x + y + z = 1, 2x + 3y + 2z = 2$  and  $x + y + 2z = 4$
- 3) The total cost of 3 T.V. and 2 V.C.R. is Rs. 35000. The shopkeeper wants profit of Rs. 1000 per T.V. and Rs. 500 per V.C.R. He sell 2 T.V. and 1 V.C.R. and he gets total revenue as Rs. 21500. Find the cost and selling price of T.V and V.C.R.
- 4) The sum of the cost of one Economic book, one Co-operation book and one account book is Rs. 420. The total cost of an Economic book, 2 Co-operation books and an Account book is Rs. 480. Also the total cost of an Economic book, 3 Co-operation book and 2 Account books is Rs. 600. Find the cost of each book.



### Let's Remember

- **Scalar Multiplication of a matrix:**

If  $A = [a_{ij}]_{m \times n}$  is a matrix and  $k$  is a scalar, then  $kA = [ka_{ij}]$ .

- **Addition of two matrices:**

Matrices  $A = [a_{ij}]$  and  $B = [b_{ij}]$  are said to conformable for addition if orders of  $A$  and  $B$  are same.

Then  $A + B = [a_{ij} + b_{ij}]$ . The order of  $A + B$  is the same as the order of  $A$  and  $B$ .

- **Multiplication of two matrices:**

$A$  and  $B$  are said to be conformable for multiplication if the number of columns of  $A$  is equal to the number of rows of  $B$ .

That is, if  $A = [a_{ik}]_{m \times p}$  and  $B = [b_{kj}]_{p \times n}$ , then  $AB$  is defined and  $AB = [c_{ij}]_{m \times n}$ ,

$$\text{where } c_{ij} = \sum_{k=1}^p a_{ik} b_{kj} \quad \begin{array}{l} i = 1, 2, \dots, m \\ j = 1, 2, \dots, n. \end{array}$$

- If  $A = [a_{ij}]_{m \times n}$  is any matrix, then the transpose of  $A$  is denoted by  $A^T = B = [b_{ij}]_{n \times m}$  and  $b_{ij} = a_{ji}$
- If  $A$  is a square matrix, then
  - $A + A^T$  is a symmetric matrix
  - $A - A^T$  is a skew-symmetric matrix.
- Every square matrix  $A$  can be expressed as the sum of a symmetric and a skew-symmetric matrix as
 
$$A = \frac{1}{2} [A + A^T] + \frac{1}{2} [A - A^T]$$
- **Elementary Transformations:**
  - Interchange of any two rows or any two columns
  - Multiplication of the elements of any row or column by a non zero scalar
  - Adding the scalar multiples of all the elements of any row (column) to the corresponding elements of any other row (column).

- If A and B are two square matrices of the same order such that  $AB = BA = I$ , then A and B are inverses of each other. A is denoted by  $B^{-1}$  and B is denoted by  $A^{-1}$ .
- For finding the inverse of A, if row transformation are to be used then we consider  $AA^{-1} = I$  and if column transformation are to be used then we consider  $A^{-1}A = I$ .
- For finding the inverse of any nonsingular square matrix, two methods can be used  
i) Elementary transformation method.      ii) Adjoint Method.
- A system of linear equations can be solved using matrices. The two methods are  
i) Method of inversion.                      ii) Method of reduction (Row transformations).

## MISCELLANEOUS EXERCISE - 2

### I. Choose the correct alternative.

- 1) If  $AX = B$ , where  $A = \begin{bmatrix} -1 & 2 \\ 2 & -1 \end{bmatrix}$ ,  $B = \begin{bmatrix} 1 \\ 1 \end{bmatrix}$  then  $X = \dots\dots$
- a)  $\begin{bmatrix} 3 \\ 5 \\ 3 \\ 7 \end{bmatrix}$       b)  $\begin{bmatrix} 7 \\ 3 \\ 5 \\ 3 \end{bmatrix}$       c)  $\begin{bmatrix} 1 \\ 1 \end{bmatrix}$       d)  $\begin{bmatrix} 1 \\ 2 \end{bmatrix}$
- 2) The matrix  $\begin{bmatrix} 8 & 0 & 0 \\ 0 & 8 & 0 \\ 0 & 0 & 8 \end{bmatrix}$  is .....
- a) Identity Matrix      b) scalar matrix      c) null matrix      d) diagonal matrix
- 3) The matrix  $\begin{bmatrix} 0 & 0 & 0 \\ 0 & 0 & 0 \\ 0 & 0 & 0 \end{bmatrix}$  is .....
- a) Identity matrix      b) diagonal matrix      c) scalar matrix      d) null matrix
- 4) If  $A = \begin{bmatrix} a & 0 & 0 \\ 0 & a & 0 \\ 0 & 0 & a \end{bmatrix}$ , then  $|\text{adj.}A| = \dots\dots\dots$
- a)  $a^{12}$       b)  $a^9$       c)  $a^6$       d)  $a^{-3}$
- 5) Adjoint of  $\begin{bmatrix} 2 & -3 \\ 4 & -6 \end{bmatrix}$  is .....
- a)  $\begin{bmatrix} -6 & 3 \\ -4 & 2 \end{bmatrix}$       b)  $\begin{bmatrix} 6 & 3 \\ -4 & 2 \end{bmatrix}$       c)  $\begin{bmatrix} -6 & -3 \\ 4 & 2 \end{bmatrix}$       d)  $\begin{bmatrix} -6 & 3 \\ 4 & -2 \end{bmatrix}$

- 6) If  $A = \text{diag. } [d_1, d_2, d_3, \dots, d_n]$ , where  $d_i \neq 0$ , for  $i = 1, 2, 3, \dots, n$  then  $A^{-1} = \dots\dots\dots$   
 a)  $\text{diag.}[1/d_1, 1/d_2, 1/d_3, \dots, 1/d_n]$     b)  $D$     c)  $I$     d)  $O$
- 7) If  $A^2 + mA + nI = O$  &  $n \neq 0, |A| \neq 0$ , then  $A^{-1} = \dots\dots\dots$   
 a)  $\frac{-1}{m}(A + nI)$     b)  $\frac{-1}{n}(A + mI)$     c)  $\frac{-1}{n}(I + mA)$     d)  $(A + mnI)$
- 8) If a  $3 \times 3$  matrix  $B$  has its inverse equal to  $B$ , then  $B^2 = \dots\dots\dots$   
 a)  $\begin{bmatrix} 0 & 1 & 1 \\ 0 & 1 & 0 \\ 1 & 0 & 1 \end{bmatrix}$     b)  $\begin{bmatrix} 1 & 1 & 1 \\ 1 & 1 & 1 \\ 1 & 0 & 1 \end{bmatrix}$     c)  $\begin{bmatrix} 1 & 0 & 1 \\ 0 & 1 & 0 \\ 0 & 0 & 0 \end{bmatrix}$     d)  $\begin{bmatrix} 1 & 0 & 0 \\ 0 & 1 & 0 \\ 0 & 0 & 1 \end{bmatrix}$
- 9) If  $A = \begin{bmatrix} \alpha & 4 \\ 4 & \alpha \end{bmatrix}$  &  $|A^3| = 729$  then  $\alpha = \dots\dots\dots$   
 a)  $\pm 3$     b)  $\pm 4$     c)  $\pm 5$     d)  $\pm 6$
- 10) If  $A$  and  $B$  square matrices of order  $n \times n$  such that  $A^2 - B^2 = (A - B)(A + B)$ , then which of the following will be always true ?  
 a)  $AB = BA$     b) either of  $A$  or  $B$  is a zero matrix  
 c) either of  $A$  and  $B$  is an identity matrix    d)  $A = B$
- 11) If  $A = \begin{bmatrix} 2 & 5 \\ 1 & 3 \end{bmatrix}$  then  $A^{-1} = \dots\dots\dots$   
 a)  $\begin{bmatrix} 3 & -5 \\ 1 & 2 \end{bmatrix}$     b)  $\begin{bmatrix} 3 & -5 \\ -1 & 2 \end{bmatrix}$     c)  $\begin{bmatrix} 3 & 5 \\ -1 & 2 \end{bmatrix}$     d)  $\begin{bmatrix} 3 & -5 \\ 1 & -2 \end{bmatrix}$
- 12) If  $A$  is a  $2 \times 2$  matrix such that  $A(\text{adj.}A) = \begin{bmatrix} 5 & 0 \\ 0 & 5 \end{bmatrix}$ , then  $|A| = \dots\dots\dots$   
 a) 0    b) 5    c) 10    d) 25
- 13) If  $A$  is a non singular matrix, then  $\det(A^{-1}) = \dots\dots\dots$   
 a) 1    b) 0    c)  $\det(A)$     d)  $1/\det(A)$
- 14) If  $A = \begin{bmatrix} 1 & 2 \\ -3 & -1 \end{bmatrix}$      $B = \begin{bmatrix} -1 & 0 \\ 1 & 5 \end{bmatrix}$  then  $AB =$   
 a)  $\begin{bmatrix} 1 & -10 \\ 1 & 20 \end{bmatrix}$     b)  $\begin{bmatrix} 1 & 10 \\ -1 & 20 \end{bmatrix}$     c)  $\begin{bmatrix} 1 & 10 \\ 1 & 20 \end{bmatrix}$     d)  $\begin{bmatrix} 1 & 10 \\ -1 & -20 \end{bmatrix}$
- 15) If  $x + y + z = 3, x + 2y + 3z = 4, x + 4y + 9z = 6$ , then  $(y, z) = \dots\dots\dots$   
 a)  $(-1, 0)$     b)  $(1, 0)$     c)  $(1, -1)$     d)  $(-1, 1)$

## II. Fill in the blanks.

- 1)  $A = \begin{bmatrix} 3 \\ 1 \end{bmatrix}$  is ..... matrix.
- 2) Order of matrix  $\begin{bmatrix} 2 & 1 & 1 \\ 5 & 1 & 8 \end{bmatrix}$  is .....
- 3) If  $A = \begin{bmatrix} 4 & x \\ 6 & 3 \end{bmatrix}$  is a singular matrix then  $x$  is .....
- 4) Matrix  $B = \begin{bmatrix} 0 & 3 & 1 \\ -3 & 0 & -4 \\ p & 4 & 0 \end{bmatrix}$  is skew symmetric then value of  $p$  is .....
- 5) If  $A = [a_{ij}]_{2 \times 3}$  and  $B = [b_{ij}]_{m \times 1}$  and  $AB$  is defined then  $m = \dots\dots\dots$
- 6) If  $A = \begin{bmatrix} 3 & -5 \\ 2 & 5 \end{bmatrix}$  then cofactor of  $a_{12}$  is .....
- 7) If  $A = [a_{ij}]_{m \times m}$  is non-singular matrix then  $A^{-1} = \frac{1}{\dots} \text{adj}(A)$
- 8)  $(A^T)^T = \dots\dots\dots$
- 9) If  $A = \begin{bmatrix} 2 & 1 \\ 1 & 1 \end{bmatrix}$  and  $A^{-1} = \begin{bmatrix} 1 & -1 \\ x & 2 \end{bmatrix}$  then  $x = \dots\dots\dots$
- 10) If  $a_1x + b_1y = c_1$  and  $a_2x + b_2y = c_2$ , then matrix form is  $\begin{bmatrix} \dots & \dots \\ \dots & \dots \end{bmatrix} \begin{bmatrix} x \\ y \end{bmatrix} = \begin{bmatrix} \dots \\ \dots \end{bmatrix}$

## III. State whether each of the following is True or False.

- 1) Single element matrix is row as well as column matrix.
- 2) Every scalar matrix is unit matrix.
- 3)  $A = \begin{bmatrix} 4 & 5 \\ 6 & 1 \end{bmatrix}$  is non singular matrix.
- 4) If  $A$  is symmetric then  $A = -A^T$
- 5) If  $AB$  and  $BA$  both are exist then  $AB = BA$
- 6) If  $A$  and  $B$  are square matrices of same order then  $(A + B)^2 = A^2 + 2AB + B^2$
- 7) If  $A$  and  $B$  are conformable for the product  $AB$  then  $(AB)^T = A^T B^T$
- 8) Singleton matrix is only row matrix.
- 9)  $A = \begin{bmatrix} 2 & 1 \\ 10 & 5 \end{bmatrix}$  is invertible matrix.
- 10)  $A(\text{adj}.A) = |A|I$ , where  $I$  is the unit matrix.

#### IV. Solve the following.

1) Find  $k$ , if  $\begin{bmatrix} 7 & 3 \\ 5 & k \end{bmatrix}$  is singular matrix.

2) Find  $x, y, z$  if  $\begin{bmatrix} 2 & x & 5 \\ 3 & 1 & z \\ y & 5 & 8 \end{bmatrix}$  is symmetric matrix.

3) If  $A = \begin{bmatrix} 1 & 5 \\ 7 & 8 \\ 9 & 5 \end{bmatrix}$ ,  $B = \begin{bmatrix} 2 & 4 \\ 1 & 5 \\ -8 & 6 \end{bmatrix}$ ,  $C = \begin{bmatrix} -2 & 3 \\ 1 & -5 \\ 7 & 8 \end{bmatrix}$  then show that  $(A+B) + C = A + (B+C)$

4) If  $A = \begin{bmatrix} 2 & 5 \\ 3 & 7 \end{bmatrix}$ ,  $B = \begin{bmatrix} 1 & 7 \\ -3 & 0 \end{bmatrix}$  Find matrix  $A - 4B + 7I$  where  $I$  is the unit matrix of order 2.

5) If  $A = \begin{bmatrix} 2 & -3 \\ 3 & -2 \\ -1 & 4 \end{bmatrix}$ ,  $B = \begin{bmatrix} -3 & 4 & 1 \\ 2 & -1 & -3 \end{bmatrix}$  Verify

i)  $(A + 2B^T)^T = A^T + 2B$

ii)  $(3A - 5B^T)^T = 3A^T - 5B$

6) If  $A = \begin{bmatrix} 1 & 2 & 3 \\ 2 & 4 & 6 \\ 1 & 2 & 3 \end{bmatrix}$ ,  $B = \begin{bmatrix} 1 & -1 & 1 \\ -3 & 2 & -1 \\ -2 & 1 & 0 \end{bmatrix}$  then show that  $AB$  and  $BA$  are both singular matrices.

7) If  $A = \begin{bmatrix} 3 & 1 \\ 1 & 5 \end{bmatrix}$ ,  $B = \begin{bmatrix} 1 & 2 \\ 5 & -2 \end{bmatrix}$ , verify  $|AB| = |A| |B|$

8) If  $A = \begin{bmatrix} 2 & -1 \\ -1 & 2 \end{bmatrix}$  then show that  $A^2 - 4A + 3I = 0$

9) If  $A = \begin{bmatrix} -3 & 2 \\ 2 & 4 \end{bmatrix}$ ,  $B = \begin{bmatrix} 1 & a \\ b & 0 \end{bmatrix}$  and  $(A + B)(A - B) = A^2 - B^2$ , find  $a$  and  $b$ .

10) If  $A = \begin{bmatrix} 1 & 2 \\ -1 & 3 \end{bmatrix}$ , then find  $A^3$

11) Find  $x, y, z$  if  $\left\{ 5 \begin{bmatrix} 0 & 1 \\ 1 & 0 \\ 1 & 1 \end{bmatrix} - \begin{bmatrix} 2 & 1 \\ 3 & -2 \\ 1 & 3 \end{bmatrix} \right\} \begin{bmatrix} 2 \\ 1 \end{bmatrix} = \begin{bmatrix} x-1 \\ y+1 \\ 2z \end{bmatrix}$

12) If  $A = \begin{bmatrix} 2 & -4 \\ 3 & -2 \\ 0 & 1 \end{bmatrix}$ ,  $B = \begin{bmatrix} 1 & -1 & 2 \\ -2 & 1 & 0 \end{bmatrix}$  then show that  $(AB)^T = B^T A^T$

13) If  $A = \begin{bmatrix} 1 & 0 & 0 \\ 2 & 1 & 0 \\ 3 & 3 & 1 \end{bmatrix}$  then reduce it to unit matrix by row transformation.

- 14) Two farmers Shantaram and Kantaram cultivate three crops rice, wheat and groundnut. The sale (in Rupees.) of these crops by both the farmers for the month of April and May 2016 is given below,

**April 2016 (In Rs.)**

	Rice	Wheat	Groundnut
Shantaram	15000	13000	12000
Kantaram	18000	15000	8000

**May 2016 (In Rs.)**

	Rice	Wheat	Groundnut
Shantaram	18000	15000	12000
Kantaram	21000	16500	16000

Find i) The total sale in rupees for two months of each farmer for each crop.

ii) the increase in sale from April to May for every crop of each farmer.

- 15) Check whether following matrices are invertible or not.

i)  $\begin{bmatrix} 1 & 0 \\ 0 & 1 \end{bmatrix}$       ii)  $\begin{bmatrix} 1 & 1 \\ 1 & 1 \end{bmatrix}$       iii)  $\begin{bmatrix} 3 & 4 & 3 \\ 1 & 1 & 0 \\ 1 & 4 & 5 \end{bmatrix}$       iv)  $\begin{bmatrix} 1 & 2 & 3 \\ 2 & 4 & 5 \\ 2 & 4 & 6 \end{bmatrix}$

- 16) Find inverse of the following matrices (if they exist) by elementary transformation.

i)  $\begin{bmatrix} 1 & -1 \\ 2 & 3 \end{bmatrix}$       ii)  $\begin{bmatrix} 2 & 1 \\ 7 & 4 \end{bmatrix}$       iii)  $\begin{bmatrix} 2 & -3 & 3 \\ 2 & 2 & 3 \\ 3 & -2 & 2 \end{bmatrix}$       iv)  $\begin{bmatrix} 2 & 0 & -1 \\ 5 & 1 & 0 \\ 0 & 1 & 3 \end{bmatrix}$

- 17) Find the inverse of  $\begin{bmatrix} 3 & 1 & 5 \\ 2 & 7 & 8 \\ 1 & 2 & 5 \end{bmatrix}$  by adjoint method.

- 18) Solve the following equations by method of inversion.

i)  $4x - 3y - 2 = 0$  ,  $3x - 4y + 6 = 0$

ii)  $x + y - z = 2$  ,  $x - 2y + z = 3$  and  $2x - y - 3z = -1$

iii)  $x - y + z = 4$  ,  $2x + y - 3z = 0$  and  $x + y + z = 2$

- 19) Solve the following equation by method of reduction.

i)  $2x + y = 5$  ,  $3x + 5y = -3$

ii)  $x + 2y - z = 3$  ,  $3x - y + 2z = 1$  and  $2x - 3y + 3z = 2$

iii)  $x - 3y + z = 2$  ,  $3x + y + z = 1$  and  $5x + y + 3z = 3$

20) The sum of three numbers is 6. If we multiply third number by 3 and add it the second number we get 11. By the adding first and third number we get a number which is double the second number. Use this information and find a system of linear equations. Find the three number using matrices.

**Activities**

1) Construct a matrix of order  $2 \times 2$  where the  $(ij)^{\text{th}}$  element given by  $a_{ij} = \frac{(i+j)^2}{2+i}$

**Solution:** Let  $A = \begin{bmatrix} a_{11} & a_{12} \\ a_{21} & a_{22} \end{bmatrix}_{2 \times 2}$  be the required matrix.

Given that  $a_{ij} = \frac{(i+j)^2}{2+i}$ ,  $a_{11} = \frac{(\dots)^2}{\dots+1} = \frac{4}{3}$ ,  $a_{12} = \frac{(\dots)^2}{\dots} = \frac{9}{3} = \dots$

$$a_{21} = \frac{(2+1)^2}{2+2} = \frac{\dots}{4}, \quad a_{22} = \frac{(\dots)^2}{2+2} = \frac{\dots}{\dots} = 4$$

$$\therefore A = \begin{bmatrix} \frac{4}{3} & \dots \\ \dots & 4 \end{bmatrix}$$

2) If  $A = \begin{bmatrix} 1 & -5 \\ 6 & 7 \end{bmatrix}$ ,  $B = \begin{bmatrix} 2 & -3 \\ 4 & 8 \end{bmatrix}$ , Find  $AB - 2I$ , where I is unit matrix of order 2.

**Solution:** Given  $A = \begin{bmatrix} 1 & -5 \\ 6 & 7 \end{bmatrix}$ ,  $B = \begin{bmatrix} 2 & -3 \\ 4 & 8 \end{bmatrix}$

Consider  $AB - 2I = \begin{bmatrix} 1 & -5 \\ 6 & 7 \end{bmatrix} \begin{bmatrix} 2 & -3 \\ 4 & 8 \end{bmatrix} - 2 \begin{bmatrix} \dots & \dots \\ \dots & \dots \end{bmatrix}$

$$\therefore AB - 2I = \begin{bmatrix} \dots & -3-40 \\ 12+28 & \dots \end{bmatrix} - \begin{bmatrix} \dots & 0 \\ 0 & \dots \end{bmatrix} = \begin{bmatrix} \dots & -43 \\ 40 & \dots \end{bmatrix} - \begin{bmatrix} \dots & 0 \\ 0 & \dots \end{bmatrix}$$

$$\therefore AB - 2I = \begin{bmatrix} \dots & -43 \\ 40 & \dots \end{bmatrix}$$

3) If  $A = \begin{bmatrix} 1 & -1 \\ 2 & 3 \end{bmatrix}$  then find  $A^{-1}$  by the adjoint method.

**Solution:** Given  $A = \begin{bmatrix} 1 & -1 \\ 2 & 3 \end{bmatrix}$

$$|A| = \begin{vmatrix} 1 & -1 \\ 2 & 3 \end{vmatrix} = \dots = \dots \neq 0$$

$\therefore A^{-1}$  is exist



$$\begin{aligned}
M_{11} &= \dots, & \therefore A_{11} &= (-1)^{1+1}M_{11} = \dots = \dots \\
M_{12} &= \dots, & \therefore A_{12} &= (-1)^{1+2}M_{12} = \dots = \dots \\
M_{21} &= \dots, & \therefore A_{21} &= (-1)^{2+1}M_{21} = \dots = \dots \\
M_{22} &= \dots, & \therefore A_{22} &= (-1)^{2+2}M_{22} = \dots = \dots
\end{aligned}$$

$$\begin{aligned}
\therefore [A_{ij}]_{2 \times 2} &= \begin{bmatrix} \dots & \dots \\ \dots & \dots \end{bmatrix} \\
\text{Adj}(A) &= [A_{ij}]^T = \begin{bmatrix} \dots & \dots \\ \dots & \dots \end{bmatrix} \\
A^{-1} &= \frac{1}{|A|} \text{Adj}(A) \\
A^{-1} &= \frac{1}{\dots} \begin{bmatrix} \dots & \dots \\ \dots & \dots \end{bmatrix}
\end{aligned}$$

4) Solve the following equations by inversion method.

$$x + 2y = 1$$

$$2x - 3y = 4$$

**Solution:**  $A = \begin{bmatrix} \dots & \dots \\ \dots & \dots \end{bmatrix}, X = \begin{bmatrix} x \\ y \end{bmatrix}, B = \begin{bmatrix} \dots \\ 4 \end{bmatrix},$

Given equations can be written as  $AX = B$

Pre-multiplying by  $A^{-1}$ , we get

$$A^{-1}(AX) = A^{-1}B$$

$$\dots = A^{-1}B$$

$$IX = A^{-1}B$$

$$X = A^{-1}B$$

First we find the inverse of A by row transformation

We write  $AA^{-1} = I$

$$\text{Using } R_2 \rightarrow R_2 - 2R_1 \quad \begin{bmatrix} 1 & 2 \\ 0 & \dots \end{bmatrix} A^{-1} = \begin{bmatrix} 1 & 0 \\ \dots & 1 \end{bmatrix}$$

$$\text{Using } \left(\frac{-1}{7}\right) R_2 \quad \begin{bmatrix} 1 & 2 \\ 0 & \dots \end{bmatrix} A^{-1} = \begin{bmatrix} 1 & 0 \\ \dots & -1 \\ \dots & \dots \end{bmatrix}$$

$$\text{Using } R_1 \rightarrow R_1 - 2R_2 \quad \begin{bmatrix} 1 & 0 \\ 0 & 1 \end{bmatrix} A^{-1} = \begin{bmatrix} \dots & \dots \\ \dots & \dots \\ \dots & -1 \\ \dots & \dots \end{bmatrix}$$

$$A^{-1} = \frac{1}{\dots} \begin{bmatrix} 1 & \frac{3}{2} \\ 3 & -1 \end{bmatrix}$$

$$\begin{aligned} X = A^{-1}B &= \frac{1}{\dots} \begin{bmatrix} \dots & \dots \\ \dots & \dots \end{bmatrix} \begin{bmatrix} 1 \\ 4 \end{bmatrix} \\ &= \frac{1}{\dots} \begin{bmatrix} \dots & \dots \\ \dots & \dots \end{bmatrix} = \frac{1}{\dots} \begin{bmatrix} \dots & \dots \\ \dots & \dots \end{bmatrix} = \begin{bmatrix} \dots & \dots \\ \dots & \dots \end{bmatrix} \\ &\begin{bmatrix} x \\ y \end{bmatrix} = \begin{bmatrix} \dots \\ \dots \end{bmatrix} \end{aligned}$$

$$\therefore x = \frac{11}{7}, y = \frac{-2}{7}$$

Hence the solution of given linear equation is  $x = \frac{11}{7}, y = \frac{-2}{7}$

5) Express the following equations in matrix form and solve them by the method of reduction

$$x + 3y + 3z = 12, x + 4y + 4z = 15, \quad x + 3y + 4z = 13.$$

**Solution:** The given equations can be write as

$$x + 3y + 3z = 12, x + 4y + 4z = 15, \quad x + 3y + 4z = 13.$$

Hence the matrix equation is  $AX = B$

$$\begin{bmatrix} \dots & \dots & \dots \\ \dots & \dots & \dots \\ \dots & \dots & \dots \end{bmatrix} \begin{bmatrix} x \\ y \\ z \end{bmatrix} = \begin{bmatrix} \dots \\ \dots \\ \dots \end{bmatrix} \quad (\text{i.e. } AX = B)$$

$$\text{By } R_2 \rightarrow R_2 - R_1 \text{ and } R_3 \rightarrow R_3 - R_1 \quad \begin{bmatrix} 1 & 3 & 3 \\ \dots & \dots & \dots \\ \dots & \dots & \dots \end{bmatrix} \begin{bmatrix} x \\ y \\ z \end{bmatrix} = \begin{bmatrix} 12 \\ \dots \\ \dots \end{bmatrix}$$

We write equation as

$$x + 3y + 3z = 12 \text{ ----- (1)}$$

$$y + z = \dots \text{ ----- (2)}$$

$$z = \dots \text{ ----- (3)}$$

from (3),  $z=1$

Put  $z = 1$  in equation (2)  $y + \dots = \dots$   $y = \dots$

Put  $y = \dots, z = 1$  in equation (1)  $x + \dots + \dots = \dots, x = \dots$

$\therefore x = \dots, y = \dots, z = 1$



**Let's Study**

1. Derivatives of composite functions.
2. Derivatives of inverse functions.
3. Derivatives of logarithmic functions.
4. Derivatives of implicit function.
5. Derivatives of parametric functions.
6. Derivative of second order.

**Let's Recall**

1. Concept of continuity
2. Concept of Differentiability.
3. Derivatives of some standard functions.

	$y = f(x)$	$\frac{dy}{dx} = f'(x)$
1	K(constant)	0
2	$x$	1
3	$\sqrt{x}$	$\frac{1}{2\sqrt{x}}$
4	$\frac{1}{x}$	$-\frac{1}{x^2}$
5	$x^n$	$n \cdot x^{n-1}$
6	$a^x$	$a^x \cdot \log a$
7	$e^x$	$e^x$
8	$\log x$	$\frac{1}{x}$

**4. Rules of Differentiation:**

If  $u$  and  $v$  are differentiable functions of  $x$  and if

$$1. \quad y = u + v \text{ then } \frac{dy}{dx} = \frac{du}{dx} + \frac{dv}{dx}$$

$$2. \quad y = u - v \text{ then } \frac{dy}{dx} = \frac{du}{dx} - \frac{dv}{dx}$$

$$3. \quad y = u \cdot v \text{ then } \frac{dy}{dx} = u \frac{dv}{dx} + v \frac{du}{dx}$$

$$4. \quad y = \frac{u}{v} \text{ then } \frac{dy}{dx} = \frac{v \frac{du}{dx} - u \frac{dv}{dx}}{v^2}, \quad v \neq 0$$

$$5. \quad y = k \cdot u \text{ then } \frac{dy}{dx} = k \cdot \frac{du}{dx}, \quad k \text{ constant.}$$

**Introduction:**

In Standard XI, we have studied the concept of differentiation. We have used this concept in calculating marginal demand and marginal cost of a commodity.

**Let's Learn****3.1 Derivative of a Composite Function:**

Sometimes complex looking functions can be greatly simplified by expressing them as compositions of two or more different functions. It is then not possible to differentiate them directly is possible with simple functions.

Now, we discuss differentiation of such composite functions using the chain rule.

**Result 1:** If  $y = f(u)$  is a differentiable function of  $u$  and  $u = g(x)$  is a differentiable function of  $x$  then

$$\frac{dy}{dx} = \frac{dy}{du} \times \frac{du}{dx}$$

(This is called Chain Rule)

### Generalisation:

If  $y$  is a differentiable function of  $u_1$ ,  $u_i$  is a differentiable function of  $u_{i+1}$ , for  $i = 1, 2, 3, \dots, (n-1)$  and  $u_n$  is a differentiable function of  $x$  then

$$\frac{dy}{dx} = \frac{dy}{du_1} \times \frac{du_1}{du_2} \times \frac{du_2}{du_3} \times \dots \times \frac{du_n}{dx}$$

### SOLVED EXAMPLES

1)  $y = (4x^3 + 3x^2 - 2x)^6$ . Find  $\frac{dy}{dx}$

**Solution:** Given  $y = (4x^3 + 3x^2 - 2x)^6$

Let  $u = (4x^3 + 3x^2 - 2x)$

$$\therefore y = u^6$$

$$\therefore \frac{dy}{du} = 6u^5$$

$$\therefore \frac{dy}{dx} = 6(4x^3 + 3x^2 - 2x)^5$$

and  $\frac{du}{dx} = 12x^2 + 6x - 2$

By chain Rule  $\frac{dy}{dx} = \frac{dy}{du} \times \frac{du}{dx}$

$$\therefore \frac{dy}{dx} = 6(4x^3 + 3x^2 - 2x)^5(12x^2 + 6x - 2)$$

2)  $y = \log(4x^2 + 3x - 1)$ . Find  $\frac{dy}{dx}$

**Solution:** Given  $y = \log(4x^2 + 3x - 1)$

Let  $u = (4x^2 + 3x - 1)$

$$\therefore y = \log(u)$$

$$\therefore \frac{dy}{du} = \frac{1}{u}$$

$$\therefore \frac{dy}{dx} = \frac{1}{(4x^2 + 3x - 1)}$$

and  $\frac{du}{dx} = (8x + 3)$

By chain Rule  $\frac{dy}{dx} = \frac{dy}{du} \times \frac{du}{dx}$

$$\therefore \frac{dy}{du} = \frac{1}{(4x^2 + 3x - 1)} (8x + 3)$$

$$\therefore \frac{dy}{dx} = \frac{8x + 3}{(4x^2 + 3x - 1)}$$

3) If  $y = \sqrt[3]{(3x^2 + 8x - 7)^5}$ , find  $\frac{dy}{dx}$

**Solution:** Given  $y = \sqrt[3]{(3x^2 + 8x - 7)^5}$

$$\therefore y = (3x^2 + 8x - 7)^{\frac{5}{3}}$$

Let  $u = (3x^2 + 8x - 7)$

$$\therefore y = u^{\frac{5}{3}}$$

$$\therefore \frac{dy}{du} = \frac{5}{3}u^{\frac{2}{3}}$$

$$\therefore \frac{dy}{dx} = \frac{5}{3}(3x^2 + 8x - 7)^{\frac{2}{3}}$$

and  $\frac{du}{dx} = (6x + 8)$

By chain Rule  $\frac{dy}{dx} = \frac{dy}{du} \times \frac{du}{dx}$

$$\therefore \frac{dy}{dx} = \frac{5}{3}(3x^2 + 8x - 7)^{\frac{2}{3}} (6x + 8)$$

4) If  $y = e^{(\log x + 6)}$ , find  $\frac{dy}{dx}$

**Solution:** Given  $y = e^{(\log x + 6)}$

Let  $u = \log x + 6$

$$\therefore y = e^u$$

$$\therefore \frac{dy}{du} = e^u$$

$$\therefore \frac{dy}{dx} = e^{(\log x + 6)} \quad \text{and} \quad \frac{du}{dx} = \frac{1}{x}$$

By chain Rule  $\frac{dy}{dx} = \frac{dy}{du} \times \frac{du}{dx}$

$$\therefore \frac{dy}{dx} = e^{(\log x + 6)} \frac{1}{x}$$

### EXERCISE 3.1

**Q.1 Find  $\frac{dy}{dx}$  if,**

1)  $y = \sqrt{x + \frac{1}{x}}$

2)  $y = \sqrt[3]{a^2 + x^2}$

3)  $y = (5x^3 - 4x^2 - 8x)^9$

**Q.2 Find  $\frac{dy}{dx}$  if,**

1)  $y = \log(\log x)$

2)  $y = \log(10x^4 + 5x^3 - 3x^2 + 2)$

3)  $y = \log(ax^2 + bx + c)$

**Q.3 Find  $\frac{dy}{dx}$  if,**

1)  $y = e^{5x^2 - 2x + 4}$

2)  $y = a^{(1 + \log x)}$

3)  $y = 5^{(x + \log x)}$

### 3.2 Derivative of an Inverse Function:

Let  $y = f(x)$  be a real valued function defined on an appropriate domain. The inverse of this function exists if and only if the function is one-one and onto.

**For example:** Let  $f : \mathbb{R} \rightarrow \mathbb{R}$  be such that  $f(x) = x + 10$  then inverse of  $f$  is

$$f^{-1} : \mathbb{R} \rightarrow \mathbb{R} \text{ such that } f^{-1}(y) = y - 10$$

That is, if  $y = x + 10$  then  $x = y - 10$

**Result 2 :** If  $y = f(x)$  is a differentiable function of  $x$  such that inverse function  $x = f^{-1}(y)$  exists, then  $x$  is a differentiable function of  $y$

$$\text{and } \frac{dx}{dy} = \frac{1}{\frac{dy}{dx}}, \quad \frac{dy}{dx} \neq 0$$

### SOLVED EXAMPLES

1) Find rate of change of demand ( $x$ ) of a commodity with respect to its price ( $y$ ) if

$$y = 20 + 15x + x^2$$

**Solution:** Let  $y = 20 + 15x + x^2$

Differentiating both sides with respect to  $x$ , we get

$$\therefore \frac{dy}{dx} = 15 + 2x$$

By derivative of the inverse function

$$\therefore \frac{dx}{dy} = \frac{1}{\frac{dy}{dx}}, \quad \frac{dy}{dx} \neq 0$$

$\therefore$  rate of change of demand with respect

$$\text{to price} = \frac{dx}{dy} = \frac{1}{15 + 2x}$$

2) Find rate of change of demand ( $x$ ) of a commodity with respect to its price ( $y$ ) if

$$y = 5 + x^2e^{-x} + 2x$$

**Solution:** Let  $y = 5 + x^2e^{-x} + 2x$

Differentiating both sides with respect to  $x$ , we get

$$\therefore \frac{dy}{dx} = (-x^2e^{-x} + 2xe^{-x} + 2)$$

By derivative of the inverse function

$$\therefore \frac{dx}{dy} = \frac{1}{\frac{dy}{dx}}, \quad \frac{dy}{dx} \neq 0$$

$\therefore$  Rate of change of demand with respect

$$\text{to price} = \frac{dx}{dy} = \frac{1}{(-x^2e^{-x} + 2xe^{-x} + 2)}$$

3) Find rate of change of demand ( $x$ ) of a commodity with respect to its price ( $y$ ) if

$$y = \frac{3x + 7}{2x^2 + 5}$$

**Solution:** Let  $y = \frac{3x + 7}{2x^2 + 5}$

Differentiating both sides with respect to  $x$ , we get

$$\therefore \frac{dy}{dx} = \frac{(2x^2 + 5)(3) - (3x + 7)(4x)}{(2x^2 + 5)^2}$$

$$\therefore \frac{dy}{dx} = \frac{(6x^2 + 15) - (12x^2 + 28x)}{(2x^2 + 5)^2}$$

$$\therefore \frac{dy}{dx} = \frac{(6x^2 + 15 - 12x^2 - 28x)}{(2x^2 + 5)^2}$$

$$\therefore \frac{dy}{dx} = \frac{(-6x^2 - 28x + 15)}{(2x^2 + 5)^2}$$

By derivative of the inverse function

$$\therefore \frac{dx}{dy} = \frac{1}{\frac{dy}{dx}}, \quad \frac{dy}{dx} \neq 0$$

$\therefore$  Rate of change of demand with respect to

$$\text{price} = \frac{dx}{dy} = \frac{(2x^2 + 5)^2}{(-6x^2 - 28x + 15)}$$

### EXERCISE 3.2

**Q.1 Find the rate of change of demand ( $x$ ) of a commodity with respect to its price ( $y$ ) if**

1)  $y = 12 + 10x + 25x^2$

2)  $y = 18x + \log(x - 4)$

3)  $y = 25x + \log(1 + x^2)$

**Q.2 Find the marginal demand of a commodity where demand is  $x$  and price is  $y$**

1)  $y = xe^{-x} + 7$

2)  $y = \frac{x+2}{x^2+1}$

3)  $y = \frac{5x+9}{2x-10}$

### 3.3 Derivative of a Logarithmic Function:

Sometimes we have to differentiate a function involving complicated expressions

like  $f(x) \cdot g(x)$ ,  $\frac{f(x)}{g(x)}$  and  $[f(x)]^{g(x)}$ . In this case, we first transform the expression to a logarithmic form and then find its derivative. Hence the method is called logarithmic differentiation. That is,

$$\frac{d(\log y)}{dx} = \frac{1}{y} \frac{dy}{dx}$$

Examples of Logarithmic Functions.

1)  $y = \frac{(6x+5)^5}{(3x^2-1)\sqrt{8+2x}}$

2)  $y = (e^x + 1)^x \times (x + 1)^{(x+2)}$

**Note :** 1) The log function to the base "e" is called Natural log and the log function to the base 10 is called common log.

2) In  $(a)^{b^c}$ ,  $a$  is the base and  $b^c$  is the index.

**Some Basic Laws of logarithms:**

1)  $\log_a m n = \log_a m + \log_a n$

2)  $\log_a \frac{m}{n} = \log_a m - \log_a n$

3)  $\log_a m^n = n \log_a m$

4)  $\log_n m = \frac{\log_a m}{\log_a n}$

5)  $\log_e = 1 (= \log_a a)$

6)  $\log_a a^x = x$

### SOLVED EXAMPLES

1) Find  $\frac{dy}{dx}$ , if  $y = (3 + x)^x$

**Solution:** let  $y = (3 + x)^x$

Taking logarithm of both sides, we get

$$\therefore \log y = \log(3 + x)^x$$

$$\therefore \log y = x \log(3 + x)$$

Differentiating both sides with respect to  $x$ , we get

$$\therefore \frac{1}{y} \frac{dy}{dx} = x \left( \frac{1}{3+x} \right) + \log(3+x) \times 1$$

$$\therefore \frac{dy}{dx} = y \left[ x \left( \frac{1}{3+x} \right) + \log(3+x) \right]$$

$$\therefore \frac{dy}{dx} = (3+x)^x \left[ \frac{x}{3+x} + \log(3+x) \right]$$

2) Find  $\frac{dy}{dx}$ , if  $y = x^{x^x}$

**Solution:** Let  $y = x^{x^x}$

Taking logarithm of both sides, we get

$$\therefore \log y = \log x^{x^x}$$

$$\therefore \log y = x^x \log(x)$$

Differentiating both sides with respect to  $x$ , we get

$$\therefore \frac{1}{y} \frac{dy}{dx} = x^x \frac{1}{x} + \log(x) \cdot \frac{dx^x}{dx}$$

$$\therefore \frac{dy}{dx} = y \left[ x^x \frac{1}{x} + \log(x) \cdot \frac{dx^x}{dx} \right] \dots\dots\dots \text{(I)}$$

Let  $u = x^x$

Taking logarithm of both sides, we get

$$\therefore \log u = x \cdot \log(x)$$

Differentiating both sides with respect to  $x$ , we get

$$\therefore \frac{1}{u} \frac{du}{dx} = x \cdot \frac{1}{x} + \log(x) \cdot 1$$

$$\therefore \frac{du}{dx} = u [1 + \log x]$$

$$\therefore \frac{du}{dx} = x^x (1 + \log x) \dots\dots\dots \text{(II)}$$

Substituting eq<sup>n</sup> (II) in eq<sup>n</sup> (I), we get

$$\therefore \frac{dy}{dx} = y \left[ x^x \frac{1}{x} + \log(x) \cdot x^x (1 + \log x) \right]$$

$$\therefore \frac{dy}{dx} = x^{x^x} \cdot x^x \left[ \frac{1}{x} + \log(x) \cdot (1 + \log x) \right]$$

3) Find  $\frac{dy}{dx}$ , if  $y = \sqrt{\frac{(2x+3)^5}{(3x-1)^3(5x-2)}}$

**Solution:** Let  $y = \sqrt{\frac{(2x+3)^5}{(3x-1)^3(5x-2)}}$

$$y = \left( \frac{(2x+3)^5}{(3x-1)^3(5x-2)} \right)^{\frac{1}{2}}$$

Taking logarithm of both sides, we get

$$\therefore \log y = \frac{1}{2} \left\{ \log \left( \frac{(2x+3)^5}{(3x-1)^3(5x-2)} \right) \right\}$$

$$\therefore \log y = \frac{1}{2} [5\log(2x+3) - 3\log(3x-1) - \log(5x-2)]$$

Differentiating both sides with respect to  $x$ , we get

$$\therefore \frac{1}{y} \frac{dy}{dx} = \frac{1}{2} \left[ 5 \frac{2}{(2x+3)} - 3 \frac{3}{(3x-1)} - \frac{5}{(5x-2)} \right]$$

$$\therefore \frac{dy}{dx} = \frac{1}{2} y \left[ \frac{10}{(2x+3)} - \frac{9}{(3x-1)} - \frac{5}{(5x-2)} \right]$$

$$\therefore \frac{dy}{dx} = \frac{1}{2} \sqrt{\frac{(2x+3)^5}{(2x-1)^3(5x-2)}} \left[ \frac{10}{(2x+3)} - \frac{9}{(3x-1)} - \frac{5}{(5x-2)} \right]$$

4) Find  $\frac{dy}{dx}$ , if  $y = x^x + (\log x)^x$

**Solution:** Let  $y = x^x + (\log x)^x$

Let  $u = x^x$  and  $v = (\log x)^x$

$$\therefore y = u + v$$

Differentiating both sides with respect to  $x$ , we get

$$\frac{dy}{dx} = \frac{du}{dx} + \frac{dv}{dx}$$

Now,  $u = x^x$

Taking logarithm of both sides, we get

$$\therefore \log u = x \log x$$

Differentiating both sides with respect to  $x$ , we get,

$$\therefore \frac{1}{u} \frac{du}{dx} = x \frac{1}{x} + \log x.1$$

$$\therefore \frac{du}{dx} = u(1 + \log x)$$

$$\therefore \frac{du}{dx} = x^x(1 + \log x) \dots \dots \dots \text{(II)}$$

$$\text{Now, } v = (\log x)^x$$

Taking logarithm of both sides, we get

$$\therefore \log v = x \log(\log x)$$

Differentiating both sides with respect to  $x$ , we get,

$$\therefore \frac{1}{v} \frac{dv}{dx} = x \frac{1}{x \cdot \log x} + \log(\log x).1$$

$$\therefore \frac{dv}{dx} = v \left[ \frac{1}{\log x} + \log(\log x) \right]$$

$$\therefore \frac{dv}{dx} = (\log x)^x \left[ \frac{1}{\log x} + \log(\log x) \right] \dots \dots \text{(III)}$$

Substituting eq<sup>n</sup> (II) and eq<sup>n</sup> (III) in eq<sup>n</sup> (I), we get

$$\therefore \frac{dy}{dx} = x^x(1 + \log x) + (\log x)^x \left[ \frac{1}{\log x} + \log(\log x) \right]$$

**EXERCISE 3.3**

**Q.1 Find  $\frac{dy}{dx}$  if,**

- 1)  $y = x^{x^{2x}}$
- 2)  $y = x^{e^x}$
- 3)  $y = e^{x^x}$

**Q.2 Find  $\frac{dy}{dx}$  if,**

- 1)  $y = \left(1 + \frac{1}{x}\right)^x$
- 2)  $y = (2x + 5)^x$

$$3) y = \sqrt[3]{\frac{(3x-1)}{(2x+3)(5-x)^2}}$$

**Q.3 Find  $\frac{dy}{dx}$  if,**

- 1)  $y = (\log x)^x + x^{\log x}$
- 2)  $y = (x)^x + (a)^x$
- 3)  $y = 10^{x^x} + 10^{x^{10}} + 10^{10^x}$

**3.4 Derivative of an Implicit Function:**

If the variable  $y$  can be expressed as a function of the variable  $x$ . that is,  $y = f(x)$  then the function  $f(x)$  is called an explicit function of  $x$ .

**For Example:**  $f(x) = x^2 + x^{-3}$ ,  $y = \log x + e$

If it is not possible to express  $y$  as a function of  $x$  or  $x$  as a function of  $y$  then the function is called an implicit function.

**For Example:**  $ax^2 + 2hxy + by^2 = 0$  ;  
 $x^m + y^n = (x + y)^{m+n}$

The general form of an implicit function of two variables  $x$  and  $y$  is  $f(x,y)=0$

**Solved Examples:**

1) Find  $\frac{dy}{dx}$  if  $y^3 - 3y^2x = x^3 + 3x^2y$

**Solution:** Given  $y^3 - 3y^2x = x^3 + 3x^2y$

Differentiating both sides with respect to  $x$ , we get

$$\begin{aligned} \therefore 3y^2 \frac{dy}{dx} - 3y^2 - 3x(2y) \frac{dy}{dx} \\ = 3x^2 + 3x^2 \frac{dy}{dx} + 3y(2x) \end{aligned}$$

$$\begin{aligned} \therefore 3y^2 \frac{dy}{dx} - 6xy \frac{dy}{dx} - 3x^2 \frac{dy}{dx} \\ = 3x^2 + 6xy + 3y^2 \end{aligned}$$

$$\therefore (3y^2 - 6xy - 3x^2) \frac{dy}{dx} = (3x^2 + 6xy + 3y^2)$$

$$\therefore (y^2 - 2xy - x^2) \frac{dy}{dx} = (x^2 + 2xy + y^2)$$



$$\therefore \frac{dy}{dx} = \frac{(x^2 + 2xy + y^2)}{(y^2 - 2xy - x^2)}$$

2) Find  $\frac{dy}{dx}$  if  $x^y = y^x$

**Solution:** Given  $x^y = y^x$

Taking logarithm of both sides, we get

$$\therefore y \log x = x \log y$$

Differentiating both sides with respect to  $x$ , we get

$$\therefore y \frac{1}{x} + \log x \frac{dy}{dx} = x \frac{1}{y} \frac{dy}{dx} + \log y \cdot 1$$

$$\therefore \log x \frac{dy}{dx} - \frac{x}{y} \frac{dy}{dx} = \log y - \frac{y}{x}$$

$$\therefore \left( \log x - \frac{x}{y} \right) \frac{dy}{dx} = \left( \log y - \frac{y}{x} \right)$$

$$\therefore \left( \frac{y \cdot \log x - x}{y} \right) \frac{dy}{dx} = \left( \frac{x \cdot \log y - y}{x} \right)$$

$$\therefore \frac{dy}{dx} = \left( \frac{x \cdot \log y - y}{x} \right) \left( \frac{y}{y \cdot \log x - x} \right)$$

$$\therefore \frac{dy}{dx} = \frac{y}{x} \left( \frac{x \cdot \log y - y}{y \cdot \log x - x} \right)$$

3) If  $x^m \cdot y^n = (x + y)^{(m+n)}$  then show that,

$$\frac{dy}{dx} = \frac{y}{x}$$

**Solution:** Given  $x^m \cdot y^n = (x + y)^{(m+n)}$

Taking logarithm of both sides, we get

$$\therefore m \cdot \log x + n \cdot \log y = (m + n) \log(x + y)$$

Differentiating both sides with respect to  $x$ , we get

$$\therefore m \frac{1}{x} + n \frac{1}{y} \frac{dy}{dx} = (m + n) \frac{1}{x + y} \left( 1 + \frac{dy}{dx} \right)$$

$$\therefore \frac{m}{x} + \frac{n}{y} \frac{dy}{dx} = \frac{(m + n)}{(x + y)} \left( 1 + \frac{dy}{dx} \right)$$

$$\therefore \frac{n}{y} \frac{dy}{dx} - \frac{(m + n)}{(x + y)} \frac{dy}{dx} = \frac{(m + n)}{(x + y)} - \frac{m}{x}$$

$$\therefore \left( \frac{n}{y} - \frac{(m + n)}{(x + y)} \right) \frac{dy}{dx} = \left( \frac{(m + n)}{(x + y)} - \frac{m}{x} \right)$$

$$\therefore \left[ \frac{nx + ny - my - ny}{y(x + y)} \right] \frac{dy}{dx} = \left[ \frac{mx + nx - mx - my}{x(x + y)} \right]$$

$$\therefore \left[ \frac{nx - my}{y} \right] \frac{dy}{dx} = \left[ \frac{nx - my}{x} \right]$$

$$\therefore \frac{dy}{dx} = \left[ \frac{nx - my}{x} \right] \left[ \frac{y}{nx - my} \right]$$

$$\therefore \frac{dy}{dx} = \frac{y}{x}$$

### EXERCISE 3.4

**Q.1 Find  $\frac{dy}{dx}$  if,**

- 1)  $\sqrt{x} + \sqrt{y} = \sqrt{a}$
- 2)  $x^3 + y^3 + 4x^3y = 0$
- 3)  $x^3 + x^2y + xy^2 + y^3 = 81$

**Q.2 Find  $\frac{dy}{dx}$  if,**

- 1)  $y \cdot e^x + x \cdot e^y = 1$
- 2)  $x^y = e^{(x-y)}$
- 3)  $xy = \log(xy)$

**Q.3 Solve the following.**

1) If  $x^5 \cdot y^7 = (x + y)^{12}$  then show that,

$$\frac{dy}{dx} = \frac{y}{x}$$

2) If  $\log(x+y) = \log(xy) + a$  then show

$$\text{that, } \frac{dy}{dx} = \frac{-y^2}{x^2}$$

3) If  $e^x + e^y = e^{(x+y)}$  then show that,

$$\frac{dy}{dx} = -e^{y-x}$$

### 3.5 Derivative of a Parametric Function:

Now we consider  $y$  as a function of  $x$  where both  $x$  and  $y$  are functions of a variable ' $t$ '. Here ' $t$ ' is called a parameter.

**Result 3:** If  $x = f(t)$  and  $y = g(t)$  are differentiable functions of a parameter ' $t$ ', then  $y$  is a differential function of  $x$  and

$$\frac{dy}{dx} = \frac{\frac{dy}{dt}}{\frac{dx}{dt}}, \frac{dx}{dt} \neq 0$$

#### SOLVED EXAMPLES

1) Find  $\frac{dy}{dx}$ , if  $x = 2at, y = 2at^2$

**Solution:** Given  $x = 2at, y = 2at^2$

Now,  $y = 2at^2$

Differentiate with respect to  $t$

$$\therefore \frac{dy}{dt} = 2a \cdot 2t = 4at \quad \dots\dots\dots \text{(I)}$$

$x = 2at$

Differentiate with respect to  $t$

$$\therefore \frac{dx}{dt} = 2a \quad \dots\dots\dots \text{(II)}$$

Now,  $\frac{dy}{dx} = \frac{\frac{dy}{dt}}{\frac{dx}{dt}}$

$$\therefore \frac{dy}{dx} = \frac{4at}{2a}$$

$$\therefore \frac{dy}{dx} = 2t$$

2) Find  $\frac{dy}{dx}$ , if  $x = e^{2t}, y = e^{\sqrt{t}}$

**Solution:** Given  $x = e^{2t}, y = e^{\sqrt{t}}$

Now,  $y = e^{\sqrt{t}}$

Differentiate  $y$  with respect to  $t$

$$\therefore \frac{dy}{dt} = e^{\sqrt{t}} \frac{d}{dt} \sqrt{t} \quad \dots\dots\dots \text{(I)}$$

Differentiate with respect to  $t$

$$\therefore \frac{dx}{dt} = 2e^{2t} \quad \dots\dots\dots \text{(II)}$$

Now,  $\frac{dy}{dx} = \frac{\frac{dy}{dt}}{\frac{dx}{dt}}$

$$\therefore \frac{dy}{dx} = \frac{e^{\sqrt{t}} \frac{1}{2\sqrt{t}}}{2e^{2t}}$$

$$\therefore \frac{dy}{dx} = \frac{e^{\sqrt{t}}}{4\sqrt{t} e^{2t}}$$

3) Differentiate  $\log(t)$  with respect to  $\log(1+t^2)$

**Solution:** let  $y = \log(t)$  and  $x = \log(1+t^2)$

Now,  $y = \log(t)$

Differentiate with respect to  $t$

$$\therefore \frac{dy}{dt} = \frac{1}{t} \quad \dots\dots\dots \text{(I)}$$

Now,  $x = \log(1+t^2)$

Differentiate with respect to  $t$

$$\therefore \frac{dx}{dt} = \frac{2t}{1+t^2} \quad \dots\dots\dots \text{(II)}$$

Now,  $\frac{dy}{dx} = \frac{\frac{dy}{dt}}{\frac{dx}{dt}}$

$$\therefore \frac{dy}{dx} = \frac{\frac{1}{t}}{\frac{2t}{1+t^2}}$$

$$\therefore \frac{dy}{dx} = \frac{1+t^2}{2t^2}$$

### EXERCISE 3.5

**Q.1 Find**  $\frac{dy}{dx}$  **if,**

- 1)  $x = at^2, y = 2at$
- 2)  $x = 2at^2, y = at^4$
- 3)  $x = e^{3t}, y = e^{(4t+5)}$

**Q.2 Find**  $\frac{dy}{dx}$  **if,**

- 1)  $x = \left(u + \frac{1}{u}\right)^2, y = (2)^{\left(u + \frac{1}{u}\right)}$
- 2)  $x = \sqrt{1+u^2}, y = \log(1+u^2)$
- 3) Differentiate  $5^x$  with respect to  $\log x$

**Q.3 Solve the following.**

1) If  $x = a\left(1 - \frac{1}{t}\right), y = a\left(1 + \frac{1}{t}\right)$  then,

show that  $\frac{dy}{dx} = -1$

2) If  $x = \frac{4t}{1+t^2}, y = 3\left(\frac{1-t^2}{1+t^2}\right)$  then,

show that  $\frac{dy}{dx} = \frac{-9x}{4y}$

3) If  $x = t \cdot \log t, y = t^t$  then, show that

$$\frac{dy}{dx} - y = 0$$

### 3.6 Second Order Derivative:

Consider a differentiable function  $y = f(x)$   
 then  $\frac{dy}{dx} = f'(x)$  is the first order derivative of  $y$  with respect to  $x$ . It is also denoted by  $y'$  or  $y_1$

If  $f'(x)$  is a differentiable function of  $x$

then  $d\left(\frac{dy}{dx}\right)$  denoted by  $\frac{d^2y}{dx^2}$  or  $f''(x)$  is called

the second order derivative of  $y$  with respect to  $x$ . It is also denoted by  $y''$  or  $y_2$

If  $f''(x)$  is a differential function of  $x$

then  $d\left(\frac{d^2y}{dx^2}\right)$  denoted by  $\frac{d^3y}{dx^3}$  or  $f'''(x)$  is

called the third order derivative of  $y$  with respect to  $x$ . It is also denoted by  $y'''$  or  $y_3$ .

### SOLVED EXAMPLES

1) Find  $\frac{d^2y}{dx^2}$ , if  $y = x^2$

**Solution:** Given  $y = x^2$

Differentiate with respect to  $x$

$$\therefore \frac{dy}{dx} = 2x$$

Differentiate with respect to  $x$ , again

$$\therefore \frac{d^2y}{dx^2} = 2$$

2) Find  $\frac{d^2y}{dx^2}$ , if  $y = x^6$

**Solution:** Given  $y = x^6$

Differentiate with respect to  $x$

$$\therefore \frac{dy}{dx} = 6x^5$$

Differentiate with respect to  $x$ , again

$$\therefore \frac{d^2y}{dx^2} = 6(5x^4)$$

$$\therefore \frac{d^2y}{dx^2} = 30x^4$$

3) Find  $\frac{d^2y}{dx^2}$ , if  $y = \log x$

**Solution:** Given  $y = \log x$

Differentiate with respect to  $x$

$$\therefore \frac{dy}{dx} = \frac{1}{x}$$

Differentiate with respect to  $x$ , again

$$\therefore \frac{d^2y}{dx^2} = \frac{-1}{x^2}$$

4) Find  $\frac{d^2y}{dx^2}$ , if  $y = e^{4x}$

**Solution:** Given  $y = e^{4x}$

Differentiate with respect to  $x$

$$\therefore \frac{dy}{dx} = 4e^{4x}$$

$$\therefore \frac{d^2y}{dx^2} = 4(4e^{4x})$$

$$\therefore \frac{d^2y}{dx^2} = 16e^{4x}$$

### EXERCISE 3.6

**Q.1** Find  $\frac{d^2y}{dx^2}$  if,

1)  $y = \sqrt{x}$

2)  $y = x^5$

3)  $y = x^{-7}$

**Q.2** Find  $\frac{d^2y}{dx^2}$  if,

1)  $y = e^x$

2)  $y = e^{(2x+1)}$

3)  $y = e^{\log x}$



### Let's Remember

#### Derivative of some standard functions.

	$y = f(x)$	$\frac{dy}{dx} = f'(x)$
1	K (constant)	0
2	$x$	1
3	$\sqrt{x}$	$\frac{1}{2\sqrt{x}}$
4	$\frac{1}{x}$	$-\frac{1}{x^2}$
5	$x^n$	$n \cdot x^{n-1}$
6	$a^x$	$a^x \cdot \log a$
7	$e^x$	$e^x$
8	$\log x$	$\frac{1}{x}$

### Rules of Differentiation:

If  $u$  and  $v$  differentiable function of  $x$  and if

1.  $y = u + v$  then  $\frac{dy}{dx} = \frac{du}{dx} + \frac{dv}{dx}$

2.  $y = u - v$  then  $\frac{dy}{dx} = \frac{du}{dx} - \frac{dv}{dx}$

3.  $y = u \cdot v$  then  $\frac{dy}{dx} = u \frac{dv}{dx} + v \frac{du}{dx}$

4.  $y = \frac{u}{v}$  then  $\frac{dy}{dx} = \frac{v \frac{du}{dx} - u \frac{dv}{dx}}{v^2}$ ,  $v \neq 0$

### Derivative of a Composite Function:

If  $y = f(u)$  is a differentiable function of  $u$  and  $u = g(x)$  is a differentiable function of  $x$  then

$$\frac{dy}{dx} = \frac{dy}{du} \times \frac{du}{dx}$$

### Derivative of an Inverse Function :

If  $y = f(x)$  is a differentiable function of  $x$  such that the inverse function  $x = f^{-1}(y)$  exists, then  $x$  is a differentiable function of  $y$  and

$$\frac{dx}{dy} = \frac{1}{\frac{dy}{dx}}, \quad \frac{dy}{dx} \neq 0$$

### Derivative of a Parametric Function:

If  $x = f(t)$  and  $y = g(t)$  are differential functions of parameter ' $t$ ' then  $y$  is a differential function of  $x$  and

$$\frac{dy}{dx} = \frac{\frac{dy}{dt}}{\frac{dx}{dt}}$$

$$\frac{dx}{dt} \neq 0$$

### MISCELLANEOUS EXERCISE - 3

#### Q.I] Choose the correct alternative.

1) If  $y = (5x^3 - 4x^2 - 8x)^9$  then  $\frac{dy}{dx} = \text{-----}$

- a)  $9(5x^3 - 4x^2 - 8x)^8 (15x^2 - 8x - 8)$   
 b)  $9(5x^3 - 4x^2 - 8x)^9 (15x^2 - 8x - 8)$   
 c)  $9(5x^3 - 4x^2 - 8x)^8 (5x^2 - 8x - 8)$   
 d)  $9(5x^3 - 4x^2 - 8x)^9 (5x^2 - 8x - 8)$

2) If  $y = \sqrt{x + \frac{1}{x}}$  then  $\frac{dy}{dx} = ?$

- a)  $\frac{x^2 - 1}{2x^2\sqrt{x^2 + 1}}$       b)  $\frac{1 - x^2}{2x^2\sqrt{x^2 + 1}}$   
 c)  $\frac{x^2 - 1}{2x\sqrt{x}\sqrt{x^2 + 1}}$       d)  $\frac{1 - x^2}{2x\sqrt{x}\sqrt{x^2 + 1}}$

3) If  $y = e^{\log x}$  then  $\frac{dy}{dx} = ?$

- a)  $\frac{e^{\log x}}{x}$     b)  $\frac{1}{x}$     c) 0    d)  $\frac{1}{2}$

4) If  $y = 2x^2 + 2^2 + a^2$  then  $\frac{dy}{dx} = ?$

- a)  $x$     b)  $4x$     c)  $2x$     d)  $-2x$

5) If  $y = 5^x \cdot x^5$  then  $\frac{dy}{dx} = ?$

- a)  $5^x \cdot x^4 (5 + \log 5)$     b)  $5^x \cdot x^5 (5 + \log 5)$   
 c)  $5^x \cdot x^4 (5 + x \log 5)$     d)  $5^x \cdot x^5 (5 + x \log 5)$

6) If  $y = \log \left( \frac{e^x}{x^2} \right)$  then  $\frac{dy}{dx} = ?$

- a)  $\frac{2-x}{x}$       b)  $\frac{x-2}{x}$   
 c)  $\frac{e-x}{ex}$       d)  $\frac{x-e}{ex}$

7) If  $ax^2 + 2hxy + by^2 = 0$  then  $\frac{dy}{dx} = ?$

a)  $\frac{(ax + hy)}{(hx + by)}$       b)  $\frac{-(ax + hy)}{(hx + by)}$

c)  $\frac{(ax - hy)}{(hx + by)}$       d)  $\frac{(2ax + hy)}{(hx + 3by)}$

8) If  $x^4 \cdot y^5 = (x+y)^{(m+1)}$

and  $\frac{dy}{dx} = \frac{y}{x}$  then  $m = ?$

- a) 8    b) 4    c) 5    d) 20

9) If  $x = \frac{e^t + e^{-t}}{2}$ ,  $y = \frac{e^t - e^{-t}}{2}$  then  $\frac{dy}{dx} = ?$

- a)  $\frac{-y}{x}$     b)  $\frac{y}{x}$     c)  $\frac{-x}{y}$     d)  $\frac{x}{y}$

10) If  $x = 2at^2$ ,  $y = 4at$  then  $\frac{dy}{dx} = ?$

- a)  $-\frac{1}{2at^2}$       b)  $\frac{1}{2at^3}$   
 c)  $\frac{1}{t}$       d)  $\frac{1}{4at^3}$

#### Q.II] Fill in the blanks:

1) If  $3x^2y + 3xy^2 = 0$

then  $\frac{dy}{dx} =$

2) If  $x^m \cdot y^n = (x+y)^{(m+n)}$  then  $\frac{dy}{dx} = \frac{\text{.....}}{x}$

3) If  $0 = \log(xy) + a$  then  $\frac{dy}{dx} = \frac{-y}{\text{.....}}$

4) If  $x = t \log t$  and  $y = t^t$  then  $\frac{dy}{dx} = \text{.....}$

5) If  $y = x \cdot \log x$  then  $\frac{d^2y}{dx^2} = \text{.....}$

6) If  $y = [\log(x)]^2$  then  $\frac{d^2y}{dx^2} = \dots\dots$

7) If  $x = y + \frac{1}{y}$  then  $\frac{dy}{dx} = \dots\dots$

8) If  $y = e^{ax}$ , then  $x \cdot \frac{dy}{dx} = \dots\dots$

9) If  $x = t \cdot \log t$ ,  $y = t^t$  then  $\frac{dy}{dx} = \dots\dots$

10) If  $y = (x + \sqrt{x^2 - 1})^m$   
then  $\sqrt{(x^2 - 1)} \frac{dy}{dx} = \dots\dots$

3) If  $y = [\log(\log(\log x))]^2$ , find  $\frac{dy}{dx}$

4) Find the rate of change of demand (x) of a commodity with respect to its price (y) if  $y = 25 + 30x - x^2$ .

5) Find the rate of change of demand (x) of a commodity with respect to its price (y) if  $y = \frac{5x + 7}{2x - 13}$

6) Find  $\frac{dy}{dx}$ , if  $y = x^x$

7) Find  $\frac{dy}{dx}$ , if  $y = 2^{x^x}$

8) Find  $\frac{dy}{dx}$ , if  $y = \sqrt{\frac{(3x-4)^3}{(x+1)^4(x+2)}}$

**Q.III] State whether each of the following is True or False:**

1) The derivative of  $\log_a x$ , where a is constant is  $\frac{1}{x \cdot \log a}$ .

2) The derivative of  $f(x) = a^x$ , where a is constant is  $x \cdot a^{x-1}$

3) The derivative of polynomial is polynomial.

4)  $\frac{d}{dx}(10^x) = x \cdot 10^{x-1}$

5) If  $y = \log x$  then  $\frac{dy}{dx} = \frac{1}{x}$

6) If  $y = e^2$  then  $\frac{dy}{dx} = 2e$

7) The derivative of  $a^x$  is  $a^x \cdot \log a$

8) The derivative of  $x^m \cdot y^n = (x+y)^{(m+n)}$  is  $\frac{x}{y}$

9) Find  $\frac{dy}{dx}$ , if  $y = x^x + (7x - 1)^x$

10) If  $y = x^3 + 3xy^2 + 3x^2y$  Find  $\frac{dy}{dx}$

11) If  $x^3 + y^2 + xy = 7$  Find  $\frac{dy}{dx}$

12) If  $x^3y^3 = x^2 - y^2$  Find  $\frac{dy}{dx}$

13) If  $x^7 \cdot y^9 = (x+y)^{16}$  then show that  
Find  $\frac{dy}{dx} = \frac{y}{x}$

14) If  $x^a \cdot y^b = (x+y)^{(a+b)}$  then show that  
Find  $\frac{dy}{dx} = \frac{y}{x}$

15) Find  $\frac{dy}{dx}$  if,  $x = 5t^2$ ,  $y = 10t$

16) Find  $\frac{dy}{dx}$  if,  $x = e^{3t}$ ,  $y = e^{\sqrt{t}}$

17) Differentiate  $\log(1+x^2)$  with respect to  $a^x$

**Q.IV] Solve the following:**

1) If  $y = (6x^3 - 3x^2 - 9x)^{10}$ , find  $\frac{dy}{dx}$

2) If  $y = \sqrt[5]{(3x^2 + 8x + 5)^4}$ , find  $\frac{dy}{dx}$

18) Differentiate  $e^{(4x+5)}$  with respect to  $10^{4x}$

19) Find  $\frac{d^2y}{dx^2}$ , if  $y = \log(x)$

20) Find  $\frac{d^2y}{dx^2}$ , if  $y = 2at$ ,  $x = at^2$

21) Find  $\frac{d^2y}{dx^2}$ , if  $y = x^2 \cdot e^x$

22) If  $x^2 + 6xy + y^2 = 10$  then show

$$\text{that } \frac{d^2y}{dx^2} = \frac{80}{(3x+y)^3}$$

23) If  $ax^2 + 2hxy + by^2 = 0$  then show

$$\text{that } \frac{d^2y}{dx^2} = 0$$

### Activities

**(1):**  $y = (6x^4 - 5x^3 + 2x + 3)^5$  find  $\frac{dy}{dx}$

**Solution:-** Given

$$y = (6x^4 - 5x^3 + 2x + 3)^5$$

$$\text{Let } u = [6x^4 - 5x^3 + \square + 3]$$

$$\therefore y = u^\square$$

$$\therefore \frac{dy}{du} = 5u^4$$

$$\text{And } \frac{du}{dx} = 24x^3 - 15(\square) + 2$$

By chain rule

$$\frac{dy}{dx} = \frac{dy}{du} \times \frac{du}{dx}$$

$$\therefore \frac{dy}{dx} = 5(6x^4 - 5x^3 + 2x + 3)^\square$$

$$\times (24x^3 - 15x^2 + \square)$$

**(2):** The rate of change of demand (x) of a commodity with respect to its price (y).

$$\text{If } y = 30 + 25x + x^2$$

**Solution :** Let  $y = 30 + 25x + x^2$

Diff. w.r.to x, we get

$$\therefore \frac{dy}{dx} = \square + \square + \square$$

$$\therefore \frac{dy}{dx} = 25 + 2x$$

$\therefore$  By derivation of the inverse function

$$\frac{dx}{dy} = \frac{1}{\square}, \quad \frac{dy}{dx} \neq 0$$

Rate of change of demand with respect to

$$\text{price} = \frac{1}{\square + \square}$$

**(3):** find  $\frac{dy}{dx}$ , if  $y = x^{(\log x)} + 10^x$

**Solution:-** Let  $y = x^{(\log x)} + 10^x$

$$\text{Let } u = x^{\log x}, \quad v = 10^x$$

$$y = u + v$$

$$\text{Now, } u = x^{\log x}$$

Taking log on both sides, we get

$$\log u = \log x^{\log x}$$

$$\log u = \log x \cdot \log x$$

$$\log u = (\log x)^2$$

Diff. w.r.to x, we get

$$\therefore \frac{1}{u} \frac{du}{dx} = 2(\log x) \times \frac{d}{dx} \square$$

$$\therefore \frac{du}{dx} = u \left[ 2 \log x \times \frac{1}{x} \right]$$

$$\therefore \frac{du}{dx} = x^{\log x} \left[ 2 \square \times \frac{1}{\square} \right] \dots \dots \dots \text{(II)}$$

$$\text{Now, } v = 10^x$$

Diff.w.r.to x, we get

$$\therefore \frac{dv}{dt} = 10^x \square$$

Substitution equation (II) & (III) in equation (I), we get

$$\therefore \frac{dy}{dx} = x^{\log x} \left[ 2 \log x + \frac{1}{x} \right] + 10^x \cdot \log(10)$$

**(4):** Find  $\frac{dy}{dx}$ , if  $y^x = e^{x+y}$

**Solution:-** Given  $y^x = e^{x+y}$

Taking log on both side, we get,

$$\therefore \log (y)^x = \log (e)^{x+y}$$

$$\therefore x \cdot \log y = (x + y) \cdot \log e$$

$$\therefore x \cdot \log y = (x + y) \cdot 1$$

$$\therefore x \cdot \log y = x + y$$

Diff. w.r.to x, we get

$$\therefore x \frac{1}{y} \frac{d \log y}{dx} + \log y \cdot 1 = 1 + \frac{dy}{dx}$$

$$\therefore x \frac{1}{y} \frac{dy}{dx} + \log y = 1 + \frac{dy}{dx}$$

$$\therefore \frac{x}{y} \frac{dy}{dx} - \frac{dy}{dx} = 1 - \log y$$

$$\therefore \frac{dy}{dx} \left( \frac{x}{y} - 1 \right) = 1 - \log y$$

$$\therefore \frac{dy}{dx} = \frac{(1 - \log y) (y)}{x - y}$$

**5:** Find  $\frac{dy}{dx}$  if  $x = e^t$ ,  $y = e^{\sqrt{t}}$

**Solution:-** given,  $x = e^t$ ,  $y = e^{\sqrt{t}}$

$$\text{Now, } y = e^{\sqrt{t}}$$

Diff. w.r.to t

$$\therefore \frac{dy}{dt} = e^{\sqrt{t}} \frac{d \sqrt{t}}{dt}$$

$$\therefore \frac{dx}{dt} = e^{\sqrt{t}} \cdot \frac{1}{2\sqrt{t}} \quad \dots\dots\dots \text{(I)}$$

$$\text{Now, } x = e^t$$

Diff.w.r.to t

$$\therefore \frac{dx}{dt} = e^t \quad \dots\dots\dots \text{(II)}$$

$$\text{Now, } \frac{dy}{dx} = \frac{dy/dt}{dx/dt}$$

$$\therefore = \frac{e^{\sqrt{t}}}{e^t}$$

$$\therefore \frac{dy}{dx} = \frac{e^{\sqrt{t}}}{2\sqrt{t} e^t}$$





# 4

## Applications of Derivatives



### Let's Study

- Meaning of Derivatives
- Increasing and Decreasing Functions.
- Maxima and Minima
- Application of derivatives to Economics.



### Introduction

Derivatives have a wide range of applications in everyday life. In this chapter, we shall discuss geometrical and physical significance of derivatives and some of their applications such as equation of tangent and normal at a point on the curve, rate measure in physical field, approximate values of functions and extreme values of a function.



### Let's Learn

#### 4.1 Meaning of Derivative:

Let  $y = f(x)$  be a continuous function of  $x$ . It represents a curve in XY-plane. (fig. 4.1).

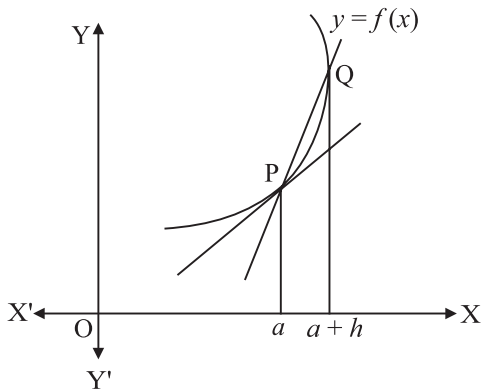

Fig. 4.1

Let  $P(a, f(a))$  and  $Q(a + h, f(a + h))$  be two points on the curve. Join the points P and Q.

$$\text{The slope of the chord PQ} = \frac{f(a + h) - f(a)}{h}$$

Let the point Q move along the curve such that  $Q \rightarrow P$ . Then the secant PQ approaches the tangent at P as  $h \rightarrow 0$

$$\therefore \lim_{Q \rightarrow P} (\text{slope of secant PQ}) = \lim_{h \rightarrow 0} \frac{f(a + h) - f(a)}{h}$$

Slope of tangent at P =  $f'(a)$  (if limit exists)

Thus, the derivative of a function  $y = f(x)$  at any point  $P(a, b)$  is the slope of the tangent at the point  $P(a, b)$  on the curve.

The slope of the tangent at any point  $P(a, b)$  is also called gradient of the curve  $y = f(x)$  at point P and is denoted by  $f'(a)$  or  $\left(\frac{dy}{dx}\right)_P$ .

Normal is a line perpendicular to tangent, passing through the point of tangency.

$\therefore$  Slope of the normal is the negative reciprocal of slope of tangent.

$$\text{Thus, slope of normal} = \frac{-1}{f'(a)} = \frac{-1}{\left(\frac{dy}{dx}\right)_P}$$

Hence,

(i) The equation of tangent to the curve  $y = f(x)$  at the point  $P(a, b)$  is given by  $(y - b) = f'(a)(x - a)$

(ii) The equation of normal to the curve  $y = f(x)$  at the point  $P(a, b)$  is given by

$$(y - b) = \frac{-1}{f'(a)} (x - a)$$

## SOLVED EXAMPLES

- 1) Find the equation of tangent and normal to the curve  $y = x^2 + 4x + 1$  at  $P(-1, -2)$ .

**Solution:** Given equation of curve is

$$y = x^2 + 4x + 1$$

Differentiating with respect to  $x$

$$\therefore \frac{dy}{dx} = 2x + 4$$

$$\therefore \left( \frac{dy}{dx} \right)_{p(-1,-2)} = 2(-1) + 4$$

$$= 2$$

$\therefore$  The slope of tangent at  $P(-1, -2)$  is 2

$\therefore$  The equation of tangent is

$$y + 2 = 2(x + 1)$$

$$\therefore y + 2 = 2x + 2$$

$$\therefore 2x - y = 0$$

Now, The slope of Normal at

$$P(-1, -2) \text{ is } \frac{-1}{2}$$

$\therefore$  The equation of normal is

$$y + 2 = \frac{-1}{2}(x + 1)$$

$$2(y + 2) = -1(x + 1)$$

$$2y + 4 = -x - 1$$

$$x + 2y + 5 = 0$$

- 2) Find the equation of tangent and normal to the curve  $y = 6 - x^2$  where the normal is parallel to the line  $x - 4y + 3 = 0$ .

**Solution:** Let  $P(x_1, y_1)$  be the point on the curve  $y = 6 - x^2$  where the normal is parallel to the line  $x - 4y + 3 = 0$

Consider,  $y = 6 - x^2$

$$\therefore \frac{dy}{dx} = -2x$$

$$\therefore \left( \frac{dy}{dx} \right)_{x=x_1} = -2x_1$$

$\therefore$  The slope of the tangent as  $P(x_1, y_1)$   $= -2x_1$

$\therefore$  The slope of the normal at  $P(x_1, y_1)$   $= \frac{1}{2x_1}$

Now, slope of  $x - 4y + 3 = 0$  is  $\frac{1}{4}$

$\therefore$  The slope of the normal  $= \frac{1}{4}$  (since normal is parallel to given line)

$$\therefore \frac{1}{2x_1} = \frac{1}{4}$$

$$\therefore x_1 = 2$$

$P(x_1, y_1)$  lies on the curve  $y = 6 - x^2$

$$\therefore y_1 = 6 - x_1^2$$

$$\therefore y_1 = 6 - 4$$

$$\therefore y_1 = 2$$

$\therefore$  The point on the curve is  $(2, 2)$

$\therefore$  The slope of tangent at  $(2, 2)$  is  $-2x_1 = -2(2) = -4$

$\therefore$  The equation of tangent is  $(y - 2) = -4(x - 2)$

$$\therefore y - 2 = -4x + 8$$

$$\therefore 4x + y - 10 = 0$$

$\therefore$  The equation of normal is

$$(y - 2) = \frac{1}{4}(x - 2)$$

$$\therefore 4(y - 2) = 1(x - 2)$$

$$\therefore 4y - 8 = x - 2$$

$$\therefore x - 4y + 6 = 0$$

### EXERCISE 4.1

Q.1 Find the equation of tangent and normal to the curve at the given points on it.

i)  $y = 3x^2 - x + 1$  at  $(1,3)$

ii)  $2x^2 + 3y^2 = 5$  at  $(1,1)$

iii)  $x^2 + y^2 + xy = 3$  at  $(1,1)$

Q.2 Find the equation of tangent and normal to the curve  $y = x^2 + 5$  where the tangent is parallel to the line  $4x - y + 1 = 0$ .

Q.3 Find the equation of tangent and normal to the curve  $y = 3x^2 - 3x - 5$  where the tangent is parallel to the line  $3x - y + 1 = 0$ .

#### 4.2 Increasing and Decreasing Functions:

**Definition :** The function  $y = f(x)$  is said to be an increasing function of  $x$  in the interval  $(a,b)$  if  $f(x_2) > f(x_1)$ , whenever  $x_2 > x_1$  in the interval  $(a,b)$ .

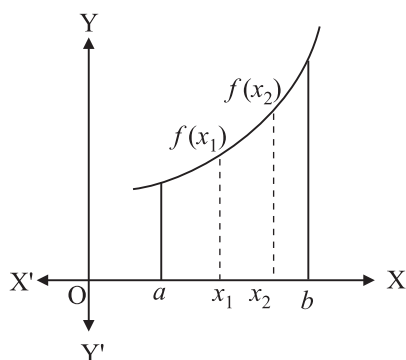

**Fig. 4.2**

Geometrically, as we move from left to right along the curve  $y = f(x)$  in  $(a,b)$ , then the curve rises. (see fig. 4.2)

$\therefore$  Slope of tangent at  $x: f'(x) > 0$

$\therefore$  The slope of the tangent is positive.

If  $f'(x) > 0$  for all  $x \in (a,b)$  then,  $y = f(x)$  is an increasing function in the interval  $(a,b)$

**Note:** Sign of the Derivative can be used to find if the function  $f(x)$  is increasing.

**Definition:** A function  $y = f(x)$  is said to be a decreasing function of  $x$  in an interval  $(a,b)$ , if  $f(x_2) < f(x_1)$ , whenever  $x_2 > x_1$  for all  $x_1, x_2$  in the interval  $(a, b)$ .

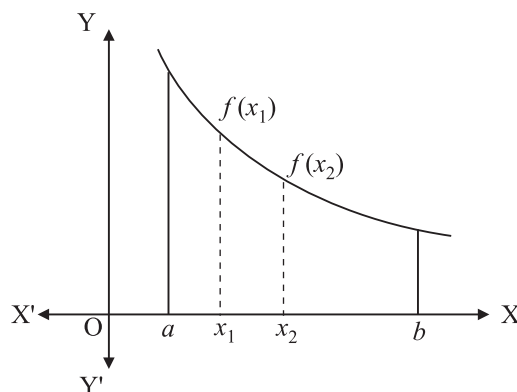

**Fig. 4.3**

Geometrically, as we move from left to right along the curve  $y = f(x)$  in  $(a,b)$ , then the curve falls. (see fig.4.3)

$\therefore$  Slope of tangent  $f'(x) < 0$

$\therefore$  The slope of tangent is negative.

If  $f'(x) < 0$  in  $(a,b)$  then  $f(x)$  is a decreasing function in the interval  $(a,b)$ .

**Note:** Every function may not be either increasing or decreasing.

### SOLVED EXAMPLES

1) Test whether the following function is increasing or decreasing.

$$f(x) = x^3 - 3x^2 + 3x - 100, x \in \mathbb{R}$$

**Solution:** Given  $f(x) = x^3 - 3x^2 + 3x - 100, x \in \mathbb{R}$

$\therefore f'(x) = 3x^2 - 6x + 3$

$\therefore f'(x) = 3(x - 1)^2$

Since  $(x - 1)^2$  is always positive,  $x \neq 1$

$\therefore f'(x) > 0, \forall x \in \mathbb{R} - \{1\}$

Hence,  $f(x)$  is an increasing function,  $\forall x \in \mathbb{R} - \{1\}$

2) Test whether the following function is increasing or decreasing.

$$f(x) = 2 - 3x + 3x^2 - x^3, \forall x \in \mathbb{R}$$

**Solution:**  $f(x) = 2 - 3x + 3x^2 - x^3$

$$\therefore f'(x) = -3 + 6x - 3x^2$$

$$\therefore f'(x) = -3(x^2 - 2x + 1)$$

$$\therefore f'(x) = -3(x - 1)^2$$

Since  $(x - 1)^2$  is always positive,  $x \neq 1$

$$\therefore f'(x) < 0, \forall x \in \mathbb{R} - \{1\}$$

Hence, function  $f(x)$  is decreasing function  $\forall x \in \mathbb{R} - \{1\}$

3) Find the value of  $x$ , for which the function  $f(x) = x^3 + 12x^2 + 36x + 6$  is increasing.

**Solution:** Given  $f(x) = x^3 + 12x^2 + 36x + 6$

$$\therefore f'(x) = 3x^2 + 24x + 36$$

$$\therefore f'(x) = 3(x + 2)(x + 6)$$

Now,  $f'(x) > 0$ , as  $f(x)$  is increasing.

$$\therefore 3(x + 2)(x + 6) > 0$$

( $ab > 0 \Leftrightarrow a > 0, b > 0$  or  $a < 0, b < 0$ )

Case I]  $x + 2 > 0$  and  $x + 6 > 0$

$$\therefore x > -2 \text{ and } x > -6$$

$$\therefore x > -2 \quad \dots\dots\dots \text{(I)}$$

Case II]  $x + 2 < 0$  and  $x + 6 < 0$

$$\therefore x < -2 \text{ and } x < -6$$

$$\therefore x < -6 \quad \dots\dots\dots \text{(II)}$$

From case I and II,  $f(x)$  is increasing if  $x < -6$  or  $x > -2$

$\therefore f(x) = x^3 + 12x^2 + 36x + 6$  is increasing if and only if  $x < -6$  or  $x > -2$

Hence,  $x \in (-\infty, -6)$  or  $x \in (-2, \infty)$ .

4) Find the values of  $x$  for which the function  $f(x) = 2x^3 - 9x^2 + 12x + 2$  is decreasing.

**Solution:** Given  $f(x) = 2x^3 - 9x^2 + 12x + 2$

$$\therefore f'(x) = 6x^2 - 18x + 12$$

$$\therefore f'(x) = 6(x - 1)(x - 2)$$

Now,  $f'(x) < 0$

$$\therefore 6(x - 1)(x - 2) < 0$$

(if  $ab < 0$  either  $a < 0$  and  $b > 0$  or  $a > 0$  and  $b < 0$ )

Case I]  $(x - 1) < 0$  and  $x - 2 > 0$

$\therefore x < 1$  and  $x > 2$  which is contradiction

Case II]  $x - 1 > 0$  and  $x - 2 < 0$

$$\therefore x > 1 \text{ and } x < 2$$

$$\therefore 1 < x < 2$$

$\therefore f(x) = 2x^3 - 9x^2 + 12x + 2$  is decreasing function if  $x \in (1, 2)$ .

### EXERCISE 4.2

Q.1 Test whether the following functions are increasing or decreasing

i)  $f(x) = x^3 - 6x^2 + 12x - 16, x \in \mathbb{R}$

ii)  $f(x) = x - \frac{1}{x}, x \in \mathbb{R}, x \neq 0$

iii)  $f(x) = \frac{7}{x} - 3, x \in \mathbb{R}, x \neq 0$

Q.2 Find the values of  $x$ , such that  $f(x)$  is increasing function.

i)  $f(x) = 2x^3 - 15x^2 + 36x + 1$

ii)  $f(x) = x^2 + 2x - 5$

iii)  $f(x) = 2x^3 - 15x^2 - 144x - 7$

Q.3 Find the values of  $x$  such that  $f(x)$  is decreasing function.

i)  $f(x) = 2x^3 - 15x^2 - 144x - 7$

ii)  $f(x) = x^4 - 2x^3 + 1$

iii)  $f(x) = 2x^3 - 15x^2 - 84x - 7$

### 4.3 Maxima and Minima:

**a) Maximum value of  $f(x)$ :** A function  $f(x)$  is said to have a maximum value at a point  $x = c$  if  $f(x) \leq f(c)$  for all  $x \neq c$ .

The value  $f(c)$  is called the maximum value of  $f(x)$ .

Thus, the function  $f(x)$  will have a maximum at  $x = c$  if  $f(x)$  is increasing for  $x < c$  and  $f(x)$  is decreasing for  $x > c$  as shown in Fig. 4.4

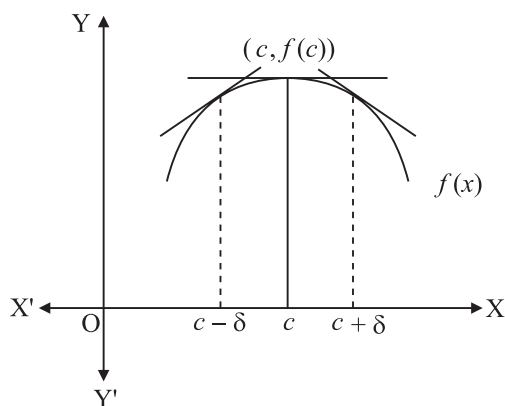

Fig. 4.4

b) **Minimum value of  $f(x)$ :** A function  $f(x)$  is said to have a minimum at a point  $x = c$  if  $f(x) > f(c)$  for all  $x \neq c$ .

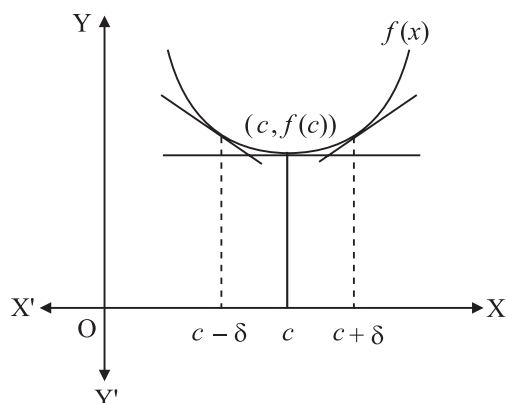

Fig. 4.5

The value of  $f(c)$  is called the minimum value of  $f(x)$ .

The function will have a minimum at  $x = c$  if  $f(x)$  is decreasing for  $x < c$  and  $f(x)$  is increasing for  $x > c$  as shown in fig. 4.5

At  $x = c$  if the function is neither increasing nor decreasing, then the function is stationary at  $x = c$

**Note:** The maximum and minimum values of a function are called its extreme values.

To find extreme values of a function, we use the following tests.

**Test for maximum / minimum :** For a real valued function  $f$ , defined on  $[a, b]$  and differentiable on  $(a, b)$ , then for  $c \in (a, b)$

- i)  $x = c$  is a point of local maxima, if  $f'(c) = 0$  and  $f''(c) < 0$ . The value  $f(c)$  is local maximum value of  $f$ .
- ii)  $x = c$  is a point of local minima, if  $f'(c) = 0$  and  $f''(c) > 0$ . In this case  $f(c)$  is local minimum value of  $f$ .

**Remark :**

If  $f'(c) = 0$  and  $f'(c-h) > 0, f'(c+h) > 0$  or  $f'(c-h) < 0, f'(c+h) < 0$  then  $f(c)$  is neither maximum nor minimum. In this case  $x = c$  is called a **point of inflection** (see.fig. 4.6)

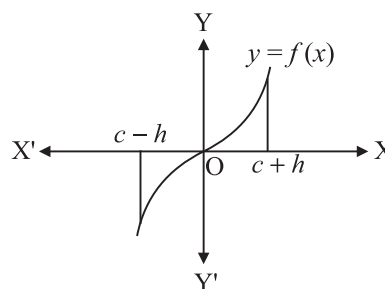

Fig. 4.6

A function may have several maxima and several minima. In such cases, the maxima are called **local maxima** and the minima are called **local minima**. (see. fig. 4.7)

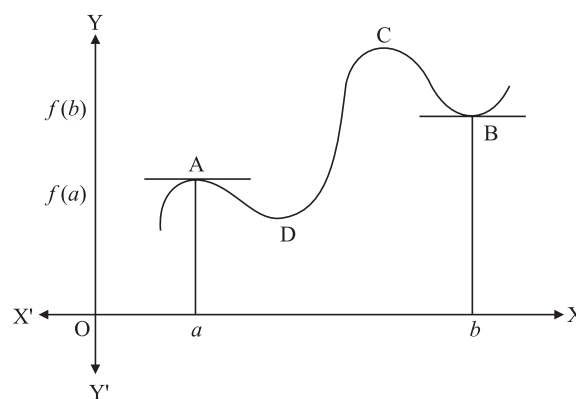

Fig. 4.7

In this figure the function has a local maximum at  $x = a$  and a local minimum at  $x = b$  and still  $f(b) > f(a)$ .

**SOLVED EXAMPLES**

- 1) Find the maximum and minimum value of the function

$$f(x) = 3x^3 - 9x^2 - 27x + 15$$

**Solution:** Given  $f(x) = 3x^3 - 9x^2 - 27x + 15$

$$\therefore f'(x) = 9x^2 - 18x - 27$$

$$\therefore f''(x) = 18x - 18$$

For the extreme values  $f'(x) = 0$

$$\therefore 9x^2 - 18x - 27 = 0$$

$$\therefore 9(x^2 - 2x - 3) = 0$$

$$\therefore (x + 1)(x - 3) = 0$$

$$\therefore x = -1 \text{ or } x = 3$$

For  $x = -1$ ,  $f''(x) = 18x - 18$

$$f''(-1) = 18(-1) - 18$$

$$= -18 - 18$$

$$= -36 < 0$$

$$\therefore f(x) \text{ attains maximum at } x = -1$$

Maximum value is

$$f(-1) = 3(-1)^3 - 9(-1)^2 - 27(-1) + 15 = 30$$

For  $x = 3$ ,  $f''(x) = 18x - 18$

$$f''(3) = 18(3) - 18$$

$$= 54 - 18$$

$$= 36 > 0$$

$$\therefore f(x) \text{ attains minimum at } x = 3$$

Minimum value is,

$$f(3) = 3(3)^3 - 9(3)^2 - 27(3) + 15 = -66$$

$\therefore$  The function  $f(x)$  has maximum value 30 at  $x = -1$  and minimum value  $-66$  at  $x = 3$

- 2) Divide the number 84 into two parts such that the product of one part and square of the other is maximum.

**Solution:** Let one part be  $x$  then other part will be  $84 - x$

$$f(x) = x^2(84 - x)$$

$$f(x) = 84x^2 - x^3$$

$$f'(x) = 168x - 3x^2$$

$$f''(x) = 168 - 6x$$

For extreme value  $f'(x) = 0$

$$\therefore 168x - 3x^2 = 0$$

$$\therefore 3x(56 - x) = 0$$

$$x = 0 \text{ or } x = 56$$

If  $x = 0$ ,  $f''(x) = 168 - 6x$

$$f''(0) = 168 - 6(0)$$

$$= 168 > 0$$

$$\therefore f(x) \text{ attains minimum at } x = 0$$

If  $x = 56$ ,  $f''(x) = 168 - 6x$

$$f''(x) = 168 - 6(56)$$

$$= -168 < 0$$

$$\therefore f(x) \text{ attains maximum at } x = 56$$

$$\therefore \text{Two parts of 84 are 56 and 28}$$

- 3) A rod of 108 meter long is bent to form a rectangle. Find it's dimensions if the area is maximum.

**Solution:** Let  $x$  be the length and  $y$  be the breadth of the rectangle.

$$\therefore 2x + 2y = 108$$

$$\therefore 2y = 108 - 2x$$

$$\therefore 2y = 2(54 - x)$$

$$\therefore y = 54 - x \quad \dots\dots\dots (1)$$

Now, area of the rectangle =  $xy$

$$= x(54 - x)$$

$$f(x) = 54x - x^2$$

$$f'(x) = 54 - 2x$$

$$f''(x) = -2$$

For extreme value,  $f'(x) = 0$

$$\therefore 54 - 2x = 0$$

$$\therefore 2x = 54$$

$$\therefore x = 27$$

$$f''(27) = -2 < 0$$

$\therefore$  Area is maximum when  $x = 27, y = 27$

$\therefore$  The dimension of rectangle are  $27\text{m} \times 27\text{m}$ .

$\therefore$  It is a square.

### EXERCISE 4.3

Q.1 Determine the maximum and minimum values of the following functions.

i)  $f(x) = 2x^3 - 21x^2 + 36x - 20$

ii)  $f(x) = x \cdot \log x$

iii)  $f(x) = x^2 + \frac{16}{x}$

Q.2 Divide the number 20 in to two parts such that their product is maximum.

Q.3 A metal wire of 36cm long is bent to form a rectangle. Find it's dimensions when it's area is maximum.

Q.4 The total cost of producing  $x$  units is Rs.  $(x^2 + 60x + 50)$  and the price is Rs.  $(180 - x)$  per unit. For what units is the profit maximum?

#### 4.4 Applications of derivative in Economics:

We ave discussed the following functions in XIth standard.

1. Demand Function  $D = f(P)$ .

$$\text{Marginal demand} = D_m = \frac{dD}{dP}$$

2. Supply function  $S = g(P)$

$$\text{Marginal supply} = \frac{dS}{dP}$$

3. Total cost function  $C = f(x)$ , where  $x$  is number of items produced,

$$\text{Marginal cost} = C_m = \frac{dC}{dx}$$

$$\text{Average cost} = C_A = \frac{C}{x}$$

4. Total Revenue  $R = P \cdot D$  where  $P$  is price and  $D$  is demand.

$$\text{Average Revenue } R_A = \frac{R}{D} = \frac{PD}{D} = P$$

$$\text{Total profit} = R - C$$

With this knowledge, we are now in a position to discuss price elasticity of demand; which is usually referred as 'elasticity of demand' denoted by ' $\eta$ '.

$$\text{Elasticity of demand } \eta = \frac{-P}{D} \cdot \frac{dD}{dP}$$

We observe the following situations in the formula for elasticity of demand.

i) Demand is a decreasing function of price.

$$\therefore \frac{dD}{dP} < 0$$

Also, price  $P$  and the demand  $D$  are always positive.

$$\therefore \eta = \frac{-P}{D} \cdot \frac{dD}{dP} > 0$$

ii) If  $\eta = 0$ , it means the demand  $D$  is constant function of price  $P$ .

$$\therefore \frac{dD}{dP} < 0$$

In this situation demand is perfectly inelastic.

iii) If  $0 < \eta < 1$ , the demand is relatively inelastic.

iv) If  $\eta = 1$ , the demand is exactly proportional to the price and demand is said to be unitary elastic.

v) If  $\eta > 1$ , the demand is relatively elastic.

Now let us establish the relation between marginal revenue ( $R_m$ ), average revenue ( $R_A$ ) and elasticity of demand ( $\eta$ )

$$\text{As, } R_m = \frac{dR}{dD}$$

$$\text{But } R = P.D.$$

$$\begin{aligned} \therefore R_m &= \frac{d}{dD}(P.D) \\ &= P + D \frac{dP}{dD} \\ &= P \left( 1 + \frac{D}{P} \frac{dP}{dD} \right) \quad \dots\dots (1) \end{aligned}$$

$$\text{But } \eta = \frac{-P}{D} \cdot \frac{dD}{dP}$$

$$\frac{-1}{\eta} = \frac{D}{P} \cdot \frac{dP}{dD}$$

Substituting in (1) we get,

$$R_m = P \left( 1 - \frac{1}{\eta} \right)$$

$$R_m = R_A \left( 1 - \frac{1}{\eta} \right) \quad (\text{as } R_A = P)$$

**Marginal propensity to consume:** For any person with income  $x$ , his consumption expenditure ( $E_c$ ) depends on  $x$ .

$$\therefore E_c = f(x)$$

Marginal propensity to consume

$$(\text{MPC}) = \frac{dE_c}{dx}$$

Average propensity to consume

$$(\text{APC}) = \frac{E_c}{x}$$

Marginal propensity to save (MPS): If  $S$  is a saving of a person with income  $x$  then

$$\text{MPS} = \frac{dS}{dx}$$

$$\text{Average propensity to save (APS)} = \frac{S}{x}$$

Note here that  $x = E_c + S$

Differentiating both sides w.r.t.  $x$

$$1 = \frac{dE_c}{dx} + \frac{dS}{dx}$$

$$\therefore \text{MPC} + \text{MPS} = 1$$

Also as  $x = E_c + S$ ,

$$\therefore 1 = \frac{E_c}{x} + \frac{S}{x}$$

$$\therefore 1 = \text{APC} + \text{APS}$$

### SOLVED EXAMPLES

- 1) The revenue function is given by  $R = D^2 - 40D$ , where  $D$  is demand of the commodity. For what values of  $D$ , the revenue is increasing?

**Solution:** Given  $R = D^2 - 40D$

Differentiating w.r.t.  $D$

$$\frac{dR}{dD} = 2D - 40$$

As revenue is increasing

$$\therefore \frac{dR}{dD} > 0$$

$$\therefore 2D - 40 > 0$$

$$\therefore D > 20$$

Revenue is increasing for  $D > 20$

- 2) The cost  $C$  of producing  $x$  articles is given as  $C = x^3 - 16x^2 + 47x$ . For what values of  $x$  the average cost is decreasing?

**Solution:** Given  $C = x^3 - 16x^2 + 47x$

$$\text{Average cost } C_A = \frac{C}{x}$$

$$C_A = x^2 - 16x + 47$$

Differentiating w.r.t.  $x$



$$\frac{dC_A}{dx} = 2x - 16$$

Now  $C_A$  is decreasing if  $\frac{dC_A}{dx} < 0$

that is  $2x - 16 < 0$

$$\therefore x < 8$$

Average cost is decreasing for  $x < 8$

- 3) In a factory, for production of  $Q$  articles, standing charges are 500/-, labour charges are 700/- and processing charges are 50Q. The price of an article is  $1700 - 3Q$ . For what values of  $Q$ , the profit is increasing?

**Solution:** Cost of production of  $Q$  articles

$C =$  standing charges + labour charges + processing charges

$$\therefore C = 500 + 700 + 50Q$$

$$\therefore C = 1200 + 50Q$$

Revenue  $R = P \cdot Q$ .

$$= (1700 - 3Q) Q$$

$$= 1700Q - 3Q^2$$

Profit  $\pi = R - C$

$$= 1700Q - 3Q^2 - (1200 + 50Q)$$

$$\therefore \pi = 1650Q - 3Q^2 - 1200$$

Differentiating w.r.t.  $Q$ ,

$$\frac{d\pi}{dQ} = 1650 - 6Q$$

If profit is increasing, then  $\frac{d\pi}{dQ} > 0$

$$\therefore 1650 - 6Q > 0$$

That is  $1650 > 6Q$

$$\therefore Q < 275$$

$$\therefore \text{Profit is increasing for } Q < 275$$

- 4) Demand function  $x$ , for a certain commodity is given as  $x = 200 - 4p$ , where  $p$  is the unit price. Find
- elasticity of demand as a function of  $p$ .
  - elasticity of demand when  $p = 10$ ;  $p = 30$ . Interpret your results.

- iii) the price  $p$  for which elasticity of demand is equal to one.

**Solution:** (i) Elasticity of demand

$$\eta = \frac{-p}{x} \cdot \frac{dx}{dp}$$

For  $x = 200 - 4p$ ,

$$\frac{dx}{dp} = -4$$

$$\therefore \eta = \frac{-p}{x} \cdot \frac{dx}{dp}$$

$$= \frac{-p}{(200 - 4p)} (-4) \quad (\text{For } p < 50)$$

$$\therefore \eta = \frac{p}{(50 - p)} \quad (\text{For } p < 50)$$

(ii) When  $P = 10$

$$\eta = \frac{10}{(50 - 10)}$$

$$= \frac{10}{40}$$

$$= 0.25 < 1$$

$\therefore$  Demand is inelastic for  $p = 10$

When  $p = 30$

$$\eta = \frac{30}{(50 - 30)}$$

$$\eta = \frac{30}{20}$$

$$= 1.5 > 1$$

$\therefore$  Demand is elastic when  $p = 30$

(iii) To find the price when  $\eta = 1$

As  $\eta = 1$ ,

$$\therefore \frac{p}{50 - p} = 1$$

$$\therefore p = 50 - p$$

$$\therefore 2p = 50$$

$$\therefore p = 25$$

$\therefore$  For elasticity equal to 1 then price is 25/unit.

- 5) If the average revenue  $R_A$  is 50 and elasticity of demand  $\eta$  is 5, find marginal revenue  $R_m$ .

**Solution:** Given  $R_A = 50$  and  $\eta = 5$ ,

$$R_m = R_A \left(1 - \frac{1}{\eta}\right)$$

$$= 50 \left(1 - \frac{1}{5}\right)$$

$$= 50 \left(\frac{4}{5}\right)$$

$$R_m = 40$$

- 6) The consumption expenditure  $E_c$  of a person with income  $x$ , is given by

$E_c = 0.0006x^2 + 0.003x$ . Find average propensity to consume, marginal propensity to consume when his income is Rs. 200/- Also find his marginal propensity to save.

**Solution:** Given  $E_c = 0.0006x^2 + 0.003x$

$$\therefore \text{APC} = \frac{E_c}{x}$$

$$= 0.0006x + 0.003$$

At  $x = 200$ ,

$$\text{APC} = 0.0006 \times 200 + 0.003$$

$$= 0.12 + 0.003$$

$$= 0.123$$

$$\text{MPC} = \frac{dE_c}{dx}$$

$$= \frac{d}{dx}(0.0006x^2 + 0.003x)$$

$$= 0.0006(2x) + 0.003$$

At  $x = 200$ ,

$$\text{MPC} = 0.0006 \times 400 + 0.003$$

$$= 0.24 + 0.003$$

$$= 0.243$$

$$\text{As } \text{MPC} + \text{MPS} = 1$$

$$\therefore \text{MPS} = 1 - \text{MPC}$$

$$= 1 - 0.243$$

$$= 0.757$$

#### EXERCISE 4.4

- The demand function of a commodity at price is given as,  $D = 40 - \frac{5P}{8}$ . Check whether it is increasing or decreasing function.
- The price  $P$  for demand  $D$  is given as  $P = 183 + 120D - 3D^2$ ; find  $D$  for which price is increasing.
- The total cost function for production of articles is given as  $C = 100 + 600x - 3x^2$ . Find the values of  $x$  for which total cost is decreasing.
- The manufacturing company produces  $x$  items at the total cost of Rs.  $180 + 4x$ . The demand function for this product is  $P = (240 - x)$ . Find  $x$  for which (i) revenue is increasing, (ii) profit is increasing.
- For manufacturing  $x$  units, labour cost is  $150 - 54x$  and processing cost is  $x^2$ . Price of each unit is  $p = 10800 - 4x^2$ . Find the values of  $x$  for which.
  - Total cost is decreasing
  - Revenue is increasing
- The total cost of manufacturing  $x$  articles  $C = 47x + 300x^2 - x^4$ . Find  $x$ , for which average cost is (i) increasing (ii) decreasing.
- Find the marginal revenue, if the average revenue is 45 and elasticity of demand is 5.
  - Find the price, if the marginal revenue is 28 and elasticity of demand is 3.
  - Find the elasticity of demand, if the marginal revenue is 50 and price is Rs. 75/-.
- If the demand function is  $D = \left(\frac{p+6}{p-3}\right)$ , find the elasticity of demand at  $p = 4$ .

- 9) Find the price for the demand function  $D = \frac{2p+3}{3p-1}$ , when elasticity of demand is  $\frac{11}{14}$ .
- 10) If the demand function is  $D = 50 - 3p - p^2$ . Find the elasticity of demand at (i)  $p = 5$  (ii)  $p = 2$ . Comment on the result.
- 11) For the demand function  $D = 100 - \frac{p^2}{2}$ . Find the elasticity of demand at (i)  $p = 10$  (ii)  $p = 6$  and comment on the results.
- 12) A manufacturing company produces  $x$  items at a total cost of Rs.  $40 + 2x$ . Their price is given as  $p = 120 - x$ . Find the value of  $x$  for which (i) revenue is increasing. (ii) profit is increasing. (iii) Also find elasticity of demand for price 80.
- 13) Find MPC, MPS, APC and APS, if the expenditure  $E_c$  of a person with income  $I$  is given as
- $$E_c = (0.0003)I^2 + (0.075)I$$
- when  $I = 1000$ .



### Let's Remember

- A function  $f$  is said to be increasing at a point  $c$  if  $f'(c) > 0$ .
- A function  $f$  is said to be decreasing at a point  $c$  if  $f'(c) < 0$ .
- Elasticity of demand  $\eta = \frac{-P}{D} \cdot \frac{dD}{dP}$
- $R_m = P \left(1 - \frac{1}{\eta}\right) = R_A \left(1 - \frac{1}{\eta}\right)$
- For a person with income  $x$ , consumption or expenditure  $E_c$  and saving  $S$ ,
  - $x = E_c + S$
  - $MPC + MPS = 1$
  - $APC + APS = 1$
- A function  $y = f(x)$  is said to have local maximum at  $x = c$ , if  $f'(c) = 0$  and  $f''(c) < 0$ .
- A function  $y = f(x)$  is said to have local minimum at  $x = c$ , if  $f'(c) = 0$  and  $f''(c) > 0$ .

### MISCELLANEOUS EXERCISE - 4

#### I) Choose the correct alternative.

- The equation of tangent to the curve  $y = x^2 + 4x + 1$  at  $(-1, -2)$  is
  - $2x - y = 0$
  - $2x + y - 5 = 0$
  - $2x - y - 1 = 0$
  - $x + y - 1 = 0$
- The equation of tangent to the curve  $x^2 + y^2 = 5$  where the tangent is parallel to the line  $2x - y + 1 = 0$  are
  - $2x - y + 5 = 0; 2x - y - 5 = 0$
  - $2x + y + 5 = 0; 2x + y - 5 = 0$
  - $x - 2y + 5 = 0; x - 2y - 5 = 0$
  - $x + 2y + 5; x + 2y - 5 = 0$
- If elasticity of demand  $\eta = 1$  then demand is
  - constant
  - in elastic
  - unitary elastic
  - elastic
- If  $0 < \eta < 1$ , then the demand is
  - constant
  - in elastic
  - unitary elastic
  - elastic
- The function  $f(x) = x^3 - 3x^2 + 3x - 100$ ,  $x \in \mathbb{R}$  is
  - Increasing for all  $x \in \mathbb{R}$ ,  $x \neq 1$
  - decreasing
  - Neither, increasing nor decreasing
  - Decreasing for all  $x \in \mathbb{R}$ ,  $x \neq 1$
- If  $f(x) = 3x^3 - 9x^2 - 27x + 15$  then
  - $f$  has maximum value 66
  - $f$  has minimum value 30
  - $f$  has maxima at  $x = -1$
  - $f$  has minima at  $x = -1$

**II) Fill in the blanks:**

- 1) The slope of tangent at any point (a,b) is called as .....
- 2) If  $f(x) = x^3 - 3x^2 + 3x - 100$ ,  $x \in \mathbb{R}$  then  $f''(x)$  is .....
- 3) If  $f(x) = \frac{7}{x} - 3$ ,  $x \in \mathbb{R}$ ,  $x \neq 0$  then  $f''(x)$  is .....
- 4) A rod of 108m length is bent to form a rectangle. If area at the rectangle is maximum then its dimension are .....
- 5) If  $f(x) = x \cdot \log x$  then its maximum value is .....

**III) State whether each of the following is True or false:**

- 1) The equation of tangent to the curve  $y = 4xe^x$  at  $(-1, -\frac{4}{e})$  is y.e.  $+4 = 0$ .
- 2)  $x + 10y + 21 = 0$  is the equation of normal to the curve  $y = 3x^2 + 4x - 5$  at (1,2).
- 3) An absolute maximum must occur at a critical point or at an end point.

**IV) Solve the following.**

- 1) Find the equation of tangent and normal to the following curves
  - i)  $xy = c^2$  at  $(ct, \frac{c}{t})$  where t is parameter
  - ii)  $y = x^2 + 4x$  at the point whose ordinate is -3
  - iii)  $x = \frac{1}{t}$ ,  $y = t - \frac{1}{t}$ , at  $t = 2$
  - iv)  $y = x^3 - x^2 - 1$  at the point whose abscissa is -2.
- 2) Find the equation of normal to the curve  $y = \sqrt{x-3}$  which is perpendicular to the line

$$6x + 3y - 4 = 0$$

- 3) Show that the function  $f(x) = \frac{x-2}{x+1}$ ,  $x \neq -1$  is increasing
- 4) Show that the function  $f(x) = \frac{3}{x} + 10$ ,  $x \neq 0$  is decreasing
- 5) If  $x + y = 3$  show that the maximum value of  $x^2y$  is 4.
- 6) Examine the function for maxima and minima  $f(x) = x^3 - 9x^2 + 24x$

**Activities**

- (1)** Find the equation of tangent to the curve  $\sqrt{x} - \sqrt{y} = 1$  at P(9,4).

**Solution :** Given equation of curve is

$$\sqrt{x} - \sqrt{y} = 1$$

Diff. w.r.to x

$$\therefore \frac{1}{2\sqrt{x}} - \frac{1}{2} \frac{dy}{dx} = 0$$

$$\therefore \frac{1}{2\sqrt{y}} \frac{dy}{dx} = \frac{1}{2} \square$$

$$\therefore \frac{1}{\sqrt{y}} \frac{dy}{dx} = \frac{1}{\sqrt{x}}$$

$$\therefore \frac{dy}{dx} = \frac{\sqrt{y}}{\sqrt{x}}$$

$$\therefore \left(\frac{dy}{dx}\right)_{P=(9,4)} = \frac{\sqrt{9}}{\square} = \frac{3}{2}$$

$$\therefore \text{slope of tangent is } \frac{3}{2}$$

$\therefore$  Equation of the tangent at P(9,4) is

$$y - 4 = \square (x - 9)$$

$$\therefore 2(y - 4) = 3(x - 9)$$

$$\therefore 2y - \square = \square + 27$$

$$\therefore 3x - 2y + 8 + \square = 0$$

$$\therefore 3x - 2y + 35 = 0$$

**(2):** A rod of 108 meters long is bent to form rectangle. Find its dimensions if the area of rectangle is maximum.

**Solution:** Let  $x$  be the length and  $y$  be breadth of the rectangle.

$$\therefore 2x + 2y = 108$$

$$\therefore x + y = \square$$

$$\therefore y = 54 - \square$$

Now area of the rectangle =  $x y$

$$= x \square$$

$$\therefore f(x) = 54x - \square$$

$$\therefore f'(x) = \square - 2x$$

$$\therefore f'(x) = \square$$

For extreme values,  $f'(x) = 0$

$$\therefore 54 - 2x = 0$$

$$\therefore -2x = \square$$

$$\therefore x = \frac{-54}{-2}$$

$$\therefore x = \square$$

$$\therefore f''(27) = -2 < 0$$

$\therefore$  area is maximum when  $x = 27$ ,  $y = 27$

$\therefore$  The dimensions of rectangles are  $27\text{m} \times 27\text{m}$

**(3):** Find the value of  $x$  for which the function  $f(x) = 2x^3 - 9x^2 + 12x + 2$  is decreasing.

**Solution:** Given  $f(x) = 2x^3 - 9x^2 + 12x + 2$

$$\therefore f'(x) = \square x^2 - \square + \square$$

$$\therefore f'(x) = 6(x - 1) (\square)$$

Now  $f'(x) < 0$

$$\therefore 6(x - 1)(x - 2) < 0$$

since  $ab < 0 \Leftrightarrow a < 0 \ \& \ b > 0$  or  $a > 0$   
&  $b < 0$

Case I]  $(x - 1) < 0$  and  $x - 2 > 0$

$$\therefore x < \square \text{ and } x > \square$$

Which is contradiction

Case II]  $x - 1 > 0$  and  $x - 2 < 0$

$$\therefore x > \square \text{ and } x < \square$$

$$1 < \square < 2$$

$f(x)$  is decreasing if and only if  $x \in (1, 2)$ .





### Let's Study

- Method of Substitution
- Some Special Integrals
- Integration by Parts
- Integration by Partial Fraction



### Let's Recall

- Derivatives



### 5.1.1 Introduction

In this chapter, we shall study the operation which is an inverse process of differentiation. We now want to study the problem : the derivative of a function is given and we have to determine the function. The process of determining such a function is called integration.

#### Consider the following examples:

- (1) Suppose we want to determine a function whose derivative is  $3x^2$ . Since we know that  $\frac{dx^3}{dx} = 3x^2$ . Therefore, the required function is  $f(x) = x^3$ .

$x^3$  is called integral of  $3x^2$  w.r.t.x and this is written as  $\int 3x^2 dx = x^3$ .

The symbol  $\int$ , called the integration sign, was introduced by Leibnitz. ' $dx$ ' indicates that the integration is to be taken with respect to the variable ' $x$ '.

- (2) Suppose we want to determine a function whose derivative is  $\frac{1}{x}$ . Since we know that  $\frac{d}{dx}(\log x) = \frac{1}{x}$ . Therefore, the required

function is  $\log x$ . Using the integral sign, we can write  $\int \left(\frac{1}{x}\right) dx = \log x, x > 0$ .



### Let's Learn

#### 5.1.2 Definition: Integral or primitive or antiderivative of a function.

If  $f(x)$  and  $g(x)$  are two functions such that  $\frac{d}{dx} [f(x)] = g(x)$  then  $f(x)$  is called an integral of  $g(x)$  with respect to  $x$ . It is denoted by  $\int g(x) dx = f(x)$  and read as integral of  $g(x)$  w.r.t.x is  $f(x)$ . Here, we say that  $g(x)$  is the integrand.

This process of finding the integral of a function is called integration. Thus, integration is the inverse operation of differentiation.

For, example,

$$\frac{d}{dx} (x^4) = 4x^3$$

$$\therefore \int 4x^3 dx = x^4$$

But, note that

$$\frac{d}{dx} (x^4 + 5) = 4x^3$$

$$\frac{d}{dx} (x^4 - 8) = 4x^3$$

What is the observation? Can you generalize from the observation?

In general,

$$\frac{d}{dx} (x^4 + c) = 4x^3$$

where,  $c$  is any real number.

Hence, in general, we write

$$\therefore \int 4x^3 dx = x^4 + c$$

The number ' $c$ ' is called constant of integration.

**Note: (i)** From the above discussion, it is clear that integration is an inverse operation of differentiation. Hence integral is also called antiderivative.

(ii) In  $\int f(x)dx$ ,  $f(x)$  is the integrand and  $x$  is the variable of integration.

(iii) 'I' is used to denote an **integral**.

**Integrals of some standard functions.**

1	$\frac{d}{dx} x^n = nx^{n-1}$ $\therefore \int x^n dx = \frac{x^{n+1}}{n+1} + c, n \neq -1$	$\frac{d}{dx} \left[ \frac{(ax+b)^{n+1}}{(n+1)a} \right] = (ax+b)^n$ $\therefore \int (ax+b)^n dx = \frac{(ax+b)^{n+1}}{a(n+1)} + c, \text{ where, } n \neq -1$
2	$\frac{d}{dx} \log x = \frac{1}{x}$ $\therefore \int \left( \frac{1}{x} \right) dx = \log  x  + c$	$\frac{d}{dx} \log(ax+b) = \frac{1}{ax+b} \frac{d}{dx} (ax+b) = \frac{a}{(ax+b)}$ $\therefore \int \left( \frac{1}{ax+b} \right) dx = \frac{\log  ax+b }{a} + c$
3	$\frac{d}{dx} a^x = a^x \log a$ $\therefore \int a^x dx = \frac{a^x}{\log a} + c, a > 0, a \neq 1$	$\frac{d}{dx} a^{px+q} = a^{px+q} (\log a) \frac{d}{dx} (px+q) = a^{px+q} \cdot p \log a$ $\therefore \int a^{px+q} dx = \frac{a^{px+q}}{p \log a} + c, a > 0, a \neq 1$
4	$\frac{d}{dx} e^x = e^x \log e = e^x$ $\therefore \int e^x dx = e^x + c$	$\frac{d}{dx} e^{px+q} = e^{px+q} \frac{d}{dx} (px+q) = e^{px+q} \cdot p$ $\therefore \int e^{px+q} dx = \frac{e^{px+q}}{p} + c$

**Rules of integration:**

**5.1.3 Theorem 1:** If  $f$  is a real valued integrable function of  $x$  and  $k$  is a constant, then

$$\int [k \cdot f(x)] dx = k \int f(x) dx$$

**Theorem 2:** If  $f$  and  $g$  are real valued integrable functions of  $x$ , then

$$\int [f(x) + g(x)] dx = \int f(x) dx + \int g(x) dx$$

**Theorem 3:** If  $f$  and  $g$  are real valued integrable functions of  $x$ , then

$$\int [f(x) - g(x)] dx = \int f(x) dx - \int g(x) dx$$

Generalization of (1), (2) and (3)

**Corollary 1:** If  $f_1, f_2, \dots, f_n$  are real integrable functions of  $x$ , and  $k_1, k_2, \dots, k_n$  are scalar constants then

$$\int [k_1 f_1(x) \pm k_2 f_2(x) \pm \dots \pm k_n f_n(x)] dx$$

$$= k_1 \int f_1(x) dx \pm k_2 \int f_2(x) dx \pm \dots \pm k_n \int f_n(x) dx$$

**Result 1:**

$$\int f(x) dx = F(x) + c \text{ then}$$

$$\int f(ax+b) dx = \frac{F(ax+b)}{a} + c$$

**SOLVED EXAMPLES**

(1) Evaluate  $\int (7x - 2)^2 dx$

**Solution:**  $I = \frac{(7x-2)^{2+1}}{(2+1)7} + c$

$$= \frac{(7x-2)^3}{21} + c$$

(2) Evaluate  $\int \left[ \left( 11 - \frac{t}{3} \right)^7 + (4t+5)^4 \right] dt$

**Solution :**  $I = \int \left( 11 - \frac{t}{3} \right)^7 dt + \int (4t+5)^4 dt$

$$= \frac{\left( 11 - \frac{t}{3} \right)^{7+1}}{7+1} \times (-3) + \frac{(4t+5)^{4+1}}{4+1} \times \frac{1}{4} + c$$

$$= \frac{-3}{8} \left( 11 - \frac{t}{3} \right)^8 + \frac{1}{20} (4t+5)^5 + c$$

(3) Evaluate  $\int \left[ \frac{1}{(6x+5)^4} - \frac{1}{(8-3x)^9} \right] dx$

**Solution :**  $I = \int (6x+5)^{-4} dx - \int (8-3x)^{-9} dx$

$$= \frac{(6x+5)^{-3}}{-3} \times \frac{1}{6} - \left[ \frac{(8-3x)^{-8}}{-8} \right] \times \frac{1}{-3} + c$$

$$= \left( \frac{-1}{18} \right) \frac{1}{(6x+5)^3} - \left( \frac{1}{24} \right) \frac{1}{(8-3x)^8} + c$$

(4) Evaluate  $\int \frac{dx}{\sqrt{x} + \sqrt{x-2}}$

**Solution :**  $I = \int \frac{1}{\sqrt{x} + \sqrt{x-2}} \times \frac{\sqrt{x} - \sqrt{x-2}}{\sqrt{x} - \sqrt{x-2}} dx$

$$= \int \frac{\sqrt{x} - \sqrt{x-2}}{x - (x-2)} dx = \frac{1}{2} \int (\sqrt{x} - \sqrt{x-2}) dx$$

$$= \frac{1}{2} \left[ \int x^{1/2} dx - \int (x-2)^{1/2} dx \right]$$

$$= \frac{1}{2} \left[ \frac{x^{3/2}}{3/2} - \frac{(x-2)^{3/2}}{3/2} \right] + c$$

$$= \frac{1}{3} \left[ x^{3/2} - (x-2)^{3/2} \right] + c$$

(5) Evaluate:  $\int \left( x + \frac{1}{x} \right)^3 dx$

**Solution :**  $I = \int \left( x^3 + \frac{1}{x^3} + 3x + \frac{3}{x} \right) dx$

$$= \frac{x^4}{4} - \frac{1}{2x^2} + \frac{3x^2}{2} + 3 \log|x| + c$$

$$= \frac{x^4}{4} + \frac{3x^2}{2} + 3 \log|x| - \frac{1}{2x^2} + c$$

(6) Evaluate  $\int \frac{1}{x^2} (2x+1)^3 dx$

**Solution :**  $I = \int \frac{(8x^3 + 1 + 12x^2 + 6x)}{x^2} dx$

$$= \int \left( 8x + 12 + \frac{6}{x} + \frac{1}{x^2} \right) dx = 4x^2 + 12x + 6 \log|x| - \frac{1}{x} + c$$

(7) Evaluate  $\int \frac{5(x^6+1)}{x^2+1} dx$

**Solution :**  $I = \int \frac{5(x^2+1)(x^4-x^2+1)}{(x^2+1)} dx$

$$= \int 5(x^4 - x^2 + 1) dx = x^5 - \frac{5}{3} x^3 + 5x + c$$

(8) Evaluate  $\int x^3 \left( 2 - \frac{3}{x} \right)^2 dx$

**Solution :**  $I = \int x^3 \left( 4 - \frac{12}{x} + \frac{9}{x^2} \right) dx$

$$= \int (4x^3 - 12x^2 + 9x) dx$$

$$= 4 \frac{x^4}{4} - 12 \frac{x^3}{3} + 9 \frac{x^2}{2} + c$$

$$= x^4 - 4x^3 + \frac{9}{2} x^2 + c$$

(9) Evaluate  $\int \frac{x^3 + 4x^2 - 6x + 5}{x} dx$

**Solution :**  $I = \int \left( x^2 + 4x - 6 + \frac{5}{x} \right) dx$

$$= \int x^2 dx + 4 \int x dx - 6 \int dx + 5 \int \frac{1}{x} dx$$

$$= \frac{x^3}{3} + 4 \frac{x^2}{2} - 6x + 5 \log|x| + c$$

(10) Evaluate  $\int (e^{a \log x} + e^{x \log a}) dx$

**Solution :**  $I = \int (e^{\log_e x^a} + e^{\log_e a^x}) dx$

$$= \int (x^a + a^x) dx = \frac{x^{a+1}}{a+1} + \frac{a^x}{\log a} + c$$



(11) Evaluate  $\int \left( e^{(1-5t)} + \frac{1}{5t+1} \right) dt$

**Solution:**  $I = \int e^{(1-5t)} dt + \int \left( \frac{1}{5t+1} \right) dt$

$$I = \frac{e^{(1-5t)}}{(-5)} + \left( \frac{\log|5t+1|}{5} \right) + c$$

(12) If  $f'(x) = 8x^3 + 3x^2 - 10x - k$ ,  $f(0) = -3$  and  $f(-1) = 0$ , find  $f(x)$

**Solution:** By the definition of integral

$$f(x) = \int f'(x) dx = \int (8x^3 + 3x^2 - 10x - k) dx$$

$$= 8 \int x^3 dx + 3 \int x^2 dx - 10 \int x dx - k \int dx$$

$$= 8 \frac{x^4}{4} + 3 \frac{x^3}{3} - 10 \frac{x^2}{2} - kx + c$$

$$f(x) = 2x^4 + x^3 - 5x^2 - kx + c$$

Now  $f(0) = -3$  gives  $c = -3$

and  $f(-1) = 0$  gives  $k = 7$

$$f(x) = 2x^4 + x^3 - 5x^2 - 7x - 3$$

### EXERCISE 5.1

(i) Evaluate  $\int \frac{-2}{\sqrt{5x-4} - \sqrt{5x-2}} dx$

(ii) Evaluate  $\int \left( 1 + x + \frac{x^2}{2!} \right) dx$

(iii) Evaluate  $\int \frac{3x^3 - 2\sqrt{x}}{x} dx$

(iv) Evaluate  $\int (3x^2 - 5)^2 dx$

(v) Evaluate  $\int \frac{1}{x(x-1)} dx$

(vi) If  $f'(x) = x^2 + 5$  and  $f(0) = -1$ , then find the value of  $f(x)$ .

(vii) If  $f'(x) = 4x^3 - 3x^2 + 2x + k$ ,  $f(0) = 1$  and  $f(1) = 4$ , find  $f(x)$

(viii) If  $f'(x) = \frac{x^2}{2} - kx + 1$ ,  $f(0) = 2$  and  $f(3) = 5$ , find  $f(x)$

## 5.2 Method of Change of Variable or Method of Substitution

In this method, we reduce the given function to standard form by changing variable  $x$  to  $t$ , using some suitable substitution  $x = \phi(t)$

**Theorem 4 :** If  $x = \phi(t)$  is a differentiable function of  $t$ , then

$$\int f(x) dx = \int f[\phi(t)] \phi'(t) dt$$

### 5.2.1 Corollary 1:

$$\int [f(x)]^n f'(x) dx = \frac{[f(x)]^{n+1}}{(n+1)} + c$$

### SOLVED EXAMPLES

1. Evaluate  $\int \frac{(\log x)^7}{x} dx$

**Solution:** Put  $\log x = t$

$$\therefore \frac{1}{x} dx = dt$$

$$\therefore I = \int t^7 dt = \frac{t^{7+1}}{7+1} + c = \frac{1}{8} (\log x)^8 + c$$

2. Evaluate  $\int \frac{1}{2x + x^{-n}} dx$

**Solution:**  $I = \int \frac{1}{2x + \left( \frac{1}{x^n} \right)} dx$

$$= \int \frac{x^n}{2x^{(n+1)} + 1} dx$$

Put  $x^{(n+1)} = t$

$$\therefore (n+1)x^n dx = dt$$

$$\therefore x^n dx = \frac{dt}{n+1}$$

$$\therefore I = \int \frac{1}{(2t+1)} \times \frac{dt}{(n+1)}$$

$$= \frac{1}{(n+1)} \int \frac{dt}{(2t+1)}$$

$$= \frac{1}{n+1} \frac{\log|2t+1|}{2} + c$$

$$I = \frac{1}{2(n+1)} \log|2x^{n+1} + 1| + c$$

3. Evaluate  $\int \frac{4x-6}{(x^2-3x+5)^{\frac{3}{2}}} dx$

**Solution:**  $I = \int \frac{2(2x-3)}{(x^2-3x+5)^{\frac{3}{2}}} dx$

Put  $(x^2-3x+5) = t$

$\therefore (2x-3)dx = dt$

$I = \int \frac{2dt}{t^{\frac{3}{2}}} = 2 \int t^{\left(\frac{-3}{2}\right)} dt$

$= 2 \left[ \frac{t^{\left(\frac{-1}{2}\right)}}{\left(\frac{-1}{2}\right)} \right] = \frac{-4}{\sqrt{t}} + c$

$I = \frac{-4}{\sqrt{x^2-3x+5}} + c$

4. Evaluate  $\int \frac{(x+1)(x+\log x)^4}{-3x} dx$

**Solution:**  $I = \left(-\frac{1}{3}\right) \int (x+\log x)^4 \left(\frac{x+1}{x}\right) dx$

$= \left(-\frac{1}{3}\right) \int (x+\log x)^4 \left(1+\frac{1}{x}\right) dx$

Put  $x+\log x = t \therefore \left(1+\frac{1}{x}\right) dx = dt$

$= \left(-\frac{1}{3}\right) \int (t)^4 dt = \left(-\frac{1}{3}\right) \frac{t^5}{5} + c$

$= \left(-\frac{1}{15}\right) (x+\log x)^5 + c$

**5.2.2 Corollary 2:**  $\int \left[ \frac{f'(x)}{f(x)} \right] dx = \log f(x) + c$

5. Evaluate  $\int \frac{e^{3x}}{e^{3x}+1} dx$

**Solution:** Put  $e^{3x}+1 = t$

$\therefore 3e^{3x} dx = dt$

$\therefore e^{3x} dx = \frac{dt}{3}$

$I = \int \frac{1}{t} \frac{dt}{3} = \frac{1}{3} \int \frac{1}{t} dt = \frac{1}{3} \log|t| + c$

$= \frac{1}{3} \log|e^{3x}+1| + c$

6. Evaluate  $\int \frac{1}{x(\log x-1)} dx$

**Solution:** Put  $\log x-1 = t$

$\frac{1}{x} dx = dt$

$I = \int \frac{1}{(\log x-1)} \times \frac{1}{x} dx$

$\int \frac{1}{t} dt = \log|t| + c = \log|\log x-1| + c$

7. Evaluate  $\int \frac{e^x+1}{e^x+x} dx = \int \frac{\frac{d}{dx}(e^x+x)}{e^x+x} dx$

$= \log|e^x+x| + c$

8. Evaluate  $\int \frac{e^{x-1}+x^{e-1}}{e^x+x^e} dx$

**Solution:** Put  $e^x+x^e = t$

$\therefore (e^x+ex^{e-1})dx = dt$

$\therefore e(e^{x-1}+x^{e-1})dx = dt$

$\therefore (e^{x-1}+x^{e-1})dx = \frac{dt}{e}$

$I = \int \frac{1}{t} \frac{dt}{e} = \frac{1}{e} \int \frac{1}{t} dt = \frac{1}{e} \log|t| + c$

$= \frac{1}{e} \log|e^x+x^e| + c$

9. Evaluate  $\int \frac{1}{x \log x \cdot \log(\log x)} dx$

**Solution:**  $I = \int \frac{1}{\log(\log x)} \cdot \frac{1}{x \cdot \log x} dx$

Put  $\log(\log x) = t$

$\therefore \frac{1}{\log x} \frac{1}{x} dx = dt$

$\therefore \frac{1}{x \log x} dx = dt$

$$I = \int \frac{1}{t} dt = \log|t| + c$$

$$= \log|\log(\log x)| + c$$

10. Evaluate  $\int \frac{10x^9 + 10^x \cdot \log 10}{10^x + x^{10}} dx$

**Solution:** Put  $10^x + x^{10} = t$

$$\therefore (10^x \cdot \log 10 + 10x^9) dx = dt$$

$$I = \int \frac{1}{t} dt = \log|t| + c$$

$$= \log|10^x + x^{10}| + c$$

11. Evaluate  $\int \frac{1}{1+e^{-x}} dx = \int \frac{1}{1+\frac{1}{e^x}} dx$

**Solution:**  $I = \int \frac{e^x}{e^x + 1} dx = \int \frac{\frac{d}{dx}(e^x + 1)}{e^x + 1} dx$

$$= \log|e^x + 1| + c$$

12. Evaluate  $I = \int \frac{e^{2x} - 1}{e^{2x} + 1} dx$

**Solution:**  $I = \int \frac{e^x(e^x - e^{-x})}{e^x(e^x + e^{-x})} dx$

$$= \int \frac{e^x - e^{-x}}{e^x + e^{-x}} dx = \int \frac{\frac{d}{dx}(e^x + e^{-x})}{e^x + e^{-x}} dx$$

$$I = \log|e^x + e^{-x}| + c$$

**5.2.3 Corollary 3:**  $\int \left[ \frac{f'(x)}{\sqrt{f(x)}} \right] dx = 2\sqrt{f(x)} + c$

**5.2.3 Corollary 4:**

$$\int \left[ \frac{f'(x)}{\sqrt[n]{f(x)}} \right] dx = \frac{n\sqrt[n]{f(x)}^{n-1}}{n-1} + c$$

13. Evaluate :  $\int \frac{x^{n-1}}{\sqrt{1+x^n}} dx$

**Solution:** Put  $x^n = t$

$$\therefore nx^{n-1} dx = dt$$

$$\therefore x^{n-1} dx = dt/n$$

$$I = \int \frac{1}{\sqrt{1+t}} \frac{dt}{n} = \frac{1}{n} \int (1+t)^{-\frac{1}{2}} dt$$

$$= \frac{1}{n} \cdot \frac{(1+t)^{\frac{1}{2}}}{\left(\frac{1}{2}\right)} + c = \frac{2}{n} \sqrt{1+x^n} + c$$

14. Evaluate  $\int \frac{3x^2}{\sqrt{1+x^3}} dx$

**Solution:** Put  $1+x^3 = t$

$$\therefore 3x^2 dx = dt$$

$$I = \int \frac{1}{\sqrt{t}} dt \quad 3x^2 dx = dt$$

$$= 2\sqrt{t} + c = 2\sqrt{1+x^3} + c$$

**Integral of Type:**  $\int (ax+b)\sqrt{cx+d} dx$

15. Evaluate  $\int (2x+1)\sqrt{x-4} dx$

**Solution:** Put  $(x-4) = t$

$$\therefore dx = dt$$

$$x = t + 4$$

$$I = \int [2(t+4)+1]\sqrt{t} dt = \int (2t+9)\sqrt{t} dt$$

$$= \int \left( 2t^{\frac{3}{2}} + 9t^{\frac{1}{2}} \right) dt = 2 \int t^{\frac{3}{2}} dt + 9 \int t^{\frac{1}{2}} dt$$

$$= 2 \frac{t^{\frac{5}{2}}}{\left(\frac{5}{2}\right)} + 9 \frac{t^{\frac{3}{2}}}{\left(\frac{3}{2}\right)} + c = \frac{4}{5}(x-4)^{\frac{5}{2}} + 6(x-4)^{\frac{3}{2}} + c$$

16. Evaluate  $\int (5-3x)(2-3x)^{-\frac{1}{2}} dx$

**Solution:** Put  $2 - 3x = t$

$$\therefore -3 dx = dt$$

$$dx = -dt / 3 \text{ Also } x = (2 - t)/3$$

$$I = \int \left[ 5 - 3 \left( \frac{2-t}{3} \right) \right] (t)^{\left(\frac{-1}{2}\right)} \left( \frac{-dt}{3} \right)$$

$$= \frac{-1}{3} \int (5 - 2 + t)(t)^{\left(\frac{-1}{2}\right)} dt$$

$$= \frac{-1}{3} \int (3 + t)(t)^{\left(\frac{-1}{2}\right)} dt$$

$$= \frac{-1}{3} \int \left( 3(t)^{\left(\frac{-1}{2}\right)} + (t)^{\left(\frac{1}{2}\right)} \right) dt$$

$$= \frac{-3}{3} \int t^{\left(\frac{-1}{2}\right)} dt - \frac{1}{3} \int t^{\left(\frac{1}{2}\right)} dt$$

$$= \frac{t^{\frac{1}{2}}}{\left(\frac{1}{2}\right)} - \frac{1}{3} \frac{t^{\frac{3}{2}}}{\left(\frac{3}{2}\right)} + c$$

$$= -2\sqrt{2-3x}$$

$$- \frac{2}{9} (2-3x)^{\frac{3}{2}} + c$$

17. Evaluate  $\int \frac{5x^2 + 4x + 7}{(2x+3)^{\frac{3}{2}}} dx$

**Solution:** Put  $2x + 3 = t$

$$\therefore 2 dx = dt$$

$$\therefore dx = \frac{dt}{2}$$

$$\text{Also } x = \frac{(t-3)}{2}$$

$$I = \int \frac{5 \left( \frac{t-3}{2} \right)^2 + 4 \left( \frac{t-3}{2} \right) + 7}{t^{\left(\frac{3}{2}\right)}} \frac{dt}{2}$$

$$= \frac{1}{2} \int \frac{5 \left( \frac{t^2 - 6t + 9}{4} \right) + 2(t-3) + 7}{t^{\left(\frac{3}{2}\right)}} dt$$

$$= \frac{1}{2} \int \frac{5t^2 - 30t + 45 + 8t - 24 + 28}{4t^{\left(\frac{3}{2}\right)}} dt$$

$$= \frac{1}{8} \int \frac{5t^2 - 22t + 49}{t^{\left(\frac{3}{2}\right)}} dt$$

$$= \frac{1}{8} \int \left( 5t^{\left(\frac{1}{2}\right)} - 22t^{\left(\frac{-1}{2}\right)} + 49t^{\left(\frac{-3}{2}\right)} \right) dt$$

$$= \frac{5}{8} \int t^{\left(\frac{1}{2}\right)} dt - \frac{22}{8} \int t^{\left(\frac{-1}{2}\right)} dt + \frac{49}{8} \int t^{\left(\frac{-3}{2}\right)} dt$$

$$= \frac{5}{8} t^{\left(\frac{3}{2}\right)} - \frac{11}{4} t^{\left(\frac{1}{2}\right)} + \frac{49}{4} t^{\left(\frac{-1}{2}\right)} + c$$

$$= \frac{5}{12} (2x+3)^{3/2} - \frac{11}{2} (2x+3)^{1/2}$$

$$- \int \frac{49}{2} (2x+3)^{-1/2} + c$$

18. Evaluate  $\int \frac{x^7}{(1+x^4)^2} dx$

**Solution:** Let,  $I = \int \frac{x^7}{(1+x^4)^2} dx = \int \frac{x^4 x^3}{(1+x^4)^2} dx$

$$\text{Put } 1+x^4 = t$$

$$\therefore 4x^3 dx = dt$$

$$\therefore x^3 dx = \frac{dt}{4}$$

$$\text{Also } x^4 = t - 1$$

$$I = \int \frac{t-1}{(t)^2} \frac{dt}{4} = \frac{1}{4} \int \left( \frac{1}{t} - \frac{1}{t^2} \right) dt$$

$$= \frac{1}{4} \int \left( \frac{1}{t} \right) dt - \frac{1}{4} \int \left( \frac{1}{t^2} \right) dt = \frac{1}{4} \int \left( \frac{1}{t} \right) dt - \frac{1}{4} \int (t^{-2}) dt$$

$$= \frac{1}{4} \log|t| - \frac{1}{4} \cdot \frac{t^{-1}}{-1} + c = \frac{1}{4} \log|t| + \frac{1}{4} \frac{1}{t} + c$$

$$= \frac{1}{4} \log|1+x^4| + \frac{1}{4} \frac{1}{1+x^4} + c$$

## EXERCISE 5.2

Evaluate the following.

(i)  $\int x\sqrt{1+x^2} dx$

(ii)  $\int \frac{x^3}{\sqrt{1+x^4}} dx$

(iii)  $\int (e^x + e^{-x})^2 (e^x - e^{-x}) dx$

(iv)  $\int \frac{1+x}{x+e^{-x}} dx$

(v)  $\int (x+1)(x+2)^7(x+3) dx$

(vi)  $\int \frac{1}{x \log x} dx$

(vii)  $\int \frac{x^5}{x^2+1} dx$

(viii)  $\int \frac{2x+6}{\sqrt{x^2+6x+3}} dx$

(ix)  $\int \frac{1}{\sqrt{x+x}} dx$

(x)  $\int \frac{1}{x(x^6+1)} dx$

### Activities

For each of these integrals, determine a strategy for evaluating. Don't evaluate them, just figure out which technique of integration will work, including what substitutions you will use.

1)  $\int \frac{1}{x \log x} dx$       2)  $\int \frac{3}{x^2+5x+4} dx$

3)  $\int \frac{x+5}{\sqrt{x^2+5x+7}} dx$       4)  $\int \frac{e^x}{36-e^{2x}} dx$

**5.3 Integrals of the form**  $\int \frac{ae^x+b}{ce^x+d} dx$   
where  $a, b, c, d \in R$

## SOLVED EXAMPLES

(1) Evaluate  $\int \frac{4e^x - 25}{2e^x - 5} dx$

Put Numerator = A (Denominator + B  
( $\frac{d}{dx}$  Denominator))

$$4e^x - 25 = A(2e^x - 5) + B \left[ \frac{d}{dx} (2e^x - 5) \right]$$

$$= A(2e^x - 5) + B(2e^x)$$

$$= (2A + 2B)e^x - 5A$$

Comparing the coefficients of  $e^x$  and constant term on both sides, we get

$$2A + 2B = 4 \quad \& \quad -25 = -5A$$

$$\therefore A = 5 \text{ and } B = -3$$

$$\therefore 4e^x - 25 = 5(2e^x - 5) - 3(2e^x)$$

$$\therefore I = \int \frac{5(2e^x - 5) - 3(2e^x)}{2e^x - 5} dx$$

$$= \int \left[ 5 - \frac{3(2e^x)}{2e^x - 5} \right] dx$$

$$= 5 \int dx - 3 \int \frac{2e^x}{2e^x - 5} dx$$

$$= 5x - 3 \log |2e^x - 5| + c$$

## EXERCISE 5.3

Evaluate the following.

1)  $\int \frac{3e^{2t} + 5}{4e^{2t} - 5} dt$

2)  $\int \frac{20 - 12e^x}{3e^x - 4} dx$

3)  $\int \frac{3e^x + 4}{2e^x - 8} dt$

4)  $\int \frac{2e^x + 5}{2e^x + 1} dt$

### 5.4.1 Results

$$1. \int \frac{1}{x^2 - a^2} dx = \frac{1}{2a} \log \left| \frac{x-a}{x+a} \right| + c$$

$$2. \int \frac{1}{a^2 - x^2} dx = \frac{1}{2a} \log \left| \frac{a+x}{a-x} \right| + c$$

$$3. \int \frac{1}{\sqrt{x^2 + a^2}} dx = \log \left| x + \sqrt{x^2 + a^2} \right| + c$$

$$4. \int \frac{1}{\sqrt{x^2 - a^2}} dx = \log \left| x + \sqrt{x^2 - a^2} \right| + c$$

#### SOLVED EXAMPLES

Evaluate the following.

$$1. \int \frac{1}{9x^2 - 4} dx$$

$$\text{Solution: } I = \frac{1}{9} \int \frac{1}{x^2 - \left(\frac{2}{3}\right)^2} dx$$

$$= \left(\frac{1}{9}\right) \frac{1}{2\left(\frac{2}{3}\right)} \log \left| \frac{x - \frac{2}{3}}{x + \frac{2}{3}} \right| + c$$

$$= \frac{1}{12} \log \left| \frac{3x-2}{3x+2} \right| + c$$

$$2. \int \frac{1}{16-9x^2} dx$$

$$\text{Solution: } I = \frac{1}{9} \int \frac{1}{\frac{16}{9} - x^2} dx$$

$$= \frac{1}{9} \int \frac{1}{\left(\frac{4}{3}\right)^2 - x^2} dx$$

$$= \left(\frac{1}{9}\right) \frac{1}{2\left(\frac{4}{3}\right)} \log \left| \frac{\frac{4}{3} + x}{\frac{4}{3} - x} \right| + c$$

$$= \frac{1}{24} \log \left| \frac{4+3x}{4-3x} \right| + c$$

$$3. \int \frac{1}{\sqrt{9x^2 + 25}} dx$$

$$\text{Solution: } I = \frac{1}{3} \int \frac{1}{\sqrt{x^2 + \frac{25}{9}}} dx$$

$$= \frac{1}{3} \int \frac{1}{\sqrt{x^2 + \left(\frac{5}{3}\right)^2}} dx$$

$$= \frac{1}{3} \log \left| x + \sqrt{x^2 + \left(\frac{5}{3}\right)^2} \right| + c$$

$$4. \int \frac{1}{\sqrt{4x^2 - 9}} dx$$

$$\text{Solution: } I = \frac{1}{2} \int \frac{1}{\sqrt{x^2 - \frac{9}{4}}} dx$$

$$= \frac{1}{2} \int \frac{1}{\sqrt{x^2 - \left(\frac{3}{2}\right)^2}} dx$$

$$= \frac{1}{2} \log \left| x + \sqrt{x^2 - \left(\frac{3}{2}\right)^2} \right| + c$$

$$5. \int \frac{1}{x\sqrt{(\log x)^2 - 5}} dx$$

$$\text{Solution: } \text{Put } \log x = t \quad \therefore \frac{1}{x} dx = dt$$

$$\therefore I = \int \frac{1}{\sqrt{t^2 - (\sqrt{5})^2}} dt$$

$$= \log \left| t + \sqrt{t^2 - (\sqrt{5})^2} \right| + c$$

$$= \log \left| \log x + \sqrt{(\log x)^2 - (\sqrt{5})^2} \right| + c$$

**5.4.2 Integrals of the form  $\int \frac{P(x)}{Q(x)} dx$  where degree (P(x))  $\geq$  degree (Q(x)).**

**Method:** To evaluate  $\int \frac{P(x)}{Q(x)} dx$

1. Divide  $P(x)$  by  $Q(x)$ .

After dividing  $P(x)$  by  $Q(x)$  we get quotient  $q(x)$  and remainder  $r(x)$ .

2. Use Dividend = quotient  $\times$  divisor + remainder

$$P(x) = q(x) \times Q(x) + r(x)$$

$$\frac{P(x)}{Q(x)} = q(x) + \frac{r(x)}{Q(x)}$$

$$\int \frac{P(x)}{Q(x)} dx = \int q(x) dx + \int \frac{r(x)}{Q(x)} dx$$

3. Using standard integrals, evaluate I.

**SOLVED EXAMPLES**

1. Evaluate  $I = \int \frac{x^3 + x + 1}{x^2 - 1} dx$

**Solution:**  $I = \int \frac{x^3 + x + 1}{x^2 - 1} dx$   
 $x = Q$

$$D = x^2 - 1 \Big) \begin{array}{r} x^3 + x + 1 \\ - x^3 - x \\ \hline + 2x + 1 = R \end{array}$$

$$\therefore I = \int \left( Q + \frac{R}{D} \right) dx$$

$$\begin{aligned} I &= \int \left[ x + \frac{2x+1}{x^2-1} \right] dx \\ &= \int x dx + \int \frac{2x}{x^2-1} dx + \int \frac{1}{x^2-1} dx \\ &= \frac{x^2}{2} + \log|x^2-1| + \int \frac{1}{x^2-1^2} dx + c \\ &= \frac{x^2}{2} + \log|x^2-1| + \frac{1}{2} \log \left| \frac{x-1}{x+1} \right| + c \end{aligned}$$

**5.4.3 Integrals of the type  $\int \frac{1}{ax^2 + bx + c} dx$**

In order to find this type of integrals we may use the following steps :

Step 1 : Make the coefficient of  $x^2$  as one if

it is not, then  $\frac{1}{a} \int \frac{1}{x^2 + \frac{b}{a}x + \frac{c}{a}} dx$

Step 2: Add and subtract the square of the

half of coefficient of  $x$  that is  $\left(\frac{b}{2a}\right)^2$  to complete

the square  $\frac{1}{a} \int \frac{1}{x^2 + \frac{b}{a}x + \left(\frac{b}{2a}\right)^2 - \left(\frac{b}{2a}\right)^2 + \frac{c}{a}} dx =$

$$\frac{1}{a} \int \frac{1}{\left(x + \frac{b}{2a}\right)^2 + \left(\frac{4ac - b^2}{4a^2}\right)} dx$$

**SOLVED EXAMPLES**

Evaluate the following.

1.  $\int \frac{1}{2x^2 + x - 1} dx$

**Solution:**  $I = \frac{1}{2} \int \frac{1}{x^2 + \frac{1}{2}x - \frac{1}{2}} dx$

$$= \frac{1}{2} \int \frac{1}{x^2 + \frac{1}{2}x + \frac{1}{16} - \frac{1}{16} - \frac{1}{2}} dx$$

$$= \frac{1}{2} \int \frac{1}{\left(x + \frac{1}{4}\right)^2 - \left(\frac{3}{4}\right)^2} dx$$

$$= \frac{1}{2} \left[ \frac{1}{2\left(\frac{3}{4}\right)} \right] \log \left| \frac{\left(x + \frac{1}{4}\right) - \frac{3}{4}}{\left(x + \frac{1}{4}\right) + \frac{3}{4}} \right| + c$$

$$= \frac{1}{3} \log \left| \frac{x - \frac{1}{2}}{x + 1} \right| + c$$

$$\frac{1}{3} \log \left| \frac{2x-1}{2(x+1)} \right| + c$$

2.  $\int \frac{1}{1+x-x^2} dx$

**Solution:**  $I = \int \frac{1}{1 + \frac{1}{4} - \frac{1}{4} + x - x^2} dx$

$$= \int \frac{1}{\left(1 + \frac{1}{4}\right) - \left(x^2 - x + \frac{1}{4}\right)} dx$$

$$= \int \frac{1}{\left(\frac{\sqrt{5}}{2}\right)^2 - \left(x - \frac{1}{2}\right)^2} dx$$

$$= \frac{1}{2 \left(\frac{\sqrt{5}}{2}\right)} \log \left| \frac{\frac{\sqrt{5}}{2} + \left(x - \frac{1}{2}\right)}{\frac{\sqrt{5}}{2} - \left(x - \frac{1}{2}\right)} \right| + c$$

$$= \frac{1}{\sqrt{5}} \log \left| \frac{\sqrt{5} - 1 + 2x}{\sqrt{5} + 1 - 2x} \right| + c$$

3.  $\int \frac{e^x}{e^{2x} + 6e^x + 5} dx$

**Solution:** Put  $e^x = t$

$$\therefore e^x dx = dt$$

$$I = \int \frac{dt}{t^2 + 6t + 5}$$

$$= \int \frac{dt}{t^2 + 6t + 9 - 9 + 5}$$

$$= \int \frac{dt}{(t+3)^2 - 2^2}$$

$$= \frac{1}{2(2)} \log \left| \frac{(t+3) - 2}{(t+3) + 2} \right| + c$$

$$= \frac{1}{4} \log \left| \frac{e^x + 1}{e^x + 5} \right| + c$$

4.  $\int \frac{1}{\sqrt{(x-2)(x-3)}} dx$

**Solution:**  $I = \int \frac{1}{\sqrt{x^2 - 5x + 6}} dx$

$$= \int \frac{1}{\sqrt{x^2 - 5x + \frac{25}{4} - \frac{25}{4} + 6}} dx$$

$$= \int \frac{1}{\sqrt{\left(x - \frac{5}{2}\right)^2 - \left(\frac{1}{2}\right)^2}} dx$$

$$= \log \left| \left(x - \frac{5}{2}\right) + \sqrt{\left(x - \frac{5}{2}\right)^2 - \left(\frac{1}{2}\right)^2} \right| + c$$

5.  $\int \frac{2x+1}{\sqrt{x^2+2x+3}} dx$

**Solution:**  $I = \int \frac{(2x+2) - 1}{\sqrt{x^2+2x+3}} dx$

$$= \int \frac{2x+2}{\sqrt{x^2+2x+3}} dx - \int \frac{dx}{\sqrt{x^2+2x+3}}$$

$$= 2\sqrt{x^2+2x+3} - \log \left| \frac{1}{\sqrt{(x^2+2x+1)+2}} \right|$$

$$= 2\sqrt{x^2+2x+3} - \log \left| (x+1) + \sqrt{x^2+2x+3} \right| + c$$

6.  $\int \frac{x+1}{\sqrt{x^2+3x+2}} dx$

**Solution:**  $x+1 = A \frac{d}{dx}(x^2+3x+2) + B$

$$x+1 = A(2x+3) + B = 2Ax + 3A + B$$

$$\therefore 2A = 1 \text{ and } 3A + B = 1 \text{ Solving we get}$$

$$A = \frac{1}{2} \text{ and } B = \frac{-1}{2}$$

$$\therefore I = \int \frac{\frac{1}{2}(2x+3) - \frac{1}{2}}{\sqrt{x^2+3x+2}} dx$$



$$= \frac{1}{2} \int \frac{2x+3}{\sqrt{x^2+3x+2}} dx - \frac{1}{2} \int \frac{dx}{\sqrt{x^2+3x+2}}$$

$$= \frac{2}{2} \sqrt{x^2+3x+2} - \frac{1}{2} \int \frac{1}{\sqrt{\left(x+\frac{3}{2}\right)^2 - \left(\frac{1}{2}\right)^2}} dx$$

$$= \sqrt{x^2+3x+2} - \frac{1}{2} \log \left| \left(x+\frac{3}{2}\right) + \sqrt{x^2+3x+2} \right| + c$$

$$= \log \left| t + \sqrt{t^2 - (\sqrt{5})^2} \right| + c$$

$$= \log \left| \log x + \sqrt{(\log x)^2 - 5} \right| + c$$

$$2. \int \frac{x^2 dx}{\sqrt{x^6 + 2x^3 + 3}}$$

**Solution:** Put  $x^3 = t$

$$3x^2 dx = dt : x^2 dx = \frac{dt}{3}$$

$$I = \int \frac{1}{\sqrt{t^2 + 2t + 3}} \frac{dt}{3}$$

$$= \frac{1}{3} \int \frac{1}{\sqrt{t^2 + 2t + 1 + 2}}$$

$$= \frac{1}{3} \log \left| (t+1) + \sqrt{t^2 + 2t + 3} \right|$$

$$= \frac{1}{3} \log \left| (t+1) + \sqrt{t^2 + 2t + 3} \right| + c$$

$$= \frac{1}{3} \log \left| (x^3 + 1) + \sqrt{x^6 + 2x^3 + 3} \right| + c$$

#### 5.4.4 Integrals reducible to the form

$$\int \frac{1}{\sqrt{ax^2 + bx + c}} dx$$

To find this type of integrals we use the following steps:

Step 1: Make the coefficients of  $x^2$  as one

if it is not, ie  $\frac{1}{\sqrt{a}} \int \frac{dx}{\sqrt{x^2 + \frac{bx}{a} + \frac{c}{a}}}$ .

Step 2: Find half of the coefficient of  $x$ .

Step 3: Add and subtract  $\left(\frac{1}{2} \text{coeff. of } x\right)^2$  inside the square root so that the square root is in the form

$$\left(x + \frac{b}{2a}\right)^2 + \frac{4ac - b^2}{4a^2} \text{ or } \frac{4ac - b^2}{4a^2} - \left(x + \frac{b}{2a}\right)^2$$

Step 4: Use the suitable standard form for evaluation.

#### 5.4.5 Integrals of the form $\int \frac{px+q}{\sqrt{ax^2+bx+c}} dx$

To find this type of integrals we use the following steps:

Step 1: Write the numerator  $px + q$  in the following form

$$px + q = A \frac{d}{dx}(ax^2 + bx + c) + B$$

Step 2: Obtain the values of A and B by equating the coefficients of same power of  $x$  on both sides.

Step 3: Replace  $px + q$  by  $A(2ax + b) + B$  in the given integral to get in the form of

$$\int \frac{px+q}{\sqrt{ax^2+bx+c}} dx$$

$$= A \int \frac{2ax+b}{\sqrt{ax^2+bx+c}} dx + B \int \frac{1}{\sqrt{ax^2+bx+c}} dx$$

$$= 2A \sqrt{|ax^2+bx+c|} + B \int \frac{dx}{\sqrt{ax^2+bx+c}}$$

#### SOLVED EXAMPLES

$$1. \int \frac{dx}{x\sqrt{(\log x)^2 - 5}}$$

**Solution :** Put  $\log x = t$

$$\therefore \frac{dx}{x} = dt$$

$$I = \int \frac{1}{\sqrt{t^2 - 5}} dt$$

$$= \int \frac{1}{\sqrt{t^2 - (\sqrt{5})^2}} dt$$

## SOLVED EXAMPLES

1.  $\int \frac{2x+8}{\sqrt{x^2+6x+13}} dx$

Let  $2x+8 = A \frac{d}{dx}(x^2+6x+13) + B$

$2x+8 = A(2x+6) + B$

$\therefore A = 1, B = 2$

$= \int \frac{2x+6}{\sqrt{x^2+6x+13}} dx + \int \frac{2}{\sqrt{x^2+6x+13}} dx$

$= \sqrt{x^2+6x+13} + 2 \log \left| (x+3) + \sqrt{x^2+6x+13} \right| + c$

(using  $\int \frac{f'(x)}{f(x)} dx = \sqrt[2]{f(x)} + c$  in the 1<sup>st</sup> integral)

2.  $\int \sqrt{\frac{x+1}{x+2}} dx$

**Solution:**  $I = \int \sqrt{\frac{(x+1)(x+1)}{(x+2)(x+1)}} dx$

$= \int \frac{x+1}{\sqrt{x^2+3x+2}} dx$

Let  $x+1 = A \frac{d}{dx}(x^2+3x+2) + B$

$= A(2x+3) + B$

Comparing the coefficient of  $x$ , we get

$1 = 2A$  and  $1 = 3A + B$

$A = \frac{1}{2}$  and  $B = \frac{-1}{2}$

$= \int \frac{x+1}{\sqrt{x^2+3x+2}} dx = \int \frac{\frac{1}{2}(2x+3) - \frac{1}{2}}{\sqrt{x^2+3x+2}} dx$

$= \int \frac{\frac{1}{2}(2x+3)}{\sqrt{x^2+3x+2}} dx - \int \frac{\frac{1}{2}}{\sqrt{x^2+3x+2}} dx$

$= \frac{1}{2} 2\sqrt{x^2+3x+2} - \frac{1}{2} \log$

$\left| \left( x + \frac{3}{2} \right) + \sqrt{\left( x + \frac{3}{2} \right)^2 - \left( \frac{1}{2} \right)^2} \right| + c$

$= \frac{1}{2} \int \frac{(2x+3)}{\sqrt{x^2+3x+2}} dx - \int \frac{\frac{1}{2}}{\sqrt{\left( x + \frac{3}{2} \right)^2 - \left( \frac{1}{2} \right)^2}} dx$

$= \sqrt{x^2+3x+2} - \frac{1}{2} \log \left| \left( x + \frac{3}{2} \right) + \sqrt{x^2+3x+2} \right| + c$

3.  $\int \frac{2x+1}{\sqrt{x^2+2x+1}} dx$

**Solution:** Let  $2x+1 = A \frac{d}{dx}(x^2+2x+1) + B$

$= A(2x+2) + B$

$2x+1 = 2Ax + (2A+B)$

Comparing the coefficient of  $x$ , we get

$2 = 2A$  and  $1 = 2A + B$

$A = 1$  and  $B = -1$

$I = \int \frac{(2x+2) - 1}{\sqrt{x^2+2x+1}} dx$

$= \int \frac{(2x+2)}{\sqrt{x^2+2x+1}} dx - \int \frac{1}{\sqrt{x^2+2x+1}} dx$

$\int \frac{(2x+2)}{\sqrt{x^2+2x+1}} dx - \int \frac{1}{\sqrt{(x+1)^2}} dx$

$= 2\sqrt{x^2+2x+1} - \log|x+1| + c$

4.  $\int \sqrt{\frac{1+x}{x}} dx$

**Solution:**  $I = \int \sqrt{\frac{(1+x)(1+x)}{x(1+x)}} dx$

$$= \int \frac{(1+x)}{\sqrt{x^2+x}} dx$$

$$\text{Let } x+1 = A \frac{d}{dx}(x^2+x) + B$$

$$x+1 = A(2x+1) + B = 2Ax + (A+B)$$

Comparing the coefficient of  $x$ , we get

$$1 = 2A \quad \text{and} \quad 1 = A+B$$

$$A = \frac{1}{2} \quad \text{and} \quad B = \frac{1}{2}$$

$$\int \frac{x+1}{\sqrt{x^2+x}} dx = \int \frac{\frac{1}{2}(2x+1) + \frac{1}{2}}{\sqrt{x^2+x}} dx$$

$$= \int \frac{\frac{1}{2}(2x+1)}{\sqrt{x^2+x}} dx + \int \frac{\frac{1}{2}}{\sqrt{x^2+x}} dx$$

$$= \frac{1}{2} \int \frac{(2x+1)}{\sqrt{x^2+x}} dx + \int \frac{\frac{1}{2}}{\sqrt{\left(x+\frac{1}{2}\right)^2 - \left(\frac{1}{2}\right)^2}} dx$$

$$= \frac{1}{2} 2\sqrt{x^2+x} + \frac{1}{2} \log \left| \left(x+\frac{1}{2}\right) + \sqrt{\left(x+\frac{1}{2}\right)^2 - \left(\frac{1}{2}\right)^2} \right| + c$$

$$= \sqrt{x^2+x} + \frac{1}{2} \log \left| \left(x+\frac{1}{2}\right) + \sqrt{x^2+x} \right| + c$$

### EXERCISE 5.4

Evaluate the following.

$$1) \int \frac{1}{4x^2-1} dx$$

$$2) \int \frac{1}{x^2+4x-5} dx$$

$$3) \int \frac{1}{4x^2-20x+17} dx$$

$$4) \int \frac{x}{4x^4-20x^2-3} dx$$

$$5) \int \frac{x^3}{16x^8-25} dx$$

$$6) \int \frac{1}{a^2-b^2x^2} dx$$

$$7) \int \frac{1}{7+6x-x^2} dx$$

$$8) \int \frac{1}{\sqrt{3x^2+8}} dx$$

$$9) \int \frac{1}{\sqrt{x^2+4x+29}} dx$$

$$10) \int \frac{1}{\sqrt{3x^2-5}} dx$$

$$11) \int \frac{1}{\sqrt{x^2-8x-20}} dx$$

## 5.5 Integration by Parts.

**5.5.1 Theorem 5:** If  $u$  and  $v$  are two functions of  $x$  then

$$\int u \cdot v dx = u \int v dx - \int \left[ \int v dx \cdot \frac{du}{dx} \right] dx$$

The method of integration by parts is used when the integrand is expressed as a product of two functions, one of which can be differentiated and the other can be integrated conveniently.

Note:

- (1) When the integrand is a product of two functions, out of which the second has to be integrated (whose integral is known), hence we should make proper choices of first function and second function.
- (2) We can also choose the first function as the function which comes first in the word 'LAE' where

**L - Logarithmic Function**

**A - The Algebraic Function**

**E - The Exponential Function**

## SOLVED EXAMPLES

1.  $\int x e^{-2x} dx$

**Solution:**  $I = x \int e^{-2x} dx - \int \left[ \frac{d}{dx}(x) \int e^{-2x} dx \right] dx$

$$= x \frac{e^{-2x}}{-2} - \int 1 \cdot \frac{e^{-2x}}{-2} dx + c$$

$$= \frac{-1}{2} x e^{-2x} - \frac{1}{4} e^{-2x} + c$$

2.  $\int \log x dx$

**Solution:**  $I = \int (\log x) \cdot 1 dx$

$$= (\log x) \int 1 dx - \int \left[ \frac{d}{dx}(\log x) \int 1 dx \right] dx$$

$$= x \log x - \int \frac{1}{x} x dx + c$$

$$= x \log x - \int dx + c$$

$$= x(\log x - 1) + c$$

3.  $\int x^3 \log x dx$

**Solution:**  $I = \int (\log x) x^3 dx$

$$= (\log x) \int x^3 dx - \int \left[ \frac{d}{dx}(\log x) \int x^3 dx \right] dx$$

$$= \frac{x^4 \log x}{4} - \frac{1}{4} \int x^3 dx + c$$

$$= \frac{x^4 \log x}{4} - \frac{1}{4} \frac{x^4}{4} + c$$

$$= \frac{x^4 \log x}{4} - \frac{x^4}{16} + c$$

4.  $\int \frac{\log(\log x)}{x} dx = \int \log(\log x) \frac{1}{x} dx$

**Solution:** Put  $\log x = t$

$$\therefore \frac{1}{x} dx = dt$$

$$I = \int \log t dt$$

$$= \int (\log t) \cdot 1 dt$$

$$= (\log t) \int 1 dt - \int \left[ \frac{d}{dt}(\log t) \int 1 dt \right] dt$$

$$= t \log t - \int \frac{1}{t} t dt + c$$

$$= t \log t - \int dt + c$$

$$= t(\log t - 1) + c$$

$$= (\log x) \cdot (\log(\log x) - 1) + c$$

5.  $\int x \cdot 2^{-3x} dx$

**Solution:**  $I = x \int (2^{-3x}) dx - \int \left[ \frac{d}{dx} x \int (2^{-3x}) dx \right] dx$

$$= \frac{x(2^{-3x})}{-3(\log 2)} - \int \frac{(2^{-3x})}{-3(\log 2)} dx + c$$

$$= \frac{x(2^{-3x})}{-3(\log 2)} - \frac{1}{-3(\log 2)} \int (2^{-3x}) dx + c$$

$$= \frac{x(2^{-3x})}{-3(\log 2)} - \frac{1}{-3(\log 2)} \left( \frac{2^{-3x}}{-3(\log 2)} \right) + c$$

$$= \frac{-x 2^{-3x}}{3(\log 2)} - \frac{1}{9(\log 2)^2} 2^{-3x} + c$$

**Integral of the type**  $\int e^x \{f(x) + f'(x)\} dx$

These integrals are evaluated by using

$$\int e^x \{f(x) + f'(x)\} dx = e^x f(x) + c$$

1.  $\int e^x \left( \frac{x \log x + 1}{x} \right) dx$

**Solution:**  $I = \int e^x \left( \log x + \frac{1}{x} \right) dx$

Put  $\log x = f(x)$   $f'(x) = \frac{1}{x}$

$$\int e^x \{f(x) + f'(x)\} dx = e^x f(x) + c$$

$$= e^x \log x + c$$

2.  $\int e^x \frac{(1+x^2)}{(1+x)^2} dx$

**Solution:**  $I = \int e^x \frac{(x^2 - 1) + 2}{(1+x)^2} dx$

$$= \int e^x \left[ \frac{x-1}{x+1} + \frac{2}{(x+1)^2} \right] dx$$

Put  $f(x) = \frac{x-1}{x+1}$

$$f'(x) = \frac{2}{(x+1)^2}$$

$$\int e^x \{f(x) + f'(x)\} dx = e^x f(x) + c$$

$$= e^x \left( \frac{x-1}{x+1} \right) + c$$

3.  $\int e^x \frac{(x+3)}{(x+4)^2} dx$

**Solution:**  $I = \int e^x \frac{(x+4-1)}{(x+4)^2} dx$

$$= \int e^x \left[ \frac{1}{x+4} - \frac{1}{(x+4)^2} \right] dx$$

Put  $f(x) = \frac{1}{x+4}$  and  $f'(x) = -\frac{1}{(x+4)^2}$

$$\int e^x \{f(x) + f'(x)\} dx = e^x f(x) + c$$

$$= e^x \frac{1}{x+4} + c$$

**Integrals of the type**  $\int \sqrt{x^2 + a^2} dx, \int \sqrt{x^2 - a^2} dx$

$$\int \sqrt{a^2 + x^2} dx = \frac{x}{2} \sqrt{a^2 + x^2} + \frac{a^2}{2} \log \left| x + \sqrt{a^2 + x^2} \right| + c$$

$$\int \sqrt{x^2 - a^2} dx = \frac{x}{2} \sqrt{x^2 - a^2} - \frac{a^2}{2} \log \left| x + \sqrt{x^2 - a^2} \right| + c$$

In order to evaluate integrals of form  $\int \sqrt{ax^2 + bx + c} dx$  we use the following steps.

Step 1: Make the coefficients of  $x^2$  as one by taking a common.

Step 2: Add and subtract  $\left(\frac{b}{2a}\right)^2$  in  $x^2 + \frac{b}{a}x + \frac{c}{a}$  to get the perfect square

$$\therefore \left(x + \frac{b}{2a}\right)^2 + \frac{4ac - b^2}{4a^2}$$

After applying these two steps the integrals reduces to one of the following two forms

$\int \sqrt{a^2 + x^2} dx, \int \sqrt{x^2 - a^2} dx$  which can be evaluated easily.

### SOLVED EXAMPLES

1.  $\int \sqrt{4x^2 + 5} dx$

**Solution:**  $I = \int 2\sqrt{x^2 + \frac{5}{4}} dx$

$$= 2 \int \sqrt{x^2 + \left(\frac{\sqrt{5}}{2}\right)^2} dx$$

$$= 2 \left[ \frac{x}{2} \sqrt{x^2 + \frac{5}{4}} + \frac{5/4}{2} \log \left| x + \sqrt{x^2 + \frac{5}{4}} \right| \right] + c_1$$

$$= \frac{x}{2} \sqrt{4x^2 + 5} + \frac{5}{4} \log \left| 2x + \sqrt{4x^2 + 5} \right| + c$$

2.  $\int \sqrt{9x^2 - 4} dx$

**Solution:**  $I = \int 3\sqrt{x^2 - \frac{4}{9}} dx$

$$= 3 \int \sqrt{x^2 - \left(\frac{2}{3}\right)^2} dx$$

$$= 3 \left[ \frac{x}{2} \sqrt{x^2 - \frac{4}{9}} - \frac{4/9}{2} \log \left| x + \sqrt{x^2 - \frac{4}{9}} \right| \right] + c_1$$

$$= \frac{x}{2} \sqrt{9x^2 - 4} - \frac{2}{3} \log \left| 3x + \sqrt{9x^2 - 4} \right| + c$$

3.  $\int \sqrt{x^2 - 4x - 5} dx$

**Solution:**  $I = \int \sqrt{(x^2 - 4x + 4) - 9} dx$

$$= \int \sqrt{(x-2)^2 - 3^2} dx$$

$$= \frac{x-2}{2} \sqrt{x^2 - 4x - 5}$$

$$- \frac{9}{2} \log \left| (x-2) + \sqrt{x^2 - 4x - 5} \right| + c$$

$$4. \int \frac{\sqrt{1+(\log x)^2}}{x} dx$$

**Solution:**  $I = \int \sqrt{1+(\log x)^2} \frac{1}{x} dx$

Put  $\log x = t$

$$\therefore \frac{1}{x} dx = dt$$

$$= \int \sqrt{1+t^2} dt$$

$$= \frac{t}{2} \sqrt{1+t^2} + \frac{1}{2} \log \left| t + \sqrt{1+t^2} \right| + c$$

$$= \frac{(\log x) \sqrt{1+(\log x)^2}}{2}$$

$$+ \frac{1}{2} \log \left| (\log x) + \sqrt{1+(\log x)^2} \right| + c$$

$$5. \int e^x \sqrt{e^{2x}+1} dx$$

**Solution:** Let  $e^x = t$

$$e^x dx = dt$$

$$I = \int \sqrt{t^2+1} dt$$

$$= \frac{t}{2} \sqrt{t^2+1} + \frac{1}{2} \log \left| t + \sqrt{t^2+1} \right| + c$$

$$= \frac{e^x \sqrt{e^{2x}+1}}{2} + \frac{1}{2} \log \left| e^x + \sqrt{e^{2x}+1} \right| + c$$

$$6. \int \sqrt{x^2+4x+13} dx$$

**Solution:**  $I = \int \sqrt{x^2+4x+4+9} dx$

$$= \int \sqrt{(x+2)^2+3^2} dx$$

$$= \frac{x+2}{2} \sqrt{(x+2)^2+3^2}$$

$$+ \frac{3^2}{2} \log \left| (x+2) + \sqrt{(x+2)^2+3^2} \right| + c$$

$$= \frac{x+2}{2} \sqrt{x^2+4x+13}$$

$$+ \frac{9}{2} \log \left| (x+2) + \sqrt{x^2+4x+13} \right| + c$$

$$7. \int \sqrt{x^2+x+1} dx$$

**Solution:**  $I = \int \sqrt{x^2+x+\frac{1}{4}+\frac{3}{4}} dx$

$$= \int \sqrt{\left(x+\frac{1}{2}\right)^2 + \left(\frac{\sqrt{3}}{2}\right)^2} dx$$

$$= \frac{1}{2} \left(x+\frac{1}{2}\right) \sqrt{x^2+x+1} + \frac{\left(\frac{\sqrt{3}}{2}\right)^2}{2}$$

$$\log \left| x+\frac{1}{2} + \sqrt{x^2+x+1} \right| + c$$

**Integrals of the form**  $\int (px+q)\sqrt{ax^2+bx+c} dx$

### SOLVED EXAMPLES

$$I = \int (3x-2)\sqrt{x^2+x+1} dx$$

**Solution:** We express  $3x-2 = A \frac{d(x^2+x+1)}{dx} + B$

$$3x-2 = A(2x+1) + B$$

$$= 2Ax + (A+B)$$

Comparing coefficients of  $x$  and constant term on both sides.

$$2A = 3 \text{ and } A+B = -2$$

$$A = 3/2 \text{ and } B = -7/2$$

$$\therefore I = \int \left[ \frac{3}{2}(2x+1) - \frac{7}{2} \right] \sqrt{x^2+x+1} dx$$

$$= \frac{3}{2} \int (2x+1)\sqrt{x^2+x+1} dx$$

$$- \int \frac{7}{2} \sqrt{x^2+x+1} dx$$

Let

$$I_1 = \int (2x+1)\sqrt{x^2+x+1} dx,$$

$$I_2 = \frac{-7}{2} \int \sqrt{x^2+x+1} dx$$

Put  $x^2+x+1 = t$  in  $I_1$

$$\therefore I_1 = \int \sqrt{t} dt = \int t^{1/2} dt$$

$$= \frac{t^{3/2}}{3/2} + c$$

$$I_1 = \frac{2}{3}(x^2 + x + 1)^{3/2} + c_1$$

$$\begin{aligned} I_2 &= \frac{-7}{2} \int \sqrt{x^2 + x + 1} dx \\ &= \frac{-7}{2} \left[ \frac{1}{2} \left( x + \frac{1}{2} \right) \sqrt{x^2 + x + 1} + \frac{3}{8} \log \right. \\ &\quad \left. \left| \left( x + \frac{1}{2} \right) + \sqrt{x^2 + x + 1} \right| \right] + c_2 \end{aligned}$$

$$I = I_1 + I_2$$

### EXERCISE 5.5

Evaluate the following.

1)  $\int x \log x$

2)  $\int x^2 e^{4x} dx$

3)  $\int x^2 e^{3x} dx$

4)  $\int x^3 e^{x^2} dx$

5)  $\int e^x \left( \frac{1}{x} - \frac{1}{x^2} \right) dx$

6)  $\int e^x \frac{x}{(x+1)^2} dx$

7)  $\int e^x \frac{x-1}{(x+1)^3} dx$

8)  $\int e^x \left[ (\log x)^2 + \frac{2 \log x}{x} \right] dx$

9)  $\int \left[ \frac{1}{\log x} - \frac{1}{(\log x)^2} \right] dx$

10)  $\int \frac{\log x}{(1 + \log x)^2} dx$

## 5.6 Integration by method of Partial Fractions:

### 5.6.1 Types of Partial Fractions.

- (1) If  $f(x)$  and  $g(x)$  are two polynomials then  $f(x)/g(x)$  is a rational function where  $g(x) \neq 0$ .
- (2) If degree of  $f(x) <$  degree of  $g(x)$  then  $f(x)/g(x)$  is a proper rational function.
- (3) If degree of  $f(x) \geq$  degree of  $g(x)$  then  $f(x)/g(x)$  is improper rational function.
- (4) If a function is improper then divide  $f(x)$  by  $g(x)$  and this rational function can be written in the following form  $\frac{f(x)}{g(x)} = \text{Quotient} + \frac{\text{Remainder}}{g(x)}$  and can be expressed as the sum of partial fractions using following table.

Type	Rational Form	Partial Form
1	$\frac{px \pm q}{(x-a)(x-b)}$	$\frac{A}{x-a} + \frac{B}{x-b}$
2	$\frac{px^2 \pm qx \pm r}{(x-a)(x-b)(x-c)}$	$\frac{A}{x-a} + \frac{B}{x-b} + \frac{C}{x-c}$
3	$\frac{px \pm q}{(x-a)^2}$	$\frac{A}{x-a} + \frac{B}{(x-a)^2}$
4	$\frac{px^2 \pm qx \pm r}{(x-a)^2(x-b)}$	$\frac{A}{x-a} + \frac{B}{(x-a)^2} + \frac{C}{x-b}$
5	$\frac{px^2 \pm qx \pm r}{(x-a)^3(x-b)}$	$\frac{A}{x-a} + \frac{B}{(x-a)^2} + \frac{C}{(x-a)^3} + \frac{D}{x-b}$
6	$\frac{px^2 \pm qx \pm r}{(x-a)(ax^2 \pm bx \pm c)}$	$\frac{A}{x-a} + \frac{Bx+C}{ax^2 \pm bx \pm c}$ where, $ax^2 \pm bx \pm c$ is non factorizable

## SOLVED EXAMPLES

1.  $\int \frac{x+1}{x^2+5x+6} dx$

**Solution:**  $I = \int \frac{x+1}{(x+2)(x+3)} dx$

Consider  $\frac{x+1}{(x+2)(x+3)} = \frac{A}{x+2} + \frac{B}{x+3}$

$x+1 = A(x+3) + B(x+2)$

Put  $x = -2$  and we get  $A = -1$

Put  $x = -3$  and we get  $B = 2$

$\frac{x+1}{(x+2)(x+3)} = \frac{-1}{x+2} + \frac{2}{x+3}$

$I = \int \frac{x+1}{x^2+5x+6} dx = \int \left( \frac{-1}{x+2} + \frac{2}{x+3} \right) dx$

$= -\int \frac{dx}{x+2} + 2\int \frac{1}{x+3} dx$

$= -\log|x+2| + 2\log|x+3| + c$

2.  $\int \frac{x^2+2}{(x-1)(x+2)(x+3)} dx$

**Solution:**  $I =$  Consider

$\frac{x^2+2}{(x-1)(x+2)(x+3)} = \frac{A}{x-1} + \frac{B}{x+2} + \frac{C}{x+3}$

$x^2+2 = A(x+2)(x+3) + B(x-1)(x+3) + C(x-1)(x+2)$

Put  $x = 1$   $A = 1/4$

Put  $x = -2$   $B = -2$

Put  $x = -3$   $C = 11/4$

$\frac{x^2+2}{(x-1)(x+2)(x+3)} = \frac{1/4}{x-1} + \frac{-2}{x+2} + \frac{11/4}{x+3}$

$\int \frac{x^2+2}{(x-1)(x+2)(x+3)} dx =$

$I = \int \left( \frac{1/4}{x-1} - \frac{2}{x+2} + \frac{11/4}{x+3} \right) dx$

$= \frac{1}{4} \int \frac{1}{1-x} dx - 2 \int \frac{1}{x+2} dx + \frac{11}{4} \int \frac{1}{x+3} dx$

$= \frac{1}{4} \log|x-1| - 2 \log|x+2| + \frac{11}{4} \log|x+3| + c$

3.  $\int \frac{\log x}{x(1+\log x)(2+\log x)} dx$

**Solution:** Put  $\log x = t$

$\frac{1}{x} dx = dt$

$I = \int \frac{t}{(1+t)(2+t)} dt$

Consider  $\frac{t}{(1+t)(2+t)} = \frac{A}{1+t} + \frac{B}{2+t}$

Put  $t = -1$   $A = -1$

Put  $t = -2$   $B = 2$

$I = \int \left[ \frac{-1}{1+t} + \frac{2}{2+t} \right] dt$

$= \int \frac{-1}{1+t} dt + 2 \int \frac{1}{2+t} dt$

$= -\log|t+1| + 2\log|t+2| + c$

$= 2\log|\log x + 2| - \log|\log x + 1| + c$

$= \log/(\log x + 2)^2 - \log/(\log x + 1) + c$

4.  $\int \frac{x^3-4x^2+3x+11}{x^2+5x+6} dx$

$\frac{x+1=Q}{[D = x^2-5x+6] \frac{x^3-4x^2+3x+11}{x^2-3x+11} - (x^3-5x^2+6x) \frac{x^2-3x+11}{x^2-5x+6} = R}$

Express  $\frac{x^3-4x^2+3x+11}{x^2-5x+6} = Q + \frac{R}{D}$

$= (x+1) + \frac{2x+5}{x^2-5x+6}$



$$\begin{aligned}
 I &= \int \frac{x^3 - 4x^2 + 3x + 11}{x^2 - 5x + 6} dx \\
 &= \int (x+1) dx + \int \frac{2x+5}{x^2 - 5x + 6} dx \\
 &= \frac{x^2}{2} + x + \int \frac{2x+5}{x^2 - 5x + 6} dx + c_1
 \end{aligned}$$

Express  $\frac{2x+5}{x^2 - 5x + 6} = \frac{A}{x-2} + \frac{B}{x-3}$

$$2x + 5 = A(x - 3) + B(x - 2)$$

Put  $x = 2$  we get  $A = -9$

Put  $x = 3$  we get  $B = 11$

$$\therefore \frac{2x+5}{x^2 - 5x + 6} = \frac{-9}{x-2} + \frac{11}{x-3}$$

$$\therefore I = \frac{x^2}{2} + x + \int \left( \frac{-9}{x-2} + \frac{11}{x-3} \right) dx + c$$

$$\begin{aligned}
 \therefore I &= \int \frac{x^3 - 4x^2 + 3x + 11}{x^2 - 5x + 6} dx = \frac{x^2}{2} + x \\
 &\quad - 9 \log|x-2| + 11 \log|x-3| + c
 \end{aligned}$$

5.  $\int \frac{3x+1}{(x-2)^2(x+2)} dx$

Express

$$\begin{aligned}
 \frac{3x+1}{(x-2)^2(x+2)} &= \frac{A}{x-2} + \frac{B}{(x-2)^2} + \frac{C}{x+2} \\
 3x + 1 &= A(x-2)(x+2) + B(x+2) + C(x-2)^2
 \end{aligned}$$

Put  $x = 2$   $B = 7/4$

$x = -2$ ,  $C = -5/16$

Comparing Coefficients of  $x^2$  on both sides we get

$$A + C = 0 \quad A = 5/16$$

$$\frac{3x+1}{(x-2)^2(x+2)} = \frac{5}{16(x-2)} + \frac{7}{4(x-2)^2} + \frac{-5}{16(x+2)}$$

$$I = \frac{5}{16} \int \frac{1}{x-2} dx + \frac{7}{4} \int \frac{1}{(x-2)^2} dx - \frac{5}{16} \int \frac{1}{x+2} dx$$

$$I = \frac{5}{16} \log|x-2| - \frac{7}{4} \frac{1}{(x-2)} - \frac{5}{16} \log|x+2| + c$$

### EXERCISE 5.6

Evaluate:

1)  $\int \frac{2x+1}{(x+1)(x-2)} dx$

2)  $\int \frac{2x+1}{x(x-1)(x-4)} dx$

3)  $\int \frac{x^2+x-1}{x^2+x-6} dx$

4)  $\int \frac{x}{(x-1)^2(x+2)} dx$

5)  $\int \frac{3x-2}{(x+1)^2(x+3)} dx$

6)  $\int \frac{1}{x(x^5+1)} dx$

7)  $\int \frac{1}{x(x^n+1)} dx$

8)  $\int \frac{5x^2+20x+6}{x^3+2x^2+x} dx$

### Activity

Evaluate:  $\int \frac{x-1}{(x-3)(x-2)} dx$

Now,  $\frac{x-1}{(x-3)(x-2)} = \frac{[ ]}{(x-3)} + \frac{[ ]}{(x-2)}$

There is no indicator of what the numerators should be, so there is work to be done to find them. If we let the numerator be variables, we can use algebra to solve. That is we want to find constants A and B that make equation 2 below true for  $x = 2, 3$  which are the same constants that make the following equation true.

$$\frac{x-1}{(x-3)(x-2)} = \frac{[A]}{(x-3)} + \frac{[B]}{(x-2)} \quad (1)$$

$$x-1 = A(x-2) + B(x-3) \quad (2)$$

$$[ \ ]x + [ \ ] = [ \ ]x + [ \ ] \quad (3)$$

**Note:** Two polynomials are equal if corresponding coefficients are equal. For linear functions, this means that  $ax + b = cx + d$  for all  $x$  exactly when  $a = c$  and  $b = d$

Alternately, you can evaluate equation (2) for various values of  $x$  to get equations relating  $A$  and  $B$ . Some values of  $x$  will be more helpful than others

$$[ \ ] = [ \ ]$$

$$[ \ ] = [ \ ]$$

continue solving for the constants  $A$  and  $B$ .

$$A = \quad , B =$$

$$\therefore \frac{x-1}{(x-3)(x-2)} = \frac{[ \ ]}{(x-3)} + \frac{[ \ ]}{(x-2)}$$

$$\therefore \int \frac{x-1}{(x-3)(x-2)} dx = \int \frac{[ \ ]}{(x-3)} dx + \int \frac{[ \ ]}{(x-2)} dx$$

$$I = [ \ ] + [ \ ] + c$$



### Let's Remember

#### Rules of Integration:

- $\int [f(x) \pm g(x)] dx = \int f(x) dx \pm \int g(x) dx$
- $\int k f(x) dx = k \int f(x) dx$ ; where  $k$  is a constant.
- If  $\int f(x) dx = g(x) + c$  then,

$$\int f(ax+b) dx = \frac{1}{a} g(ax+b) + c; a \neq 0$$

#### Standard Integration Formulae.

$$1. \int (ax+b)^n dx = \frac{(ax+b)^{n+1}}{a(n+1)} + c; \text{ if } n \neq -1$$

$$2. \int \frac{1}{(ax+b)} dx = \frac{\log|ax+b|}{a} + c$$

$$3. \int e^{ax+b} dx = \frac{e^{ax+b}}{a} + c$$

$$4. \int a^{bx+k} dx = \frac{a^{bx+k}}{b \cdot \log a} + c$$

$$5. \int \sqrt{x^2+a^2} dx = \frac{x}{2} \sqrt{x^2+a^2} + \frac{a^2}{2} \log|x+\sqrt{x^2+a^2}| + c$$

$$6. \int \sqrt{x^2-a^2} dx = \frac{x}{2} \sqrt{x^2-a^2} - \frac{a^2}{2} \log|x+\sqrt{x^2-a^2}| + c$$

$$7. \int \frac{f'(x)}{f(x)} dx = \log|f(x)| + c$$

$$8. \int \frac{f'(x)}{\sqrt{f(x)}} dx = 2\sqrt{f(x)} + c$$

$$9. \int [f(x)]^n f'(x) dx = \frac{[f(x)]^{n+1}}{n+1} + c, n \neq -1$$

$$10. \int \frac{1}{x^2-a^2} dx = \frac{1}{2a} \log \left| \frac{x-a}{x+a} \right| + c$$

$$11. \int \frac{1}{a^2-x^2} dx = \frac{1}{2a} \log \left| \frac{a+x}{a-x} \right| + c$$

$$12. \int \frac{dx}{\sqrt{x^2+a^2}} = \log|x+\sqrt{x^2+a^2}| + c$$

$$13. \int \frac{dx}{\sqrt{x^2-a^2}} = \log|x+\sqrt{x^2-a^2}| + c$$

## MISCELLANEOUS EXERCISE - 5

### I. Choose the correct alternative from the following.

1) The value of  $\int \frac{dx}{\sqrt{1-x}}$  is

- a)  $2\sqrt{1-x} + c$       b)  $-2\sqrt{1-x} + c$   
 c)  $\sqrt{x} + c$       d)  $x + c$

2)  $\int \sqrt{1+x^2} dx =$

- a)  $\frac{x}{2}\sqrt{1+x^2} + \frac{1}{2}\log(x + \sqrt{1+x^2}) + c$   
 b)  $\frac{2}{3}(1+x^2)^{3/2} + c$   
 c)  $\frac{1}{3}(1+x^2) + c$       d)  $\frac{(x)}{\sqrt{1+x^2}} + c$

3)  $\int x^2(3)^{x^3} dx =$

- a)  $(3)^{x^3} + c$       b)  $\frac{(3)^{x^3}}{3 \cdot \log 3} + c$   
 c)  $\log 3(3)^{x^3} + c$       d)  $x^2(3)^{x^3}$

4)  $\int \frac{x+2}{2x^2+6x+5} dx = p \int \frac{4x+6}{2x^2+6x+5} dx + \frac{1}{2}$

$\int \frac{dx}{2x^2+6x+5}$  then P = ?

- a)  $\frac{1}{3}$       b)  $\frac{1}{2}$   
 c)  $\frac{1}{4}$       d) 2

5)  $\int \frac{dx}{(x-x^2)} =$

- a)  $\log x - \log(1-x) + c$   
 b)  $\log(1-x^2) + c$

c)  $-\log x + \log(1-x) + c$

d)  $\log(x-x^2) + c$

6)  $\int \frac{dx}{(x-8)(x+7)} =$

a)  $\frac{1}{15} \log \left| \frac{x+2}{x-1} \right| + c$

b)  $\frac{1}{15} \log \left| \frac{x+8}{x+7} \right| + c$

c)  $\frac{1}{15} \log \left| \frac{x-8}{x+7} \right| + c$

d)  $(x-8)(x-7) + c$

7)  $\int \left(x + \frac{1}{x}\right)^3 dx =$

a)  $\frac{1}{4} \left(x + \frac{1}{x}\right)^4 + c$

b)  $\frac{x^4}{4} + \frac{3x^2}{2} + 3 \log x - \frac{1}{2x^2} + c$

c)  $\frac{x^4}{4} + \frac{3x^2}{2} + 3 \log x + \frac{1}{x^2} + c$

d)  $(x - x^{-1})^3 + c$

8)  $\int \left(\frac{e^{2x} + e^{-2x}}{e^x}\right) dx =$

a)  $e^x - \frac{1}{3e^{3x}} + c$       b)  $e^x + \frac{1}{3e^{3x}} + c$

c)  $e^{-x} + \frac{1}{3e^{3x}} + c$       d)  $e^{-x} + \frac{1}{3e^{3x}} + c$

9)  $\int (1-x)^{-2} dx =$

a)  $(1+x)^{-1} + c$       b)  $(1-x)^{-1} + c$

c)  $(1-x)^{-1} - 1 + c$       d)  $(1-x)^{-1} + 1 + c$

$$10) \int \frac{(x^3 + 3x^2 + 3x + 1)}{(x+1)^5} dx$$

- a)  $\frac{-1}{x+1} + c$       b)  $\left(\frac{-1}{x+1}\right)^5 + c$   
 c)  $\log(x+1) + c$       d)  $\log|x+1|^5 + c$

**II. Fill in the blanks.**

- $\int \frac{5(x^6 + 1)}{x^2 + 1} dx = x^4 + \dots x^3 + 5x + c$
- $\int \frac{x^2 + x - 6}{(x-2)(x-1)} dx = x + \dots + c$
- If  $f'(x) = \frac{1}{x} + x$  and  $f(1) = \frac{5}{2}$  then  
 $f(x) = \log x + \frac{x^2}{2} + \dots$
- To find the value of  $\int \frac{(1 + \log x) dx}{x}$  the proper substitution is .....
- $\int \frac{1}{x^3} [\log x^x]^2 dx = p(\log x)^3 + c$  then P = .....

**III. State whether each of the following is True or False.**

- The proper substitution for  $\int x(x^x)^x (2 \log x + 1) dx$  is  $(x^x)^x = t$
- If  $\int x e^{2x} dx$  is equal to  $e^{2x} f(x) + c$  where C is constant of integration then  $f(x)$  is  $\frac{(2x-1)}{2}$
- If  $\int x f(x) dx = \frac{f(x)}{2}$  then  $f(x) = e^{x^2}$
- If  $\int \frac{(x-1) dx}{(x+1)(x-2)} = A \log|x+1| + B \log|x-2|$  then  $A + B = 1$
- For  $\int \frac{x-1}{(x+1)^3} e^x dx = e^x f(x) + c$ ,  $f(x) = (x+1)^2$ .

**IV. Solve the following:**

**1) Evaluate.**

- $\int \frac{5x^2 - 6x + 3}{2x - 3} dx$
- $\int (5x+1)^{\frac{4}{9}} dx$
- $\int \frac{1}{(2x+3)} dx$
- $\int \frac{x-1}{\sqrt{x+4}} dx$
- If  $f'(x) = \sqrt{x}$  and  $f(1) = 2$  then find the value of  $f(x)$ .
- $\int |x| dx$  if  $x < 0$

**2) Evaluate.**

- Find the primitive of  $\frac{1}{1+e^x}$
- $\int \frac{ae^{-x} + be^{-x}}{(ae^{-x} - be^{-x})} dx$
- $\int \frac{1}{2x + 3x \log x} dx$
- $\int \frac{1}{\sqrt{x+x}} dx$
- $\int \frac{2e^x - 3}{4e^x + 1} dx$

**3) Evaluate.**

- $\int \frac{dx}{\sqrt{4x^2 - 5}}$
- $\int \frac{dx}{3 - 2x - x^2}$
- $\int \frac{dx}{9x^2 - 25}$

$$\text{iv) } \int \frac{e^x}{\sqrt{e^{2x} + 4e^x + 13}} dx$$

$$\text{v) } \int \frac{dx}{x[(\log x)^2 + 4\log x - 1]}$$

$$\text{vi) } \int \frac{dx}{5 - 16x^2}$$

$$\text{vii) } \int \frac{dx}{25x - x(\log x)^2}$$

$$\text{viii) } \int \frac{e^x}{4e^{2x} - 1} dx$$

#### 4) Evaluate.

$$\text{i) } \int (\log x)^2 dx$$

$$\text{ii) } \int e^x \frac{1+x}{(2+x)^2} dx$$

$$\text{iii) } \int xe^{2x} dx$$

$$\text{iv) } \int \log(x^2 + x) dx$$

$$\text{v) } \int e^{\sqrt{x}} dx$$

$$\text{vi) } \int \sqrt{x^2 + 2x + 5} dx$$

$$\text{vii) } \int \sqrt{x^2 - 8x + 7} dx$$

#### 5) Evaluate.

$$\text{i) } \int \frac{3x-1}{2x^2-x-1} dx$$

$$\text{ii) } \int \frac{2x^3 - 3x^2 - 9x + 1}{2x^2 - x - 10} dx$$

$$\text{iii) } \int \frac{(1 + \log x)}{x(3 + \log x)(2 + 3\log x)} dx$$

### Activities

$$1) \int \frac{1}{(x^2 - 5x + 4)} 2x dx$$

**Solution:**  $\frac{2x}{(x^2 - 5x + 4)} = \frac{C}{(x-4)} + \frac{D}{(x-1)}$

$$\therefore 2x = C(x-4) + D(x-1)$$

$$\therefore C = \square, D = \square$$

$$\therefore \int \frac{2x}{(x-1)(x-4)} dx = \int \left[ \frac{\square}{(x-1)} + \frac{\square}{(x-4)} \right] dx$$

$$= \int \frac{\square}{(x-1)} dx + \int \frac{\square}{(x-4)} dx$$

$$= \square + \square + c$$

$$2) \int x^{13/2} (1 + x^{5/2})^{1/2} dx$$

**Solution:**  $\int x^{\square} x^{3/2} (1 + x^{5/2})^{1/2} dx = \int (x^{5/2})^2 x^{3/2} (1 + x^{5/2}) dx$

let  $1 + x^{5/2} = t$

$$\square dx = \square dt$$

$$I = \frac{2}{5} \int (t-1)^2 t^{1/2} dt$$

$$= \frac{2}{5} \int (t^2 - 2t + 1) t^{1/2} dt$$

$$= \frac{2}{5} \left[ \int \square dt - \int \square dt + \int \square dt \right]$$

$$= \frac{2}{5} \{ \square - \square + \square \} + c$$

$$3) \int \frac{dx}{(x+2)(x^2+1)} =$$

$$\left( \int \frac{1}{x^2+1} dx = \tan^{-1} x + c \right) \dots \dots \dots (\text{given})$$

**Solution:**  $\frac{1}{(x+2)(x^2+1)} = \frac{\square}{(x+2)} + \frac{Bx+C}{(x^2+1)}$

$$\therefore 1 = A(x^2 + 1) + (Bx + C)(x + 2)$$

Put  $x = -2$  we get  $A = \frac{1}{5}$

Now comparing the coefficients of  $x^2$  and constant term, we get

$$0 = A + B$$

$$\text{and } 1 = A + 2C$$

$$\therefore B = \frac{-1}{5}, \quad C = \frac{2}{5}$$

$$\frac{1}{(x+2)(x^2+1)} = \frac{\square}{(x+2)} + \frac{\square x + \square}{(x^2+1)}$$

$$I = \int \frac{dx}{(x+2)} - \int \frac{\square x}{x^2+1} dx + \square \int \frac{dx}{x^2+1}$$

$$= \square - \square + \square + c$$

4) If  $\int \frac{1}{x^5+x} dx = f(x) + c = f(x) + C$ , then the

value of  $\int \frac{x^4}{x+x^5} dx$  is equal to .....

$$I = \int \left[ \frac{x^4+1-1}{x+x^5} \right] dx =$$

$$= \int \frac{1}{x} dx - \int \frac{1}{x^5+x} dx$$

$$I = \log x - f(x) + c$$

$$I = \log x - f(x) + c_1 \quad \dots\dots c_1 = -c$$



## 6

## Definite Integration



## Let's Study

- Definite Integral
- Properties of Definite Integral



## Introduction

We know that if  $f(x)$  is a continuous function of  $x$ , then there exists a function  $\phi(x)$  such that  $\phi'(x) = f(x)$ . In this case,  $\phi(x)$  is an integral of  $f(x)$  with respect to  $x$  and we denote it by  $\int f(x) dx = \phi(x) + c$ . Now, if we restrict the domain of  $f(x)$  to  $(a, b)$ , then the difference  $\phi(b) - \phi(a)$  is called definite integral of  $f(x)$  w.r.t.  $x$  on the interval

$[a, b]$  and is denoted by  $\int_a^b f(x) dx$ .

$$\text{Thus } \int_a^b f(x) dx = \phi(b) - \phi(a)$$

The numbers  $a$  and  $b$  are called limits of integration, ' $a$ ' is referred to as the lower limit of integral and  $b$  is the upper limit of integral.

Note that the domain of the variable  $x$  is restricted to the interval  $(a, b)$  and  $a, b$  are finite numbers.



## Let's Learn

## 6.1 Fundamental theorem of Integral Calculus.

Let  $f$  be a continuous function defined on  $(a, b)$

$$\int f(x) dx = \phi(x) + c.$$

$$\begin{aligned} \text{Then } \int_a^b f(x) dx &= [\phi(x) + c]_a^b \\ &= [\phi(b) + c] - [\phi(a) + c] \\ &= \phi(b) - \phi(a) \end{aligned}$$

There is no need of taking the constant of integration  $c$ , because it gets eliminated.

## SOLVED EXAMPLES

## Ex 1 : Evaluate:

$$\text{i) } \int_2^3 x^4 dx$$

$$\text{ii) } \int_0^1 \frac{1}{(2x+5)} dx$$

$$\text{iii) } \int_0^1 \frac{1}{\sqrt{1+x} + \sqrt{x}} dx$$

## Solution:

$$\text{i) Here } f(x) = x^4, \phi(x) = \frac{x^5}{5} + c$$

$$\int_2^3 f(x) dx = [\phi(x)]_2^3$$

$$\begin{aligned} \int_2^3 x^4 dx &= \left[ \frac{x^5}{5} \right]_2^3 = \frac{3^5}{5} - \frac{2^5}{5} \\ &= \frac{243}{5} - \frac{32}{5} = \frac{211}{5} \end{aligned}$$

$$\begin{aligned} \text{ii) } \int_0^1 \frac{1}{(2x+5)} dx &= \frac{1}{2} [\log/2x + 5]_0^1 \\ &= \frac{1}{2} [\log 7 - \log 5] \\ &= \frac{1}{2} \log \frac{7}{5} \end{aligned}$$

$$\begin{aligned} \text{iii) } \int_0^1 \frac{1}{\sqrt{1+x} + \sqrt{x}} dx &= \int_0^1 \frac{\sqrt{1+x} - \sqrt{x}}{(\sqrt{1+x} + \sqrt{x})(\sqrt{1+x} - \sqrt{x})} dx \\ &= \int_0^1 \frac{\sqrt{1+x} - \sqrt{x}}{1+x-x} dx \end{aligned}$$

$$\begin{aligned}
&= \int_0^1 (\sqrt{1+x} - \sqrt{x}) dx \\
&= \left[ \frac{2}{3}(1+x)^{\frac{3}{2}} - \frac{2}{3}x^{\frac{3}{2}} \right]_0^1 \\
&= \left[ \frac{2}{3}(1+1)^{\frac{3}{2}} - \frac{2}{3}(1)^{\frac{3}{2}} \right] - \left[ \frac{2}{3}(1+0)^{\frac{3}{2}} - \frac{2}{3}(0)^{\frac{3}{2}} \right] \quad \text{ii)} \\
&= \frac{2}{3} \left[ 2^{\frac{3}{2}} - 1 \right] - \frac{2}{3} [1 - 0] \\
&= \frac{2}{3} \left[ 2^{\frac{3}{2}} - 2 \right] \\
&= \frac{2}{3} [2\sqrt{2} - 2] \\
&= \frac{4}{3} [\sqrt{2} - 1]
\end{aligned}$$

$$[x^3 + x^2 + ax]_0^1 = 0$$

$$(1+1+a) - 0 = 0$$

$$2+a-0=0$$

$$a = -2$$

$$\int_0^a 3x^2 dx = 8$$

$$3 \left[ \frac{x^3}{3} \right]_0^a = 8$$

$$(a^3 - 0^3) = 8$$

$$a^3 = 8$$

$$a = 2$$

$$\text{iii)} \int_a^b x^3 dx = 0 \quad \text{and} \quad \int_a^b x^2 dx = \frac{2}{3}$$

$$\therefore \left[ \frac{x^4}{4} \right]_a^b = 0 \quad \text{and} \quad \left[ \frac{x^3}{3} \right]_a^b = \frac{2}{3}$$

$$\therefore \frac{1}{4}(b^4 - a^4) = 0 \quad \text{and} \quad \frac{1}{3}(b^3 - a^3) = \frac{2}{3}$$

$$\therefore b^4 - a^4 = 0 \quad \text{and} \quad b^3 - a^3 = 2$$

$$\therefore b^4 = a^4 \quad \therefore b = \pm a$$

But  $b = a$  does not satisfy  $b^3 - a^3 = 2$

$$\therefore b \neq a$$

$$\therefore b = -a$$

Substituting  $b = -a$  in  $b^3 - a^3 = 2$

$$\text{We get } (-a)^3 - a^3 = 2, \quad -2a^3 = 2$$

We get  $a = -1$

$$\therefore b = -a = 1$$

$$\therefore a = -1, \quad b = 1$$

$$\text{iv)} \int_0^a 4x^3 dx = 16$$

$$\therefore 4 \left[ \frac{x^4}{4} \right]_0^a = 16$$

$$\frac{4}{4} [a^4 - 0] = 16$$

### Ex 2 : Evaluate:

$$\text{i)} \quad \text{If } \int_0^1 (3x^2 + 2x + a) dx = 0; \text{ find } a.$$

$$\text{ii)} \quad \text{If } \int_0^a 3x^2 dx = 8; \text{ find the value of } a.$$

$$\text{iii)} \quad \int_a^b x^3 dx = 0 \quad \text{and} \quad \int_a^b x^2 dx = \frac{2}{3}. \text{ Find the values of } a \text{ and } b.$$

$$\text{iv)} \quad \text{If } \int_0^a 4x^3 dx = 16, \text{ find } \alpha$$

v) If  $f(x) = a + bx + cx^2$ , show that

$$\int_0^1 f(x) dx = \frac{1}{6} \left[ f(0) + 4f\left(\frac{1}{2}\right) + f(1) \right]$$

### Solution:

$$\text{i)} \quad \int_0^1 (3x^2 + 2x + a) dx = 0$$

$$\text{Then } \left[ 3 \frac{x^3}{3} + 2 \frac{x^2}{2} + ax \right]_0^1 = 0$$



$$a^4 = 16$$

$$\therefore a = 2$$

$$\begin{aligned} \text{v) } \int_0^1 f(x) dx &= \int_0^1 (a + bx + cx^2) dx \\ &= a \int_0^1 1 dx + b \int_0^1 x dx + c \int_0^1 x^2 dx \\ &= \left[ ax + \frac{bx^2}{2} + \frac{cx^3}{3} \right]_0^1 \\ &= a + \frac{b}{2} + \frac{c}{3} \dots \dots \dots (1) \end{aligned}$$

$$\text{Now } f(0) = a + b(0) + c(0)^2 = a$$

$$f(1/2) = a + b(1/2) + c(1/2)^2 = a + b/2 + c/4$$

$$\text{and } f(1) = a + b + c$$

$$\begin{aligned} \therefore \frac{1}{6} \left[ f(0) + 4f\left(\frac{1}{2}\right) + f(1) \right] &= \frac{1}{6} \left[ a + 4\left(a + \frac{b}{2} + \frac{c}{4}\right) + (a + b + c) \right] \\ &= \frac{1}{6} [a + 4a + 2b + c + a + b + c] \\ &= \frac{1}{6} [6a + 3b + 2c] \\ &= a + \frac{b}{2} + \frac{c}{3} \dots \dots \dots (2) \end{aligned}$$

From (1) and (2)

$$\int_0^1 f(x) dx = \frac{1}{6} \left[ f(0) + 4f\left(\frac{1}{2}\right) + f(1) \right]$$

**Ex 3 : Evaluate:**

$$\text{i) } \int_0^2 \frac{1}{4+x-x^2} dx$$

$$\text{ii) } \int_0^4 \frac{dx}{\sqrt{x^2+2x+3}}$$

**Solution:**

$$\begin{aligned} \text{i) } \int_0^2 \frac{1}{4+x-x^2} dx &= \int_0^2 \frac{1}{-x^2+x+4} dx \\ &= \int_0^2 \frac{-1}{x^2-x+\frac{1}{4}-\frac{1}{4}-4} dx \\ &= \int_0^2 \frac{-1}{\left(x-\frac{1}{2}\right)^2 - \left(\frac{\sqrt{17}}{2}\right)^2} dx \\ &= \int_0^2 \frac{1}{\left(\frac{\sqrt{17}}{2}\right)^2 - \left(x-\frac{1}{2}\right)^2} dx \\ &= \frac{1}{\sqrt{17}} \left[ \log \left| \frac{\frac{\sqrt{17}}{2} + \left(x-\frac{1}{2}\right)}{\frac{\sqrt{17}}{2} - \left(x-\frac{1}{2}\right)} \right| \right]_0^2 \\ &= \frac{1}{\sqrt{17}} \left[ \log \left| \frac{\sqrt{17} + 2x - 1}{\sqrt{17} - 2x + 1} \right| \right]_0^2 \\ &= \frac{1}{\sqrt{17}} \left\{ \log \left( \frac{\sqrt{17} + 4 - 1}{\sqrt{17} - 4 + 1} \right) - \log \left( \frac{\sqrt{17} - 1}{\sqrt{17} + 1} \right) \right\} \\ &= \frac{1}{\sqrt{17}} \left\{ \log \left( \frac{\sqrt{17} + 3}{\sqrt{17} - 3} \right) - \log \left( \frac{\sqrt{17} - 1}{\sqrt{17} + 1} \right) \right\} \\ &= \frac{1}{\sqrt{17}} \log \left( \frac{\sqrt{17} + 3}{\sqrt{17} - 3} \times \frac{\sqrt{17} + 1}{\sqrt{17} - 1} \right) \\ &= \frac{1}{\sqrt{17}} \log \left( \frac{20 + 4\sqrt{17}}{20 - 4\sqrt{17}} \right) \\ &= \frac{1}{\sqrt{17}} \log \left( \frac{5 + \sqrt{17}}{5 - \sqrt{17}} \right) \end{aligned}$$

$$\begin{aligned}
\text{ii)} \quad & \int_0^4 \frac{dx}{\sqrt{x^2 + 2x + 3}} \\
&= \int_0^4 \frac{1}{\sqrt{x^2 + 2x + 1 - 1 + 3}} dx \\
&= \int_0^4 \frac{1}{\sqrt{(x+1)^2 + (\sqrt{2})^2}} dx \\
&= \left[ \log \left| (x+1) + \sqrt{(x+1)^2 + (\sqrt{2})^2} \right| \right]_0^4 \\
&= \left[ \log \left| (x+1) + \sqrt{x^2 + 2x + 3} \right| \right]_0^4 \\
&= \log(5 + \sqrt{16 + 8 + 3}) - \log(1 + \sqrt{3}) \\
&= \log(5 + 3\sqrt{3}) - \log(1 + \sqrt{3}) \\
&= \log \left[ \frac{5 + 3\sqrt{3}}{(1 + \sqrt{3})} \right]
\end{aligned}$$

**Ex. 4: Evaluate:**

$$\text{i)} \quad \int_1^2 \log x \, dx$$

$$\text{ii)} \quad \int_1^2 \frac{\log x}{x^2} \, dx$$

**Solution:**

$$\begin{aligned}
\text{i)} \quad I &= \int_1^2 \log x \, dx \\
I &= \int_1^2 \log x \cdot 1 \cdot dx \\
I &= \left[ \log x \cdot x \right]_1^2 - \int_1^2 \frac{1}{x} \, dx \\
&= \left[ x \log x - x \right]_1^2 \\
&= \left[ (2 \log 2 - 1 \log 1) \right] - [2 - 1] \\
&= (\log 4 - 0) - 1 \\
&= \log 4 - 1
\end{aligned}$$

$$\begin{aligned}
\text{ii)} \quad & \int_1^2 \frac{\log x}{x^2} \, dx \\
&= \int_1^2 \log x \cdot \frac{1}{x^2} \cdot dx \\
&= \int \log x \cdot \frac{1}{x^2} \cdot dx = \left[ \log x \left( \frac{-1}{x} \right) \right]_1^2 - \int_1^2 \frac{1}{x} \left( \frac{x^{-1}}{-1} \right) dx \\
&= \left[ \log x \left( \frac{-1}{x} \right) - \frac{1}{x} \right]_1^2 \\
&= \left( \frac{-1}{2} \log 2 + \log 1 \right) - \left( \frac{1}{2} - \frac{1}{1} \right) \\
&= \frac{-1}{2} \log 2 + \frac{1}{2} \\
&= \frac{1}{2} (-\log 2 + 1) \\
&= \frac{1}{2} (-\log 2 + \log e) \\
&= \frac{1}{2} \log \frac{e}{2}
\end{aligned}$$

**Ex. 5: Evaluate:**

$$\text{i)} \quad \int_1^2 \frac{1}{(x+1)(x+3)} \, dx$$

$$\text{ii)} \quad \int_1^3 \frac{1}{x(1+x^2)} \, dx$$

**Solution:**

$$\text{i)} \quad \int_1^2 \frac{1}{(x+1)(x+3)} \, dx$$

$$\text{Let } \frac{1}{(x+1)(x+3)} = \frac{A}{x+1} + \frac{B}{x+3}$$

$$1 = A(x+3) + B(x+1) \dots\dots\dots (1)$$

Putting  $x + 1 = 0$

i.e.  $x = -1$  in equation (i) we get  $A = \frac{1}{2}$

Putting  $x + 3 = 0$

i.e.  $x = -3$  in equation (i) we get  $B = \frac{-1}{2}$

$$\frac{1}{(x+1)(x+3)} = \frac{\frac{1}{2}}{(x+1)} + \frac{-\frac{1}{2}}{(x+3)}$$

$$\int_1^2 \frac{1}{(x+1)(x+3)} dx$$

$$= \frac{1}{2} \int_1^2 \frac{dx}{x+1} - \frac{1}{2} \int_1^2 \frac{dx}{x+3}$$

$$= \frac{1}{2} [\log|x+1| - \log|x+3|]_1^2$$

$$= \frac{1}{2} (\log 3 - \log 2) - \frac{1}{2} (\log 5 - \log 4)$$

$$= \frac{1}{2} \left[ \log \frac{3}{2} - \log \frac{5}{4} \right]$$

$$= \frac{1}{2} \log \left[ \frac{6}{5} \right]$$

ii)  $\int_1^3 \frac{1}{x(1+x^2)} dx$

Let  $\frac{1}{x(1+x^2)} = \frac{A}{x} + \frac{Bx+c}{1+x^2}$

$$1 = A(1+x^2) + (Bx+c)x \dots\dots\dots(1)$$

Putting  $x = 0$  in equation (i) we get  $A = 1$   
Comparing the coefficient of  $x^2$  and  $x$ , we get  $A + B = 0$ ,  $B = -1$  &  $C = 0$

$$\frac{1}{x(1+x^2)} = \frac{1}{x} - \frac{x}{1+x^2}$$

$$\int_1^3 \frac{dx}{x(1+x^2)}$$

$$= \int_1^3 \frac{1}{x} dx - \int_1^3 \frac{x}{1+x^2} dx$$

$$= [\log|x|]_1^3 - \frac{1}{2} [\log|1+x^2|]_1^3$$

$$= (\log 3 - \log 1) - \frac{1}{2} (\log 10 - \log 2)$$

$$= \log \left( \frac{3}{1} \right) - \frac{1}{2} \log \left( \frac{10}{2} \right)$$

$$= (\log 3 - \frac{1}{2} \log 5)$$

$$= \log 3 - \log 5^{1/2} = \log 3 - \log \sqrt{5}$$

$$= \log \left( \frac{3}{\sqrt{5}} \right)$$

**EXERCISE 6.1**

**Evaluate the following definite integrals:**

1.  $\int_4^9 \frac{1}{\sqrt{x}} dx$

2.  $\int_{-2}^3 \frac{1}{x+5} dx$

3.  $\int_2^3 \frac{x}{x^2-1} dx$

4.  $\int_0^1 \frac{x^2+3x+2}{\sqrt{x}} dx$

5.  $\int_2^3 \frac{x}{(x+2)(x+3)} dx$

6.  $\int_1^2 \frac{dx}{x^2+6x+5}$

7. If  $\int_0^a (2x+1) dx = 2$ , find the real value of  $a$ .

8. If  $\int_1^a (3x^2+2x+1) dx = 11$ , find  $a$ .

9.  $\int_0^1 \frac{1}{\sqrt{1+x}+\sqrt{x}} dx$

10.  $\int_1^2 \frac{3x}{(9x^2-1)} dx$

11.  $\int_1^3 \log x dx$

## 6.2 Properties of definite integrals

In this section we will study some properties of definite integrals which are very useful in evaluating integrals.

Property 1 :  $\int_a^a f(x) dx = 0$

Property 2 :  $\int_a^b f(x) dx = -\int_b^a f(x) dx$

Property 3 :  $\int_a^b f(x) dx = \int_a^b f(t) dt$

Property 4 :  $\int_a^b f(x) dx = \int_a^c f(x) dx + \int_c^b f(x) dx$ , where  $a < c < b$

Property 5 :  $\int_a^b f(x) dx = \int_a^b f(a+b-x) dx$

Property 6 :  $\int_0^a f(x) dx = \int_0^a f(a-x) dx$

Property 7 :  $\int_0^{2a} f(x) dx = \int_0^a f(x) dx + \int_0^a f(2a-x) dx$

[If  $f(-x) = f(x)$ ,  $f(x)$  is an even function. If  $f(-x) = -f(x)$ ,  $f(x)$  is an odd function.]

Property 8 :  $\int_{-a}^a f(x) dx = 2 \int_0^a f(x) dx$  if  $f$  is an even function  
 $= 0$  if  $f$  is an odd function

### SOLVED EXAMPLES

Ex. Evaluate the following integrals:

1.  $\int_{-1}^1 f(x) dx$  where  $f(x) = \begin{cases} 1-2x; x \leq 0 \\ 1+2x; x \geq 0 \end{cases}$

2.  $\int_0^1 x(1-x)^n dx$

3.  $\int_0^3 \frac{\sqrt[3]{x+4}}{\sqrt[3]{x+4} + \sqrt[3]{7-x}} dx$

4.  $\int_a^b \frac{f(x)}{f(x) + f(a+b-x)} dx$

5.  $\int_4^7 \frac{(11-x^2)}{x^2 + (11-x^2)} dx$

**Solution:**

1.  $\int_{-1}^1 f(x) dx = \int_{-1}^0 f(x) dx + \int_0^1 f(x) dx$   
 $= \int_{-1}^0 (1-2x) dx + \int_0^1 (1+2x) dx$   
 $= [x - x^2]_{-1}^0 + [x + x^2]_0^1$   
 $= [0 - (-1 - 1)] + [(1 + 1) - 0]$   
 $= 2 + 2 = 4$

2.  $\int_0^1 x(1-x)^n dx$   
 By property  $\int_0^a f(x) dx = \int_0^a f(a-x) dx$

I =  $\int_0^1 (1-x)[1-(1-x)]^n dx$   
 $= \int_0^1 (1-x)x^n dx$   
 $= \int_0^1 (x^n - x^{n+1}) dx$   
 $= \left[ \frac{x^{n+1}}{n+1} \right]_0^1 - \left[ \frac{x^{n+2}}{n+2} \right]_0^1$   
 $= \frac{1}{n+1} - \frac{1}{n+2} = \frac{(n+2) - (n+1)}{(n+1)(n+2)}$   
 $= \frac{1}{(n+1)(n+2)}$

3. Let I =  $\int_0^3 \frac{\sqrt[3]{x+4}}{\sqrt[3]{x+4} + \sqrt[3]{7-x}} dx$  ..... (1)

By property  $\int_0^a f(x) dx = \int_0^a f(a-x) dx$

$$I = \int_0^3 \frac{\sqrt[3]{(3-x)+4}}{\sqrt[3]{(3-x)+4} + \sqrt[3]{7-(3-x)}} dx$$

$$= \int_0^3 \frac{\sqrt[3]{7-x}}{\sqrt[3]{7-x} + \sqrt[3]{x+4}} dx \quad \dots\dots\dots (2)$$

On adding equations (1) and (2)

$$2I = \int_0^3 \left[ \frac{\sqrt[3]{x+4}}{\sqrt[3]{7-x} + \sqrt[3]{x+4}} + \frac{\sqrt[3]{7-x}}{\sqrt[3]{7-x} + \sqrt[3]{x+4}} \right] dx$$

$$= \int_0^3 \frac{\sqrt[3]{x+4} + \sqrt[3]{(7-x)}}{\sqrt[3]{x+4} + \sqrt[3]{(7-x)}} dx$$

$$= \int_0^3 1 dx$$

$$= [x]_0^3$$

$$2I = 3$$

$$I = \frac{3}{2}$$

$$\therefore \int_0^3 \frac{\sqrt[3]{(x+4)}}{\sqrt[3]{(x+4)} + \sqrt[3]{(7-x)}} dx = \frac{3}{2}$$

$$4. \int_a^b \frac{f(x)}{f(x) + f(a+b-x)} dx \quad \dots\dots (1)$$

By property  $\int_a^b f(x) dx = \int_a^b f(a+b-x) dx$

$$I = \int_a^b \frac{f(a+b-x)}{f(a+b-x) + f[(a+b-(a+b-x))]} dx$$

$$I = \int_a^b \frac{f(a+b-x)}{f(a+b-x) + f(x)} dx \quad \dots\dots\dots (2)$$

Adding equations (1) and (2) we get,

$$2I = \int_a^b \frac{f(x)}{f(x) + f(a+b-x)} dx +$$

$$\int_a^b \frac{f(a+b-x)}{f(a+b-x) + f(x)} dx$$

$$= \int_a^b \frac{f(x) + f(a+b-x)}{f(x) + f(a+b-x)} dx$$

$$= \int_a^b 1 dx$$

$$= [x]_a^b$$

$$2I = b - a$$

$$I = \frac{b-a}{2}$$

$$\therefore \int_a^b \frac{f(x)}{f(x) + f(a+b-x)} dx = \frac{b-a}{2}$$

$$5. \int_4^7 \frac{(11-x^2)}{x^2 + (11-x^2)} dx \quad \dots\dots(1)$$

$$= \int_4^7 \frac{x^2}{(11-x^2) + x^2} dx \quad \dots\dots(2)$$

By Property

$$\int_a^b f(x) dx = \int_a^b f(a+b-x) dx$$

Adding equations (1) and (2)

$$2I = \int_4^7 \frac{(11-x^2)}{x^2 + (11-x^2)} dx + \int_4^7 \frac{x^2}{(11-x^2) + x^2} dx$$

$$= \int_4^7 \frac{(x^2) + (11-x^2)}{(x^2) + (11-x^2)} dx$$

$$= \int_4^7 1 dx$$

$$= [x]_4^7$$

$$2I = 3$$

$$I = \frac{3}{2}$$

$$\therefore \int_4^7 \frac{(11-x^2)}{x^2 + (11-x^2)} dx = \frac{3}{2}$$

## EXERCISE 6.2

**Evaluate the following integrals:**

1)  $\int_{-9}^9 \frac{x^3}{4-x^2} dx$

2)  $\int_0^a x^2 (a-x)^{3/2} dx$

3)  $\int_1^3 \frac{\sqrt[3]{x+5}}{\sqrt[3]{x+5} + \sqrt[3]{9-x}} dx$

4)  $\int_2^5 \frac{\sqrt{x}}{\sqrt{x} + \sqrt{7-x}} dx$

5)  $\int_1^2 \frac{\sqrt{x}}{\sqrt{3-x} + \sqrt{x}} dx$

6)  $\int_2^7 \frac{\sqrt{x}}{\sqrt{x} + \sqrt{9-x}} dx$

7)  $\int_0^1 \log\left(\frac{1}{x} - 1\right) dx$

8)  $\int_0^1 x(1-x)^5 dx$



### Let's Remember

● **Rules for evaluating definite integrals.**

1)  $\int_a^b [f(x) \pm g(x)] dx = \int_a^b f(x) dx \pm \int_a^b g(x) dx$

2)  $\int_a^b k f(x) dx = k \int_a^b f(x) dx$

● **Properties of definite integrals**

1)  $\int_a^a f(x) dx = 0$

2)  $\int_a^b f(x) dx = -\int_b^a f(x) dx$

3)  $\int_a^b f(x) dx = \int_a^c f(x) dx + \int_c^b f(x) dx$

4)  $\int_a^b f(x) dx = \int_a^b f(t) dt$

5)  $\int_0^a f(x) dx = \int_0^a f(a-x) dx$

6)  $\int_a^b f(x) dx = \int_a^b f(a+b-x) dx$

7)  $\int_0^{2a} f(x) dx = \int_0^a f(x) dx + \int_0^a f(2a-x) dx$

8)  $\int_{-a}^a f(x) dx = 2 \int_0^a f(x) dx$ , if  $f$  is even function,  
 $= 0$  , if  $f$  is odd function

## MISCELLANEOUS EXERCISE - 6

**I) Choose the correct alternative.**

1)  $\int_{-9}^9 \frac{x^3}{4-x^2} dx =$

- a) 0      b) 3      c) 9      d) -9

2)  $\int_{-2}^3 \frac{dx}{x+5} =$

- a)  $-\log\left(\frac{8}{3}\right)$       b)  $\log\left(\frac{8}{3}\right)$   
 c)  $\log\left(\frac{3}{8}\right)$       d)  $-\log\left(\frac{3}{8}\right)$

3)  $\int_2^3 \frac{x}{x^2-1} dx =$

- a)  $\log\left(\frac{8}{3}\right)$       b)  $-\log\left(\frac{8}{3}\right)$   
 c)  $\frac{1}{2} \log\left(\frac{8}{3}\right)$       d)  $-\frac{1}{2} \log \frac{8}{3}$

4)  $\int_4^9 \frac{dx}{\sqrt{x}} =$   
 a) 9      b) 4      c) 2      d) 0

5) If  $\int_0^a 3x^2 dx = 8$  then  $a = ?$   
 a) 2      b) 0      c)  $\frac{8}{3}$       d) a

6)  $\int_2^3 x^4 dx =$   
 a)  $\frac{1}{2}$       b)  $\frac{5}{2}$       c)  $\frac{5}{211}$       d)  $\frac{211}{5}$

7)  $\int_0^2 e^x dx =$   
 a)  $e - 1$       b)  $1 - e$   
 c)  $1 - e^2$       d)  $e^2 - 1$

8)  $\int_a^b f(x) dx =$   
 a)  $\int_b^a f(x) dx$       b)  $-\int_a^b f(x) dx$   
 c)  $-\int_b^a f(x) dx$       d)  $\int_0^a f(x) dx$

9)  $\int_{-7}^7 \frac{x^3}{x^2 + 7} dx =$   
 a) 7      b) 49      c) 0      d)  $\frac{7}{2}$

10)  $\int_2^7 \frac{\sqrt{x}}{\sqrt{x} + \sqrt{9-x}} dx =$   
 a)  $\frac{7}{2}$       b)  $\frac{5}{2}$       c) 7      d) 2

**II) Fill in the blanks.**

1)  $\int_0^2 e^x dx = \dots\dots\dots$

2)  $\int_2^3 x^4 dx = \dots\dots\dots$

3)  $\int_0^1 \frac{dx}{2x+5} = \dots\dots\dots$

4) If  $\int_0^a 3x^2 dx = 8$  then  $a = \dots\dots\dots$

5)  $\int_4^9 \frac{1}{\sqrt{x}} dx = \dots\dots\dots$

6)  $\int_2^3 \frac{x}{x^2-1} dx = \dots\dots\dots$

7)  $\int_{-2}^3 \frac{dx}{x+5} = \dots\dots\dots$

8)  $\int_{-9}^9 \frac{x^3}{4-x^2} dx = \dots\dots\dots$

**III) State whether each of the following is True or False**

1)  $\int_a^b f(x) dx = \int_{-b}^{-a} f(x) dx$

2)  $\int_a^b f(x) dx = \int_a^b f(t) dt$

3)  $\int_0^a f(x) dx = \int_a^0 f(a-x) dx$

4)  $\int_a^b f(x) dx = \int_a^b f(x-a-b) dx$

5)  $\int_{-5}^5 \frac{x^3}{x^2+7} dx = 0$

$$6) \int_1^2 \frac{\sqrt{x}}{\sqrt{3-x} + \sqrt{x}} dx = \frac{1}{2}$$

$$7) \int_2^7 \frac{\sqrt{x}}{\sqrt{x} + \sqrt{9-x}} dx = \frac{9}{2}$$

$$8) \int_4^7 \frac{(11-x)^2}{(11-x)^2 + x^2} dx = \frac{3}{2}$$

#### IV Solve the following.

$$1) \int_2^3 \frac{x}{(x+2)(x+3)} dx$$

$$2) \int_1^2 \frac{x+3}{x(x+2)} dx$$

$$3) \int_1^3 x^2 \log x dx$$

$$4) \int_0^1 e^{x^2} x^3 dx$$

$$5) \int_1^2 e^{2x} \left( \frac{1}{x} - \frac{1}{2x^2} \right) dx$$

$$6) \int_4^9 \frac{1}{\sqrt{x}} dx$$

$$7) \int_{-2}^3 \frac{1}{x+5} dx$$

$$8) \int_2^3 \frac{x}{x^2-1} dx$$

$$9) \int_0^1 \frac{x^2 + 3x + 2}{\sqrt{x}} dx$$

$$10) \int_3^5 \frac{dx}{\sqrt{x+4} + \sqrt{x-2}}$$

$$11) \int_2^3 \frac{x}{x^2+1} dx$$

$$12) \int_1^2 x^2 dx$$

$$13) \int_{-4}^{-1} \frac{1}{x} dx$$

$$14) \int_0^1 \frac{1}{\sqrt{1+x} + \sqrt{x}} dx$$

$$15) \int_0^4 \frac{1}{\sqrt{x^2 + 2x + 3}} dx$$

$$16) \int_2^4 \frac{x}{x^2+1} dx$$

$$17) \int_0^1 \frac{1}{2x-3} dx$$

$$18) \int_1^2 \frac{5x^2}{x^2 + 4x + 3} dx$$

$$19) \int_1^2 \frac{dx}{x(1+\log x)^2}$$

$$20) \int_0^9 \frac{1}{1+\sqrt{x}} dx$$

#### Activities

1) Complete the following activity.

$$\text{If } \int_a^b x^3 dx = 0 \text{ then}$$

$$\left( \frac{x^4}{\square} \right)_a^b = 0$$

$$\therefore \frac{1}{4} (\square - \square) = 0$$

$$\therefore b^4 - \square = 0$$

$$\therefore (b^2 - a^2)(\square + \square) = 0$$

$$\therefore b^2 - \square = 0 \quad \text{as } a^2 + b^2 \neq 0$$

$$\therefore b = \pm \square$$



$$\begin{aligned}
2) \quad & \int_0^2 \frac{dx}{4+x-x^2} \\
&= \int_0^2 \frac{dx}{-x^2 + \square + \square} \\
&= \int_0^2 \frac{dx}{-x^2 + x + \frac{1}{4} - \square - 4} \\
&= -\int_0^2 \frac{dx}{\left(x - \frac{1}{2}\right)^2 - (\square)^2} \\
&= \frac{1}{\sqrt{17}} \log \left( \frac{20 + 4\sqrt{17}}{20 - 4\sqrt{17}} \right)
\end{aligned}$$

$$\begin{aligned}
3) \quad & \int_0^1 \log \left( \frac{1}{x} - 1 \right) dx \\
&= \int_0^1 \log \left( \frac{1-x}{\square} \right) dx \dots\dots(1) \\
&= \int_0^1 \log \left( \frac{1-(1-x)}{\square} \right) dx
\end{aligned}$$

$$= \int_0^1 \log \left( \frac{\square}{1-x} \right) dx \dots\dots(2)$$

Adding (i) and (ii), we get

$$\begin{aligned}
2I &= \int_0^1 \log \left[ \frac{1-x}{x} \times \frac{x}{\square} \right] dx \\
&= \int_0^1 \log \square dx = \int_0^1 0 dx =
\end{aligned}$$

$$4) \quad \int_{-8}^8 \frac{x^5}{1-x^2} dx$$

$$f(x) = \frac{x^5}{1-x^2}$$

$$f(-x) = \frac{(-x)^5}{1-x^2} = \frac{\square}{1-x^2}$$

Hence  $f$  is  $\square$  function

$$\therefore \int_{-8}^8 \frac{x^5}{1-x^2} dx = \square$$





## Introduction

The theory of integration has a large variety of applications in Science and Engineering. In this chapter we shall use integration for finding the area of a bounded region. For this, we first draw the sketch (if possible) of the curve which encloses the region. For evaluation of area bounded by the certain curves, we need to know the nature of the curves and their graphs.

The shapes of different types of curves are discussed below.

### 7.1 Standard forms of parabola & their shapes

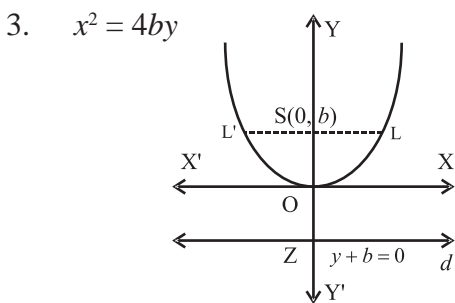
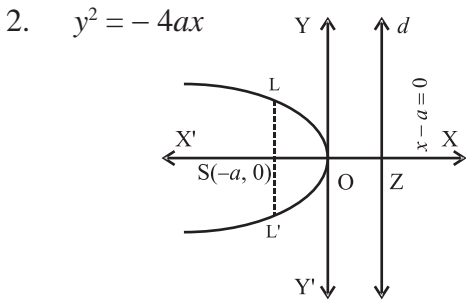
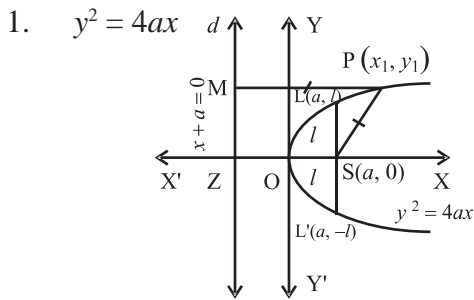

4.  $x^2 = -4by$

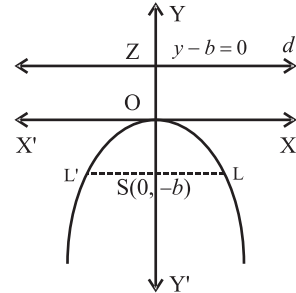

Fig. 7.1

### 7.2 Standard forms of ellipse

1)  $\frac{x^2}{a^2} + \frac{y^2}{b^2} = 1 \quad (a > b)$

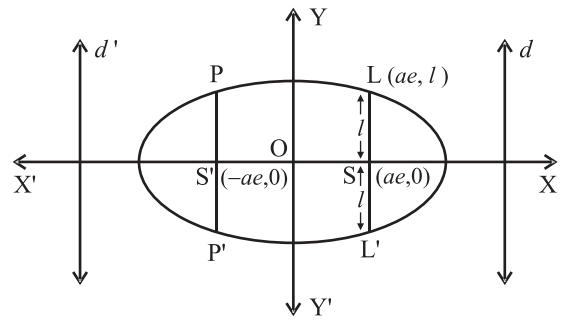

Fig. 7.2

2)  $\frac{x^2}{a^2} + \frac{y^2}{b^2} = 1 \quad (a < b)$

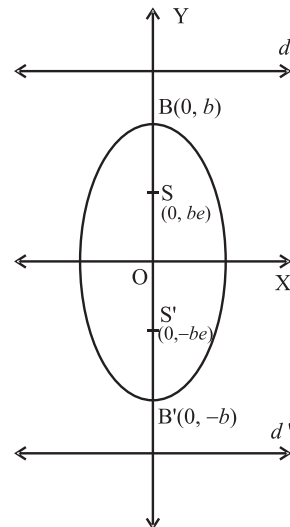

Fig.7.3

### 7.3 Area under the curve

To find the area under the curve, we state only formulae without proof.

- (1) The area "A" bounded by the curve  $y = f(x)$ , X-axis and bounded between the lines  $x = a$  and  $x = b$  (fig 7.4) is given by

A = Area of the region PRSQ

$$= \int_a^b y dx = \int_a^b f(x) dx$$

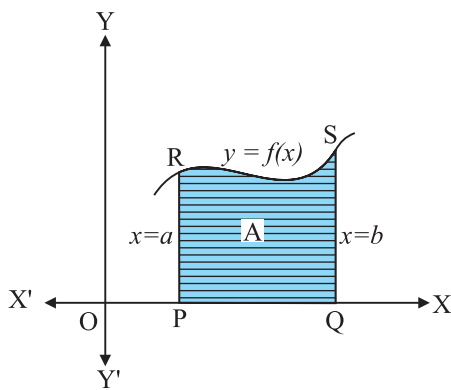

Fig. : 7.4

- (2) The area A bounded by the curve  $x = g(y)$ , Y-axis and bounded between the lines  $y = c$  and  $y = d$  (Fig. 7.5) is given by

$$A = \int_c^d x dy = \int_{y=c}^{y=d} g(y) dy$$

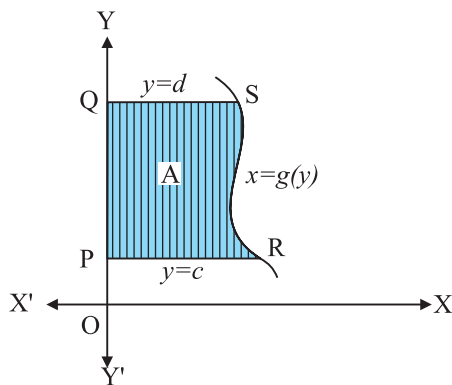

Fig. : 7.5

- (3) The area of the shaded region bounded by two curves  $y = f(x)$ ,  $y = g(x)$  as shown in fig. 7.6 is obtained by

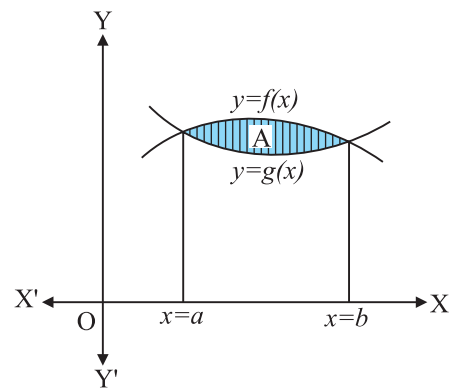

Fig. : 7.6

$$A = \left| \int_a^b f(x) dx - \int_a^b g(x) dx \right|$$

where the curve  $y = f(x)$  and  $y = g(x)$  intersect at points  $(a, f(a))$  and  $(b, f(b))$ .

#### Remarks:

- (i) If the curve under consideration is below the X-axis, then the area bounded by the curve, X-axis and lines  $x = a$ ,  $x = b$  is negative (fig. 7.7).

We consider the absolute value in this case.

$$\text{Thus, required area} = \left| \int_a^b f(x) dx \right|$$

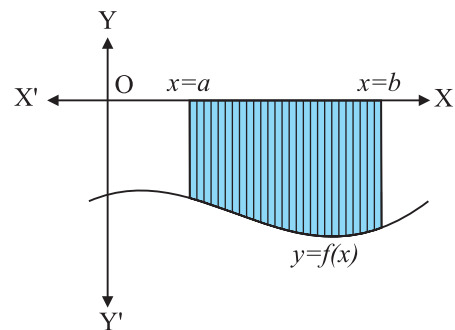

Fig. : 7.7

(ii) The area of the portion lying above the X-axis is positive.

(iii) If the curve under consideration lies above as well as below the X-axis, say  $A_1$  lies below X-axis and  $A_2$  lies above X-axis (as in Fig. 7.8), then A, the area of the region is given by,

$$A = A_1 + A_2$$

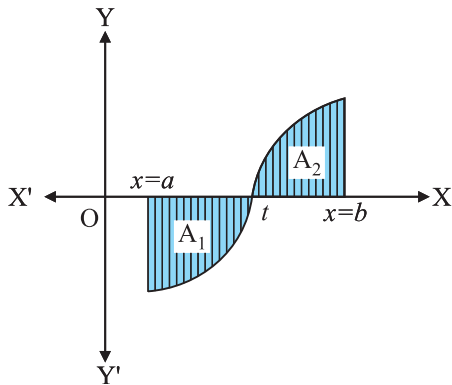

Fig. : 7.8

$$A_1 = \left| \int_a^t f(x) dx \right| \text{ and } A_2 = \int_t^b f(x) dx$$

Area A bounded by the curve  $y = 2x$ , X-axis and lines  $x = -2$  and  $x = 4$  is  $A_1 + A_2$ .

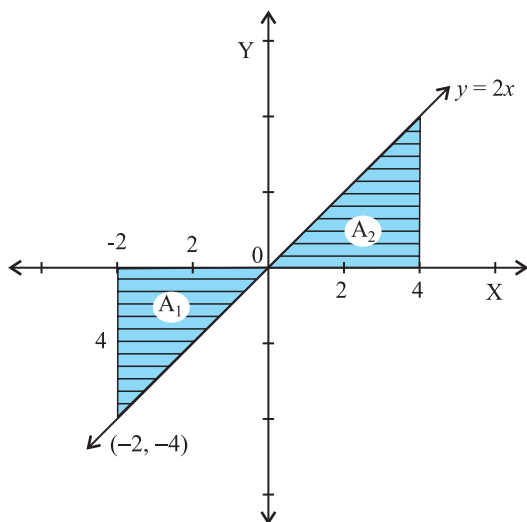

Fig. : 7.9

$$\begin{aligned} |A_1| &= \int_{x=-2}^0 y dx = \left| \int_{-2}^0 (2x) dx \right| \\ &= \left| 2 \cdot \int_{-2}^0 x dx \right| \\ &= \left| \left[ 2 \cdot \frac{x^2}{2} \right]_{-2}^0 \right| \\ &= |0 - 4| = 4 \text{ sq. units} \end{aligned}$$

$$A_2 = \int_0^4 2x dx = 2 \left[ \frac{x^2}{2} \right]_0^4 = (4^2 - 0^2) = 16 - 0 = 16$$

$$A = A_1 + A_2 = 4 + 16 = 20 \text{ sq. units}$$

### SOLVED EXAMPLES

1. Find the area of the regions bounded by the following curves, the X-axis and the given lines.

(a)  $y = x^2$ ,  $x = 1$ ,  $x = 3$

(b)  $y^2 = 4x$ ,  $x = 1$ ,  $x = 4$

(c)  $y = -2x$ ,  $x = -1$ ,  $x = 2$

**Solution:** Let A denote the required area in each case.

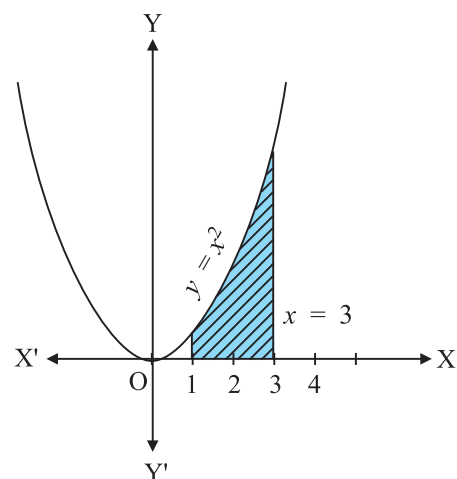

Fig. : 7.10

$$\begin{aligned}
 \text{(a) } A &= \int_1^3 y \, dx \\
 &= \int_1^3 x^2 \, dx \\
 &= \frac{1}{3} [x^3]_1^3 = \frac{1}{3} (3^3 - 1^3) = \frac{1}{3} (27 - 1) \\
 &= \frac{26}{3} \text{ sq. units}
 \end{aligned}$$

$$\begin{aligned}
 \text{(b) } A &= \int_1^4 y \, dx \\
 &= \int_1^4 2\sqrt{x} \, dx \\
 &= 2 \cdot \frac{2}{3} [x^{3/2}]_1^4 = \frac{4}{3} (4^{3/2} - 1^{3/2}) \\
 &= \frac{4}{3} (8 - 1) = \frac{28}{3} \text{ sq. units}
 \end{aligned}$$

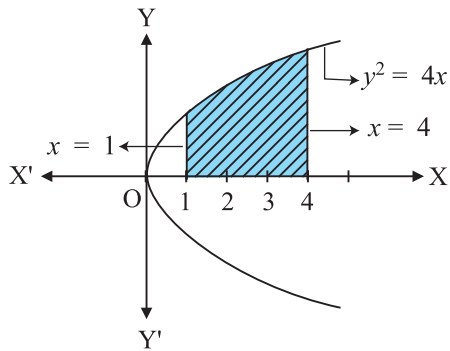

Fig. : 7.11

$$\text{(c) } A = (\text{Area below X-axis}) + (\text{Area above X-axis})$$

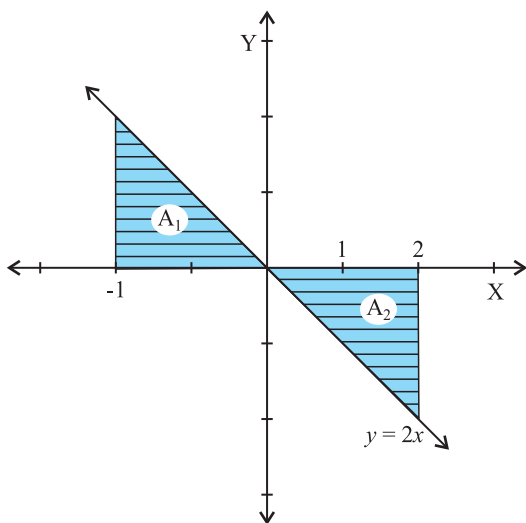

Fig. : 7.12

$$\text{Required area } A = A_1 + |A_2|$$

$$\begin{aligned}
 A &= \int_{-1}^0 (-2x) \, dx + \left| \int_0^2 (-2x) \, dx \right| \\
 &= \left[ -2 \frac{x^2}{2} \right]_{-1}^0 + \left[ \frac{2x^2}{2} \right]_0^2 \\
 &= [-x^2]_{-1}^0 + [x^2]_0^2 \\
 &= (0 + 1) + (4 - 0) \\
 &= 5 \text{ sq. units}
 \end{aligned}$$

$$A = 5 \text{ sq. units}$$

2. Find the area of the region bounded by the parabola  $y^2 = 16x$  and the line  $x = 4$ .

$$\text{Solution: } y^2 = 16x$$

$$\therefore y = \pm 4\sqrt{x}$$

$$\begin{aligned}
 \therefore A &= \text{Area POCP} + \text{Area QOCQ} \\
 &= 2(\text{Area POCP}) \text{ (why?)}
 \end{aligned}$$

$$\begin{aligned}
 &= 2 \int_0^4 y \, dx \\
 &= 2 \int_0^4 4\sqrt{x} \, dx
 \end{aligned}$$

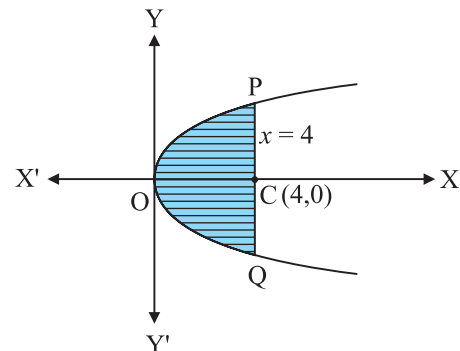

Fig. : 7.13

$$\therefore y \text{ lies above X-axis}$$

$$\begin{aligned}
 &= 8 \cdot \frac{2}{3} \cdot [x^{3/2}]_0^4 \\
 &= \frac{16}{3} \cdot [8] = \frac{128}{3} \text{ sq. units}
 \end{aligned}$$

3. Find the area of the region bounded by the curve  $x^2 = 16y$ ,  $y = 1$ ,  $y = 4$ , and the Y - axis lying in the first quadrant.

**Solution:** Required area =  $\int_1^4 x \cdot dy$

$$\begin{aligned} \therefore A &= \int_1^4 \sqrt{16y} \, dy = 4 \int_1^4 y^{1/2} \cdot dy \\ &= \left[ 4 \cdot \frac{2}{3} y^{3/2} \right]_1^4 = \frac{8}{3} \times 7 \\ &= \frac{56}{3} \text{ sq. units.} \end{aligned}$$

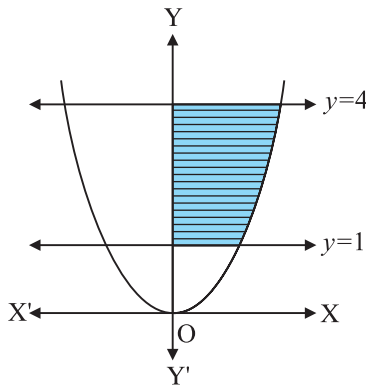

**Fig. : 7.14**

4. Find the area of the ellipse  $\frac{x^2}{a^2} + \frac{y^2}{b^2} = 1$ .  
Given

$$\left( \begin{array}{l} \int \sqrt{a^2 - x^2} \, dx = \frac{x}{2} \sqrt{a^2 - x^2} + \frac{a^2}{2} \sin^{-1} \left( \frac{x}{a} \right) \\ \sin^{-1}(1) = \frac{\pi}{2}, \sin^{-1}(0) = 0 \end{array} \right)$$

**Solution:** From the equation of ellipse

$$\frac{x^2}{a^2} + \frac{y^2}{b^2} = 1$$

$$\therefore \frac{y^2}{b^2} = 1 - \frac{x^2}{a^2}$$

$$y^2 = \frac{b^2}{a^2} (a^2 - x^2)$$

$$y = \pm \frac{b}{a} \sqrt{a^2 - x^2}$$

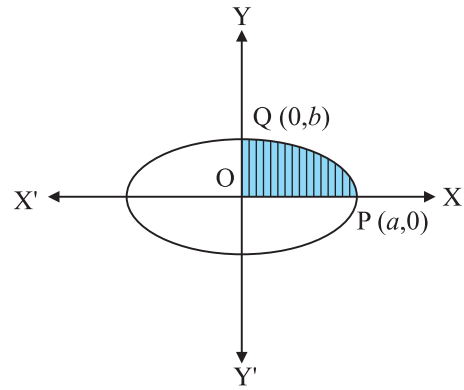

**Fig. : 7.15**

$$y = \frac{b}{a} \sqrt{a^2 - x^2}$$

$\therefore$  In first quadrant,  $y > 0$

$$\begin{aligned} \therefore A &= 4 \int_0^a y \, dx \\ &= 4 \int_0^a \frac{b}{a} \sqrt{a^2 - x^2} \, dx \\ &= \frac{4b}{a} \left[ \frac{x}{2} \sqrt{a^2 - x^2} + \frac{a^2}{2} \sin^{-1} \left( \frac{x}{a} \right) \right]_0^a \\ &= \frac{4b}{a} \left\{ \frac{a^2}{2} \sin^{-1}(1) - \frac{a^2}{2} \sin^{-1}(0) \right\} \\ &= \frac{4b}{a} \cdot \frac{a^2}{2} \cdot \frac{\pi}{2} - 0 \\ &= \pi ab \text{ sq. units.} \end{aligned}$$

5. Find the area of the region bounded by the curve  $y = x^2$  and the line  $y = 4$ .

**Solution:**

Equation of curve is  $y = x^2$  ..... (i)

and equation of line is  $y = 4$  .... (ii)

Because of symmetry,

Required area = 2 [Area in first quadrant]

$$A = 2 \int_0^4 x \cdot dy$$

$$\begin{aligned}
 &= 2 \int_0^4 \sqrt{y} \, dy \\
 &= 2 \times \frac{2}{3} [y^{3/2}]_0^4 = \frac{4}{3} (4^{3/2} - 0^{3/2}) \\
 &= \frac{4}{3} (8 - 0) = \frac{32}{3} \text{ sq. units.}
 \end{aligned}$$

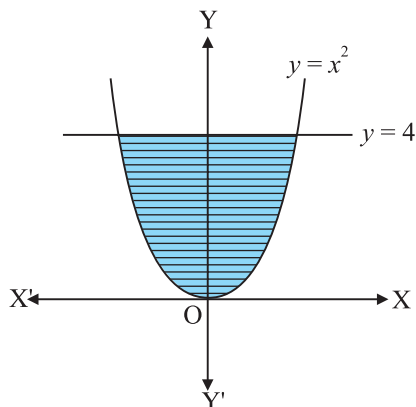

Fig. : 7.16

### EXERCISE 7.1

- Find the area of the region bounded by the following curves, the X-axis and the given lines:
  - $y = x^4$ ,  $x = 1$ ,  $x = 5$
  - $y = \sqrt{6x+4}$ ,  $x = 0$ ,  $x = 2$
  - $y = \sqrt{16-x^2}$ ,  $x = 0$ ,  $x = 4$
  - $2y = 5x + 7$ ,  $x = 2$ ,  $x = 8$
  - $2y + x = 8$ ,  $x = 2$ ,  $x = 4$
  - $y = x^2 + 1$ ,  $x = 0$ ,  $x = 3$
  - $y = 2 - x^2$ ,  $x = -1$ ,  $x = 1$
- Find the area of the region bounded by the parabola  $y^2 = 4x$  and the line  $x = 3$ .
- Find the area of circle  $x^2 + y^2 = 25$
- Find the area of ellipse  $\frac{x^2}{4} + \frac{y^2}{25} = 1$

### MISCELLANEOUS EXERCISE - 7

#### I) Choose the correct alternative.

- Area of the region bounded by the curve  $x^2 = y$ , the X-axis and the lines  $x = 1$  and  $x = 3$  is \_\_\_\_\_
  - $\frac{26}{3}$  sq. units
  - $\frac{3}{26}$  sq. units
  - 26 sq. units
  - 3 sq. units
- The area of the region bounded by  $y^2 = 4x$ , the X-axis and the lines  $x = 1$  &  $x = 4$  is \_\_\_\_\_
  - 28 sq. units
  - 3 sq. units
  - $\frac{28}{3}$  sq. units
  - $\frac{3}{28}$  sq. units
- Area of the region bounded by  $x^2 = 16y$ ,  $y = 1$  &  $y = 4$  and the Y-axis. lying in the first quadrant is \_\_\_\_\_
  - 63 sq. units
  - $\frac{3}{56}$  sq. units
  - $\frac{56}{3}$  sq. units
  - $\frac{63}{7}$  sq. units
- Area of the region bounded by  $y = x^4$ ,  $x = 1$ ,  $x = 5$  and the X-axis is \_\_\_\_\_
  - $\frac{3142}{5}$  sq. units
  - $\frac{3124}{5}$  sq. units
  - $\frac{3142}{3}$  sq. units
  - $\frac{3124}{3}$  sq. units
- Using definite integration area of circle  $x^2 + y^2 = 25$  is \_\_\_\_\_
  - $5\pi$  sq. units
  - $4\pi$  sq. units
  - $25\pi$  sq. units
  - 25 sq. units

**II. Fill in the blanks.**

- 1) Area of the region bounded by  $y = x^4$ ,  $x = 1$ ,  $x = 5$  and the X-axis is \_\_\_\_\_
- 2) Using definite integration area of the circle  $x^2 + y^2 = 49$  is \_\_\_\_\_
- 3) Area of the region bounded by  $x^2 = 16y$ ,  $y = 1$ ,  $y = 4$  and the Y-axis lying in the first quadrant is \_\_\_\_\_
- 4) The area of the region bounded by the curve  $x^2 = y$ , the X-axis and the lines  $x = 3$  and  $x = 9$  is \_\_\_\_\_
- 5) The area of the region bounded by  $y^2 = 4x$ , the X-axis and the lines  $x = 1$  &  $x = 4$  is \_\_\_\_\_

**III) State whether each of the following is True or False.**

- 1) The area bounded by the curve  $x = g(y)$ , Y-axis and bounded between the lines  $y = c$  and  $y = d$  is given by  $\int_c^d x \, dy = \int_{y=c}^{y=d} g(y) \, dy$
- 2) The area bounded by two curves  $y = f(x)$ ,  $y = g(x)$  and X-axis is  $\left| \int_a^b f(x) \, dx - \int_a^b g(x) \, dx \right|$
- 3) The area bounded by the curve  $y = f(x)$ , X-axis and lines  $x = a$  and  $x = b$  is  $\left| \int_a^b f(x) \, dx \right|$
- 4) If the curve, under consideration, is below the X-axis, then the area bounded by curve, X-axis and lines  $x = a$ ,  $x = b$  is positive.
- 5) The area of the portion lying above the X-axis is positive.

**IV) Solve the following.**

- 1) Find the area of the region bounded by the curve  $xy = c^2$ , the X-axis, and the lines  $x = c$ ,  $x = 2c$ .
- 2) Find the area between the parabolas  $y^2 = 7x$  and  $x^2 = 7y$ .

- 3) Find the area of the region bounded by the curve  $y = x^2$  and the line  $y = 10$ .
- 4) Find the area the ellipse  $\frac{x^2}{16} + \frac{y^2}{9} = 1$ .
- 5) Find the area of the region bounded by  $y = x^2$ , the X-axis and  $x = 1$ ,  $x = 4$ .
- 6) Find the area of the region bounded by the curve  $x^2 = 25y$ ,  $y = 1$ ,  $y = 4$  and the Y-axis.
- 7) Find the area of the region bounded by the parabola  $y^2 = 25x$  and the line  $x = 5$ .

**Activities**

**From the following information find the area of the shaded regions.**

1)

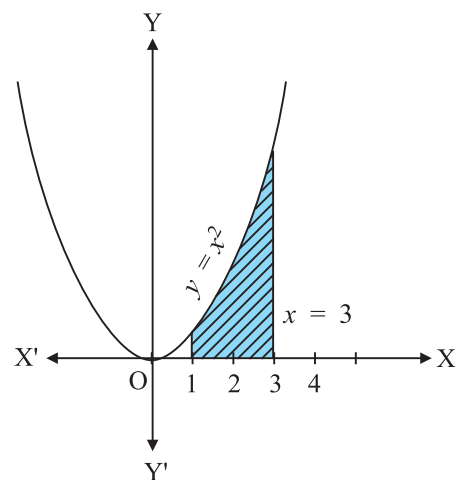

2)

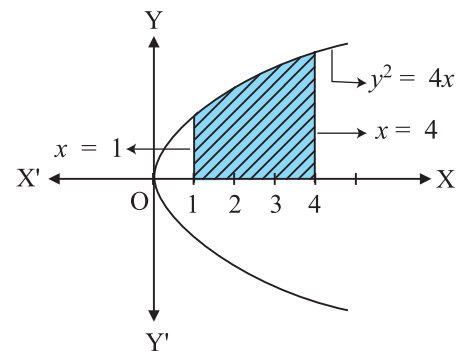



3) Given :  $y^2 = 16x$

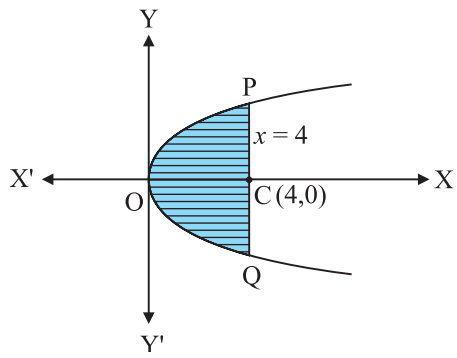

5)

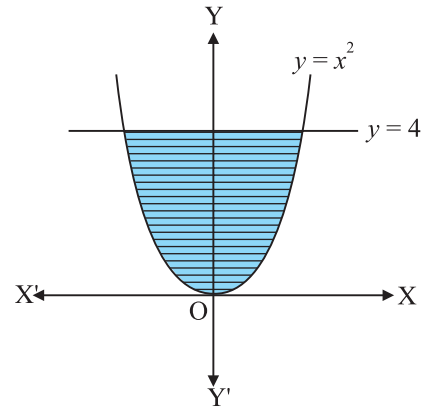

4) Given :  $x^2 = 16y$

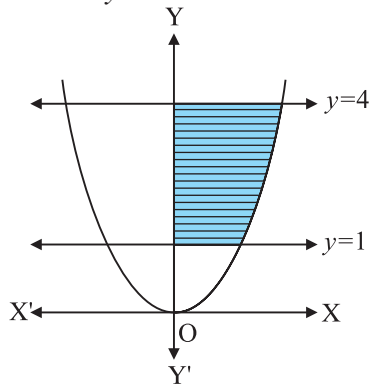

## 8

## Differential Equations and Applications



## Let's Study

- Differential Equation
- Ordinary differential equation
- Order and degree of a differential equation
- Solution of a differential equation
- Formation of a differential equation
- Applications of differential equations



## Let's Recall

- Independent variable
- Dependent variable
- Equation
- Derivatives
- Integration



## Let's Learn

## 8.1 Differential Equations:

**Definition:** An equation involving dependent variable(s), independent variable and derivative(s) of dependent variable(s) with respect to the independent variable is called a differential equation.

For example :

$$1) \quad \frac{dy}{dx} + y = x$$

$$2) \quad x^2 \frac{d^2y}{dx^2} + x \frac{dy}{dx} + y = 0$$

$$3) \quad \frac{d^2y}{dt^2} = 2t$$

$$4) \quad r \frac{dr}{d\theta} + e^\theta = 8$$

$$5) \quad \sqrt{1 + \frac{dy}{dx}} = \frac{d^2y}{dx^2}$$

$$6) \quad x dx + y dy = 0$$

## 8.1.1 Ordinary differential equation

A differential equation in which the dependent variable, say  $y$ , depends only on one independent variable, say  $x$ , is called an ordinary differential equation.

## 8.1.2 Order of a differential equation

It is the order of the highest order derivative occurring in the differential equation.

$$\frac{dy}{dx} + y = x \text{ is of order 1}$$

$$x^2 \frac{d^2y}{dx^2} + x \frac{dy}{dx} + y = 0 \text{ is of order 2}$$

$$\left(\frac{d^2y}{dx^2}\right)^2 + x \frac{dy}{dx} = 2y \text{ is of order 2}$$

$$\frac{2dy}{dx} = e^x \text{ is of order 1}$$

## 8.1.3 Degree of a differential equation

It is the power of the highest order derivative when all the derivatives are made free from fractional indices and negative sign, if any.

For example -

$$1) \quad x^2 \left(\frac{d^2y}{dx^2}\right)^1 + x \frac{dy}{dx} + y = 0$$

In this equation, the highest order derivative is  $\frac{d^2y}{dx^2}$  and its power is one. Therefore this

equation has degree one.

$$2) \quad \frac{d^2y}{dx^2} = \sqrt[3]{1 + \left(\frac{dy}{dx}\right)^2}$$

In this equation, the highest order derivative is  $\frac{d^2y}{dx^2}$  but to determine the degree of this equation, first we have to remove the cube root by raising both sides to the power 3.

$$\left(\frac{d^2y}{dx^2}\right)^3 = 1 + \left(\frac{dy}{dx}\right)^2 \quad \therefore \text{the degree of this}$$

equation is 3.

$$3) \quad \frac{dy}{dx} = \frac{2x+7}{\frac{dy}{dx}}$$

The equation can be written as

$$\left(\frac{dy}{dx}\right)^2 = 2x+7. \text{ Now highest order derivative is}$$

$\frac{dy}{dx}$  and its power is two. Hence the equation has degree two.

### We have learnt:

To find the degree of the differential equation, make all the derivatives free from fractional indices and negative sign, if any.

### 8.1.4 Solution of a Differential Equation:

A function of the form  $y = f(x) + c$  which satisfies the given differential equation is called the solution of the differential equation.

Every differential equation has two types of solutions: 1) General and 2) Particular

#### 1) General Solution:

A solution of the differential equation in which the number of arbitrary constants is equal to order of differential equation is called a general solution.

#### 2) Particular Solution:

A solution of the differential equation which can be obtained from the general solution by giving particular values to the arbitrary constants is called a particular solution.

### SOLVED EXAMPLES

- 1) Verify that the function  $y = ae^x + be^{-2x}$ ,  $a, b \in \mathbb{R}$  is a solution of the differential equation  $\frac{d^2y}{dx^2} + \frac{dy}{dx} = 2y$ .

**Solution:** Consider the function

$$y = ae^x + be^{-2x} \quad \dots\dots\dots \text{(I)}$$

Differentiating both sides of equation I with respect to  $x$ , we get

$$\frac{dy}{dx} = ae^x - 2be^{-2x} \quad \dots\dots\dots \text{II and}$$

Differentiating both sides of equation II with respect to  $x$ , we get

$$\frac{d^2y}{dx^2} = ae^x + 4be^{-2x} \quad \dots\dots\dots \text{III}$$

$$\begin{aligned} \text{Now, L.H.S} &= \frac{d^2y}{dx^2} + \frac{dy}{dx} \\ &= (ae^x + 4be^{-2x}) + (ae^x - 2be^{-2x}) \\ &\qquad\qquad\qquad \text{(from II and III)} \\ &= 2ae^x + 2be^{-2x} \\ &= 2(ae^x + be^{-2x}) = 2y \text{ (from I)} \\ &= \text{R.H.S.} \end{aligned}$$

Therefore, the given function is a general solution of the given differential equation.

- 2) Verify that the function  $y = e^{-x} + ax + b$ , where  $a, b \in \mathbb{R}$  is a solution of the differential equation  $e^x \left(\frac{d^2y}{dx^2}\right) = 1$

**Solution:**  $y = e^{-x} + ax + b \dots\dots\dots \text{I}$

Differentiating both sides of equation I with respect to  $x$ , we get

$$\therefore \frac{dy}{dx} = -e^{-x} + a \dots\dots\dots \text{II}$$

Differentiating both sides of equation II with respect to  $x$ , we get

$$\frac{d^2y}{dx^2} = e^{-x}$$

$$\begin{aligned} \text{Consider L.H.S.} &= e^x \frac{d^2y}{dx^2} = e^x (e^{-x}) \\ &= e^0 = 1 = \text{R.H.S.} \end{aligned}$$

Therefore, the given function is a general solution of the given differential equation.

### EXERCISE 8.1

1. Determine the order and degree of the following differential equations.

i)  $\frac{d^2x}{dt^2} + \left(\frac{dx}{dt}\right)^2 + 8 = 0$

ii)  $\left(\frac{d^2y}{dx^2}\right)^2 + \left(\frac{dy}{dx}\right)^2 = a^x$

iii)  $\frac{d^4y}{dx^4} + \left[1 + \left(\frac{dy}{dx}\right)^2\right]^3$

iv)  $(y''')^2 + 2(y'')^2 + 6y' + 7y = 0$

v)  $\sqrt{1 + \frac{1}{\left(\frac{dy}{dx}\right)^2}} = \left(\frac{dy}{dx}\right)^{3/2}$

vi)  $\frac{dy}{dx} = 7 \frac{d^2y}{dx^2}$

vii)  $\left(\frac{d^3y}{dx^3}\right)^{1/6} = 9$

2. In each of the following examples, verify that the given function is a solution of the corresponding differential equation.

	Solution	D.E.
i)	$xy = \log y + k$	$y'(1 - xy) = y^2$
ii)	$y = x^n$	$x^2 \frac{d^2y}{dx^2} - n \times \frac{xdy}{dx} + n y = 0$

iii)	$y = e^x,$	$\frac{dy}{dx} = y$
iv)	$y = 1 - \log x$	$x^2 \frac{d^2y}{dx^2} = 1$
v)	$y = ae^x + be^{-x}$	$\frac{d^2y}{dx^2} = y$
vi)	$ax^2 + by^2 = 5$	$xy \frac{d^2y}{dx^2} + x \left(\frac{dy}{dx}\right)^2 = y \cdot \frac{dy}{dx}$

### 8.1.5 Formation of a differential equation:

#### By eliminating arbitrary constants

If the order of a differential equation is  $n$ , differentiate the equation  $n$  times to eliminate arbitrary constants.

#### SOLVED EXAMPLES

1. Form the differential equation of the line having  $x$ -intercept 'a' and  $y$ -intercept 'b'.

**Solution:** The equation of a line is given by,

$$\frac{x}{a} + \frac{y}{b} = 1 \dots\dots\dots \text{I}$$

Differentiating equation I with r. t.  $x$  we get,

$$\frac{1}{a} + \frac{1}{b} \frac{dy}{dx} = 0, \therefore \frac{1}{b} \frac{dy}{dx} = -\frac{1}{a}$$

$$\therefore \frac{dy}{dx} = \frac{-b}{a} \dots\dots\dots \text{II}$$

Differentiating equation II with r. t.  $x$  we get,  $\frac{d^2y}{dx^2} = 0$  is the required differential equation.

2. Obtain the differential equation from the relation  $Ax^2 + By^2 = 1$ , where A and B are constant.

**Solution:** The given equation is

$$Ax^2 + By^2 = 1 \dots\dots\dots \text{I}$$

Differentiating equation I twice with respect to  $x$ , we get,

$$2Ax + 2By \frac{dy}{dx} = 0$$

$$Ax + By \frac{dy}{dx} = 0 \quad \dots\dots\dots \text{II and}$$

$$A + B \left( y \frac{d^2y}{dx^2} + \left( \frac{dy}{dx} \right)^2 \right) = 0 \quad \dots\dots\dots \text{III}$$

since the equations I, II & III are consistent in A and B,

$$\therefore \begin{vmatrix} x^2 & y^2 & 1 \\ x & y \frac{dy}{dx} & 0 \\ 1 & y \frac{d^2y}{dx^2} + \left( \frac{dy}{dx} \right)^2 & 0 \end{vmatrix} = 0$$

$$\therefore \left\{ x \left[ y \frac{d^2y}{dx^2} + \left( \frac{dy}{dx} \right)^2 \right] - 1 \times y \cdot \frac{dy}{dx} \right\} = 0$$

$$\therefore xy \frac{d^2y}{dx^2} + x \left( \frac{dy}{dx} \right)^2 - y \frac{dy}{dx} = 0$$

is the required differential equation.

3. Form the differential equation whose general solution is  $x^3 + y^3 = 4ax$

**Solution:** Given equation is

$$x^3 + y^3 = 4ax \quad \dots\dots\dots \text{I}$$

Since the given equation contains only one arbitrary constant, the required differential equation will be of order one.

Differentiating equation I with respect to  $x$ , we get,

$$3x^2 + 3y^2 \frac{dy}{dx} = 4a \quad \dots\dots\dots \text{II}$$

To eliminate  $a$  from the equations I & II, substitute the value of  $4a$  from equation II in I

$$x^3 + y^3 = x \left( 3x^2 + 3y^2 \frac{dy}{dx} \right)$$

$$x^3 + y^3 = 3x^3 + 3xy^2 \frac{dy}{dx}$$

$$\text{that is } 2x^3 - y^3 + 3xy^2 \frac{dy}{dx} = 0.$$

is the required differential equation.

**We have learnt:**

To form a differential equation by eliminating arbitrary constants, if 'n' arbitrary constants are present in the given equation then differentiate the given equation 'n' times.

**EXERCISE 8.2**

1. Obtain the differential equation by eliminating arbitrary constants from the following equations.
  - i)  $y = Ae^{3x} + B.e^{-3x}$
  - ii)  $y = c_2 + \frac{c_1}{x}$
  - iii)  $y = (c_1 + c_2x) e^x$
  - iv)  $y = c_1e^{3x} + c_2e^{2x}$
  - v)  $y^2 = (x + c)^3$
2. Find the differential equation by eliminating arbitrary constants from the relation  $x^2 + y^2 = 2ax$
3. Form the differential equation by eliminating arbitrary constants from the relation  $bx + ay = ab$ .
4. Find the differential equation whose general solution is  $x^3 + y^3 = 35ax$ .
5. Form the differential equation from the relation  $x^2 + 4y^2 = 4b^2$ .

**8.2.1 Solution of a Differential Equation:**

**Variable Separable Method.**

Sometimes, a differential equation of first order and first degree can be written in the form  $f(x) dx + g(y) dy = 0 \dots\dots\dots \text{I}$

where  $f(x)$  and  $g(y)$  are functions of  $x$  and  $y$  respectively.

This is said to be Variable Separable form, whose solution is obtained by integrating equation I and is given by

$\int f(x)dx + \int g(y) dy = c$ , where  $c$  is the constant of integration.

Now, we solve some examples using variable separable method.

### SOLVED EXAMPLES

1. Solve the differential equation  $\frac{dy}{dx} = \frac{1+y}{1+x}$

**Solution :** Separating the variables, the given equation can be written as,

$$\frac{dy}{1+y} = \frac{dx}{1+x}$$

Integrating both sides we get,

$$\int \frac{dy}{1+y} = \int \frac{dx}{1+x} + c$$

$$\log(1+y) = \log(1+x) + \log c$$

$$\log\left(\frac{1+y}{1+x}\right) = \log c$$

$$\therefore \frac{1+y}{1+x} = c$$

2. Solve the differential equation  $3e^x dx + (1 + e^x) dy = 0$

**Solution :** Given equation is

$$3e^x dx + (1 + e^x) dy = 0$$

This equation can be written as

$$\frac{3e^x}{1+e^x} dx + dy = 0$$

Integrating both sides we get,

$$\int \frac{3e^x}{1+e^x} dx + \int 1 dy = 0$$

$$\therefore 3 \log(1 + e^x) + y = c$$

3. Solve  $y - x \frac{dy}{dx} = 0$

**Solution:** Given equation is  $y - x \frac{dy}{dx} = 0$ .

Separating the variables we get,

$$\frac{dx}{x} = \frac{dy}{y} \text{ Integrating both sides we get,}$$

$$\int \frac{dx}{x} = \int \frac{dy}{y}$$

$$\log x = \log y + \log c$$

$$\log x - \log y = \log c$$

$$\log(x/y) = \log c \therefore \frac{x}{y} = c$$

**Note -** When variables are not separated we use the method of substitution

### SOLVED EXAMPLES

1. Solve

$(2x - 2y + 3) dx - (x - y + 1) dy = 0$ , hence find the particular solution if  $x = 0, y = 1$ .

**Solution :** The given equation is

$$(2x - 2y + 3) dx - (x - y + 1) dy = 0$$

$$(x - y + 1) dy = (2x - 2y + 3) dx$$

$$\frac{dy}{dx} = \frac{2x - 2y + 3}{x - y + 1} = \frac{2(x - y) + 3}{x - y + 1}$$

This equation cannot be written in variable separable form.

Use the method of substitution.

Put  $x - y = t$

$$\therefore \frac{dt}{dx} = 1 - \frac{dy}{dx} \therefore \frac{dy}{dx} = 1 - \frac{dt}{dx}$$

Using these in given equation we get,

$$1 - \frac{dt}{dx} = \frac{2t + 3}{t + 1}$$

$$1 - \frac{2t + 3}{t + 1} = \frac{dt}{dx}$$

$$\frac{dt}{dx} = \frac{t+1-2t-3}{t+1} = \frac{-t-2}{t+1}$$

$$\frac{t+1}{t+2} dt = -dx$$

Integrating we get,  $\int \frac{t+1}{t+2} dt = -\int 1 dx$

$$= \int \frac{(t+2)-1}{t+2} dt = \int -1 dx + c$$

$$= \int \left(1 - \frac{1}{t+2}\right) dt = \int -1 dx + c$$

$$t - \log(t+2) = -x + c,$$

Resubstituting the value of t, we get,

$$x - y - \log(x-y+2) = -x + c$$

$$2x - y - \log(x - y + 2) = c \dots\dots\dots I$$

which is the required general solution.

To determine the particular solution

we have  $x = 0$  and  $y = 1$ , Substitute in I

$$2(0) - 1 - \log(0 - 1 + 2) = c,$$

$$c = -1$$

$2x - y - \log(x - y + 2) + 1 = 0$  is the particular solution.

**We have learnt:**

To solve a differential equation of first order and first degree, separate the variables and integrate the equation.

**EXERCISE 8.3**

1. Solve the following differential equations

i)  $\frac{dy}{dx} = x^2y + y$

ii)  $\frac{d\theta}{dt} = -k(\theta - \theta_0)$

iii)  $(x^2 - yx^2) dy + (y^2 + xy^2) dx = 0$

iv)  $y^3 - \frac{dy}{dx} = x \frac{dy}{dx}$

2. For each of the following differential equations find the particular solution.

i)  $(x - y^2x)dx - (y + x^2y) dy = 0,$   
when  $x = 2, y = 0$

ii)  $(x + 1) \frac{dy}{dx} - 1 = 2e^{-5},$   
when  $y = 0, x = 1$

iii)  $y(1 + \log x) dx/dy - x \log x = 0,$   
when  $x = e, y = e^2.$

iv)  $\frac{dy}{dx} = (4x + y + 1),$  when  $y = 1, x = 0$

**8.3.1 Homogeneous Differential Equation:**

**Definition :** A differential equation  $f(x, y) dx + g(x, y) dy = 0$  is said to be Homogeneous Differential Equation if  $f(x, y)$  and  $g(x, y)$  are homogeneous functions of the same degree.

**For example:**

- 1)  $x^3dx + y^3dy = 0$  is homogeneous differential equation because  $x^3$  and  $y^3$  are homogeneous functions of the same degree.
- 2)  $x^2ydx + 8y^3dy = 0$  is homogeneous differential equation because  $x^2y$  and  $y^3$  are homogeneous functions of the same degree.

**8.3.2 Solution of Homogeneous Differential Equation:**

Method to solve Homogeneous Differential Equation:

To solve homogeneous differential equation

$$f(x,y)dx + g(x,y) dy = 0, \dots\dots\dots$$

we write it as

$$\frac{dy}{dx} = \frac{f(x, y)}{g(x, y)} \dots\dots\dots II$$

To solve this equation we substitute

$$y = t x$$

$$\frac{dy}{dx} = t + x \frac{dt}{dx}$$

Then equation II is converted into variable separable form and hence it can be solved.

**Let's note :** After solving equation II, resubstitution  $t = \frac{y}{x}$  will give the required solution of the given equation.

### SOLVED EXAMPLES

1. Solve :  $\left(1 + 2e^{\frac{x}{y}}\right) dx + 2e^{\frac{x}{y}} \left(1 - \frac{x}{y}\right) dy = 0$

**Solution:** The given equation can be written as

$$\frac{dy}{dx} = \frac{1 + 2e^{\frac{x}{y}}}{-2e^{\frac{x}{y}} \left(1 - \frac{x}{y}\right)}$$

This is Homogeneous Differential Equation

To solve it, substitute  $y = tx$

differentiating with respect to  $x$  we get,

$$\frac{dy}{dx} = t + x \frac{dt}{dx}$$

equation I can be written as

$$\begin{aligned} t + x \frac{dt}{dx} &= -\frac{1 + 2e^{\frac{1}{t}}}{2e^{\frac{1}{t}} \left(1 - \frac{1}{t}\right)} \\ x \frac{dt}{dx} &= -\frac{1 + 2e^{\frac{1}{t}}}{2e^{\frac{1}{t}} \left(1 - \frac{1}{t}\right)} - t \\ &= \frac{-(1 + 2e^{\frac{1}{t}} + (t-1)2e^{\frac{1}{t}})}{2e^{\frac{1}{t}} \left(1 - \frac{1}{t}\right)} \\ &= -\frac{(1 + 2te^{\frac{1}{t}})}{2e^{\frac{1}{t}} \left(1 - \frac{1}{t}\right)} \\ \therefore \frac{2e^{\frac{1}{t}} \left(1 - \frac{1}{t}\right)}{1 + 2te^{\frac{1}{t}}} dt &= -\frac{dx}{x} \end{aligned}$$

Integrating both sides, we get

$$\begin{aligned} \int \frac{2e^{\frac{1}{t}} (1 - 1/t)}{1 + 2te^{\frac{1}{t}}} dt &= -\int \frac{dx}{x} \\ \log [1 + 2t (e^{1/t})] + \log x &= \log c \\ \log [1 + 2t e^{1/t}] x &= \log c \\ x(1 + 2t e^{1/t}) &= c \end{aligned}$$

Resubstitute the value of  $t = \frac{y}{x}$  We get

$$\begin{aligned} x \left(1 + 2 \left(\frac{y}{x}\right) e^{\frac{x}{y}}\right) &= c, \\ x + 2ye^{x/y} &= c \end{aligned}$$

which is the required general solution.

2. Solve :  $(x^2 + y^2) dx - 2xy dy = 0$

**Solution:** The given equation can be written as

$$(x^2 + y^2) dx = 2xy dy$$

$$\frac{dy}{dx} = \frac{(x^2 + y^2)}{2xy} \dots\dots\dots I$$

To solve it, substitute  $y = tx$ .

Differentiating with respect to  $x$  we get,

$$\frac{dy}{dx} = t + x \frac{dt}{dx}$$

Equation I can be written as

$$\begin{aligned} t + x \frac{dt}{dx} &= \frac{(x^2 + t^2 x^2)}{2xtx} = \frac{x^2(1+t^2)}{2x^2 t} = \frac{1+t^2}{2t} \\ x \frac{dt}{dx} &= \frac{1+t^2}{2t} - t = \frac{1-t^2}{2t} \\ \therefore \frac{2t}{1-t^2} dt &= \frac{dx}{x} \end{aligned}$$

which is variable separable form.

Integrating both sides, we get,

$$\begin{aligned} \int \frac{2t}{1-t^2} dt &= \int \frac{dx}{x} \\ -\log (1 - t^2) &= \log x + \log c, \\ \log x + \log (1 - t^2) &= \log c \end{aligned}$$



$\log x(1 - t^2) = \log c$ ,  
 $x(1 - t^2) = c$ . Resubstitute the value of  $t = \frac{y}{x}$ ,  
 we get

$$x\left(1 - \frac{y^2}{x^2}\right) = c, \quad \frac{x(x^2 - y^2)}{x^2} = c$$

$$(x^2 - y^2) = cx$$

which is the required general solution.

**We have learnt :**

To solve a homogeneous differential equation, separate the variables using substitution  $\frac{y}{x} = t$  and integrate it.

**EXERCISE 8.4**

Solve the following differential equations.

1.  $x dx + 2y dy = 0$
2.  $y^2 dx + (xy + x^2) dy = 0$
3.  $x^2 y dx - (x^3 + y^3) dy = 0$
4.  $\frac{dy}{dx} + \frac{x - 2y}{2x - y} = 0$
5.  $(x^2 - y^2) dx + 2xy dy = 0$
6.  $xy \frac{dy}{dx} = x^2 + 2y^2$
7.  $x^2 \frac{dy}{dx} = x^2 + xy - y^2$

**8.4.1 Linear Differential Equation :**

**General Form**

The general form of a linear differential equation of first degree is

$$\frac{dy}{dx} + P y = Q \dots\dots\dots I,$$

where P and Q are functions of x only or constants.

**8.4.2 Solution of Linear Differential Equation:**

To solve  $\frac{dy}{dx} + P y = Q \dots\dots\dots I$

The solution of equation I is given by

$$y \cdot (\text{I.F.}) = \int Q \cdot (\text{I.F.}) dx + c$$

where I.F. (Integrating factor) =  $e^{\int p dx}$

**Let's Note:** If given equation is linear in x,

that is  $\frac{dx}{dy} + P \cdot x = Q$ , where P and Q are functions

of y only then its solution is given by

$$x \cdot (\text{I.F.}) = \int Q \cdot (\text{I.F.}) dy + c,$$

where I.F. =  $e^{\int p dy}$

Working rule to solve first order Linear Differential Equation.

- i. Write the equation in the form  $\frac{dy}{dx} + P y = Q$ .
- ii. Find I.F =  $e^{\int p dx}$
- iii. The solution of the given differential equation is  $y \cdot (\text{I.F.}) = \int Q \cdot (\text{I.F.}) dx + c$

**SOLVED EXAMPLES**

1. **Solve**  $\frac{dy}{dx} = x + y$

**Solution :** Given equation can be written

as  $\frac{dy}{dx} - y = x$

Here P = -1 and Q = x

$$\text{I.F.} = e^{\int p dx} = e^{\int -1 dx} = e^{-x}$$

Hence the solution of the given equation is given by

$$y \cdot e^{-x} = \int x \cdot e^{-x} dx + c$$

$$y \cdot e^{-x} = \frac{x e^{-x}}{-1} - \int \frac{e^{-x}}{-1} dx + c$$

$$y \cdot e^{-x} = -e^{-x} (x + 1) + c$$

$$x + y + 1 = c e^x$$

2. **Solve**  $\frac{dy}{dx} + \frac{y}{x} = x^3 - 3$

**Solution :** Given equation is of the type.

$$\frac{dy}{dx} + P y = Q,$$

where  $P = \frac{1}{x}$  and  $Q = x^3 - 3$

$$\text{I.F.} = e^{\int P dx} = e^{\int \frac{1}{x} dx} = e^{\log x} = x$$

The solution of the above equation is given by

$$y \cdot (\text{I.F.}) = \int Q \cdot (\text{I.F.}) dx + c$$

$$y \cdot x = \int (x^3 - 3) \cdot x dx + c$$

$$xy = \int (x^4 - 3x) dx + c$$

$$xy = \frac{x^5}{5} - \frac{3x^2}{2} + c, \text{ which is the solution of}$$

the given differential equation.

**We have learnt:**

To solve first order Linear Differential Equation

i. write the equation in the form  $\frac{dy}{dx} + P y = Q$ .

ii. Find I.F. =  $e^{\int P dx}$

iii) The solution of the given differential equation is  $y \cdot (\text{I.F.}) = \int Q \cdot (\text{I.F.}) dx + c$

**EXERCISE 8.5**

Solve the following differential equations

i.  $\frac{dy}{dx} + y = e^{-x}$

ii.  $\frac{dy}{dx} + y = 3$

iii.  $x \frac{dy}{dx} + 2y = x^2 \log x$

iv.  $(x + y) \frac{dy}{dx} = 1$

v.  $y dx + (x - y^2) dy = 0$

vi.  $\frac{dy}{dx} + 2xy = x$

vii.  $(x + a) \frac{dy}{dx} = -y + (a)$

viii.  $dr + (2r)d\theta = 8d\theta$

**8.5.1 Applications of Differential Equations**

**1) Population Growth and Growth of Bacteria.**

If the population (P) increases at time t then the rate of change of P is proportional to the population present at that time.

$$\text{This is } \frac{dp}{dt} \propto p, \quad \frac{dp}{dt} = kp$$

where k is the constant of proportionality.

$$\text{Integrating } \int \frac{dp}{p} = \int k dt + c$$

$$\log P = kt + c$$

$$\therefore P = e^{kt+c} = a \cdot e^{kt} \text{ where } e^c = a,$$

which gives the population at any time t.

**SOLVED EXAMPLES**

1. Bacteria increase at the rate proportional to the number of bacteria present. If the original number N doubles in 3 hours, find in how many hours the number of bacteria will be 4N.

**Solution:** Let x be the number of bacteria at time t. Since the rate of increase of x is proportional to x, the differential equation

$$\text{can be written as } \frac{dx}{dt} \propto x$$

$\frac{dx}{dt} = kx$ , where k is constant of proportionality. Integrating we get,

$$\int \frac{dx}{x} = k \int 1 \cdot dt + c$$

Solving this differential equation we get,

$$\log x = kt + c,$$

$$x = a e^{kt}, \text{ where } a = e^c \dots\dots\dots \text{I}$$

given that when  $t = 0, x = N$ .

From equation I we get  $N = a \cdot 1,$

$$a = N, \quad x = N e^{kt} \dots\dots\dots \text{II}$$

Also when  $t = 3, x = 2N,$

$$\text{From equation II, we have } 2N = N e^{3k}$$

$$e^{3k} = 2 \text{ i.e. } e^k = 2^{1/3} \quad \text{III}$$

Now we have to find out  $t$  when  $x = 4N$

From equation II, we get  $4N = N e^{kt}$

$$4 = e^{kt}, \quad 2^2 = 2^{t/3}, \quad t/3 = 2, \quad t = 6.$$

Hence number of bacteria will be  $4N$  in 6 hours.

2. The population of a country doubles in 60 years, in how many years will it be triple when the rate of increase is proportional to the number of inhabitants

(given  $\log_2 3 = 1.5894$ )

### Solution:

Let  $P$  be the population at time  $t$ .

Since the rate of increase of  $P$  is proportional to  $P$  itself, the differential equation can be

written as  $\frac{dp}{dt} \propto p$

$$\frac{dp}{dt} = kp$$

where  $k$  is the constant of proportionality

$$\text{Integrating } \left[ \int \frac{dp}{p} = \int k dt \right],$$

$$\therefore \log P = kt + c \dots\dots\dots(1)$$

i)  $t = 0, P = N$  from I

we get  $\log N = 0 + c, c = \log N$

ii) when  $t = 60, P = 2N,$

$$\log 2N = 60k + \log N$$

$$\log 2N - \log N = 60k$$

$$\log \frac{2N}{N} = 60k, k = \frac{\log 2}{60}$$

iii) Now  $P = 3N, t = ?$

from (I)  $\log P = \frac{\log 2}{60}t + \log N$

$$\log 3N - \log N = t \frac{\log 2}{60}$$

$$\frac{\log 3}{\log 2} \times 60 = t,$$

$$\therefore t = 1.5894 \times 60 = 95.36 \text{ years.}$$

### We have learnt :

#### For growth

If the population ( $P$ ) increases at time  $t$  then the rate of change in  $P$  is proportional to

the population present at that time  $\frac{dp}{dt} \propto p$ .

$\frac{dp}{dt} = kP$ , where  $k$  is the constant of proportionality. Integrating  $\int \frac{dp}{p} = \int k dt$ ,

we get  $\log P = kt + c, P = e^{kt+c} = a \cdot e^{kt}$   
(where  $e^c = a$ )

### Radio Active Decay:

We know that the radio active substances like radium, uranium etc. disintegrate with time. It means the mass of the substance decreases with time.

The rate of disintegration of such elements is proportional to the amount present at that time.

If  $x$  is the amount of radioactive material present at time  $t$  then

$$\frac{dx}{dt} = -kx, \text{ where } k \text{ is the constant of}$$

proportionality and  $k \neq 0$ . The negative sign appears because  $x$  decreases as  $t$  increases.

Integrating we get,

$$\int \frac{dx}{x} = - \int k dt + c$$

$$\log x = -kt + c, x = e^{-kt+c} = e^{-kt} \cdot e^c$$

$$x = a \cdot e^{-kt}, \text{ (where } a = e^c) \dots\dots\dots \text{I}$$

If  $x_0$  is the initial amount of radio active substance at time  $t = 0$ , then from equation I

$$x_0 = a \cdot 1, a = x_0,$$

$$x = x_0 \cdot e^{-kt} \dots\dots\dots \text{II}$$

### SOLVED EXAMPLES

- The rate of disintegration of a radio active element at time  $t$  is proportional to its mass at that time. The original mass of 800 gm will disintegrate into its mass of 400 gm after 5 days. Find the mass remaining after 30 days.

### Solution:

If  $x$  is the amount of material present at time  $t$  then

$\frac{dx}{dt} = -kt$ , where  $k$  is constant of proportionality

$$\int \frac{dx}{x} = -\int k dt + c$$

$$\log x = -kt + c$$

$$x = e^{-kt+c} = e^{-kt} \cdot e^c$$

$$x = a \cdot e^{-kt}, \text{ where } a = e^c. \dots\dots\dots \text{I}$$

Given when  $t = 0$ ,  $x = 800$

From I we get,  $800 = a \cdot 1 = a$

$$x = 800 e^{-kt} \dots\dots\dots \text{II}$$

when  $t = 5$ ,  $x = 400$  from II

$$400 = 800 e^{-5k}$$

$$e^{-5k} = \frac{1}{2}$$

Now we have to find  $x$ , when  $t = 30$

From II we have

$$x = 800 e^{-30k} = 800 (e^{-5k})^6$$

$$= 800 \left(\frac{1}{2}\right)^6 = \frac{800}{64} = 12.5$$

The mass remaining after 30 days will be 12.5 mg.

### We have learnt :

#### For decay

If  $x$  is the amount of any decaying material present at time  $t$  then

$\frac{dx}{dt} = -kx$ , where  $k$  is constant of proportionality and  $k \neq 0$ . The negative sign appears because  $x$  decreases as  $t$  increases,

Integrating we get

$$\int \frac{dx}{x} = \int -k dt \text{ that is } \log x = -kt + c$$

$$\therefore \log x = -kt + c, x = e^{-kt+c} = e^{-kt} \cdot e^c$$

$$\therefore x = a \cdot e^{-kt}, \text{ where } a = e^c.$$

### EXERCISE 8.6

1. In a certain culture of bacteria, the rate of increase is proportional to the number present. If it is found that the number doubles in 4 hours, find the number of times the bacteria are increased in 12 hours.
2. If the population of a town increases at a rate proportional to the population at that time. If the population increases from 40 thousands to 60 thousands in 40 years, what will be the population in another 20 years?

$$\text{(Given : } \sqrt{\frac{3}{2}} = 1.2247)$$

3. The rate of growth of bacteria is proportional to the number present. If initially, there were 1000 bacteria and the number doubles in 1 hour, find the number of bacteria after  $5/2$  hours.

$$\text{(Given : } \sqrt{2} = 1.414)$$

4. Find the population of a city at any time  $t$  given that the rate of increase of population is proportional to the population at that instant and that in a period of 40 years the population increased from 30000 to 40000.

5. The rate of depreciation  $\frac{dv}{dt}$  of a machine

is inversely proportional to the square of  $t + 1$ , where  $V$  is the value of the machine  $t$  years after it was purchased. The initial value of the machine was Rs. 8,00,000 and its value decreased Rs. 1,00,000 in the first year.

Find its value after 6 years.



### Let's Remember

1. An equation which involves polynomials of differentials of dependent variables with respect to the independent variable is called a differential equation.

## MISCELLANEOUS EXERCISE - 8

2. A differential equation in which the dependent variable, say  $y$ , depends only on one independent variable, say  $x$ , is called an ordinary differential equation.
3. Order of a differential equation : It is the order of highest-order derivative occurring in the differential equation.
4. Degree of a differential equation : It is the power of the highest-order derivative when all the derivatives are made free from negative and / or fractional indices, if any.
5. **(i) General Solution :** A solution of differential equation in which the number of arbitrary constants is equal to the order of differential equation is called a general solution.  
**(ii) Particular Solution :** A solution of a differential equation which can be obtained from the general solution by giving particular values to the arbitrary constants.
6. Order and degree of a differential equation are always positive integers.
7. Homogeneous Differential Equation: Definition : A differential equation  $f(x,y)dx + g(x,y)dy = 0$  is said to be Homogeneous Differential Equation if  $f(x,y)$  and  $g(x,y)$  are homogeneous functions of the same degree.
8. The general form of a linear differential equation of the first order is  $\frac{dy}{dx} = Py + Q$  (I), Where P and Q are functions of  $x$  only or constants.  
The solution of the above equation (I) is given by  $y \cdot (\text{I.F.}) = \int Q \cdot (\text{I.F.}) dx + c$  where I.F. (Integrating factor) =  $e^{\int P dx}$
9. If given equation is not linear in  $y$  that is  $\frac{dy}{dx} + P \cdot x = Q$  then its solution is given by  $x \cdot (\text{I.F.}) = \int Q \cdot (\text{I.F.}) dy + c$ , where I.F. =  $e^{\int P dy}$ .

### I) Choose the correct alternative.

1. The order and degree of  $\left(\frac{dy}{dx}\right)^3 - \frac{d^3y}{dx^3} + ye^x$  are respectively.
  - a) 3,1
  - b) 1,3
  - c) 3,3
  - d) 1,1
- 2) The order and degree of  $\left[1 + \left(\frac{dy}{dx}\right)^3\right]^{\frac{2}{3}} = 8 \frac{d^3y}{dx^3}$  are respectively
  - a) 3,1
  - b) 1,3
  - c) 3,3
  - d) 1,1
- 3) The differential equation of  $y = k_1 + \frac{k_2}{x}$  is
  - a)  $\frac{d^2y}{dx^2} + 2\frac{dy}{dx} = 0$
  - b)  $x \frac{d^2y}{dx^2} + 2\frac{dy}{dx} = 0$
  - c)  $\frac{d^2y}{dx^2} - 2\frac{dy}{dx} = 0$
  - d)  $x \frac{d^2y}{dx^2} - 2\frac{dy}{dx} = 0$
4. The differential equation of  $y = k_1 e^x + k_2 e^{-x}$  is
  - a)  $\frac{d^2y}{dx^2} - y = e^x$
  - b)  $\frac{d^2y}{dx^2} + \frac{dy}{dx} = 0$
  - c)  $\frac{d^2y}{dx^2} + y \frac{dy}{dx} = 0$
  - d)  $\frac{d^2y}{dx^2} + y = 0$
5. The solution of  $\frac{dy}{dx} = 1$  is
  - a)  $x + y = c$
  - b)  $xy = c$
  - c)  $x^2 + y^2 = c$
  - d)  $y - x = c$
- 6) The solution of  $\frac{dy}{dx} + \frac{x^2}{y^2} = 0$  is
  - a)  $x^3 + y^3 = 7$
  - b)  $x^2 + y^2 = c$
  - c)  $x^3 + y^3 = c$
  - d)  $x + y = c$

- 7) The solution of  $x \frac{dy}{dx} = y \log y$  is
- $y = ae^x$
  - $y = be^{2x}$
  - $y = be^{-2x}$
  - $y = e^{ax}$
- 8) Bacterial increases at the rate proportional to the number present. If the original number M doubles in 3 hours, then the number of bacteria will be 4M in
- 4 hours
  - 6 hours
  - 8 hours
  - 10 hours
- 9) The integrating factor of  $\frac{dy}{dx} + y = e^{-x}$  is
- $x$
  - $-x$
  - $e^x$
  - $e^{-x}$
- 10) The integrating factor of  $\frac{d^2y}{dx^2} - y = e^x$  is  $e^{-x}$  then its solution is
- $ye^{-x} = x + c$
  - $ye^x = x + c$
  - $ye^x = 2x + c$
  - $ye^{-x} = 2x + c$

## II. Fill in the blanks.

- The order of highest derivative occurring in the differential equation is called ..... of the differential equation.
- The power of the highest ordered derivative when all the derivatives are made free from negative and / or fractional indices if any is called ..... of the differential equation.
- A solution of differential equation which can be obtained from the general solution by giving particular values to the arbitrary constants is called ..... solution.
- Order and degree of a differential equation are always ..... integers.
- The integrating factor of the differential equation  $\frac{dy}{dx} - y = x$  is .....
- The differential equation by eliminating arbitrary constants from  $bx + ay = ab$  is .....

## III State whether each of the following is True or False.

- The integrating factor of the differential equation  $\frac{dy}{dx} - y = x$  is  $e^{-x}$ .
- Order and degree of a differential equation are always positive integers
- The degree of a differential equation is the power of the highest ordered derivative when all the derivatives are made free from negative and / or fractional indices if any.
- The order of highest derivative occurring in the differential equation is called degree of the differential equation.
- The power of the highest ordered derivative when all the derivatives are made free from negative and / or fractional indices if any is called order of the differential equation.
- The degree of the differential equation  $e^{\frac{dy}{dx}} = \frac{dy}{dx} + c$  is not defined.

## IV. Solve the following.

- Find the order and degree of the following differential equations:
  - $\left[ \frac{d^3y}{dx^3} + x \right]^{3/2} = \frac{d^2y}{dx^2}$
  - $x + \frac{dy}{dx} = 1 + \left( \frac{dy}{dx} \right)^2$
- Verify  $y = \log x + c$  is a solution of the differential equation  $x \frac{d^2y}{dx^2} + \frac{dy}{dx} = 0$ .
- Solve the differential equations
  - $\frac{dy}{dx} = 1 + x + y + xy$
  - $e^{dy/dx} = x$
  - $dr = a r d\theta - \theta dr$
  - Find the differential equation of family of curves  $y = e^x (ax + bx^2)$  where A and B are arbitrary constant.

4) Solve  $\frac{dy}{dx} = \frac{x+y+1}{x+y-1}$

when  $x = \frac{2}{3}$  and  $y = \frac{1}{3}$

5) Solve  $ydx - xdy = -\log x dx$

6) Solve  $y \log y \frac{dx}{dy} + x - \log y = 0$

7) Solve  $(x+y)dy = a^2 dx$

8) Solve  $\frac{dy}{dx} + \frac{2}{x}y = x^2$

9) The rate of growth of population is proportional to the number present.

If the population doubled in the last 25 years and the present population is 1 lac, when will the city have population 4,000,000?

10) The resale value of a machine decreases over a 10 year period at a rate that depends on the age of the machine. When the machine is  $x$  years old, the rate at which its value is changing is ₹ 2200  $(x - 10)$  per year. Express the value of the machine as a function of its age and initial value. If the machine was originally worth ₹ 1,20,000 how much will it be worth when it is 10 years old?

11)  $y^2 dx + (xy + x^2)dy = 0$

12)  $x^2 ydx - (x^3 + y^3)dy = 0$

13)  $yx \frac{dy}{dx} = x^2 + 2y^2$

14)  $(x + 2y^3) \frac{dy}{dx} = y$

15)  $ydx - xdy + \log x dx = 0$

16)  $\frac{dy}{dx} = \log x$

17)  $y \log y \frac{dy}{dx} = \log y - x$

### Activities

1) Complete the following activity.

The equation  $\frac{dy}{dx} - y = 2x$  is of the form

Where  $P =$   and,  $Q =$

$\therefore$  I.F. =  $e^{\int p dx} =$

$\therefore$  the solution of the linear differential equation is

$y$   =  $\int 2x$  (I.F.)  $dx + c$ .

$\therefore ye^{-x} = \int 2x$    $dx + c$

$ye^{-x} = 2 \int x$    $dx$

=  $2 \{x[e^{-x} dx - \int$    $dx \frac{d}{dx}$    $dx] + c$

=  $2 \{x \frac{e^{-x}}{\square} - \int \frac{e^{-x}}{\square} .1 dx$

$\therefore e^{-x} y = -2xe^{-x} + 2 \int$    $dx + c_1$

$e^{-x} y = -2xe^{-x} + 2$    $+ c_2$

$y +$    $+ \frac{2}{e^{-x}}$  =  $ce^x$  is the required general solution of the given differential equation.

2) Verify  $y = a + \frac{b}{x}$  is a solution of

$x \frac{d^2 y}{dx^2} + 2 \frac{dy}{dx} = 0$

$y = a + \frac{b}{x}$

$\frac{dy}{dx} =$

$\frac{d^2 y}{dx^2} =$

**Consider**  $x \frac{d^2 y}{dx^2} + 2 \frac{dy}{dx}$

=  $x$    $+ 2$

=

Hence  $y = a + \frac{b}{x}$  is a solution of



# Answers

## 1. Mathematical logic

### Exercise : 1.1

Sentences (ii), (x), (xiii), (xvi), (xvii), (xviii), (xix), (xx), (xxiv) are statements and their truth value is T.

Sentences (i), (v), (vi), (xi), (xii), (xiv), (xv) are statements and their truth value is F.

Sentences (iii), (iv), (vii), (viii), (ix), (xxi), (xxii), (xxiii), (xxv) are not statements in logic.

### Exercise : 1.2

- 1) i)  $p \vee q$     ii)  $p \wedge q$     iii)  $p \vee q$   
 iv)  $p \wedge q$     v)  $p \wedge q$

- 2) truth values are  
 i) F    ii) F    iii) F  
 iv) T

### Exercise : 1.3

- 1) i) Some men are not animals.  
 ii)  $-3$  is not a natural number.  
 iii) Nagpur is capital of Maharashtra  
 iv)  $2 + 3 = 5$

- 2) Truth values are  
 i) F    ii) F    iii) T

### Exercise : 1.4

- 1) i)  $p \rightarrow q$     ii)  $\sim P$     iii)  $\sim P \wedge q$   
 iv)  $p \leftrightarrow \sim q$     v)  $p \leftrightarrow q$     vi)  $p \rightarrow q$

- 2) Truth values are  
 i) T    ii) F    iii) F  
 iv) T    v) T
- 3) Truth values are  
 i) F    ii) T    iii) T  
 iv) F    v) T    vi) F
- 4) Truth values are  
 i) F    ii) T    iii) F
- 5) i) He swims if and only if water is not warm.  
 ii) It is not true that he swims or water is warm.  
 iii) If water is warm then he swims.  
 iv) water is warm and he does not swim.

### Exercise : 1.5

- 1) i)  $\exists x \in \mathbb{N}$ , such that  $x^2 + 3x - 10 = 0$   
 It is true statement, since  $x = 2 \in \mathbb{N}$  satisfies it.
- ii)  $\exists x \in \mathbb{N}$ , such that  $3x - 4 < 9$   
 It is a true statement, since  $x = 2, 3, 4 \in \mathbb{N}$  satisfy  $3x - 4 < 9$ .
- iii)  $\forall n \in \mathbb{N}$ ,  $n^2 \geq 1$   
 It is true statement, since all  $n \in \mathbb{N}$  satisfy it.
- iv)  $\exists n \in \mathbb{N}$ , such that  $2n - 1 = 5$   
 It is true statement, since  $n = 3 \in \mathbb{N}$  satisfy  $2n - 1 = 5$ .
- v)  $\exists y \in \mathbb{N}$ , such that  $y + 4 > 6$   
 It is true statement, since  $y = 3, 4, \dots \in \mathbb{N}$  satisfy  $y + 4 > 6$ .



- v)  $\exists y \in \mathbb{N}$ , such that  $3y - 2 \leq 9$   
It is true statement, since  $y = 1, 2, 3, \dots \in \mathbb{N}$  satisfy it.

2) Truth value are

- i) F      ii) T      iii) F  
iv) F      v) F

**Exercise : 1.6**

- 1) i) TFFT      ii) FFTT  
iii) TTTTTTTT      iv) TTFTFTFT
- 2) i) tatology      ii) contradiction  
iii) contigency      iv) tautology

**Exercise : 1.7**

- 1) i)  $(p \wedge q) \wedge r$   
ii)  $\sim (p \wedge q) \vee [p \wedge \sim (q \vee \sim r)]$   
iii)  $p \wedge (q \wedge r) \equiv (p \wedge q) \wedge r$   
iv)  $\sim (p \vee q) \equiv \sim p \wedge \sim q$
- 2) i) 13 is a prime number or India is a democratic country.  
ii) Karina is very good and everybody likes her.  
iii) Radha or Sushmita can not read Urdu.  
iv) A number is real number or the square of the numbers is non negative.

**Exercise : 1.8**

- 1) i) Some stars are shining and it is night.  
ii)  $\exists n \in \mathbb{N}$ , such that  $n + 1 \leq 0$   
iii)  $\forall n \in \mathbb{N}$ ,  $(n^2 + 2)$  is not odd number  
iv) All continuous functions are not differentiable.
- 2) i)  $(p \wedge \sim r) \vee \sim q$   
ii)  $(\sim p \wedge \sim q) \wedge \sim r$   
iii)  $(p \vee \sim q) \vee (q \wedge r)$

- 3) i) Converse : If they do not drive the car then it snows.

Inverse : If it does not snow then they drive the car.

Contrapositive : If they drive the car then it does not snow.

- ii) Converse : If he will go to college then he studies.

Inverse : If he does not study, then he will not go to college.

Contrapositive : If he will not go to college then he does not study.

- 4) i)  $(p \wedge \sim q) \wedge (p \wedge \sim r)$   
ii)  $(p \wedge \sim q) \wedge r$   
iii)  $(p \wedge \sim q) \vee \sim r$

**Exercise : 1.10**

1) Venn diagrams.

- i) U : The set of all students  
S : The set of all hard working students.  
O : The set of all obedient students.

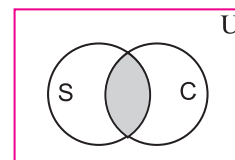

$S \cap O \neq \phi$

- ii) U : The set of closed geometrical figures in plane.

D : The set of all polygons.

F : The set of all circles.

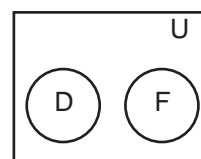

$D \cap F = \phi$

- iii) U : The set of all human beings.  
 T : The set of all teachers.  
 S : The set of all scholars.

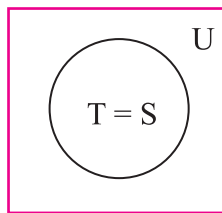

.....

- iv) U : The set of all quadrilaterals.  
 P : The set of all parallelograms.  
 R : The set of all rhombus.

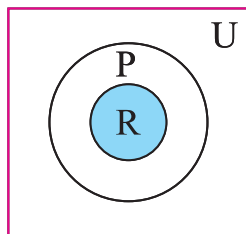

$$R \subset P$$

2) Venn diagrams

i)

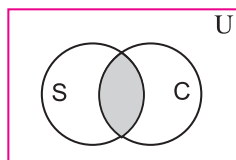

$$S \cap C \neq \phi$$

Where

- U : The set of all human beings.  
 S : The set of all share brokers.  
 C : The set of all chartered accountants.

ii)

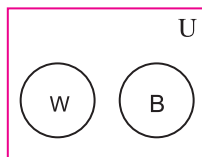

$$W \cap B = \phi$$

Where

- U : The set of all human beings.  
 W : The set of all wicket keepers.  
 B : The set of all bowlers.

3) i)

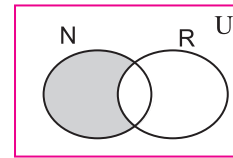

$$N - R \neq \phi$$

Where

- U : The set of all human beings.  
 N : The set of all non resident Indians.  
 R : The set of all rich people.

ii)

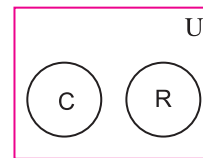

$$C \cap R = \phi$$

Where

- U : The set of all geometrical polygons.  
 C : The set of all circles.  
 R : The set of all rectangles.

iii)

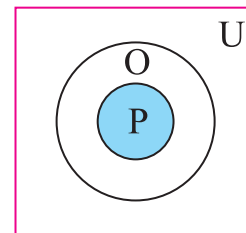

$$P \subset O$$

Where

- U : The set of all real numbers.  
 P : The set of all prime numbers and  $n \neq 2$ .  
 O : The set of all odd numbers.

## MISCELLANEOUS EXERCISE - 1

- I. 1) d    2) a    3) d    4) b  
 5) c    6) c    7) b    8) d  
 9) c    10) a    11) b    12) d  
 13) b    14) c    15) c

- II. i) Converse    ii)  $p \wedge q$     iii) F  
 iv) No men are animals    v) F  
 vi)  $\sim p \rightarrow \sim q$     vii) different  
 viii) If the problem is not easy then it is not challenging.  
 ix) T

- III. i) False    ii) True    iii) False  
 iv) False    v) False    vi) True  
 vii) True    viii) False    ix) False  
 x) True.

- IV. 1) sentence (i), (ii), (iv), (v), (vi), (ix), (x), (xi) are statements. in logic  
 sentence (iii), (vii), (viii), (xii), (xiii) are not statements in logic  
 2) sentence (ii), (iii), (iv), (vi), (vii), (ix) are statement and truth value of each is T.  
 Sentence (x) is a statement and its truth value is F.  
 Sentence (i), (v), (viii) are not statement.  
 3) i)  $p \wedge q$     ii)  $p \wedge q$     iii)  $p \leftrightarrow q$   
 iv)  $p \wedge q$     v)  $p \rightarrow q$     vi)  $p \leftrightarrow q$   
 vii)  $p \leftrightarrow q$     viii)  $p \leftrightarrow q$     ix)  $p \rightarrow q$   
 x)  $p \rightarrow q$     xi)  $\sim(p \wedge q)$     xii)  $q \rightarrow p$   
 xiii)  $\sim p$     xiv)  $p \rightarrow q$   
 4) i)  $p \wedge \sim q$     ii)  $p \rightarrow q$     iii)  $\sim(p \wedge q)$   
 iv)  $q \leftrightarrow p$   
 5) i) Sachin wins the match or he is the member of Rajya Sabha or Sachin is happy.

- ii) If Sachin wins the match then he is happy.  
 iii) Sachin does not win the match or he is the member of Rajya Sabha.  
 iv) If sachin wins the match, then he is the member of Rajyasabha or he is happy.  
 v) Sachin wins the match if and only if he is happy.  
 vi) Sachin wins the match and he is the member of Rajyasabha but he is not happy.  
 vii) It is false that sachin wins the match or he is the member of Rajyasabha but he is happy.

- 6) i) F    ii) T    iii) F  
 iv) T

- 7) i) T    ii) T    iii) F  
 iv) T

- 8) i) Demand does not fall or price does not increase.  
 ii) Price increase or demand does not falls.

- 9) i) F    ii) F    iii) F  
 iv) T    v) T

- 10) i)  $\Delta ABC$  is not equilateral and it is equiangular.  
 ii) Ramesh is not intelligent or he is not hard working.  
 iii) An angle is a right angle and it is not of measure  $90^\circ$ , or an angle is of measure  $90^\circ$  and it is a right angles.  
 iv) Kanchanganga is not in India or Everest is not in Nepal.  
 v)  $x \in (A \cap B)$  and  $x \notin A$  or  $x \notin B$ .

- ii) i) FTTF                      ii) FFFT  
 iii) TTTTTTTT    iv) FTTTFTTT  
 v) TFTFTTFF
- 13) i) tautology                      ii) contradiction  
 iii) contradiction                  iv) contingency  
 v) contradiction
- 15) i) Converse : If  $4 + 10 = 20$ , then  $2 + 5 = 10$   
 Inverse : If  $2 + 5 \neq 10$ , then  $4 + 10 \neq 20$   
 Contrapositive : If  $4 + 10 \neq 20$ , then  $2 + 5 \neq 10$
- ii) Converse : If a man is happy, then he is bachelor  
 Inverse : If a man is not bachelor, then he is not happy.  
 Contrapositive : If a man is not happy, then he is not bachelor.
- iii) Converse : If I do not prosper, then I do not work hard.  
 Inverse : If I work hard then I prosper.  
 Contrapositive : If I prosper then I work hard.
- 16) i)  $(p \vee \sim q) \wedge (\sim p \vee q) \equiv (p \wedge q) \vee \sim(p \vee q)$   
 ii)  $p \wedge (q \wedge r) \equiv \sim[(p \vee q) \wedge (r \wedge s)]$   
 iii) 2 is even number and 9 is a perfect square.
- 17) i) A quadrilateral is not a rhombus or it is not a square.  
 ii)  $10 - 3 \neq 7$  or  $10 \times 3 \neq 30$   
 iii) It does not rain or the principal declares a holiday.
- 18) i)  $(\sim p \vee q) \wedge (p \vee \sim q) \wedge (\sim p \vee \sim q)$   
 ii)  $(p \vee q) \vee r \equiv p \vee (q \vee r)$   
 iii)  $p \wedge (q \vee r) \equiv (p \wedge q) \vee (p \wedge r)$   
 iv)  $\sim(p \wedge q) \equiv \sim p \vee \sim q$

- 19) Statement (i) and (iii) are identical  
 Statement (ii) and iv) are identical
- 20) i) U : The set of all human being  
 A : The set of all men  
 B : The set of all mortal

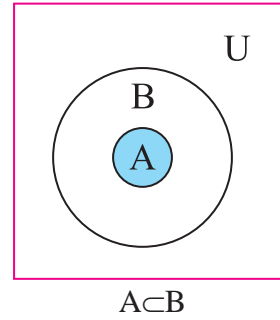

- ii) U : The set of all human beings.  
 X : The set of all persons.  
 Y : The set of all politician

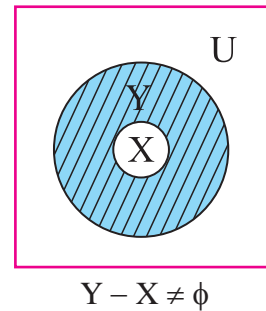

- iii) U : The set of all human beings.  
 X : The set of all members of the present Indian cricket.  
 Y : The set of all committed members of the present Indian cricket.

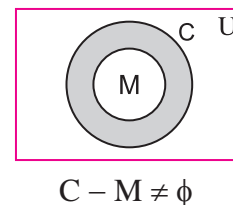

- iv) U : Set of all human beings.  
 C : Set of all child.  
 A : Set of all Adult.

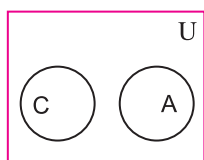

$$C \cap A = \phi$$

- 21) i) T      ii) F      iii) T  
iv) F

- 22) i) 7 is not prime number or Tajmahal is not in Agra  
ii)  $10 < 5$  or  $3 > 8$   
iii) I will have not tea and cofee.  
iv)  $\exists n \in \mathbb{N}$ , such that  $n + 3 \leq 9$   
v)  $\forall x \in \mathbb{A}$ ,  $x + 5 \geq 11$ .

## 2. Matrices

### Exercise : 2.1

1) i)  $A = \begin{bmatrix} 0 & \frac{1}{4} \\ \frac{1}{3} & 0 \\ 2 & \frac{1}{2} \end{bmatrix}$       ii)  $A = \begin{bmatrix} -2 & -5 \\ -1 & -4 \\ 0 & -3 \end{bmatrix}$

iii)  $A = \frac{1}{5} \begin{bmatrix} 8 & 27 \\ 27 & 64 \\ 64 & 125 \end{bmatrix}$

- 2) i) Upper Triangular Matrix  
ii) Column Matrix  
iii) Row Matrix  
iv) Scalar Matrix  
v) Lower Triangular Matrix  
vi) Diagonal Matrix  
vii) Identity Matrix

- 3) i) Singular Matrix  
ii) Singular Matrix  
iii) Non Singular Matrix  
iv) Non singular Matrix

- 4) i)  $k = \frac{-6}{7}$       ii)  $k = 6$   
ii)  $k = \frac{49}{8}$

### Exercise : 2.2

2)  $A - 2B + 6I = \begin{bmatrix} 5 & 4 \\ -3 & 23 \end{bmatrix}$

3)  $C = \begin{bmatrix} -10 & -1 & 1 \\ 7 & -9 & 3 \\ -4 & 6 & 2 \end{bmatrix}$

4)  $X = \begin{bmatrix} -1 & \frac{2}{5} \\ \frac{6}{5} & \frac{19}{5} \\ \frac{19}{5} & \frac{26}{5} \end{bmatrix}$

5)  $(A^T)^T = A$       6)  $(A^T)^T = A$

7)  $a = -4$ ,  $b = \frac{3}{5}$ ,  $c = -7$

8)  $x = \frac{-3}{2}$ ,  $y = 5i$ ,  $z = \sqrt{2}$

- 9) i)  $A = A^T \therefore A$  is a symmetric matrix,  
ii) Neither  $A = A^T$  nor  $A = -A^T \therefore A$  is neither symmetric nor skew symmetric matrix.  
iii)  $A = -A^T \therefore A$  is a skew symmetric matrix.

$$10) A = \begin{bmatrix} 0 & -1 & -2 \\ 1 & 0 & -1 \\ 2 & 1 & 0 \end{bmatrix}$$

$\therefore A$  is a skew symmetric matrix.

$$11) X = \begin{bmatrix} \frac{3}{8} & \frac{-1}{4} \\ \frac{-3}{8} & \frac{1}{2} \end{bmatrix}, Y = \begin{bmatrix} \frac{1}{8} & \frac{1}{4} \\ \frac{-1}{8} & \frac{1}{2} \end{bmatrix}$$

$$12) A = \begin{bmatrix} 3 & \frac{-14}{3} & \frac{-8}{3} \\ -2 & 1 & 3 \end{bmatrix},$$

$$B = \begin{bmatrix} 0 & \frac{-10}{3} & \frac{-16}{3} \\ 0 & 0 & 5 \end{bmatrix}$$

$$13) x = \frac{-1}{4}, y = \frac{9}{2}$$

$$14) a = 1, b = 0, c = \frac{2}{5}, d = \frac{9}{5}$$

15) i) Suresh book shop : Rs. 1050/- in Physics Rs. 305/- in Chemistry and Rs. 405/- in Maths.

Ganesh book shop : Rs. 350/- in Physics Rs. 445/- in Chemistry and Rs. 1295/- in Maths.

ii) The profit for Suresh book shop are Rs. 665/- in Physics Rs. 705.50/- in Chemistry and Rs. 890.50/- in Maths.

For Ganesh book shop are Rs. 700/- in Physics Rs. 750/- in Chemistry and Rs. 1020/- in Maths.

### Exercise : 2.3

$$1) \text{ i) } \begin{bmatrix} 6 & -12 & 9 \\ 4 & -8 & 6 \\ 2 & -4 & 3 \end{bmatrix} \quad \text{ii) } [8]$$

2)

$$AB = \begin{bmatrix} 2 & 1 & -1 \\ 13 & 2 & 14 \\ -6 & 3 & -1 \end{bmatrix} \text{ and } BA = \begin{bmatrix} 4 & -7 & 6 \\ -1 & -3 & 5 \\ 4 & 4 & 2 \end{bmatrix}$$

$\therefore AB \neq BA$

$$7) (A+I)(A-I) = \begin{bmatrix} 9 & 6 & 4 \\ 15 & 32 & -2 \\ 35 & -7 & 29 \end{bmatrix}$$

$$9) k = -7$$

$$11) a = 2, b = -1$$

$$12) k = 1$$

$$13) x = 19, y = 12$$

$$14) x = -3, y = 1, z = -1$$

$$15) \text{ Jay Rs. 104 and Ram Rs. 150}$$

### Exercise : 2.4

$$1) \text{ i) } A^T = \begin{bmatrix} 1 & -4 \\ 3 & 5 \end{bmatrix}$$

$$\text{ii) } A^T = \begin{bmatrix} 2 & -4 \\ -6 & 0 \\ 1 & 5 \end{bmatrix}$$

$$2) A = \begin{bmatrix} 0 & -2 & -4 \\ 2 & 0 & -2 \\ 4 & 2 & 0 \end{bmatrix} \text{ and } A^T = \begin{bmatrix} 0 & 2 & 4 \\ -2 & 0 & 2 \\ -4 & -2 & 0 \end{bmatrix}$$

$\therefore$  Both are skew symmetric.

$$6) C^T = \begin{bmatrix} -16 & 14 \\ -6 & -10 \end{bmatrix}$$

$$7) \text{ i) } \begin{bmatrix} 7 & 8 \\ -5 & 8 \\ 12 & -18 \end{bmatrix} \quad \text{ii) } \begin{bmatrix} 35 & -10 \\ 25 & 15 \\ -15 & 10 \end{bmatrix}$$

$$11) \text{ i) } \begin{bmatrix} 4 & \frac{1}{2} \\ \frac{1}{2} & -5 \end{bmatrix} + \begin{bmatrix} 0 & \frac{-5}{2} \\ \frac{5}{2} & 0 \end{bmatrix}$$

$$\text{ii) } \frac{1}{2} \begin{bmatrix} 6 & 1 & -5 \\ 1 & -4 & -4 \\ -5 & -4 & 4 \end{bmatrix} + \frac{1}{2} \begin{bmatrix} 0 & 5 & 3 \\ -5 & 0 & 6 \\ -3 & -6 & 0 \end{bmatrix}$$

$$9) \frac{1}{6} \begin{bmatrix} 4 & 4 & 2 \\ 11 & 8 & -5 \\ 10 & 10 & 2 \end{bmatrix} \quad 10) \begin{bmatrix} -\frac{1}{3} \\ -\frac{7}{3} \\ 2 \end{bmatrix}$$

### Exercise : 2.5

$$1) \text{ i) } \begin{bmatrix} 2 & 2 \\ 3 & -4 \end{bmatrix} \quad \text{ii) } \begin{bmatrix} 4 & 2 \\ -5 & 1 \end{bmatrix}$$

$$\text{iii) } \begin{bmatrix} 3 & 1 & -1 \\ 3 & 9 & 3 \\ -1 & 1 & 3 \end{bmatrix} \text{ and } \begin{bmatrix} 3 & -11 & -1 \\ 1 & -1 & 1 \\ -1 & 5 & 3 \end{bmatrix}$$

$$2) \begin{bmatrix} 1 & -1 & 2 \\ 0 & 1 & \frac{-1}{3} \\ 0 & 0 & \frac{-1}{3} \end{bmatrix}$$

$$3) \text{ i) } \begin{bmatrix} -8 & -5 \\ -2 & 1 \end{bmatrix} \quad \text{ii) } \begin{bmatrix} -3 & -1 & 5 \\ -1 & 19 & -21 \\ 22 & -12 & -2 \end{bmatrix}$$

$$4) \text{ i) } \begin{bmatrix} 5 & 3 \\ -3 & 2 \end{bmatrix} \quad \text{ii) } \begin{bmatrix} -3 & -1 & -11 \\ -12 & 3 & -9 \\ 6 & 2 & 1 \end{bmatrix}$$

$$5) \text{ i) } \begin{bmatrix} 1 & -1 \\ 2 & -3 \end{bmatrix} \quad \text{ii) } \frac{1}{18} \begin{bmatrix} 5 & 2 \\ -4 & 2 \end{bmatrix}$$

$$\text{iii) } \frac{1}{10} \begin{bmatrix} 10 & -10 & 2 \\ 0 & 5 & -4 \\ 0 & 0 & 2 \end{bmatrix}$$

$$6) \text{ i) } \frac{1}{5} \begin{bmatrix} 1 & 2 \\ 2 & -1 \end{bmatrix} \quad \text{ii) } \begin{bmatrix} 3 & -1 & 1 \\ -15 & 6 & -5 \\ 5 & -2 & 2 \end{bmatrix}$$

$$7) \frac{1}{6} \begin{bmatrix} 4 & -2 & 2 \\ -3 & 0 & 3 \\ 3 & 2 & -2 \end{bmatrix} \quad 8) \begin{bmatrix} 13 & 2 & -7 \\ -3 & -1 & 2 \\ -2 & 0 & 1 \end{bmatrix}$$

### Exercise : 2.6

$$1) \text{ i) } x=0, y=1 \quad \text{ii) } x=4, y=-3$$

$$\text{iii) } x=1, y=2, z=1$$

$$\text{iv) } x = \frac{5}{2}, y = \frac{-1}{2}, z = -1$$

$$2) \text{ i) } x = \frac{1}{2}, y = \frac{1}{2} \quad \text{ii) } x=1, y=2$$

$$\text{iii) } x=3, y=2, z=1$$

$$\text{iv) } x=-2, y=0, z=3$$

3) Cost price T.V. Rs. 3000 and cost price of V.C. Rs. 13000. Selling price of T.V. Rs. 4000 and Selling price of V.C.R. Rs. 13500.

4) Cost of one Economics book is Rs. 300, Cost of one Co-operation book is Rs. 60 and Cost of one Account book is Rs. 60.

### MISCELLANEOUS EXERCISE - 2

I. 1) c    2) b    3) d    4) c  
5) a    6) a    7) b    8) d  
9) c    10) a    11) b    12) b  
13) d    14) c    15) b

II. 1) Column    2)  $2 \times 3$     3) 2  
4) -1    5) 3    6) -2  
7) |A|    8) A    9) -1

$$10) \begin{bmatrix} a_1 & b_1 \\ a_2 & b_2 \end{bmatrix} \begin{bmatrix} x \\ y \end{bmatrix} = \begin{bmatrix} c_1 \\ c_2 \end{bmatrix}$$

- III. 1) True      2) False      3) True  
 4) False      5) False      6) False  
 7) False      8) False      9) False  
 10) True

$$\text{iv) } \begin{bmatrix} 3 & -1 & 1 \\ -15 & 6 & -5 \\ 5 & -2 & 2 \end{bmatrix}$$

IV. 1)  $k = \frac{15}{7}$       2)  $x = 3, y = 5, z = 5$

$$17) A^{-1} = \frac{1}{40} \begin{bmatrix} 19 & 5 & -27 \\ -2 & 10 & -14 \\ -3 & -5 & 19 \end{bmatrix}$$

$$4) A - 4B + 7I = \begin{bmatrix} 5 & -23 \\ 15 & 14 \end{bmatrix}$$

$$18) \text{ i) } x = \frac{26}{7}, y = \frac{30}{7}$$

$$9) a = \frac{-2}{7}, b = \frac{-2}{7}$$

$$\text{ii) } x = 3, y = 1, z = 2$$

$$\text{iii) } x = 2, y = -1, z = 1$$

$$10) A^3 = \begin{bmatrix} -9 & 22 \\ -11 & 13 \end{bmatrix}$$

$$19) \text{ i) } x = 4, y = -3$$

$$\text{ii) } x = \frac{-5}{7}, y = \frac{6}{7}, z = 2$$

$$\text{iii) } x = \frac{1}{6}, y = -\frac{1}{3}, z = \frac{5}{6}$$

$$11) x = -9, y = -3, z = 0$$

- 14) i) Shantaram    Kantaram  
 $\begin{pmatrix} \text{Rs.33000} & \text{Rs.39000} \\ \text{Rs.28000} & \text{Rs.31500} \\ \text{Rs.2e000} & \text{Rs.24000} \end{pmatrix}$  Rice  
 Wheat  
 Groundnut

- 20) Three number  $x = 1, y = 2, z = 3$

- ii) Shantaram    Kantaram  
 $\begin{pmatrix} \text{Rs.3000} & \text{Rs.3000} \\ \text{Rs.2000} & \text{Rs.1500} \\ \text{Rs.0} & \text{Rs.8000} \end{pmatrix}$  Rice  
 Wheat  
 Groundnut

- 15) i) Invertible      ii) Not Invertible  
 iii) Invertible      iv) Not Invertible

$$16) \text{ i) } \begin{pmatrix} \frac{3}{5} & \frac{1}{5} \\ -\frac{2}{5} & \frac{1}{5} \end{pmatrix} \quad \text{ii) } \begin{pmatrix} 4 & -1 \\ -7 & 2 \end{pmatrix}$$

$$\text{iii) } \begin{bmatrix} -\frac{2}{5} & 0 & \frac{3}{5} \\ -\frac{1}{5} & \frac{1}{5} & 0 \\ \frac{2}{5} & \frac{1}{5} & -\frac{2}{5} \end{bmatrix}$$

### 3. Differentiation

#### Exercise : 3.1

$$\text{I. 1) } \frac{1}{2} \left( x + \frac{1}{x} \right)^{-\frac{1}{2}} \left( 1 - \frac{1}{x^2} \right)$$

$$2) \frac{2x}{3} (a^2 + x^2)^{-\frac{2}{3}}$$

$$3) 9(5x^3 - 4x^2 - 8x)^8 (15x^2 - 8x - 8)$$

$$\text{II. 1) } \frac{1}{x \cdot \log x}$$

$$2) \frac{(40x^3 + 15x^2 - 6x)}{(10x^4 + 5x^3 - 3x^2 + 2)}$$

$$3) \frac{2ax + b}{ax^2 + bx + c}$$



III. 1)  $(10x-2)e^{5x^2-2x+4}$

2)  $a^{(1+\log x)} \log a \cdot \frac{1}{x}$

3)  $5^{(x+\log x)} \log 5 \cdot \left(1 + \frac{1}{x}\right)$

**Exercise : 3.2**

I. 1)  $\frac{1}{10+50x}$

2)  $\frac{x-4}{18x-71}$

3)  $\frac{1+x^2}{25x^2+2x+25}$

II. 1)  $\frac{e^x}{1-x}$

2)  $\frac{(x^2+1)^2}{1-4x-x^2}$

3)  $\frac{-(2x-10)^2}{68}$

**Exercise : 3.3**

I. 1)  $x^{x^{2x}} x^{2x} \log x \left[ 2(1+\log x) + \frac{1}{x \log x} \right]$

2)  $x^{e^x} e^x \left[ \frac{1}{x} + \log x \right]$

3)  $e^{x^x} x^x [1+\log x]$

II. 1)  $\left(1 + \frac{1}{x}\right)^x \left[ \log \left(1 + \frac{1}{x}\right) - \frac{1}{1+x} \right]$

2)  $(2x+5)^x \left[ \log(2x+5) + \frac{2x}{2x+5} \right]$

3)  $\frac{1}{3} \sqrt[3]{\frac{(3x-1)}{(2x+3)(5-x)^2}} \left[ \frac{3}{3x-1} - \frac{2}{2x+3} + \frac{2}{5-x} \right]$

III. 1)  $(\log x)^x \left[ \frac{1}{\log x} + \log(\log x) \right] \times x^{\log x} \left[ \frac{2 \log x}{x} \right]$

2)  $x^x(1+\log x) + a^x \log a$

3)  $10^{x^x} \cdot x^x \cdot \log 10(1+\log x) + 10^{x^{10}}$

$(10 \cdot x^9) \log 10 + 10^{10^x} \cdot 10^x (\log 10)^2$

**Exercise : 3.4**

I. 1)  $-\sqrt{\frac{y}{x}}$  2)  $-\frac{3x^2(1+4y)}{3y^2+4x^3}$

3)  $-\frac{3x^2+2xy+y^2}{x^2+2xy+3y^2}$

II. 1)  $-\frac{e^y+ye^x}{e^x+xe^y}$  2)  $\frac{\log x}{(1+\log x)^2}$

3)  $-\frac{y}{x}$

III. 1)  $\frac{y}{x}$  2)  $-\frac{y^2}{x^2}$

3)  $-e^{y-x}$

**Exercise : 3.5**

I. 1)  $\frac{1}{t}$  2)  $t^2$  3)  $\frac{4}{3} e^{t+5}$

II. 1)  $\frac{y \log 2}{2\sqrt{x}}$  2)  $\frac{2}{\sqrt{1+u^2}}$

3)  $x \cdot 5^x (\log 5)$

**Exercise : 3.6**

I. 1)  $-\frac{1}{4} x^{\frac{-3}{2}}$  2)  $20x^3$  3)  $56x^{-9}$

II. 1)  $e^x$  2)  $4e^{(2x+1)}$  3)  $0$

### MISCELLANEOUS EXERCISE - 3

I.

- 1) a    2) c    3) a    4) b    5) c  
6) b    7) b    8) a    9) d    10) c

II.

- 1) -1    2) y    3) x    4) y    5)  $\frac{1}{x}$

- 6)  $\frac{-1}{x^2}$     7)  $\frac{y^2}{y^2-1}$     8)  $axy$

- 9) y    10) my

III.

- 1) True    2) False    3) True  
4) False    5) True    6) False  
7) True    8) False

IV.

1)  $10(6x^3 - 3x^2 - 9x)^4(18x^2 - 6x - 9)$

2)  $\frac{4}{5}(3x^2 + 8x + 5)^{\frac{-1}{5}}(6x + 8)$

3)  $\frac{2 \log[\log(\log x)]}{x \log x \log(\log x)}$     4)  $\frac{1}{30 - 2x}$

5)  $-\frac{(2x-13)^2}{79}$     6)  $x^x \cdot (1 + \log x)$

7)  $2^{x^x} x^x \log 2 \cdot (1 + \log x)$

8)  $\sqrt{\frac{(3x-4)^3}{(x+1)^4(x+2)}} \cdot \frac{1}{2} \left[ \frac{9}{3x-4} - \frac{4}{x+1} - \frac{1}{x+2} \right]$

9)  $x^x(1 + \log x) + (7x-1)^x \left[ \log(7x-1) + \frac{7x}{7x-1} \right]$

10)  $\frac{-3(x^2 + y^2 + 2xy)}{(6xy + 3x^2 - 1)}$     11)  $\frac{-(y+3x^2)}{(2y+x)}$

12)  $\frac{x}{y} \left[ \frac{2-3xy^3}{2+3x^3y} \right]$     13)  $\frac{1}{t}$     14)  $\frac{1}{6\sqrt{t}} e^{(\sqrt{t}-3t)}$

15)  $\frac{2x}{a^x \cdot \log a \cdot (1+x^2)}$

16)  $\frac{e^{(4x+5)}}{10^{4x} \cdot \log 10}$

17)  $\frac{-1}{x^2}$

18)  $\frac{-1}{2at^3}$

19)  $e^x(x^2 + 4x + 2)$

### 4. Applications of Derivatives

#### Exercise : 4.1

- 1) i)  $5x - y - 2 = 0$ ;  $x + 5y - 16 = 0$   
ii)  $2x + 3y - 5$ ;  $3x - 2y - 1$   
iii)  $x + y = 2$ ;  $x - y = 0$   
2)  $4x - y + 7 = 0$  &  $x + 4y - 38 = 0$   
3)  $3x - y - 8 = 0$  &  $x + 3y + 14 = 0$

#### Exercise : 4.2

- 1) i) Increasing,  $x \in \mathbb{R} - \{2\}$   
ii) Increasing,  $x \in \mathbb{R}$ ,  $x \neq 0$   
iii) Decreasing,  $x \in \mathbb{R}$ ,  $x \neq 0$   
2) i)  $(-\infty, 2) \cup (3, \infty)$   
ii)  $x > -1$  i.e.  $(-1, \infty)$   
iii)  $(-\infty, -3) \cup (8, \infty)$   
3) i)  $-3 < x < 8$   
ii)  $-\infty < x < \frac{3}{2}$   
iii)  $-2 < x < 7$

#### Exercise : 4.3

- 1) i) maximum at  $x = 1$ , max value = -3 & minimum at  $x = 6$ , min value = -128  
ii) minimum at  $x = \frac{1}{e}$ , min value =  $-\frac{1}{e}$   
ii) minimum at  $x = 2$ , min value = 12

- 2) first part = 10, second part = 10  
 3) Length = breadth = 9 cm  
 4) 30

### Exercise : 4.4

- 1) Decreasing function    2)  $D < 20$   
 3)  $x > 100$   
 4) i)  $x < 120$                   ii)  $x < 118$   
 5) i)  $x < 27$                     iii)  $x < 30$   
 6) i)  $x < 10$ ,  $C_A$  increasing.  
     ii)  $x > 10$ ,  $C_A$  decreasing  
 7) i)  $R_A = 36$                   ii)  $P = 42$   
     iii)  $\eta = 3$   
 8) 3.6                                  9)  $P = \frac{3}{2}$   
 10) i)  $\eta = 6.5$  elastic    ii)  $\frac{7}{20}$  inelastic  
 11) i)  $\eta = 2$  elastic            ii)  $\frac{18}{41}$  inelastic  
 12) i)  $R$  increasing,  $x < 60$   
     ii) Profit increasing,  $x < 59$   
     ii)  $\eta = 2$   
 13) i)  $MPC = 0.675$ ,  $MPS = 0.325$   
     ii)  $APC = 0.375$ ,  $APS = 0.625$

### MISCELLANEOUS EXERCISE - 4

- I.  
 1) a    2) a    3) c    4) b    5) a    6) c
- II.  
 1) gradient                      2)  $6(x - 1)$   
 3)  $14x^{-3}$                       4)  $x = 27, y = 27$   
 5)  $\frac{-1}{e}$

- III.  
 1) True                      2) False    3) True

### IV.

- 1) i)  $\left(y - \frac{c}{t}\right) = \frac{1}{t^2} (x - ct)$  ;  
      $\left(y - \frac{c}{t}\right) = -t^2 (x - ct)$   
 ii) for  $(-3, -3)$   $2x + y + 9 = 0$  ;  $x - 2y - 3 = 0$  and for  $(-1, -3)$   $2x - y - 1 = 0$  ;  
      $x + 2y + 7 = 0$   
 iii)  $10x + 2y - 8 = 0$ ;  $2x - 10y + 14 = 0$   
 iv)  $16x - y + 19 = 0$ ;  $x + 16y + 210 = 0$   
 v)  $x - 2y - 2 = 0$   
 vi) max at 2 and min at 4

## 5. Integration

### Exercise : 5.1

- i)  $\frac{2}{15} \left( (5x-4)^{3/2} + (5x-2)^{3/2} \right) + c$   
 ii)  $x + \frac{x^2}{2} + \frac{x^3}{6}$   
 iii)  $x^3 - 4\sqrt{x}$   
 iv)  $\left(\frac{9x^5}{5}\right) - 10x^3 + 25x + c$   
 v)  $\log \left| \frac{x-1}{x} \right| + c$   
 vi)  $f(x) = x^2 + 5$  and  $f(0) = -1$   $f(x) = \frac{x^3}{3} + 5x + c$   
     If  $x = 0$ , then  $f(0) = c \Leftrightarrow c = -1$  Hence  
      $f(x) = \frac{x^3}{3} + 5x - 1$  .  
 vii)  $f(x) = x^4 - x^3 + x^2 + 2x + 1$   
 viii)  $f(x) = \frac{x^3}{6} - \frac{x^2}{2} + x + 2$

**Exercise : 5.2**

i)  $\frac{1}{3}(1+x^2)^{\frac{3}{2}} + c$

ii)  $\frac{1}{2}\sqrt{1+x^4} + c$

iii)  $\frac{(e^x + e^{-x})^3}{3} + c$

iv)  $\log|xe^x + 1| + c$

v)  $\frac{(x+2)^{10}}{10} - \frac{(x+2)^8}{8} + c$

vi)  $\log|\log x| + c$

vii)  $\frac{1}{4}(x^1+1)^2 - (x^2+1) + \frac{1}{2}\log(x^2+1) + c$

viii)  $2\sqrt{x^2+6x+3} + c$

ix)  $2\log|\sqrt{x}+1| + c$

x)  $\frac{1}{6}\log\left|\frac{x^6}{x^6+1}\right| + c$

ii)  $\frac{1}{6}\log\left|\frac{x-1}{x+5}\right| + c$

iii)  $\frac{1}{8\sqrt{2}}\log\left|\frac{2x-5-2\sqrt{2}}{2x-5+2\sqrt{2}}\right| + c$

iv)  $\frac{1}{4\sqrt{13}}\log\left|\frac{4x^2-1-\sqrt{13}}{4x^2-1+\sqrt{13}}\right| + c$

v)  $\frac{1}{16}\log\left|\frac{4x^4-5}{4x^4+5}\right| + c$

vi)  $\frac{1}{2ab}\log\left|\frac{a+bx}{a-bx}\right| + c$

vii)  $\frac{1}{8}\log\left|\frac{1+x}{7-x}\right| + c$

viii)  $\frac{1}{\sqrt{3}}\log\left|\sqrt{3x} + \sqrt{3x^2+8}\right| + c$

ix)  $\log\left|(x+2) + \sqrt{x^2+4x+29}\right| + c_1$

x)  $\frac{1}{\sqrt{3}}\log\left|\sqrt{3x} + \sqrt{3x^2-5}\right| + c$

xi)  $\log\left|(x-4) + \sqrt{(x-4)^2-6^2}\right| + c$

xi)  $\log\left|(x-4) + \sqrt{x^2-8x-20}\right| + c$

**Exercise : 5.3**

i)  $-t + \frac{7}{8}\log|4e^{2t}-5| + c$

ii)  $5x + \log|3e^x-4| + c$

iii)  $\frac{-1}{2}x + 2\log|2e^x-8| + c$

iv)  $5x - 8\log|2e^x+1| + c$

**Exercise : 5.4**

i)  $\frac{1}{4}\log\left|\frac{2x-1}{2x+1}\right| + c$

**Exercise : 5.5**

i)  $\frac{x^2}{2}\log x - \frac{x^2}{4} + c$

ii)  $\frac{e^{4x}}{4}\left[x^2 - \frac{x}{2} + \frac{1}{8}\right] + c$

iii)  $\frac{1}{3}x^2e^{3x} - \frac{2}{9}xe^{3x} + \frac{2}{27}e^{3x} + c$

iv)  $\frac{1}{2}\{(x^2-1)e^{x^2} + c\}$

v)  $e^x \frac{1}{x} + c$

vi)  $e^x \frac{1}{x+1} + c$

vii)  $e^x \frac{1}{(x+1)^2} + c$

viii)  $e^x (\log x)^2 + c$

ix)  $\frac{x}{\log x} + c$

x)  $\frac{x}{1+\log x} + c$

II. 1)  $x^5 - \frac{5}{3}x^3 + 5x + c$

2)  $x + 4 \log(x-1) + c$

3)  $f(x) = \log x + \frac{x^2}{2} + c$

4)  $1 + \log x = t$

5)  $p = \frac{1}{3}$

III. 1) True    2) False    3) True

4) True    5) False

IV. 1) i)  $\frac{5x^2}{4} + \frac{3x}{4} + \frac{21}{8} \log|2x-3| + c$

ii)  $\frac{9}{65}(5x+1)^{13/9} + c$

iii)  $\frac{\log|2x+3|}{2} + c$

iv)  $\frac{2}{3}(x+4)^{3/2} - 10\sqrt{x+4} + c$

v)  $\frac{2x^{3/2}}{3} + \frac{4}{3}$

vi)  $-\frac{x^2}{2} + c$

2) i)  $-\log|e^{-x} + 1| + c$

ii)  $\frac{1}{2(ae^x - be^{-x})} + c$

iii)  $\frac{\log|2+3\log x|}{3} + c$

iv)  $2 \log|1+\sqrt{x}| + c$

v)  $-3x + \frac{7}{2} \log|4e^x + 1| + c$

3) i)  $\frac{1}{2} \log \left| x + \sqrt{x^2 - \frac{5}{4}} \right| + c$

ii)  $\frac{1}{4} \log \left| \frac{3+x}{1-x} \right| + c$

**Exercise : 5.6**

i)  $\frac{1}{3} \log|x+1| + \frac{5}{3} \log|x-2| + c$

ii)  $\frac{1}{4} \log|x| - \log|x-1| + \frac{3}{4} \log|x-4| + c$

iii)  $x - \log|x+3| + \log|x-2| + c$

iv)  $\frac{2}{9} \log \left| \frac{x-1}{x+2} \right| - \frac{1}{3(x-1)} + c$

v)  $\frac{11}{4} \log \left| \frac{x+1}{x+3} \right| + \frac{5}{2(x+1)} + c$

vi)  $\frac{1}{5} \log \left| \frac{x^5}{x^5+1} \right| + c$

vii)  $\frac{1}{n} \log \left| \frac{x^n}{x^n+1} \right| + c$

viii)  $6 \log|x| - \log|x+1| - \frac{9}{x+1} + c$

**MISCELLANEOUS EXERCISE - 5**

I. 1) b    2) a    3) b    4) c    5) a

6) c    7) b    8) a    9) b    10) a

$$\text{iii) } \frac{1}{30} \log \left| \frac{3x-5}{3x+5} \right|$$

$$\text{iv) } \log \left| e^x + 2 + \sqrt{e^{2x} + 4e^x + 13} \right| + c$$

$$\text{v) } \frac{1}{2\sqrt{5}} \log \left| \frac{\log x + 2 - \sqrt{5}}{\log x + 2 + \sqrt{5}} \right| + c$$

$$\text{vi) } \frac{1}{8\sqrt{5}} \log \left| \frac{\sqrt{5} + 4x}{\sqrt{5} - 4x} \right| + c$$

$$\text{vii) } \frac{1}{10} \log \left| \frac{5 + \log x}{5 - \log x} \right|$$

$$\text{viii) } \frac{1}{4} \log \left| \frac{e^x - 1}{e^x + 1} \right| + c$$

$$4) \text{ i) } x(\log x)^2 - 2x \log x + 2x + c$$

$$\text{ii) } \frac{e^x}{2+x} + c$$

$$\text{iii) } \frac{(2x-1)}{4} e^{2x}$$

$$\text{iv) } x \left[ \log(x^2 + x) \right] - 2x + \log|x+1| + c$$

$$\text{v) } 2(\sqrt{x}-1)e^{\sqrt{x}} + c$$

$$\text{vi) } \frac{x+1}{2} \sqrt{x^2+2x+5} + 2 \log|(x+1) + \sqrt{x^2+2x+5}| + c$$

$$\text{vii) } \frac{(x-4)}{2} \sqrt{x^2-8x+7} - \frac{9}{2} \log|(x-4) + \sqrt{x^2-8x+7}| + c$$

$$5) \text{ i) } \frac{2}{3} \log|x-1| + \frac{5 \log|2x+1|}{3 \cdot 2} + c$$

$$\text{ii) } \frac{x^2}{2} - x + \log \left( \frac{x+2}{2x+5} \right) + c$$

$$\text{iii) } \frac{2}{7} \log(3 + \log x) + \frac{1}{21} \log(2 + 3 \log x) + c$$

## 6. Definite Integrals

### Exercise : 6.1

- 1) 2                      2)  $\log\left(\frac{8}{3}\right)$                       3)  $\frac{1}{2} \log\left(\frac{8}{3}\right)$   
 4)  $\frac{32}{5}$                       5)  $\log\left(\frac{3456}{3125}\right)$                       6)  $\frac{1}{4} \log\left(\frac{9}{7}\right)$   
 7)  $a = -2$  or 1                      8)  $a = 2$                       9)  $\frac{4}{3}(\sqrt{2}-1)$   
 10)  $\frac{1}{6} \log\left(\frac{35}{8}\right)$   
 11)  $\log 27 - 4$  or  $3 \log 3 - 4$

### Exercise : 6.2

- 1) 0                      2)  $\frac{16}{315} a^{9/2}$                       3) 1  
 4)  $\frac{3}{2}$                       5)  $\frac{1}{2}$                       6)  $\frac{5}{2}$   
 7) 0                      8)  $\frac{1}{4^2}$

## MISCELLANEOUS EXERCISE - 6

I.

- 1) a                      2) b                      3) c                      4) c  
 5) a                      6) d                      7) d                      8) c  
 9) c                      10) b

II.

- 1) i)  $e^2 - 1$                       2)  $\frac{211}{5}$                       3)  $\frac{1}{2} \log\left(\frac{7}{2}\right)$   
 4) 2                      5) 2                      6)  $\frac{1}{2} \log\left(\frac{8}{3}\right)$   
 7)  $\log\left(\frac{8}{3}\right)$                       8) 0

III.

- 1) True      2) True      3) False  
 4) False    5) True      6) True  
 7) False    8) True

IV.

- 1)  $3\log|x+3| - 2\log|x+2| + c$   
 2)  $\frac{\log 6}{2}$                       3)  $9\log 3 - \frac{26}{9}$   
 4)  $\frac{1}{2}$                             5)  $\frac{e^4 - e^2}{4 - 2}$   
 6) 2                              7)  $\log \frac{8}{3}$   
 8)  $\frac{1}{2} \log \frac{8}{3}$                       9)  $\frac{32}{5}$   
 10)  $\frac{1}{9}(28 - 3\sqrt{3} - 7\sqrt{7})$     11)  $\log \sqrt{2}$   
 12)  $\frac{7}{3}$                             13)  $-\log 4$   
 14)  $\frac{4}{3}(\sqrt{2} - 1)$               15)  $\log \left( \frac{5 + 3\sqrt{3}}{1 + \sqrt{3}} \right)$   
 16)  $\frac{1}{2} \log \left( \frac{17}{5} \right)$                       17)  $-\frac{1}{2} \log 3$   
 18)  $5 + \frac{1}{2}(5\log 3 + 85\log 2 - 45\log 2)$   
 19)  $\frac{\log 2}{1 + \log 2}$                       20)  $6 - 4\log 2$

## 7. Applications of Definite Integral

### Exercise : 7.1

- 1) i)  $\frac{3124}{5}$  sq. units    ii)  $\frac{56}{3}$  sq. units  
 iii)  $4\pi$  sq. units    iv)  $96$  sq. units

v) 5 sq. units      vi) 12 sq. units

vii)  $\frac{10}{3}$  sq. units

2)  $8\sqrt{3}$  sq. units

3)  $25\pi$  sq. units

4)  $10\pi$  sq. units

## MISCELLANEOUS EXERCISE - 7

I. 1) a      2) c      3) c      4) b      5) c

II. 1)  $\frac{3124}{5}$  sq. units

2)  $49\pi$  sq. units

3)  $\frac{56}{3}$  sq. units

4)  $\frac{70}{3}$  sq. units

5)  $\frac{28}{3}$  sq. units

III. 1) True                      2) False

3) True                      4) False

5) True

IV. 1)  $c^2 \log 2$  sq. units

2)  $\frac{49}{3}$  sq. units

3)  $\frac{40\sqrt{10}}{3}$  sq. units

4)  $12\pi$  sq. units

5) 21 sq. units

6)  $\frac{70}{3}$  sq. units

7)  $A = 2 \int_0^5 y \, dx = 2 \int_0^5 5\sqrt{x} \, dx$

$= \frac{100\sqrt{5}}{3}$  sq. units

## 8. Differential Equations and Applications

### Exercise : 8.1

1.

	order	Degree
i	2	1
ii	2	2
iii	4	1
iv	3	2
v	1	5
vi	2	1
vii	3	1

### Exercise : 8.2

- 1) i)  $\frac{dy^2}{dx^2} = 9y$
- ii)  $x^2 \frac{dy^2}{dx^2} + 2x \frac{dy}{dx} = 0$
- iii)  $\frac{dy^2}{dx^2} - 2 \frac{dy}{dx} + y = 0$
- iv)  $\frac{d^2y}{dx^2} - 5 \frac{dy}{dx} + 6y = 0$
- v)  $\frac{dy}{dx} = \frac{3}{2} \sqrt[3]{y}$
- 2)  $2xy \frac{dy}{dx} = y^2 - x^2$
- 3)  $\frac{d^2y}{dx^2} = 0$
- 4)  $2x^3 - y^3 + 3xy^2 \frac{dy}{dx} = 0$
- 5)  $x + 4y \frac{dy}{dx} = 0$

### Exercise : 8.3

1. i)  $\log y = \frac{x^3}{3} + x + c$
- ii)  $\theta - \theta_0 = e^{-kt+c}$
- iii)  $\log x - \log y = \frac{1}{x} + \frac{1}{y} + c$
- iv)  $2y^2 \log|1+x| = -1 + 2y^2c$
2. i)  $|1+x^2||1-y^2| = 5$
- ii)  $3x - 2e^y - 1 = 0$
- iii)  $ex \log x = y$
- iv)  $\log \left| \frac{4x+y+5}{6} \right| = x+c$

### Exercise : 8.4

- 1)  $x^2 + 2y^2 = c$
- 2)  $\log x + \frac{1}{4} \log \left| \frac{2y^2 + xy}{x^2} \right| + \frac{3}{4} \log \left| \frac{2y}{x+2y} \right| = c$
- 3)  $\frac{x^3}{3y^3} = \log yc$
- 4)  $\log \left| \frac{x+y}{x-y} \right| - \frac{1}{2} \log |x^2 - y^2| + 2 \log x = \log c$
- 5)  $x^2 + y^2 = xc$
- 6)  $x^2 + y^2 = cx^4$
- 7)  $\frac{x+y}{x-y} = cx^2$

### Exercise : 8.5

- 1)  $ye^x = x + c$
- 2)  $ye^x = 3e^x + c$



$$3) \quad yx^2 = \log x \cdot \frac{x^4}{4} - \frac{x^4}{16} + c$$

$$4) \quad x + y + 1 = c \cdot e^y$$

$$5) \quad 3xy = y^3 + c$$

$$6) \quad ye^{x^2} = \frac{1}{2}e^{x^2} + c$$

$$7) \quad y(x+a) = ax + c$$

$$8) \quad ye^{2x} = 4e^{2x} + c$$

### Exercise : 8.6

$$1) \quad 8$$

$$2) \quad 73482$$

$$3) \quad 45248$$

$$4) \quad 30000 \left(\frac{4}{3}\right)^{\frac{t}{40}}$$

$$5) \quad \text{Rs. } 628571$$

### MISCELLANEOUS EXERCISE - 8

I. 1) a 2) c 3) b 4) a 5) d 6) c 7) d 8) b  
9) c 10) a

II.

1) Order of the differential equation

2) Degree of the differential equation

3) Particular solution

4) Positive

$$5) \quad e^{-x} \quad 6) \quad \frac{d^2y}{dx^2} = 0$$

III.

1) True 2) True 3) True

4) False 5) False 6) True

IV.

1) i) Order : 3 , Degree : 3

ii) Order : 1 , Degree : 3

$$2) \quad x \frac{d^2y}{dx^2} + \frac{dy}{dx} = 0$$

$$3) \quad \text{i) } \log|1+y| = x + \frac{x^2}{2} + c$$

$$\text{ii) } y = x(\log x - 1) + c$$

$$\text{iii) } \log r = a \log |1 + \theta| + c$$

$$\text{iv) } \frac{x^2 d^2y}{dx^2} - 2x^2 \frac{dy}{dx} - 2x \frac{dy}{dx} + x^2y + 2y + 2xy = 0$$

$$4) \quad \log|x+y| = y - x + \frac{1}{3}$$

$$5) \quad \log|x+y+1| = cx$$

$$6) \quad 2xlogy = (logy)^2 + c$$

$$7) \quad a^3 + x + y = ce^{\frac{y}{a^2}}$$

$$8) \quad 5x^2y = x^5 + c$$

9) 50 years

10) Rs. 10,000

$$11) \quad xy^2 = c^2(x+2y)$$

$$12) \quad \log y - \frac{x^3}{3y^3} = c$$

$$13) \quad x^2 + y^2 = c^2x^4$$

$$14) \quad x = y(c+y^2)$$

$$15) \quad y = c \cdot x - (1 + \log x)$$

$$16) \quad y = x \log x - x + c$$

$$17) \quad xlogy = \frac{1}{2}(\log y)^2 + c$$





# *Practical Notebook for Standard XII*

## *Practical Notebook Cum Journal - Mathematics*

English  
Medium

Price  
₹ 57.00

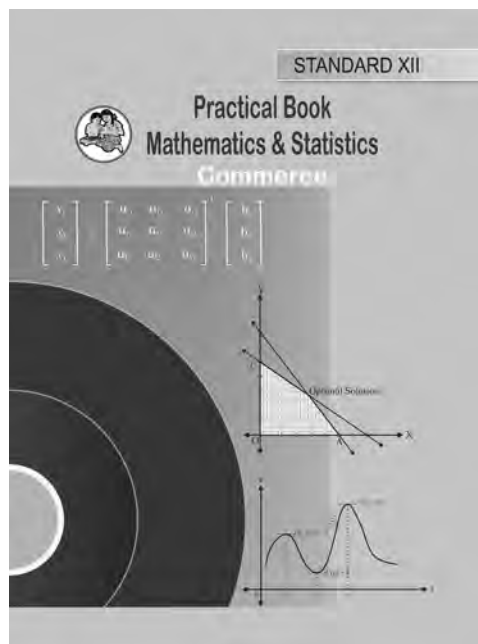

- Based on Government approved syllabus and textbook
- Inclusion of practicals based on all chapters as per Evaluation scheme.
- With full of various activities, pictures, figures/ diagrams, etc.
- Inclusion of objective/multiple choice questions
- Inclusion of useful questions for oral examination
- More questions for practice and separate space for writing answers

***Practical notebooks are available for sale in the regional depots of the Textbook Bureau.***

(1) Maharashtra State Textbook Stores and Distribution Centre, Senapati Bapat Marg, Pune 411004 ☎ 25659465  
(2) Maharashtra State Textbook Stores and Distribution Centre, P-41, Industrial Estate, Mumbai - Bengaluru Highway, Opposite Sakal Office, Kolhapur 416122 ☎ 2468576 (3) Maharashtra State Textbook Stores and Distribution Centre, 10, Udyognagar, S. V. Road, Goregaon (West), Mumbai 400062 ☎ 28771842  
(4) Maharashtra State Textbook Stores and Distribution Centre, CIDCO, Plot no. 14, W-Sector 12, Wavanja Road, New Panvel, Dist. Rajgad, Panvel 410206 ☎ 274626465 (5) Maharashtra State Textbook Stores and Distribution Centre, Near Lekhanagar, Plot no. 24, 'MAGH' Sector, CIDCO, New Mumbai-Agra Road, Nashik 422009 ☎ 2391511 (6) Maharashtra State Textbook Stores and Distribution Centre, M.I.D.C. Shed no. 2 and 3, Near Railway Station, Aurangabad 431001 ☎ 2332171 (7) Maharashtra State Textbook Stores and Distribution Centre, Opposite Rabindranath Tagore Science College, Maharaj Baug Road, Nagpur 440001 ☎ 2547716/2523078 (8) Maharashtra State Textbook Stores and Distribution Centre, Plot no. F-91, M.I.D.C., Latur 413531 ☎ 220930 (9) Maharashtra State Textbook Stores and Distribution Centre, Shakuntal Colony, Behind V.M.V. College, Amravati 444604 ☎ 2530965



ebalbharati

E-learning material (Audio-Visual) for Standards One to Twelve is available through Textbook Bureau, Balbharati...

- Register your demand by scanning the Q.R. Code given alongside.
  - Register your demand for E-learning material by using Google play store and downloading ebalbharati app.
- www.ebalbharati.in, www.balbharati.in



$$\begin{bmatrix} a_{11} & a_{12} & a_{13} \\ a_{21} & a_{22} & a_{23} \\ a_{31} & a_{32} & a_{33} \end{bmatrix} \begin{bmatrix} x_1 \\ x_2 \\ x_3 \end{bmatrix} = \begin{bmatrix} b_1 \\ b_2 \\ b_3 \end{bmatrix}$$

$$x^2 \frac{d^2y}{dx^2} + x \frac{dy}{dx} + y = 0$$

$$xdy + ydx = 0$$

$$\int e^x dx = e^x + C$$

$$\int x^n dx = \frac{x^{n+1}}{n+1} + c, n \neq -1$$



**Maharashtra State Bureau of Textbook  
Production and Curriculum Research,  
Pune - 411 004.**

गणित आणि संख्याशास्त्र (वाणिज्य) भाग-१, (इंग्रजी माध्यम) इ. १२ वी ₹ 114.00