

**PHYSICS**

**SECTION - A**

**Multiple Choice Questions:** This section contains 20 multiple choice questions. Each question has 4 choices (1), (2), (3) and (4), out of which **ONLY ONE** is correct.

**Choose the correct answer:**

1. The electric potential at the centre of two concentric half rings of radii  $R_1$  and  $R_2$ , having same linear charge density  $\lambda$  is:

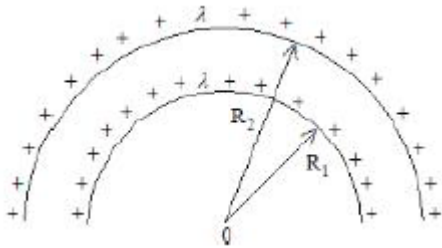

- (1)  $\frac{\lambda}{4\epsilon_0}$                       (2)  $\frac{\lambda}{2\epsilon_0}$   
 (3)  $\frac{2\lambda}{\epsilon_0}$                         (4)  $\frac{\lambda}{\epsilon_0}$

**Answer (2)**

**Sol.**  $V_1 = \frac{1}{4\pi\epsilon_0} \times \frac{\lambda(\pi R_1)}{R_1}$

$V_2 = \frac{1}{4\pi\epsilon_0} \times \frac{\lambda(\pi R_2)}{R_2}$

$V_{net} = V_1 + V_2$   
 $= 2 \times \frac{1}{4\pi\epsilon_0} \pi\lambda$   
 $= \frac{\lambda}{2\epsilon_0}$

2. A body of mass 200 g is tied to a spring of spring constant 12.5 N/m, while the other end of spring is fixed at point O. If the body moves about O in a circular path on a smooth horizontal surface with constant angular speed 5 rad/s. Then the ratio of extension in the spring to its natural length will be:

- (1) 1 : 1  
 (2) 1 : 2  
 (3) 2 : 3  
 (4) 2 : 5

**Answer (3)**

**Sol.**

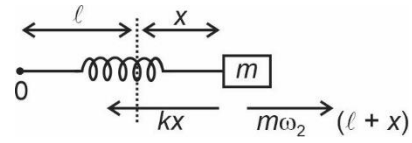

$\therefore kx = m\omega^2 (l + x)$

$12.5(x) = \frac{1}{5}(5)^2(l + x)$

$\Rightarrow \frac{5}{2}x = l + x$

$\Rightarrow \frac{3}{2}x = l$

$\Rightarrow \frac{x}{l} = \frac{2}{3}$

3. The electric field and magnetic field components of an electromagnetic wave going through vacuum is described by

$E_x = E_0 \sin(kz - \omega t)$

$B_y = B_0 \sin(kz - \omega t)$

Then the correct relation between  $E_0$  and  $B_0$  is given by

- (1)  $\omega E_0 = kB_0$   
 (2)  $E_0 = kB_0$   
 (3)  $kE_0 = \omega B_0$   
 (4)  $E_0 B_0 = \omega k$

**Answer (3)**

**Sol.**  $E_x = E_0 \sin(kz - \omega t)$

$B_y = B_0 \sin(kz - \omega t)$

$\therefore \text{Velocity} = \frac{E_0}{B_0}$

$\frac{\omega}{k} = \frac{E_0}{B_0}$

$\omega B_0 = kE_0$

4. In an Isothermal change, the change in pressure and volume of a gas can be represented for three different temperature;  $T_3 > T_2 > T_1$  as:

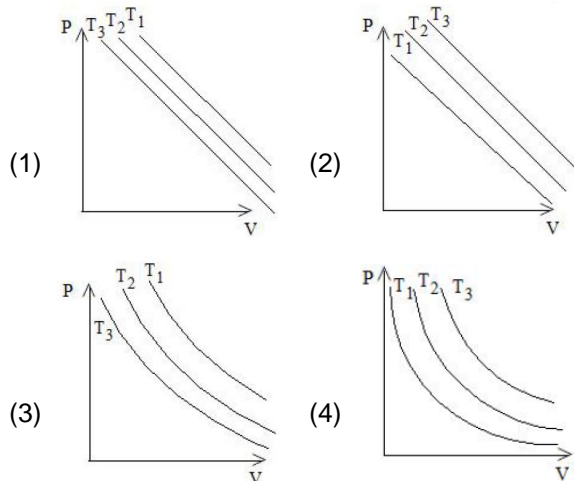

**Answer (4)**

**Sol.** Correct graph is

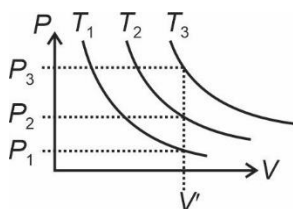

Because at constant volume  $V$

$$P_3 > P_2 > P_1$$

$$\therefore T_3 > T_2 > T_1$$

5. Given below are two statements:

**Statement I:** Acceleration due to earth's gravity decreases as you go 'up' or 'down' from earth's surface.

**Statement II:** Acceleration due to earth's gravity is same at a height 'h' and depth 'd' from earth's surface, if  $h = d$ .

In the light of above statements, choose the **most appropriate** answer from the options given below.

- (1) Both Statement I and II are correct
- (2) Statement I is correct but statement II is incorrect
- (3) Both Statement I and Statement II are incorrect
- (4) Statement I is incorrect but statement II is correct

**Answer (2)**

**Sol.** Statement I is correct as

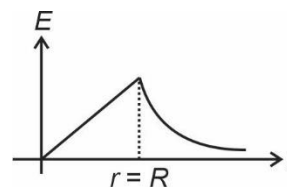

Statement II is incorrect as  $E_{\text{above}}$  and  $E_{\text{below}}$  the surface have different relation with height and depth respectively.

6. Match List I with List II

List I		List II	
A.	AM Broadcast	I.	88-108 MHz
B.	FM Broadcast	II.	540-1600 kHz
C.	Television	III.	3.7-4.2 GHz
D.	Satellite Communication	IV.	54 MHz-890 MHz

Choose the correct answer from the options given below:

- (1) A-I, B-III, C-II, D-IV
- (2) A-IV, B-III, C-I, D-II
- (3) A-II, B-III, C-I, D-IV
- (4) A-II, B-I, C-IV, D-III

**Answer (4)**

**Sol.** AM band is in kHz A-II  
 FM is in 88-108 MHz B-I  
 TV frequency in 54-890 MHz C-IV  
 Satellite Communication is in GHz D-III

7. If two vectors  $\vec{P} = \hat{i} + 2m\hat{j} + m\hat{k}$  and  $\vec{Q} = 4\hat{i} + 2\hat{j} + m\hat{k}$  are perpendicular to each other. Then, the value of  $m$  will be :

- (1) -1
- (2) 2
- (3) 3
- (4) 1

**Answer (2)**

**Sol.**  $\vec{P}$  &  $\vec{Q}$  are perpendicular

$$\begin{aligned} \therefore \vec{P} \cdot \vec{Q} &= 0 \\ \Rightarrow 4 - 4m + m^2 &= 0 \\ &= m = 2 \end{aligned}$$

8. A photon is emitted in transition from  $n = 4$  to  $n = 1$  level in hydrogen atom. The corresponding wavelength for this transition is

- (given,  $h = 4 \times 10^{-15}$  eVs) :
- (1) 941 nm
  - (2) 99.3 nm
  - (3) 94.1 nm
  - (4) 974 nm

**Answer (3)**

**Sol.**  $\frac{hc}{\lambda} = +13.6\text{eV} \left[ \frac{1}{1} - \frac{1}{4^2} \right]$   
 $\Rightarrow \frac{4 \times 10^{-15} \times 3 \times 10^{-8}}{\lambda} = 13.6 \left[ \frac{15}{16} \right]$

$\lambda = 94.1 \text{ nm}$

9. The velocity-time graph of a body moving in a straight line is shown in figure.

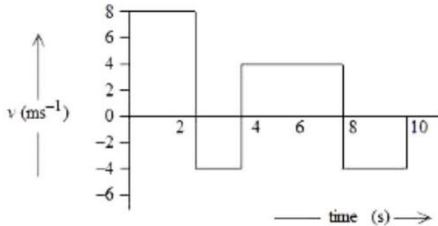

The ratio of displacement to distance travelled by the body in time 0 to 10 s is :

- (1) 1 : 4                                      (2) 1 : 2  
 (3) 1 : 3                                      (4) 1 : 1

**Answer (3)**

**Sol.** From  $v-t$  graph

Displacement = Area under curve considering sign also.

Distance = Area under curve considering only magnitude

Distance = 48

Displacement = 16 m

Displacement : distance = 1 : 3

10. Let  $\gamma_1$  be the ratio of molar specific heat at constant pressure and molar specific heat at constant volume of a monoatomic gas and  $\gamma_2$  be the similar ratio of diatomic gas. Considering the diatomic gas

molecule as a rigid rotator, the ratio,  $\frac{\gamma_1}{\gamma_2}$  is :

- (1)  $\frac{27}{35}$                                       (2)  $\frac{35}{27}$   
 (3)  $\frac{25}{21}$                                       (4)  $\frac{21}{25}$

**Answer (3)**

**Sol.**  $\gamma_1 = \frac{C_P}{C_V} \Big|_{\text{mono-atomic gas}} = \frac{5}{3}$

$\gamma_2 = \frac{C_P}{C_V} \Big|_{\text{di-atomic gas}} = \frac{7}{5}$

$\frac{\gamma_1}{\gamma_2} = \frac{25}{21}$

11. A long solenoid is formed by winding 70 turns  $\text{cm}^{-1}$ . If 2.0 A current flows, then the magnetic field produced inside the solenoid is \_\_\_\_\_  
 ( $\mu_0 = 4\pi \times 10^{-7} \text{ TmA}^{-1}$ )

- (1)  $88 \times 10^{-4} \text{ T}$                               (2)  $352 \times 10^{-4} \text{ T}$   
 (3)  $1232 \times 10^{-4} \text{ T}$                               (4)  $176 \times 10^{-4} \text{ T}$

**Answer (4)**

**Sol.** Number of turns per meter = 7000 turns per m

$i = 2 \text{ A}$

$B = \mu_0 ni = 4\pi \times 10^{-7} \times 7000 \times 2$   
 $= 56\pi \times 10^{-4} \text{ T}$   
 $= 56 \times \frac{22}{7} \times 10^{-4} \text{ T}$   
 $= 176 \times 10^{-4} \text{ T}$

12. Given below are two statements: one is labelled as **Assertion A** and the other is labelled as **Reason R**

**Assertion A** : Steel is used in the construction of buildings and bridges.

**Reason R** : Steel is more elastic and its elastic limit is high.

In the light of above statements, choose the most appropriate answer from the options given below.

- (1) Both **A** and **R** are correct and **R** is the correct explanation of **A**  
 (2) **A** is correct but **R** is not correct  
 (3) Both **A** and **R** are correct but **R** is not the correct explanation of **A**  
 (4) **A** is not correct but **R** is correct

**Answer (1)**

**Sol.** Steel is more elastic and has high elastic limit.

13. If the distance of the earth from Sun is  $1.5 \times 10^6 \text{ km}$ . Then the distance of an imaginary planet from Sun, if its period of revolution is 2.83 years is:

- (1)  $6 \times 10^6 \text{ km}$                               (2)  $3 \times 10^7 \text{ km}$   
 (3)  $3 \times 10^6 \text{ km}$                               (4)  $6 \times 10^7 \text{ km}$

**Answer (3)**

**Sol.**  $T \propto r^{\frac{3}{2}}$

$\frac{T_e}{T_p} = \left( \frac{r_e}{r_p} \right)^{\frac{3}{2}}$

$\Rightarrow \left( \frac{1 \text{ year}}{2.83 \text{ year}} \right)^{\frac{2}{3}} = \left( \frac{1.5 \times 10^6 \text{ km}}{r_p} \right)$

$\Rightarrow \frac{1}{2} = \frac{1.5 \times 10^6 \text{ km}}{r_p}$

$r_p = 3 \times 10^6 \text{ km}$

14. The frequency ( $\nu$ ) of an oscillating liquid drop may depend upon radius ( $r$ ) of the drop, density ( $\rho$ ) of liquid and the surface tension ( $s$ ) of the liquid as :  $\nu = r^a \rho^b s^c$ . The values of  $a$ ,  $b$  and  $c$  respectively are

- (1)  $\left(-\frac{3}{2}, \frac{1}{2}, \frac{1}{2}\right)$       (2)  $\left(\frac{3}{2}, -\frac{1}{2}, \frac{1}{2}\right)$   
 (3)  $\left(-\frac{3}{2}, -\frac{1}{2}, \frac{1}{2}\right)$       (4)  $\left(\frac{3}{2}, \frac{1}{2}, -\frac{1}{2}\right)$

**Answer (3)**

**Sol.**  $[\nu] = [T^{-1}]$

$$[r] = L \qquad [s] = \left[ \frac{MLT^{-2}}{L} \right]$$

$$[\rho] = \left[ \frac{M}{L^3} \right] = [ML^{-3}]$$

$$\Rightarrow \nu = r^a \rho^b s^c$$

$$\Rightarrow T^{-1} = L^a M^b L^{-3b} M^c T^{-2c}$$

$$\Rightarrow T^{-1} = M^{(b+c)} L^{(a-3b)} T^{-2c}$$

$$-2c = -1 \Rightarrow c = \frac{1}{2}$$

$$b + c = 0$$

$$\Rightarrow b = -\frac{1}{2}$$

$$a - 3b = 0 \Rightarrow 3b = a \Rightarrow a = -\frac{3}{2}$$

$$(a, b, c) = \left(-\frac{3}{2}, -\frac{1}{2}, \frac{1}{2}\right)$$

15. A cell of emf 90 V is connected across series combination of two resistors each of 100  $\Omega$  resistance. A voltmeter of resistance 400  $\Omega$  is used to measure the potential difference across each resistor. The reading of the voltmeter will be :

- (1) 45 V      (2) 40 V  
 (3) 80 V      (4) 90 V

**Answer (2)**

**Sol.**

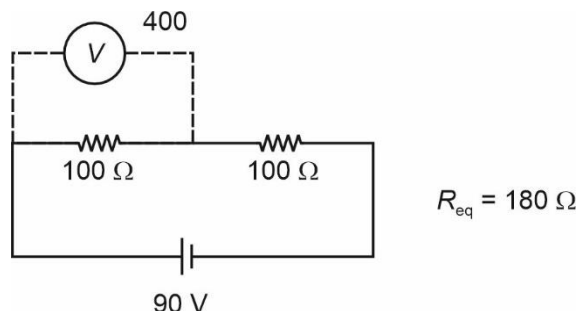

$$I = \frac{90}{180} = \left(\frac{1}{2} A\right)$$

Reading of voltmeter = 90 - 50 = 40 V

16. When a beam of white light is allowed to pass through convex lens parallel to principal axis, the different colours of light converge at different point on the principle axis after refraction. This is called

- (1) Spherical aberration  
 (2) Chromatic aberration  
 (3) Polarisation  
 (4) Scattering

**Answer (2)**

**Sol.** The phenomena is known as chromatic aberration.

17. An  $\alpha$ -particle, a proton and an electron have the same kinetic energy. Which one of the following is correct in case of their de-Broglie wavelength?

- (1)  $\lambda_\alpha > \lambda_p < \lambda_e$       (2)  $\lambda_\alpha = \lambda_p = \lambda_e$   
 (3)  $\lambda_\alpha > \lambda_p > \lambda_e$       (4)  $\lambda_\alpha < \lambda_p < \lambda_e$

**Answer (4)**

$$\text{Sol. } \lambda = \frac{h}{mv} = \frac{h}{\sqrt{2mk}}$$

$$\text{So, } \lambda \propto \frac{1}{\sqrt{m}}$$

$$\text{So, } \lambda_e > \lambda_p > \lambda_\alpha$$

18.

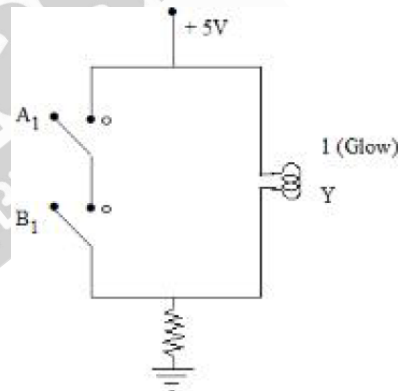

The logic gate equivalent to the given circuit diagram is

- (1) NAND      (2) NOR  
 (3) AND      (4) OR

**Answer (1)**

**Sol.** The truth table for the circuit will be given as below

A	B	Y
0	0	1
0	1	1
1	0	1
1	1	0

The above truth table is of NAND Gate.

19. Given below are two statements: One is labelled as **Assertion A** and the other is labelled as **Reason R**.

**Assertion A:** A pendulum clock when taken to Mount Everest becomes fast.

**Reason R:** The value of  $g$  (acceleration due to gravity) is less at Mount Everest than its value on the surface of earth.

In the light of the above statements, choose the **most appropriate** answer from the options given below.

- (1) A is not correct but R is correct
- (2) A is correct but R is not correct
- (3) Both A and R are correct but R is NOT the correct explanation of A
- (4) Both A and R are correct and R is the correct explanation of A

**Answer (1)**

**Sol.** When we go on the Mount Everest the value of

gravitational acceleration decreases  $g = \frac{g_0}{\left(1 + \frac{h}{R_e}\right)^2}$ .

Therefore, the time period of oscillation

$\left(T = 2\pi\sqrt{\frac{l}{g}}\right)$  increases and the pendulum clock

becomes slow thus the assertion is wrong but reason is correct.

20. A metallic rod of length ' $L$ ' is rotated with an angular speed of ' $\omega$ ' normal to a uniform magnetic field ' $B$ ' about an axis passing through one end of rod as shown in figure. The induced emf will be

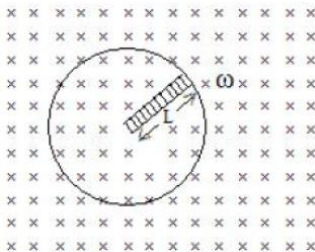

- (1)  $\frac{1}{2} B^2 L^2 \omega$
- (2)  $\frac{1}{2} B L^2 \omega$
- (3)  $\frac{1}{4} B L^2 \omega$
- (4)  $\frac{1}{4} B^2 L \omega$

**Answer (2)**

**Sol.** Velocity of centre of rod  $v = \frac{\omega L}{2}$

So,  $emf = B \cdot vL$

$= \frac{B\omega L^2}{2}$

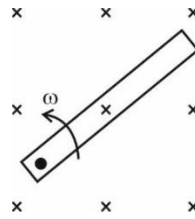

**SECTION - B**

**Numerical Value Type Questions:** This section contains 10 questions. In Section B, attempt any five questions out of 10. The answer to each question is a **NUMERICAL VALUE**. For each question, enter the correct numerical value (in decimal notation, truncated/rounded-off to the second decimal place; e.g. 06.25, 07.00, -00.33, -00.30, 30.27, -27.30) using the mouse and the on-screen virtual numeric keypad in the place designated to enter the answer.

21. A spherical ball of radius 1 mm and density 10.5 g/cc is dropped in glycerine of coefficient of viscosity 9.8 poise and density 1.5 g/cc. Viscous force on the ball when it attains constant velocity is  $3696 \times 10^{-x}$  N. The value of  $x$  is (Given,  $g = 9.8$  m/s<sup>2</sup> and  $\pi = \frac{22}{7}$ )

**Answer (7)**

**Sol.** At state of terminal speed, net force on the ball is zero

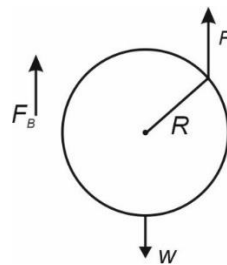

$\therefore F_v = W - F_B$

$= \left(\frac{4}{3}\pi R^3 \rho_b g\right) - \left(\frac{4}{3}\pi R^3 \rho_l g\right)$

$= \frac{4}{3}\pi R^3 (\rho_b - \rho_l) g$

$= \frac{4}{3} \times \frac{22}{7} \times (10^{-3})^3 [9 \times 10^3] \times 9.8$

$= 3696 \times 10^{-7}$

$\therefore \boxed{x=7}$

22. A parallel plate capacitor with air between the plate has a capacitance of 15 pF. The separation between the plate becomes twice and the space between them is filled with a medium of dielectric constant 3.5. Then the capacitance becomes  $\frac{x}{4}$  pF. The value of x is \_\_\_\_\_

**Answer (105)**

**Sol.** Initially

$$\frac{\epsilon_0 A}{d} = 15 \times 10^{-12} \text{F}$$

Finally

$$\frac{3.5 \epsilon_0 A}{2d} = \frac{x}{4} \times 10^{-12} \text{F}$$

$$\therefore \frac{3.5}{2} \times 15 = \frac{x}{4}$$

$$\Rightarrow x = \frac{3.5 \times 15 \times 4}{2} = 105$$

23. A mass  $m$  attached to free end of a spring executes SHM with a period of 1 s. If the mass is increased by 3 kg the period of oscillation increases by one second, the value of mass  $m$  is \_\_\_\_\_ kg

**Answer (1)**

$$\text{Sol. } \therefore 2\pi\sqrt{\frac{m}{k}} = 1 \quad \dots(1)$$

Finally

$$2\pi\sqrt{\frac{m+3}{k}} = 1+1 = 2 \quad \dots(2)$$

Equation  $\frac{(1)}{(2)}$  gives

$$\sqrt{\frac{m}{m+3}} = \frac{1}{2}$$

$$\therefore \boxed{m = 1 \text{ kg}}$$

24. A single turn current loop in the shape of a right angle triangle with sides 5 cm, 12 cm, 13 cm is carrying a current of 2 A. The loop is in a uniform magnetic field of magnitude 0.75 T whose direction is parallel to the current in the 13 cm side of the loop. The magnitude of the magnetic force on the 5 cm side will be  $\frac{x}{130}$  N. The value of x is \_\_\_\_\_

**Answer (9)**

**Sol.**

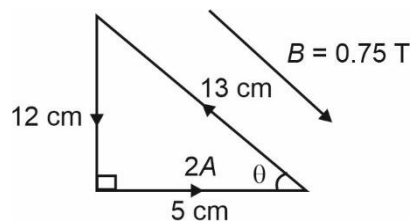

$$\text{Force on 5 cm side} = \ell B \sin\theta$$

$$= 2 \times \frac{5}{100} \times 0.75 \times \frac{12}{13}$$

$$= \frac{9}{130}$$

$$\therefore x = 9$$

25. A uniform solid cylinder with radius  $R$  and length  $L$  has moment of inertia  $I_1$ , about the axis of the cylinder. A concentric solid cylinder of radius  $R' = \frac{R}{2}$  and length  $L' = \frac{L}{2}$  is carved out of the original cylinder. If  $I_2$  is the moment of inertia of the carved out portion of the cylinder then  $\frac{I_1}{I_2} = \underline{\hspace{2cm}}$ .

(Both  $I_1$  and  $I_2$  are about the axis of the cylinder)

**Answer (32)**

$$\text{Sol. } I_1 = \frac{(\rho\pi R^2 L)R^2}{2} \quad (\rho : \text{density of cylinder})$$

$$I_2 = \frac{\left[ \rho\pi \left(\frac{R}{2}\right)^2 \frac{L}{2} \right] \left(\frac{R}{2}\right)^2}{2}$$

$$\therefore \frac{I_1}{I_2} = \frac{32}{1}$$

26. A convex lens of refractive index 1.5 and focal length 18 cm in air is immersed in water. The change in focal length of the lens will be \_\_\_\_\_ cm.

(Given refractive index of water =  $\frac{4}{3}$ ).

**Answer (54)**

**Sol.** From lens makers formula

$$\frac{1}{f} = \left( \frac{\mu_{\text{lens}}}{\mu_{\text{medium}}} - 1 \right) \left[ \frac{1}{R_1} - \frac{1}{R_2} \right]$$

when in air

$$\frac{1}{18} = \left( \frac{1.5}{1} - 1 \right) \left[ \frac{1}{R_1} - \frac{1}{R_2} \right] \quad \dots(1)$$

$$\mu_{\text{lens}} = 1.5, \mu_{\text{air}} = 1.$$



when in water

$$\frac{1}{f} = \left( \frac{1.5}{\frac{4}{3}} - 1 \right) \left[ \frac{1}{R_1} - \frac{1}{R_2} \right] \quad \dots(2)$$

from (1) & (2)

$$f = 72$$

$$\begin{aligned} \text{Change in focal length} &= 72 - 18 \\ &= 54 \end{aligned}$$

27. A body of mass 1 kg begins to move under the action of a time dependent force  $\vec{F} = (t\hat{i} + 3t^2\hat{j})\text{N}$ , where  $\hat{i}$  and  $\hat{j}$  are the unit vectors along x and y axis. The power developed by above force, at the time  $t = 2$  s, will be \_\_\_\_\_ W.

**Answer (100)**

**Sol.**  $\vec{F} = t\hat{i} + 3t^2\hat{j}$

$$\vec{a} = \frac{\vec{F}}{m} = t\hat{i} + 3t^2\hat{j} \quad (m = 1)$$

$$\vec{v} = \int_0^2 \vec{a} dt = 2\hat{i} + 8\hat{j} \quad (\vec{v} \text{ at } t = 2\text{s})$$

$$\begin{aligned} P &= \vec{F} \cdot \vec{v} = \vec{F}(t = 2\text{s}) \cdot \vec{v}(t = 2\text{s}) \\ &= (2\hat{i} + 12\hat{j}) \cdot (2\hat{i} + 8\hat{j}) \\ &= 4 + 96 \\ &= 100 \text{ W.} \end{aligned}$$

28. Three identical resistors with resistance  $R = 12 \Omega$  and two identical inductors with self-inductance  $L = 5 \text{ mH}$  are connected to an ideal battery with emf of 12 V as shown in figure. The current through the battery long after the switch has been closed will be \_\_\_\_\_ A.

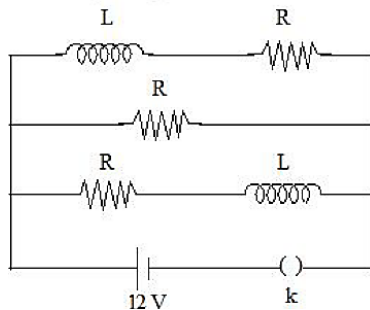

**Answer (03)**

**Sol.** After long time, inductors are shorted.

Effective circuit becomes

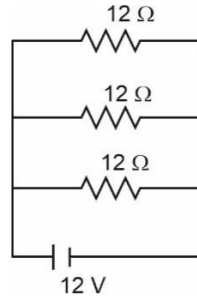

$$\text{Current through battery} = \frac{V}{R_{\text{eq}}} = \frac{12\text{V}}{4\Omega} = \boxed{3\text{A}}$$

where  $R_{\text{eq}} = 3$  resistors in parallel.

29. The energy released per fission of nucleus of  $^{240}\text{X}$  is 200 MeV. The energy released if all the atoms in 120 g of pure  $^{240}\text{X}$  undergo fission is \_\_\_\_\_  $\times 10^{25}$  MeV.

(Given  $N_A = 6 \times 10^{23}$ )

**Answer (6)**

**Sol.** 120 g of  $^{240}\text{X}$  will have  $\frac{1}{2}$  mole of X

$$\text{Number of atom of X} = \frac{1}{2} \times N_A = 3 \times 10^{23} \text{ atom}$$

$$\begin{aligned} \text{Energy released} &= 3 \times 10^{23} \times 200 \text{ MeV} \\ &= 6 \times 10^{25} \text{ MeV} \end{aligned}$$

30. If a copper wire is stretched to increase its length by 20%. The percentage increase in resistance of the wire is \_\_\_\_\_ %.

**Answer (44)**

**Sol.** let  $\ell_0$  be its initial length and  $A_0$  be initial area.

Considering volume to be conserved

$$\text{Vol.} = \ell_0 A_0 = (1.2\ell_0)A$$

$$A_{\text{final}} = \frac{A_0}{1.2}$$

$$R_{\text{in}} = \frac{\rho \ell_0}{A_0}$$

$$R_{\text{final}} = \frac{\rho 1.2\ell_0}{\frac{A_0}{1.2}} = \frac{\rho \ell_0}{A_0} (1.2)^2$$

$$= R_{\text{in}} (1.44)$$

Hence increase = 44%